

TA14

series



Product Segments

- **Comfort Motion**

TiMOTION's TA14 linear actuator is designed for lift applications like recliners, lifting chairs and movie theater seating. This linear actuator is designed to function as a direct cut system, eliminating the need for a control box, offering a simple and economical alternative. Options for the TA14 include a safety nut and multiple mounting styles for the front attachment.

General Features

Max. load	6,000N (push); 4,000N (pull)
Max. speed at max. load	4.1mm/s
Max. speed at no load	39mm/s
Retracted length	≥ Stroke + 163mm
Certificate	UL962, EMC
Stroke	25~1000mm
Voltage	12/24/36V DC; 24V DC (PTC)
Color	Black, dark grey
Operational temperature range	+5°C~+45°C
at full performance	
For direct-cut system: Can function without control box	

Drawing

Standard Dimensions
(mm)

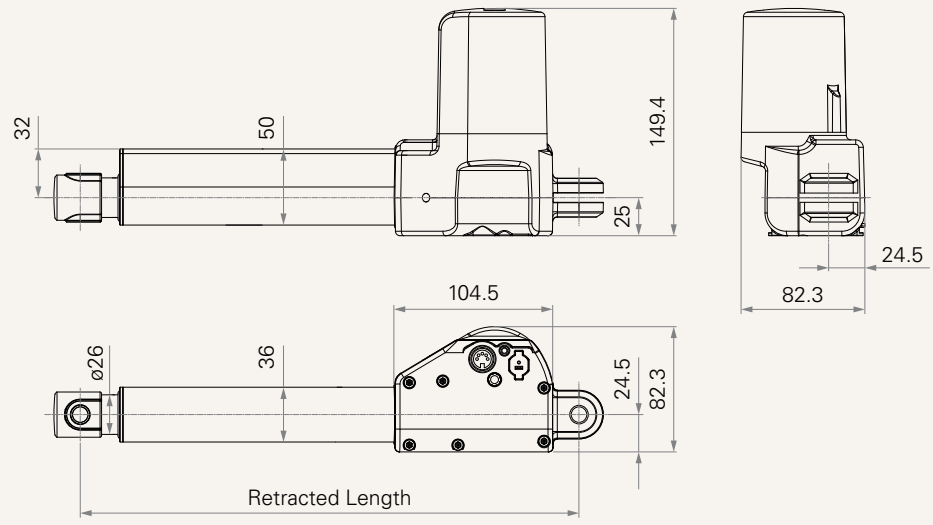

Load and Speed

CODE	Load (N)		Self Locking Force (N)	Typical Current (A)		Typical Speed (mm/s)	
	Push	Pull		No Load 32V DC	With Load 24V DC	No Load 32V DC	With Load 24V DC
Motor Speed (2600RPM, Duty Cycle 10%)							
C	5000	4000	5000	0.8	3.5	8.0	4.1
D	6000	4000	6000	0.8	3.5	6.0	3.1
F	2500	2500	2500	0.8	3.2	15.9	8.3
G	2000	2000	2000	0.8	2.8	21.4	12.1
H	1000	1000	1000	0.8	2.1	32.1	19.1
J	3500	3500	3500	0.8	3.6	11.9	6.0
Motor Speed (3400RPM, Duty Cycle 10%)							
L	6000	4000	6000	1.0	4.2	7.3	4.1
N	2500	2500	2500	1.0	4.1	19.4	11.1
O	2000	2000	2000	1.0	4.0	26.1	14.9
P	1000	1000	1000	1.0	3.0	39.0	23.4
Q	3500	3500	3500	1.0	4.6	14.5	7.9
T	5000	4000	5000	1.0	4.2	9.8	5.4
Motor Speed (3800RPM, Duty Cycle 10%)							
U	5000	4000	5000	1.2	4.7	11.3	6.6
W	2500	2500	2500	1.2	4.6	23.0	13.4
Z	3500	3500	3500	1.2	5.3	16.8	9.8

Note

- 1 Please refer to the approved drawing for the final authentic value.
- 2 This self-locking force level is reached only when a short circuit is applied on the terminals of the motor. All the TiMOTION control boxes have this feature built-in.
- 3 The current & speed in table are tested with 24V DC motor. With a 12V DC motor, the current is approximately twice the current measured in 24V DC. With a 36V DC motor, the current is approximately two-thirds the current measured in 24V DC. Speed will be similar for all the voltages.
- 4 The current & speed in table are tested when the actuator is extending under push load.
- 5 The current & speed in table and diagram are tested with TiMOTION control boxes, and there will be around 10% tolerance depending on different models of the control box. (Under no load condition, the voltage is around 32V DC. At rated load, the voltage output will be around 24V DC)
- 6 Standard stroke: Min. \geq 25mm, Max. please refer to below table.

CODE	Load (N)	Max Stroke (mm)
D, L	= 6000	600
Others	< 6000	1000

Performance Data (24V DC Motor)

Motor Speed (2600RPM, Duty Cycle 10%)

Speed vs. Load

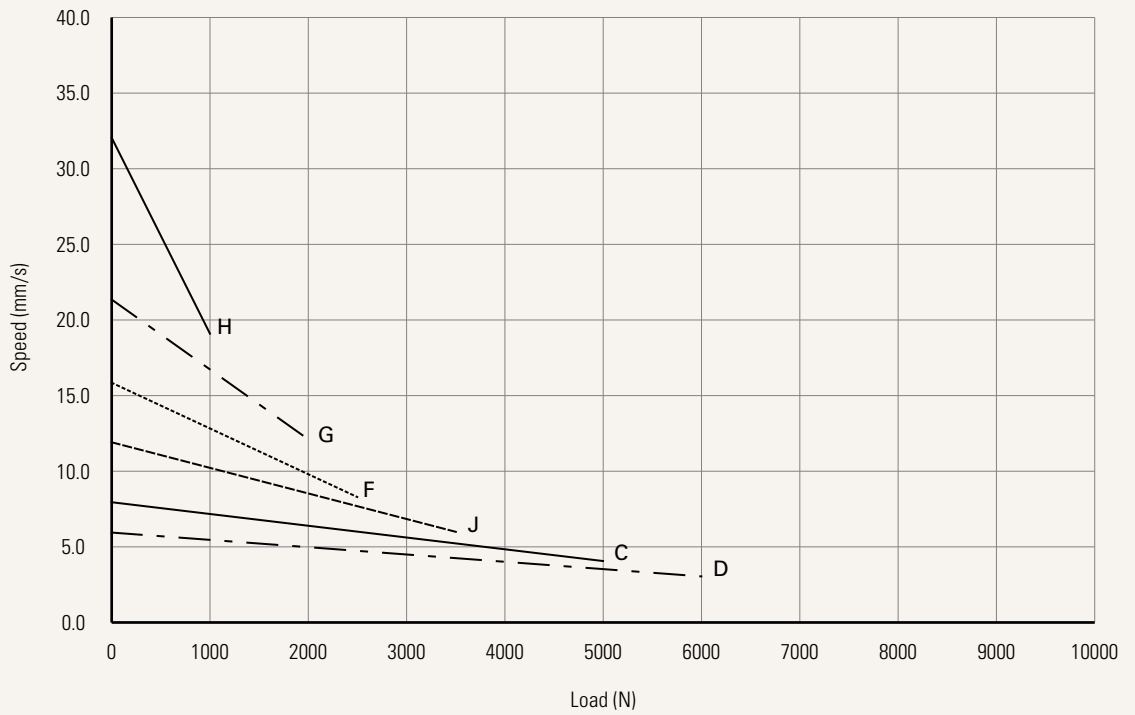

Current vs. Load

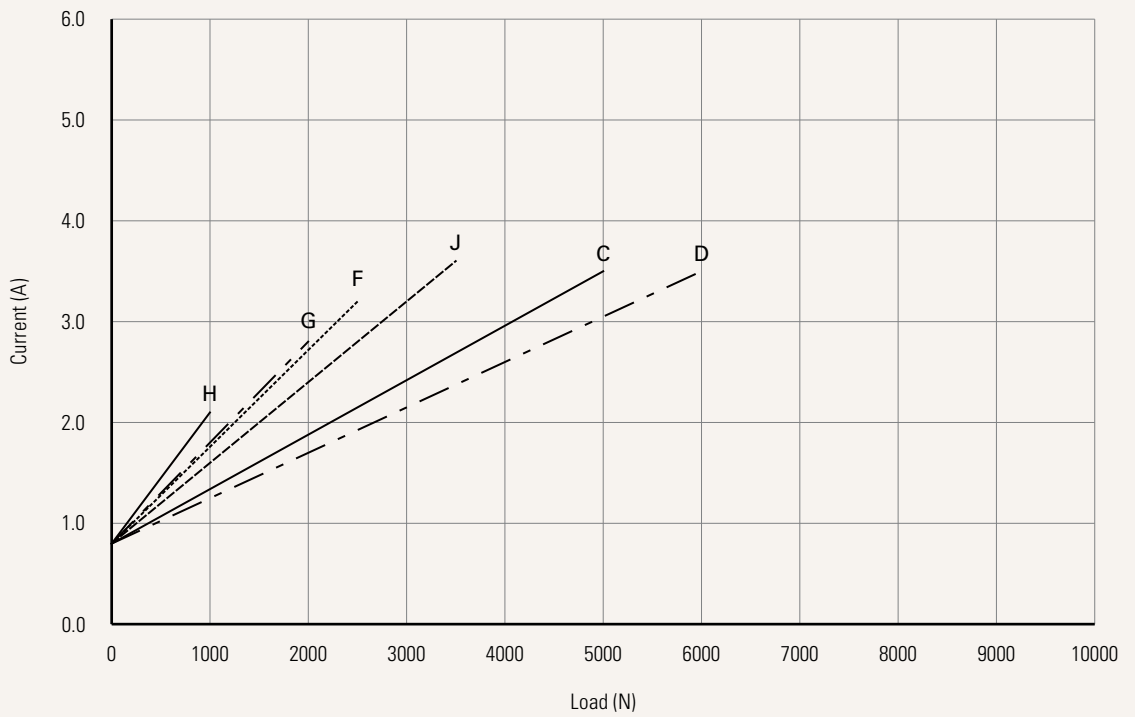

Performance Data (24V DC Motor)

Motor Speed (3400RPM, Duty Cycle 10%)

Speed vs. Load

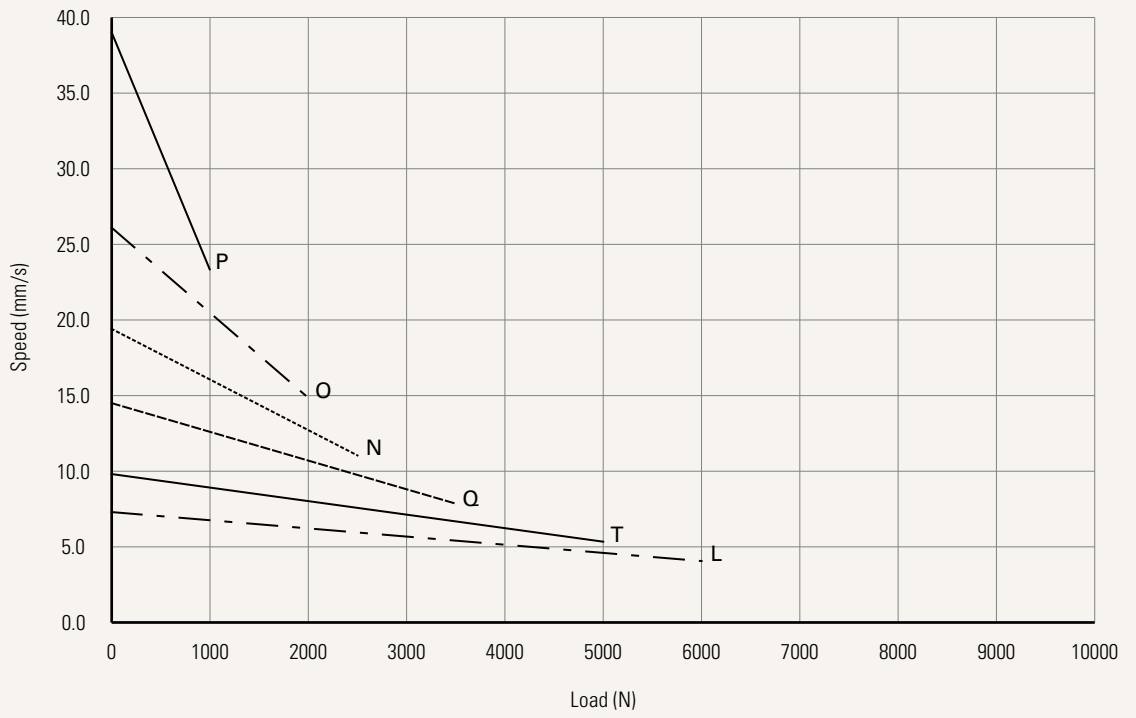

Current vs. Load

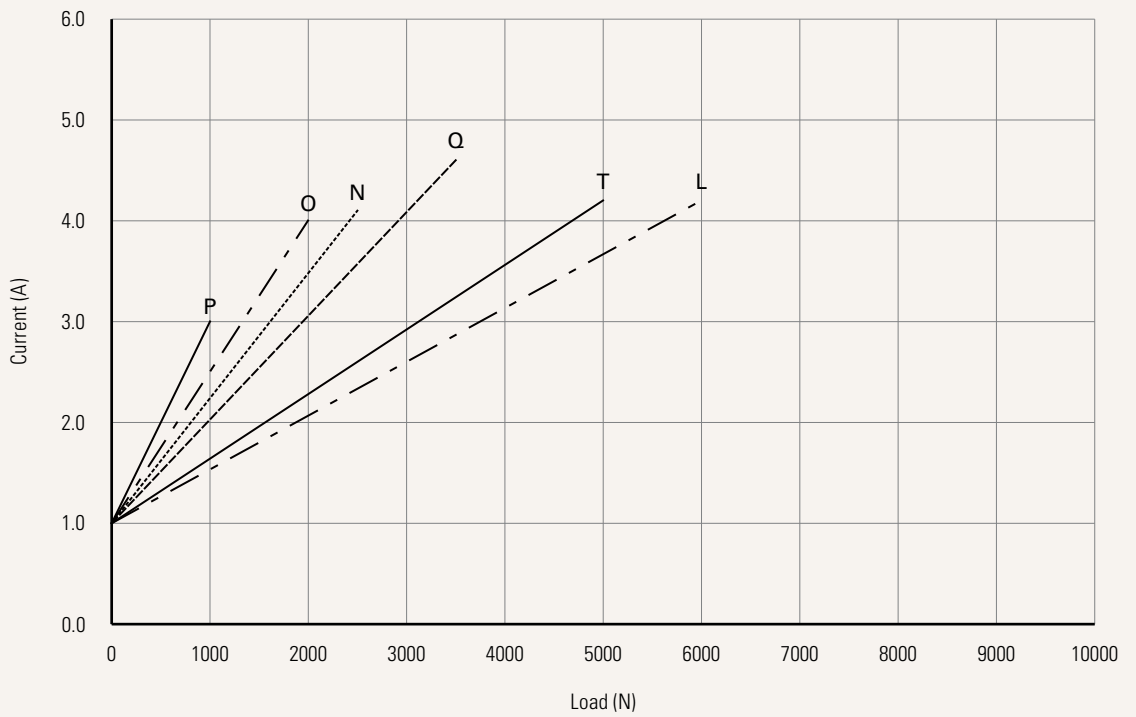

Performance Data (24V DC Motor)

Motor Speed (3800RPM, Duty Cycle 10%)

Speed vs. Load

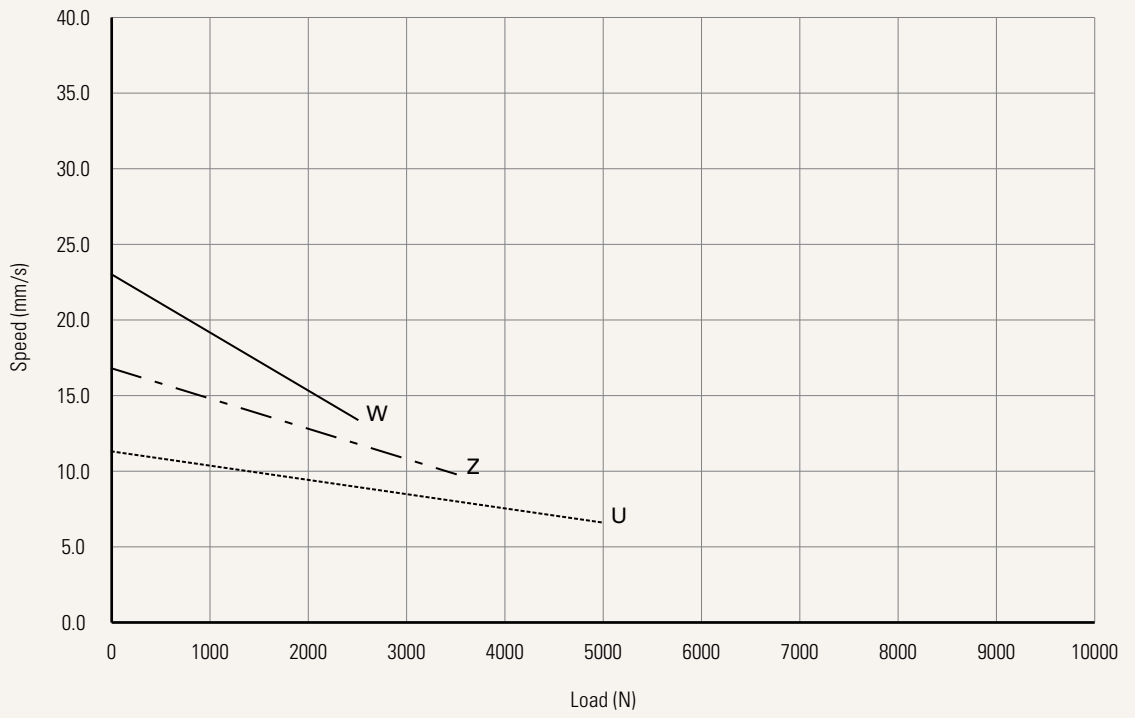

Current vs. Load

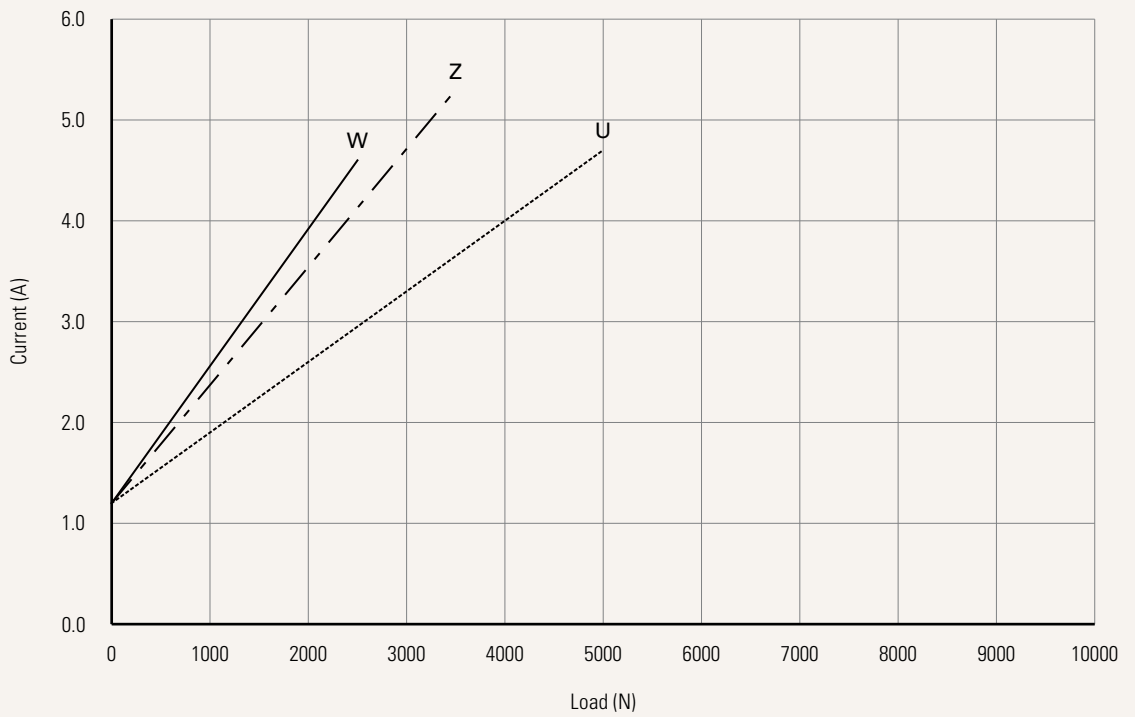

Voltage	1 = 12V DC	2 = 24V DC	3 = 36V DC	5 = 24V DC, PTC
Load and Speed	See page 3			
Stroke (mm)	See page 3			
Retracted Length (mm)	See page 8			
Rear Attachment (mm)	1 = Plastic, U clevis, slot 6.1, depth 17.0, hole 10.2			
	See page 9			
Front Attachment (mm)	1 = Punched hole on inner tube + plastic cap, without slot, hole 10.2, plastic bush	6 = Punched hole on inner tube, without slot, hole 12.2		
	2 = Punched hole on inner tube + plastic cap, without slot, hole 12.2	7 = Aluminum casting, U clevis, slot 6.2, depth 17.0, hole 10.2		
	3 = Plastic, U clevis, slot 8.2, depth 20.2, hole 10.2, for load push < 4000N & pull < 2500N	8 = Aluminum casting, U clevis, slot 6.2, depth 17.0, hole 12.2		
	4 = Plastic, U clevis, slot 8.2, depth 20.2, hole 12.2, for load push < 4000N & pull < 2500N	9 = Aluminum casting, U clevis, slot 6.2, depth 17.0, hole 10.2, T-bush		
	5 = Punched hole on inner tube, without slot, hole 10.2, plastic bush			
Color (Gear box)	1 = Black	5 = Dark grey		
Special Functions for Spindle Sub-Assembly	0 = Without	1 = Safety nut	2 = Standard push only	3 = Safety nut and standard push only
Connector	1 = Direct cut operation with single actuator	P = Molex 8P, 90° plug, without anti-clip		
	2 = Direct cut operation with 2 actuators	Q = Molex 6P, 90°plug (40511-123)		
Output Signals	0 = Without			
Brake	0 = Without	4 = Spindle brake (4.5N)	M = Motor brake	
Load Type	T = Push	P = Pull	1 = Push + Pull, mainly push	2 = Push + Pull, mainly pull
IP Rating	1 = Without			

Retracted Length (mm)

1. Calculate $A+B+C = Y$
2. Retracted length needs to $\geq \text{Stroke}+Y$

A.	
Front Attach.	
1, 2, 5, 6	+163
3, 4	+185
7, 8, 9	+175

B.		
Stroke (mm)	Load (N)	
	< 6000	= 6000
25~150	-	-
151~200	-	-
201~250	-	+5
251~300	-	+10
301~350	+5	+15
351~400	+10	+20
401~450	+15	+25
451~500	+20	+30
501~550	+25	+35
551~600	+30	+40
601~650	+35	x
651~700	+40	x
701~750	+45	x
751~800	+50	x
801~850	+55	x
851~900	+60	x
901~950	+65	x
951~1000	+70	x

C.		
Front Attach.	Spindle Function	
	0, 1	2, 3
1, 2, 5, 6	-	+5
3, 4	-	-
7, 8, 9	-	-

Rear Attachment (mm)

1 = Plastic, U clevis, slot 6.1, depth 17.0, hole 10.2

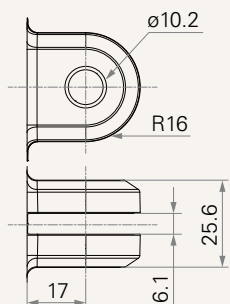

Front Attachment (mm)

1 = Punched hole on inner tube + plastic cap, without slot, hole 10.2, plastic bush

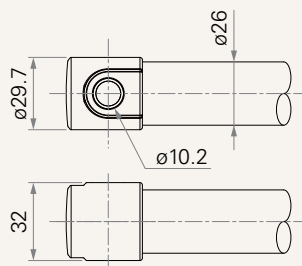

2 = Punched hole on inner tube + plastic cap, without slot, hole 12.2

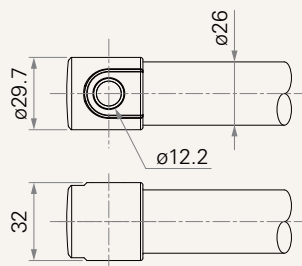

3 = Plastic, U clevis, slot 8.2, depth 20.2, hole 10.2, for load push < 4000N & pull < 2500N

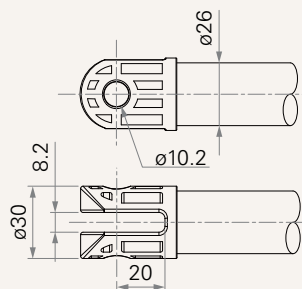

4 = Plastic, U clevis, slot 8.2, depth 20.2, hole 12.2, for load push < 4000N & pull < 2500N

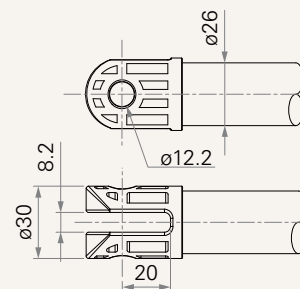

5 = Punched hole on inner tube, without slot, hole 10.2, plastic bush

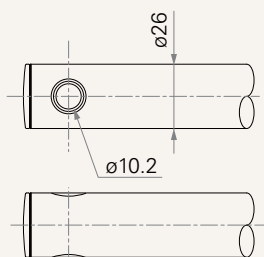

6 = Punched hole on inner tube, without slot, hole 12.2

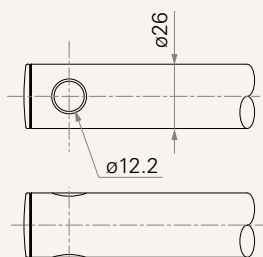

7 = Aluminum casting, U clevis, slot 6.2, depth 17.0, hole 10.2

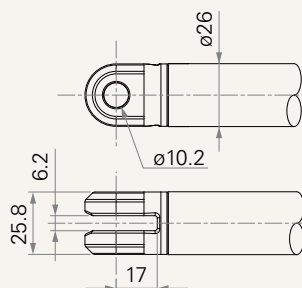

8 = Aluminum casting, U clevis, slot 6.2, depth 17.0, hole 12.2

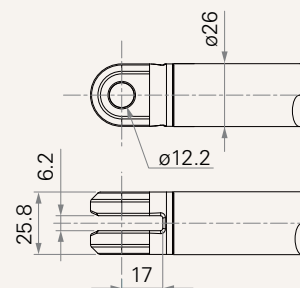

9 = Aluminum casting, U clevis, slot 6.2, depth 17.0, hole 10.2, T-bush

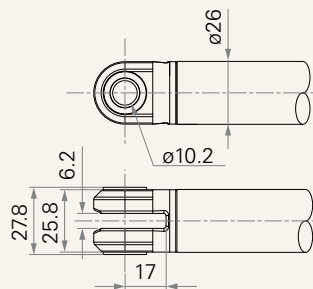

Connector

1 = Direct cut operation with single actuator

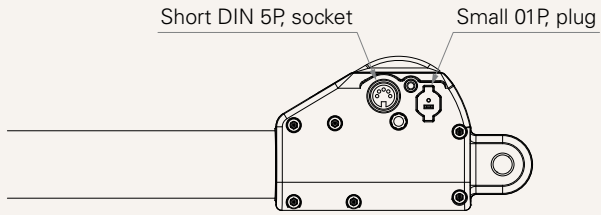

2 = Direct cut operation with 2 actuators

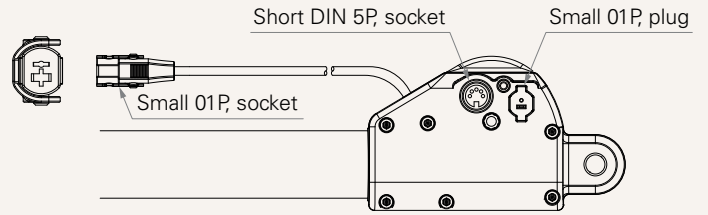

P = Molex 8P, 90° plug, without anti-clip

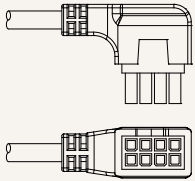

Q = Molex 6P, 90° plug (40511-123)

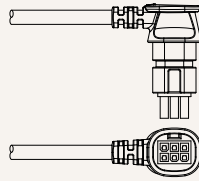

Terms of Use

The user is responsible for determining the suitability of TiMOTION products for a specific application. TiMOTION products are subject to change without prior notice.