

TA49

series



Product Segments

• Care Motion

Designed for medical applications with zero backlash in mind, the TA49 is suitable for operating (surgical) table applications. It can lift up to 6000N rated up to IP66W. Additionally, it's an excellent option for treatment tables, procedure chairs, and stretcher bed applications.

General Features

Max. load	6,000N (push); 2,000N (pull)
Max. speed at max. load	4.4mm/s
Max. speed at no load	14.7mm/s
Retracted length	≥ Stroke + 157mm
IP rating	IP66W
Stroke	25~450mm
Output Signals	Hall sensors
Voltage	24V DC; 24V DC (PTC)
Color	Grey
Operational temperature range at full performance	+5°C~+45°C
A zero backlash design actuator	

Drawing

Standard Dimensions
(mm)

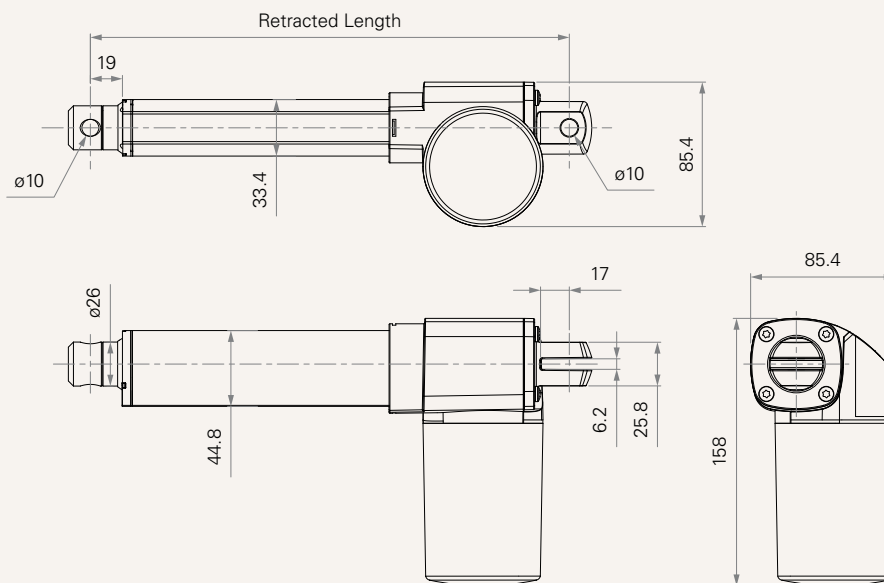

Load and Speed

CODE	Load (N)		Self Locking Force (N)	Typical Current (A)		Typical Speed (mm/s)	
	Push	Pull		No Load 32V DC	With Load 24V DC	No Load 32V DC	With Load 24V DC
Motor Speed (3800RPM, Duty Cycle 10%)							
G	6000	2000	6000	1.5	4.4	6.5	3.8
N	3000	2000	3000	1.5	4.0	12.3	7.5
Motor Speed (4500RPM, Duty Cycle 10%)							
M	6000	2000	6000	1.7	5.0	7.5	4.4
P	3000	2000	3000	2.0	4.4	14.7	9.0

Note

- 1 Please refer to the approved drawing for the final authentic value.
- 2 This self-locking force level is reached only when a short circuit is applied on the terminals of the motor. All the TiMOTION control boxes have this feature built-in.
- 3 The current & speed in table are tested with 24V DC motor. With a 12V DC motor, the current is approximately twice the current measured in 24V DC; speed will be similar for both voltages.
- 4 The current & speed in table are tested when the actuator is extending under push load.
- 5 The current & speed in table and diagram are tested with TiMOTION control boxes, and there will be around 10% tolerance depending on different models of the control box. (Under no load condition, the voltage is around 32V DC. At rated load, the voltage output will be around 24V DC)
- 6 Standard stroke: Min. ≥ 25 mm, Max. please refer to below table.

CODE	Load (N)	Max Stroke (mm)
G, N, M, P	≤ 6000	450

Performance Data (24V DC Motor)

Motor Speed (3800RPM, Duty Cycle 10%)

Speed vs. Load

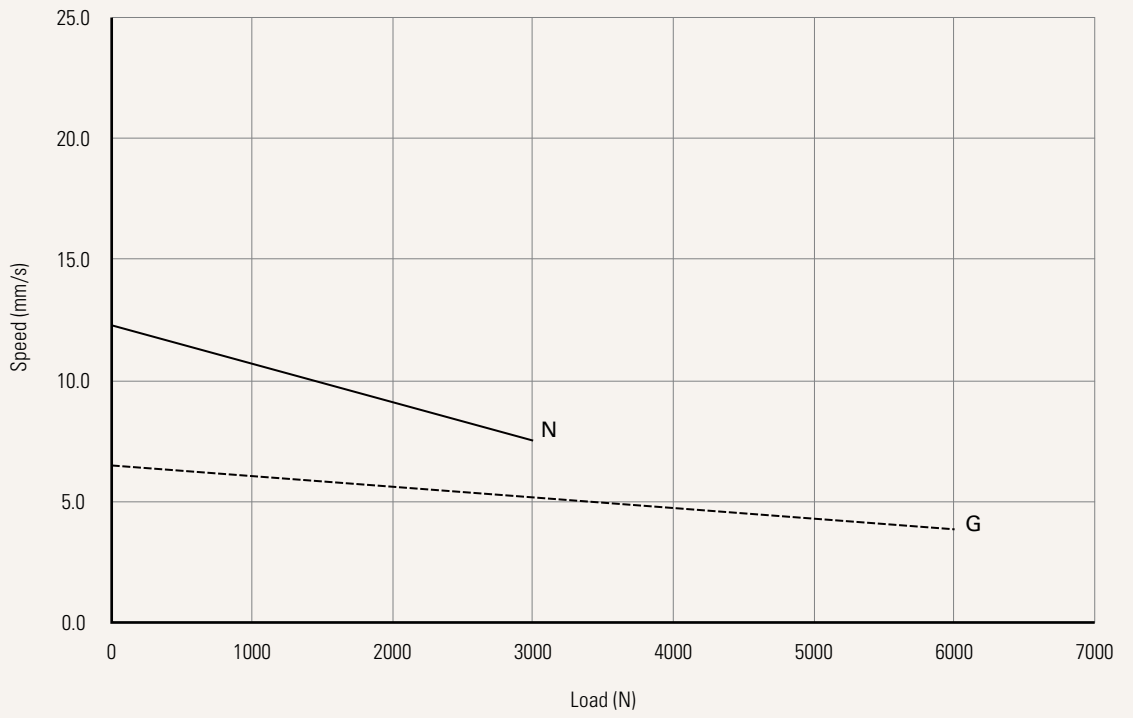

Current vs. Load

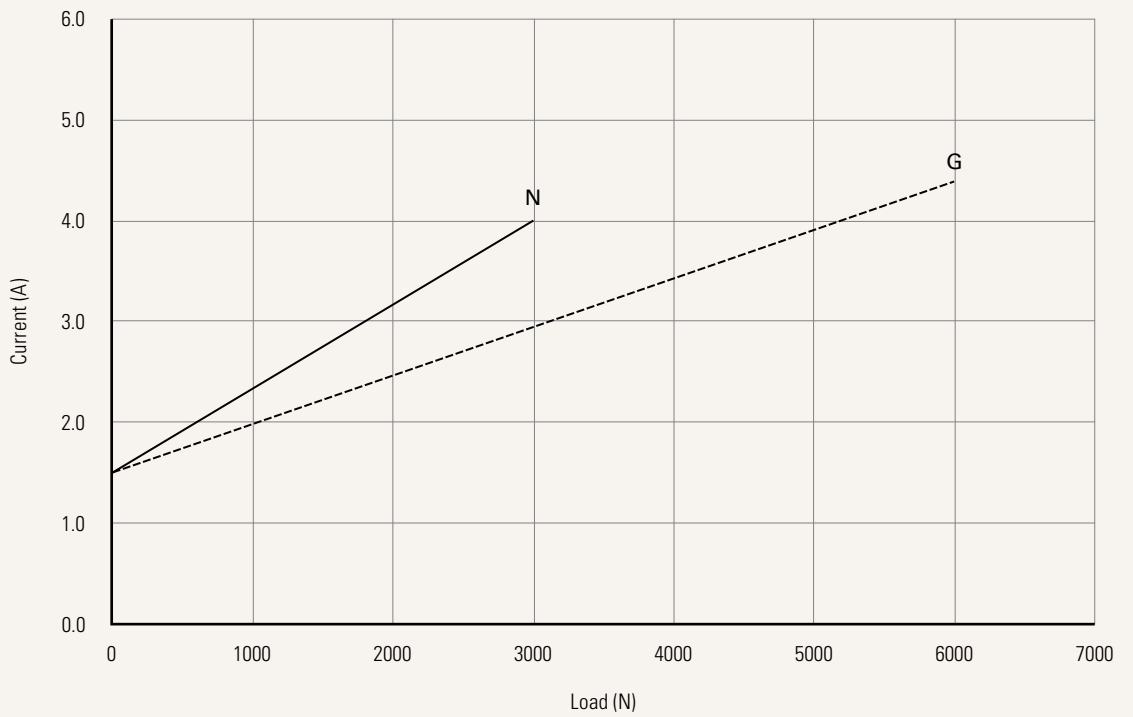

Performance Data (24V DC Motor)

Motor Speed (4500RPM, Duty Cycle 10%)

Speed vs. Load

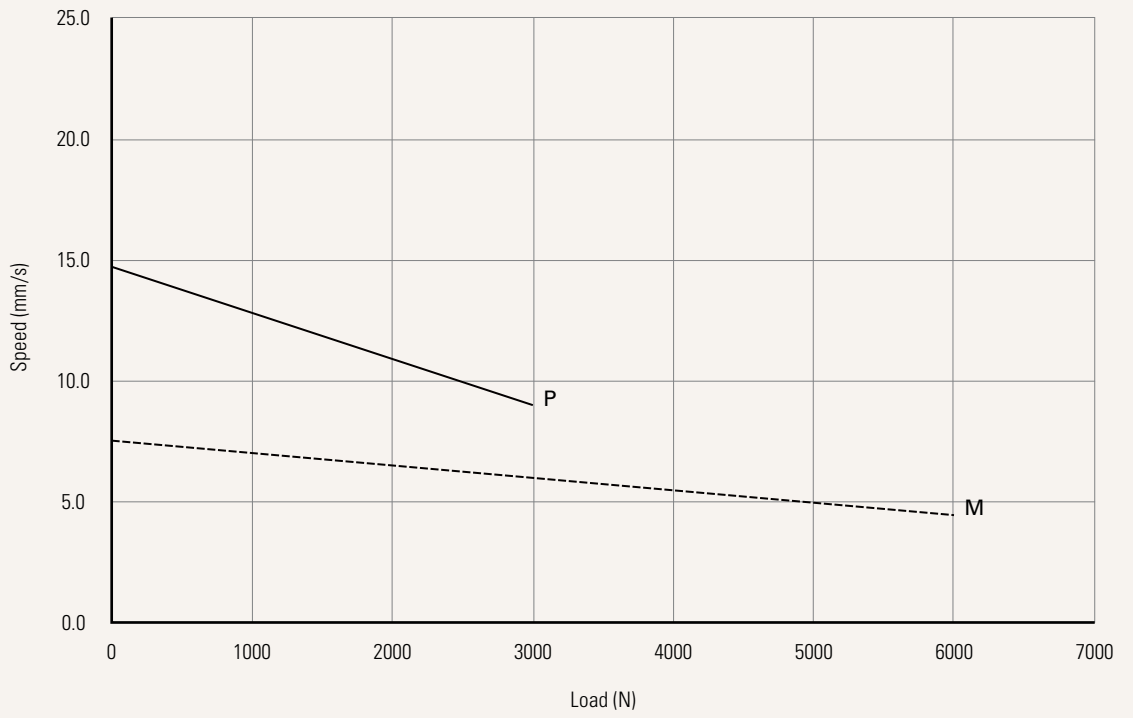

Current vs. Load

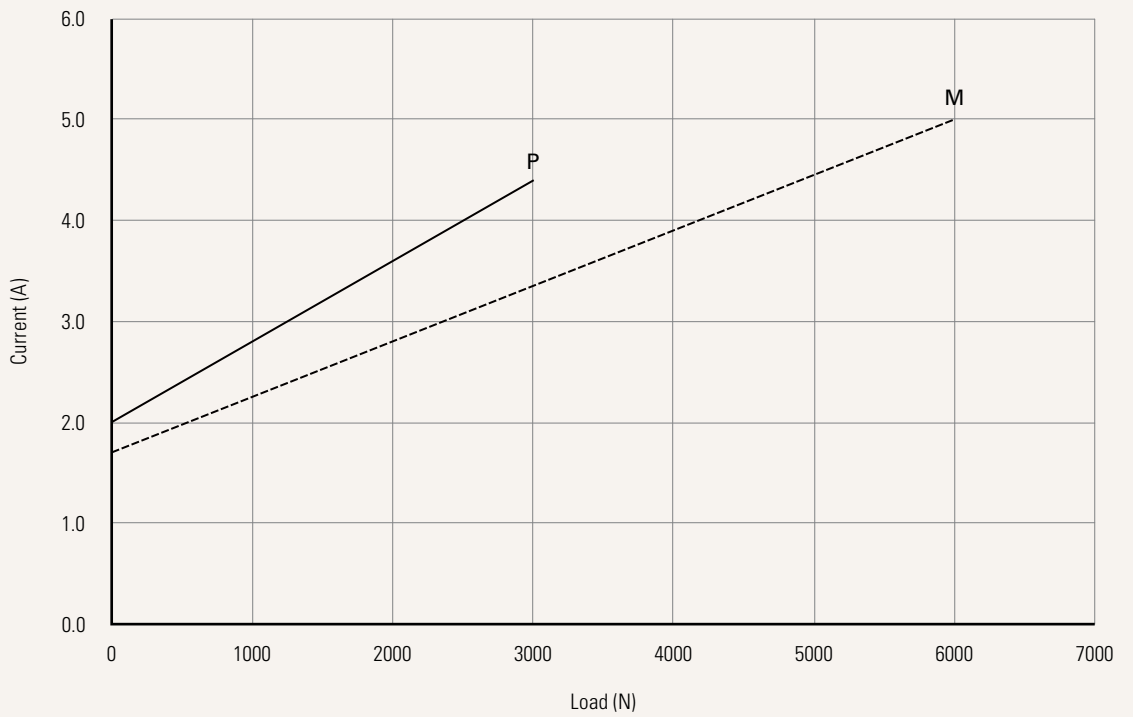

Voltage	2 = 24V DC	5 = 24V DC, PTC		
Load and Speed	See page 2			
Stroke (mm)	See page 2			
Retracted Length (mm)	See page 6			
Rear Attachment (mm)	1 = Aluminum casting, U clevis, width 6.2, depth 17.0, hole 10	P = Threated end with M12, 25-30 deep		
	See page 7			
Front Attachment (mm)	1 = Aluminum CNC, without slot, hole 10	P = Threated end with M12, 25-30 deep		
	See page 7			
Direction of Rear Attachment (Counterclockwise)	1 = 0°	3 = 90°		
	See page 7			
Color	2 = Pantone 428C			
IP Rating	1 = Without	2 = IP54	3 = IP66	5 = IP66W
Special Functions for Spindle Sub-Assembly	0 = Without (Standard)	1 = Safety nut		
Functions for Limit Switches	1 = Two switches at full retracted / extended positions to cut current	4 = Two switches at full retracted / extended positions to send signal + third one in between to send signal		
	2 = Two switches at full retracted / extended positions to cut current + third one in between to send signal	5 = Two switches at full retracted / extended positions to send signal (Operate with control box: TC1, TC8, TC10, TC14; compatible with hall sensors)		
	3 = Two switches at full retracted / extended positions to send signal			
	See page 8			
Output Signal	0 = Without	2 = Hall sensor * 2		
Connector	1 = DIN 6P, 90° plug	4 = Big 01P, plug	E = Molex 8P, plug	G = Audio plug
	2 = Tinned leads	C = Y cable (direct cut, water proof, anti-pull)	F = DIN 6P, 180° plug	Q = Molex 6P, 90° plug
	See page 8			
Cable Length (mm)	0 = Straight, 100	3 = Straight, 1000	6 = Straight, 2000	B-H = For direct cut system. See page 8
	1 = Straight, 500	4 = Straight, 1250	7 = Curly, 200	
	2 = Straight, 750	5 = Straight, 1500	8 = Curly, 400	

Retracted Length (mm)

1. Calculate $A+B+C = Y$
2. Retracted length needs to \geq Stroke+Y

A.

Front Attachment	
1	+157
P	+189

B.

Stroke (mm)	Load (N)
	≤ 6000
25~150	-
151~200	-
201~250	+5
251~300	+10
301~350	+15
351~400	+20
401~450	+25

Note

- 1 For stroke over 450mm, please contact our engineers.

C.

Special Functions for Spindle Sub-Assembly	Load (N)
	≤ 6000
0	-
1	-

Rear Attachment (mm)

1 = Aluminum casting, U clevis, width 6.2, depth 17.0, hole 10

P = Threated end with M12, 25-30 deep

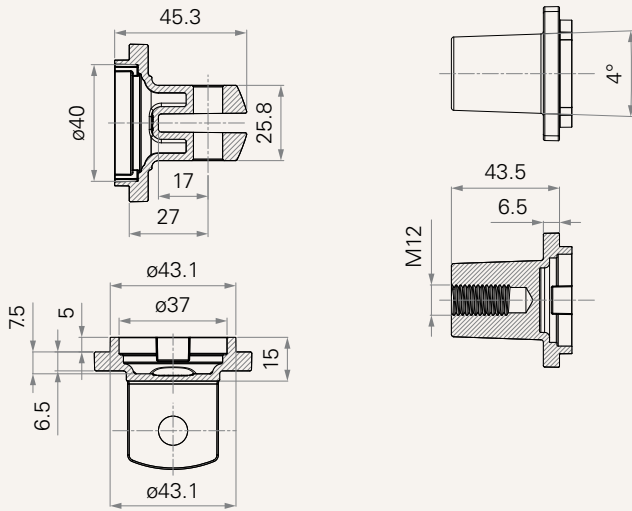

Front Attachment (mm)

1 = Aluminum CNC, without slot, hole 10

P = Threated end with M12, 25-30 deep

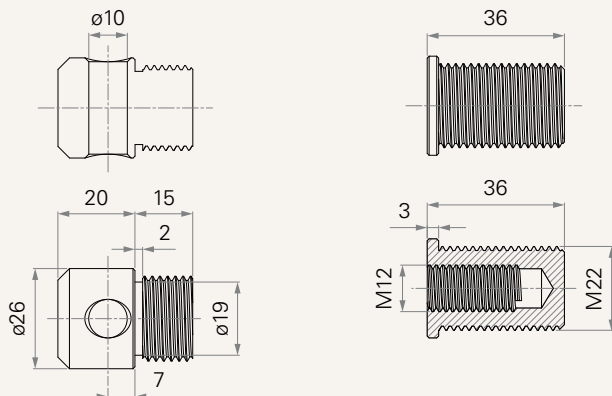

Direction of Rear Attachment (Counterclockwise)

1 = 0°

3 = 90°

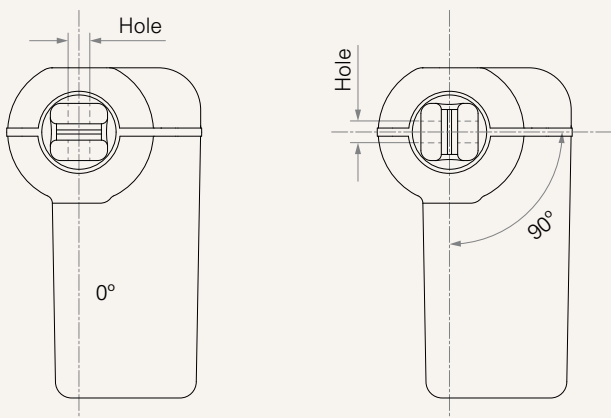

Functions for Limit Switches

Wire Definitions

CODE	Pin					
	● 1 (Green)	● 2 (Red)	○ 3 (White)	● 4 (Black)	● 5 (Yellow)	● 6 (Blue)
1	extend (VDC+)	N/A	N/A	N/A	retract (VDC+)	N/A
2	extend (VDC+)	N/A	middle switch pin B	middle switch pin A	retract (VDC+)	N/A
3	extend (VDC+)	common	upper limit switch	N/A	retract (VDC+)	lower limit switch
4	extend (VDC+)	common	upper limit switch	medium limit switch	retract (VDC+)	lower limit switch
5	extend (VDC+)	N/A	upper limit switch	common	retract (VDC+)	lower limit switch

Connector

1 = DIN 6P, 90° plug

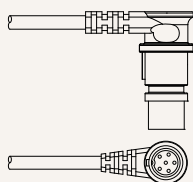

2 = Tinned leads



4 = Big 01P, plug

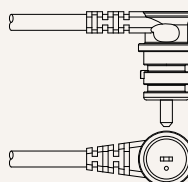

C = Y cable (direct cut, water proof, anti-pull)

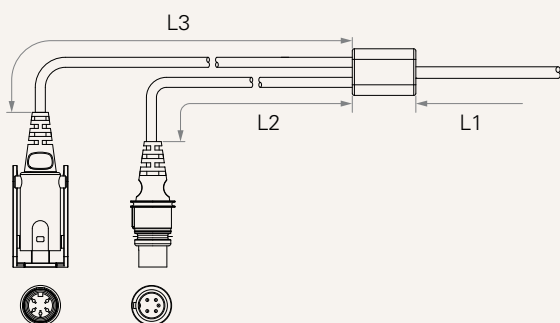

Cable Length for Direct Cut System (mm)

CODE	L1	L2	L3
B	100	100	100
C	100	1000	400
D	100	2700	500
E	1000	100	100
F	100	600	1000
G	1500	1000	1000
H	100	100	1200

E = Molex 8P, plug

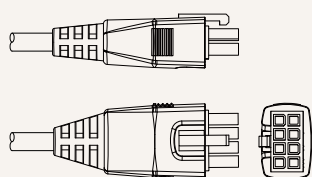

F = DIN 6P, 180° plug



G = Audio plug



Q = Molex 6P, 90° plug

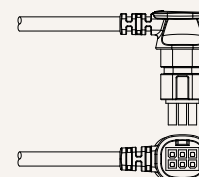

Terms of Use

The user is responsible for determining the suitability of TiMOTION products for a specific application. TiMOTION products are subject to change without prior notice.