

Efficiency of time and space in production

LCMR200

Linear Conveyor Module



Maximum Payload **30kg**

- Optimal for transferring middle weight in-vehicle components.
- The price stays the same even when major applications are doubled.

Yamaha's answer to the Next Generation of
Production Line design

Adding productivity to transportation process

Convert transfer process into “value-added” assembly process



- Reduction of Tact Time in transportation
- Flexibility in line design
- Easy maintenance
- Low operation cost
- Improved Productivity
- Reduces line design time
- Space saving design
- Durability

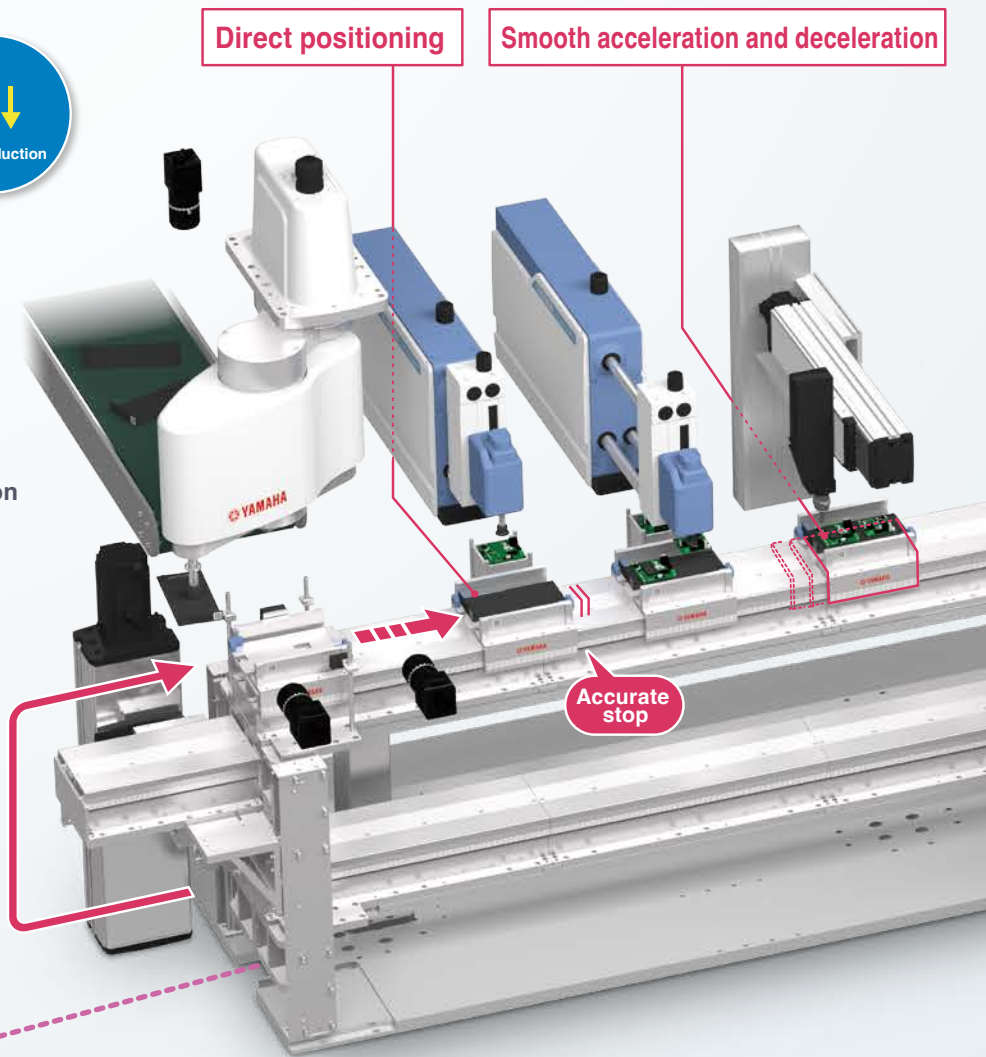

YHX controller

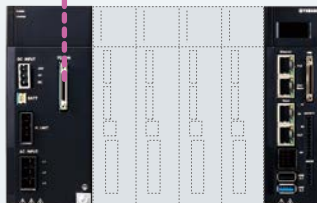

Controllable line length Max. **25.5 m** *

Number of simultaneous controllable sliders Max. **64 units** *

* It may differ depending on the system configuration.

LCMR200

Linear Conveyor Module

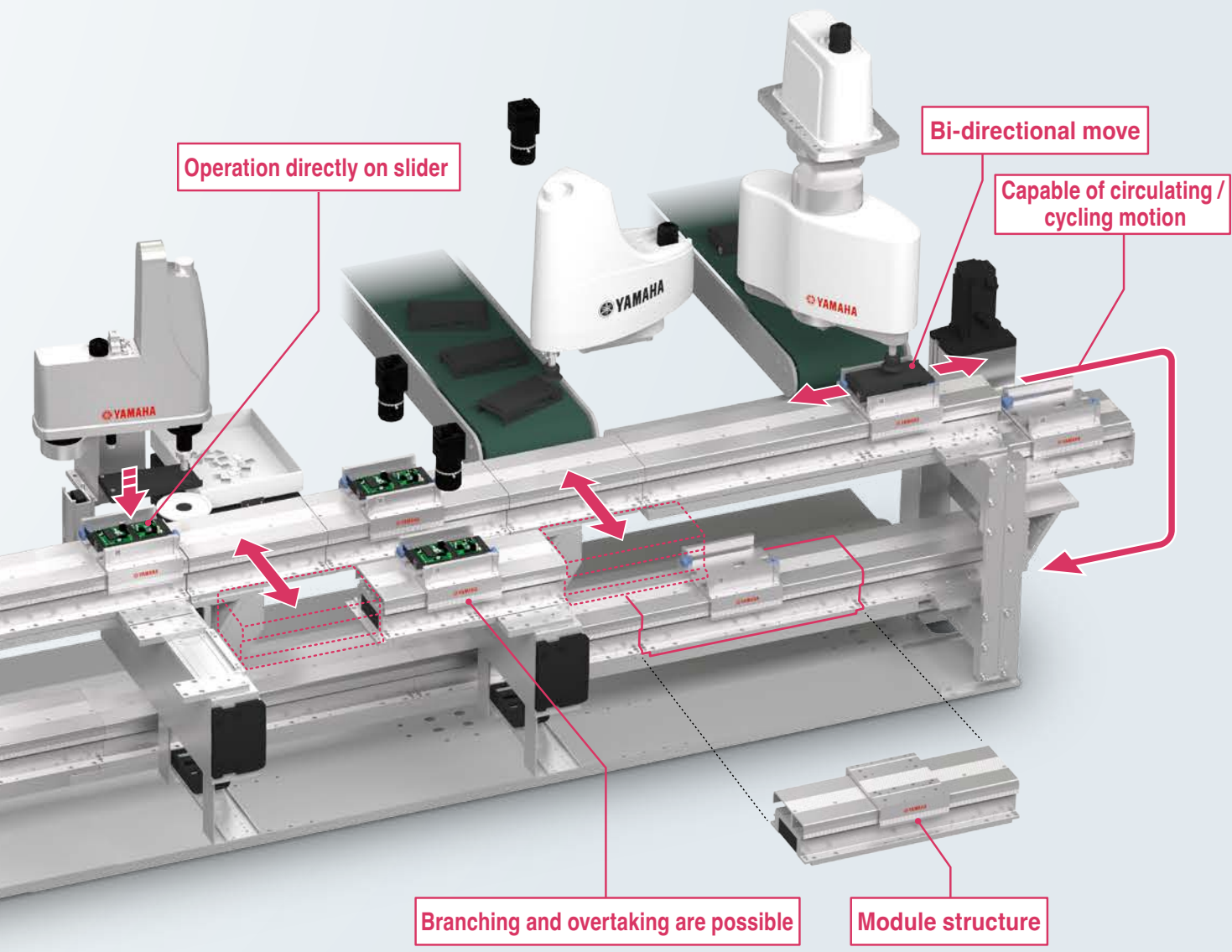

Able to perform narrow pitch and high speed transport.

Individual ID recognition.

Complete absolute position system. No origin process needed.

Built-in driver and reduced wiring.

Advanced linear conveyor module with high speed transport.

From ordinary “passive flow” to By converting conveyor flow into

LCMR200 vs Conventional Conveyor System

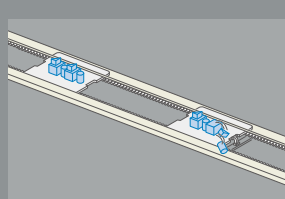

Conventional type conveyors

- Mechanical stoppers or sensors are required at each stop position.
- Complicated control due to various conveyor components.
- Stopper adjustments are required each time the stop position is changed.
- Fixed productivity rate.
- Various adjustments required

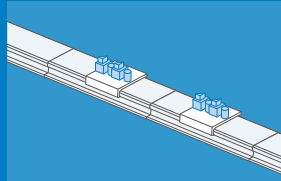

New LCMR200

- Direct driving of the slider.
- Stop positions are controlled with position data in program.
- No mechanical stoppers or external sensors required.
- Maximum speed of 2.5 m/sec for better transfer time.
- Adjustable transfer speed for total line flow coordination.
- Actual task times can be easily monitored.

Speed control	△ Same speed required on entire conveyor	○ Able to specify the speed and acceleration speed individually.
Operation control	× One (fixed) direction	○ Bi-directional and distance can be set individually for each carriage
Travel / Stops	× Physical impact at mechanical stop	○ Smooth servo-controlled acceleration, deceleration, and incremental move
Number of system components	× Stopper or sensor required at each stop position	○ No mechanical components required for stop position
Accuracy	△ Additional support is required to increase accuracy	○ Mechanical tolerance between sliders (between total sliders) +/- 30 μm
Rigidity	△ Additional support is required to ensure rigidity	○ Assembly work can be performed directly on carriage supported by high-rigidity guides
Line flow changes	× Requires stopper adjustments at each line flow change	○ Simple modification of line layout by modular design. Stop position can be changed in program
Footprint	△ Certain space is required	○ Space saving design

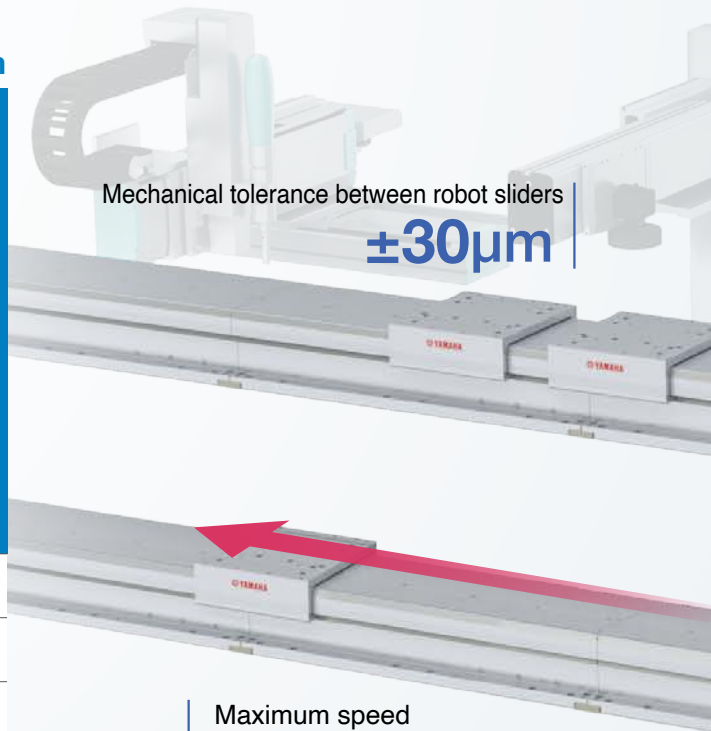

Maximum speed
2500mm/sec*

*Speed will be reduced to 1,000 mm/sec if dynamic load is over 10 kg.

Reduce transport time. <Comparison between LCMR200 and a conventional conveyor>

Finished

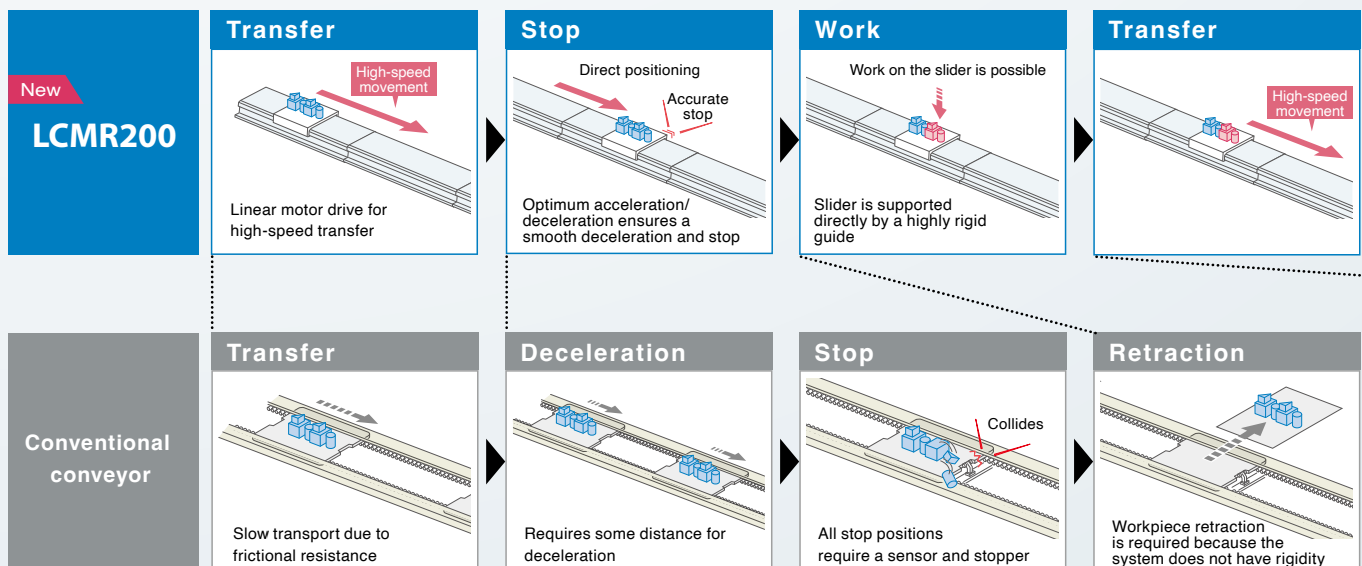

“active position transport”.

an active production process it improves profitability.

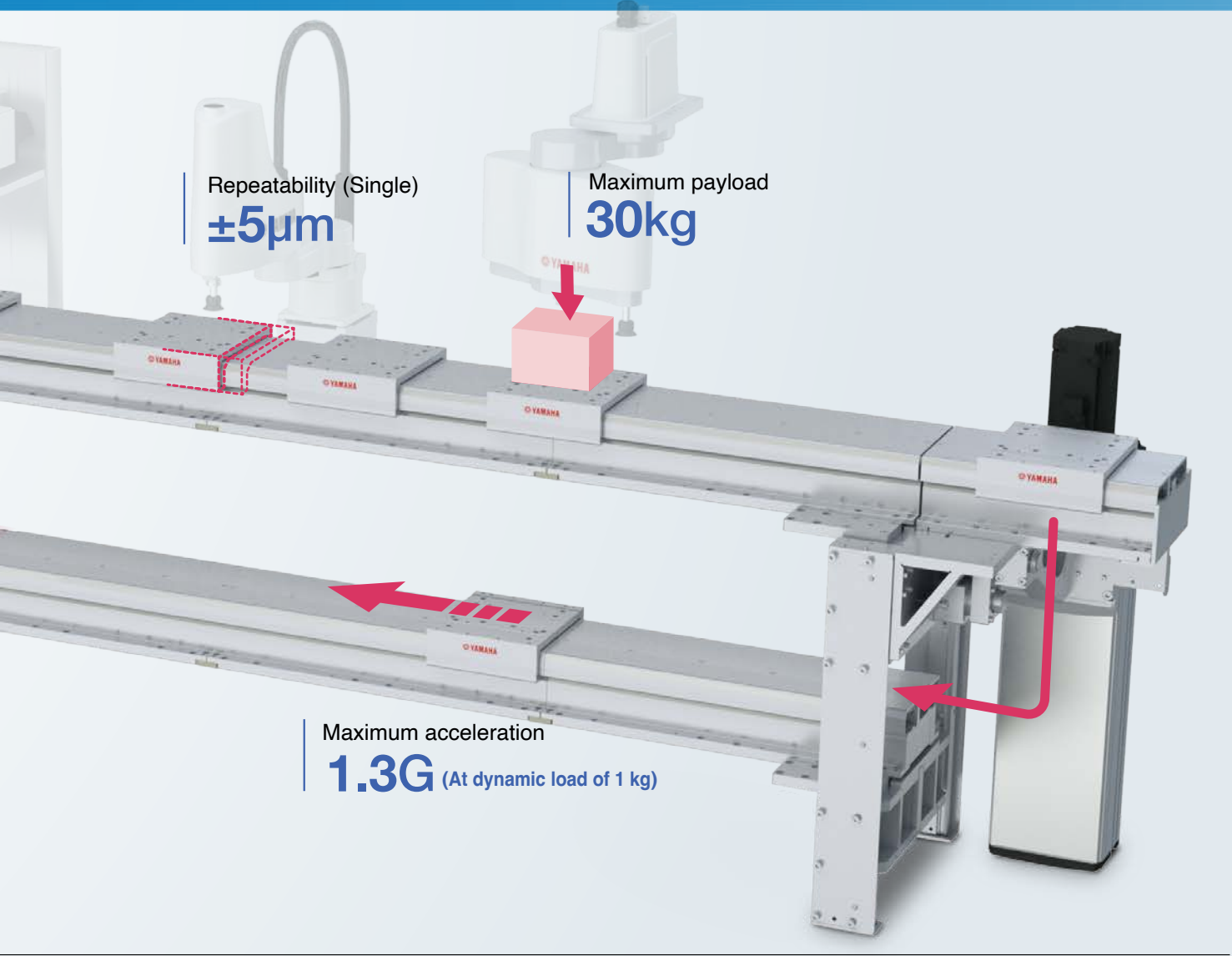

Transfer time is reduced from **6** to **3** seconds.

50%
reduction
in tact time

Finished

Increased by approx.
80%

Increased yield

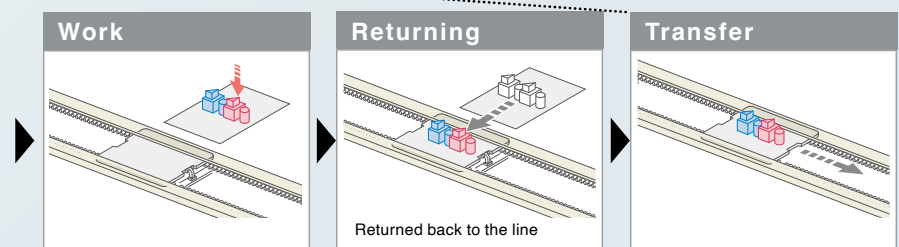
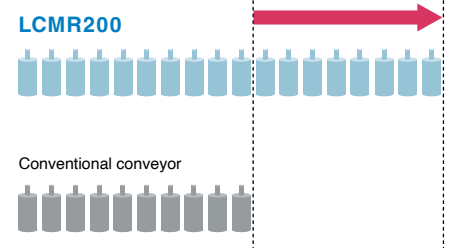

Note. May vary depending on conditions

Subject to user's operation setup.



Easy modular connection with Connecting Plate and Connecting Unit

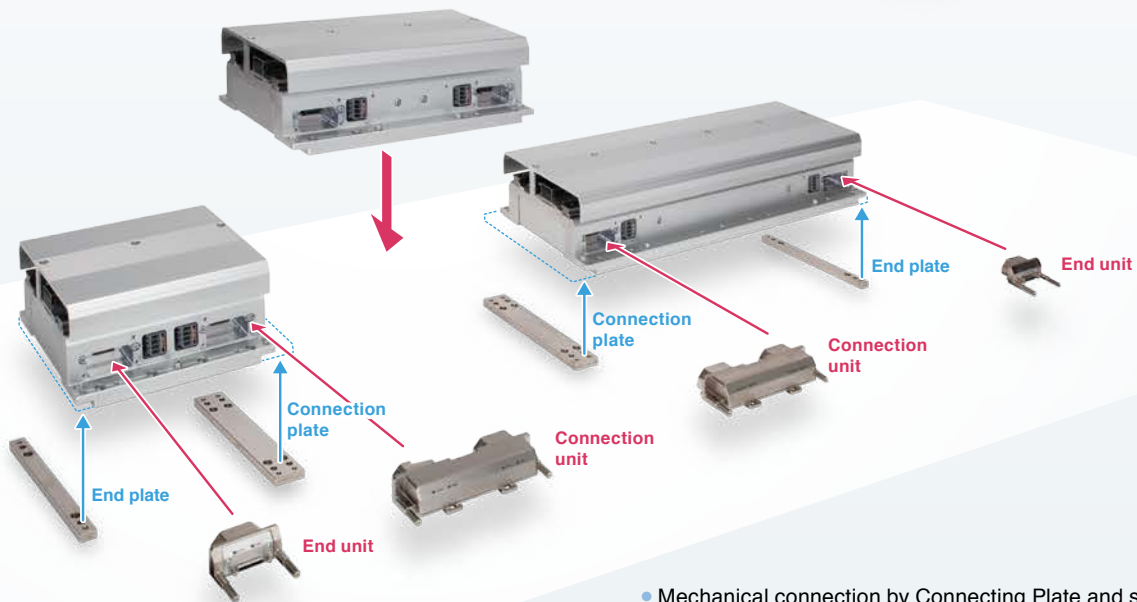

- Mechanical connection by Connecting Plate and signal communicating by Connecting Unit. Simple yet, secured connecting method of modular system.

Top enclosure design for protection.

- Top enclosure was designed to protect internal mechanism from any fallen object during line setup process.

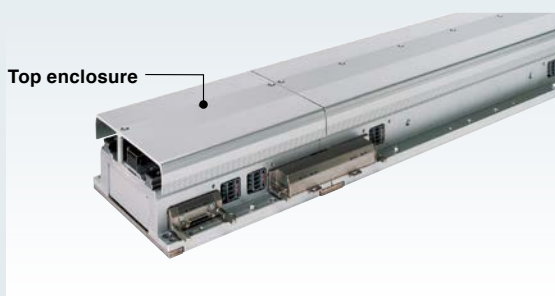

Low profile structure

- By adopting a newly developed linear motor, the module height is approx. 30 % down compared to LCM100. The space under the frame can be effectively utilized.

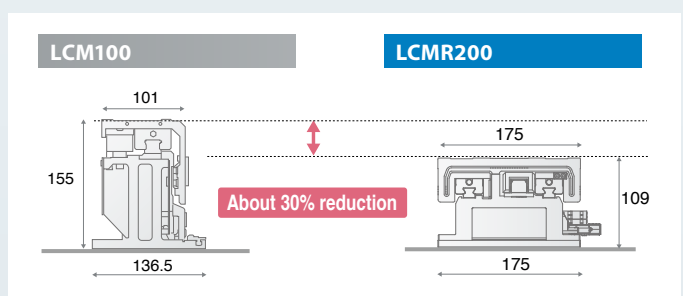

Superior performance that improves the transfer environment.



Saves space through proximity installation of forward and returning modules

<Cable extraction direction can be selected **Front** **Rear** >

- Since the cable extraction direction of a module can be selected, the degree of freedom in electrical wiring is improved when installed on the equipment. In particular, when the cable extraction direction is reversed on the forward and returning modules in the horizontal circulation layout, the circulation pitch* can be made close to the shortest level of 200 mm. This can shorten the cycle time and reduce the installation space during circulation.

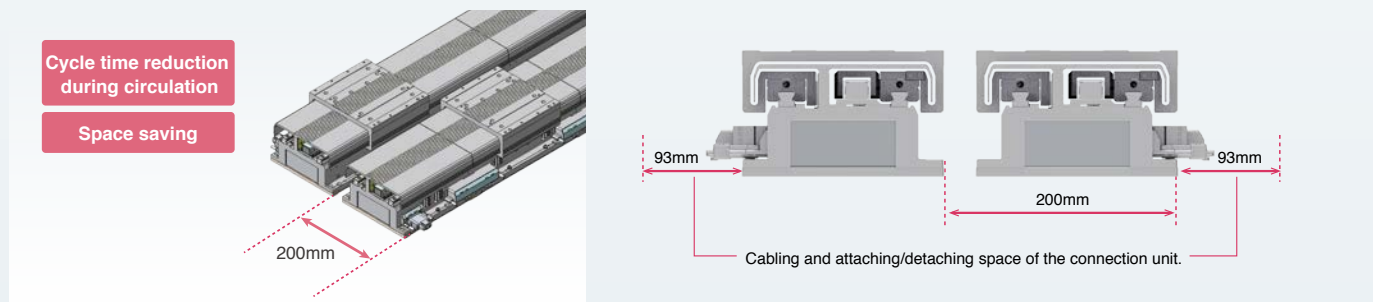

* For details about the circulation pitch, see page 31.

- LED indicators that show the module status can be visually recognized from both the front and rear of the module.

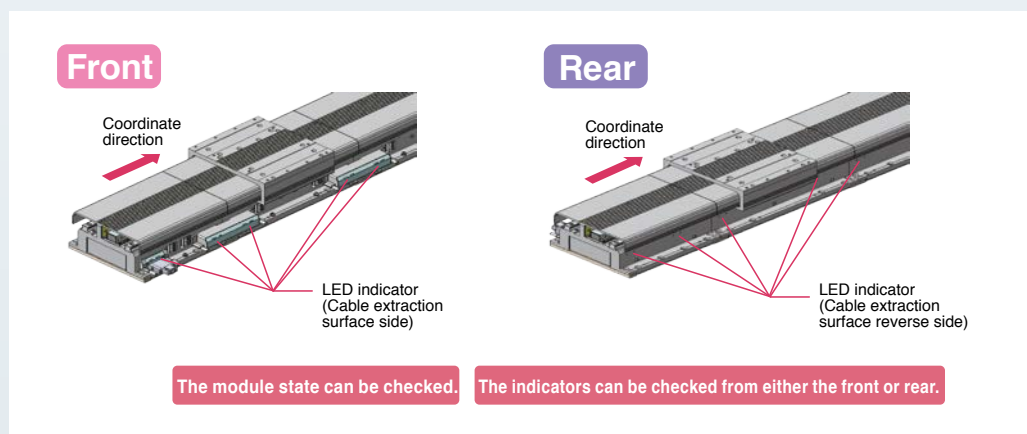



All the sliders can be operated / programmed independently.

- Speed and acceleration can be programmed by each move. All carriages can be controlled individually.

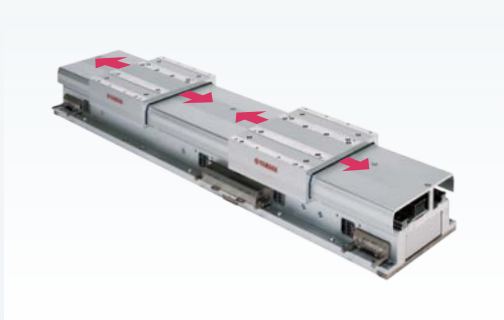

High acceleration rate

- High speed motion between an extremely short distance is possible even in a high density process or pitch feed.

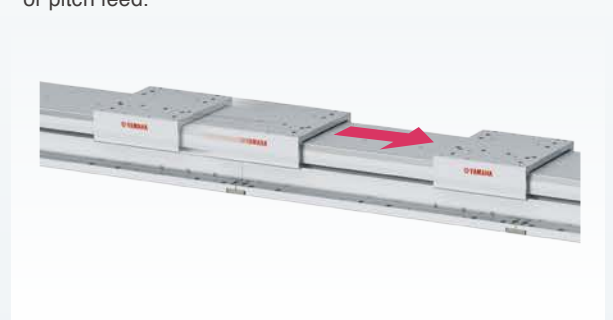

Mechanical tolerance between sliders +/-30 μm (Dowel hole standard)

- Due to its machined accuracy, each carriage has its own tolerance at one stopping point, however, LCMR200 can limit the slide machine difference to +/-30 μm, and is suitable for high precision process. As RFID, etc. is not necessary, cost reduction is possible.

Built-in driver saves electrical wiring

- Motor driver is incorporated inside module and entire LCMR200 is controlled by YHX controller through YQLink cable. It also contributes to space saving inside the control panel.

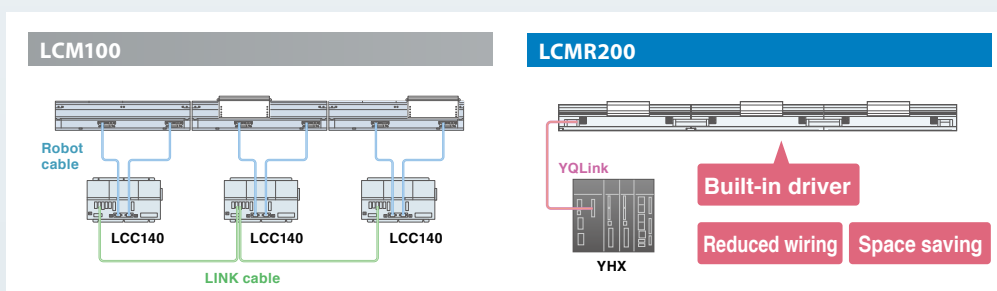

Transfer process is robotized to provide both the high quality and productivity improvement.

No origin process needed

- Newly developed high-precision full-range absolute server eliminates the need for return-to-origin. The operation can be started and stopped easily, so there is no time loss even when starting or restarting.

Recognize slider's individual IDs

- All sliders can be identified when the power is applied.

Return-to-origin is not needed since the ID and current position of each slider are recognized when the power is turned ON.

Optimal for traceability management

- As the slider ID is associated with the workpiece or jig, the specific product, the jig ID used, and component ID can be identified and traced.
- As the current position of the slider can be output during movement among processes, the slider position can be understood in real time.

★ When a product failure occurs.

Product serial No.	Jig	Work A	Work B	Work C					
#1001	0:02	#0690	0:03	A9442	0:04	B9641	0:07	C3425	0:10
#1002	0:05	#4574	0:06	A0916	0:07	B7459	0:10	C6063	0:13
#1003	0:08	#2857	0:09	A1640	0:10	B3823	0:13	C8644	0:16
#1004	0:11	#7826	0:12	A5204	0:13	B3957	0:16	C3622	0:19
#1005	0:14	#0690	0:15	A4396	0:16	B6822	0:19	C1896	0:22
#1006	0:17	#4574	0:18	A0634	0:19	B3337	0:22	C6729	0:25
#1007	0:20	#2857	0:21	A0593	0:22	B4375	0:25	C8895	0:28
#1008	0:23	#7826	0:24	A7217	0:25	B0881	0:28	C9871	0:31
#1009	0:26	#0690	0:27	A3595	0:28	B7295	0:31	C8738	0:34

The work completion time of each process is also recorded.
The serial number of the jig or workpiece is associated with the slider ID.

Versatile and value added transport between work process.

Improve cycle time and reduce line floor space.

Increase productivity and cost performance.

Process sharing

Direct drive

Slider backward travel



- Carriage is bi-directional and one work station can perform more than one task. Saving total line cost and floor space.
- High speed bi-directional move and simultaneous independent operation of multiple carriages.

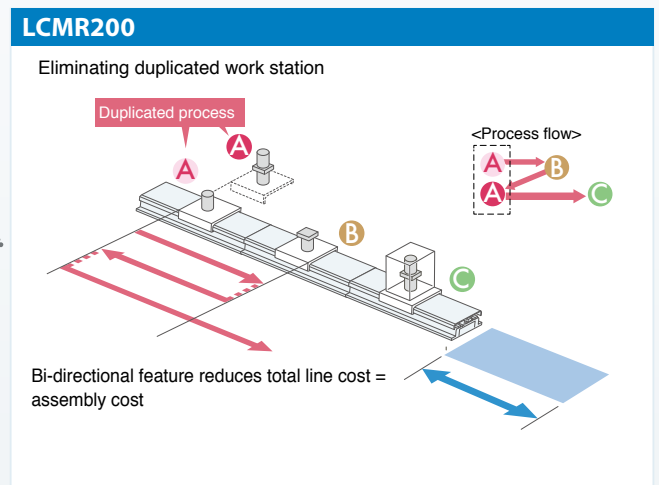
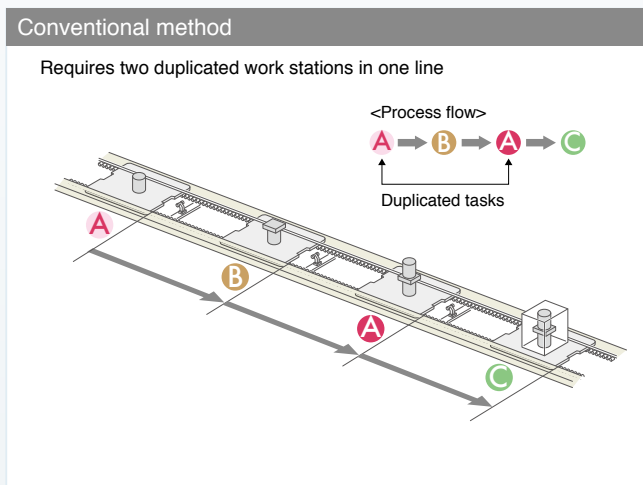

Variable speed control between work stations.

Direct drive

Narrow pitch operation



- Servo controlled direct drive eliminates mechanical stoppers and position sensors.
- Simple position setting by entering point data in a program.
- Flexibility in setup for production lot change
- Saving flow time by narrow pitch incremental move and high speed move.

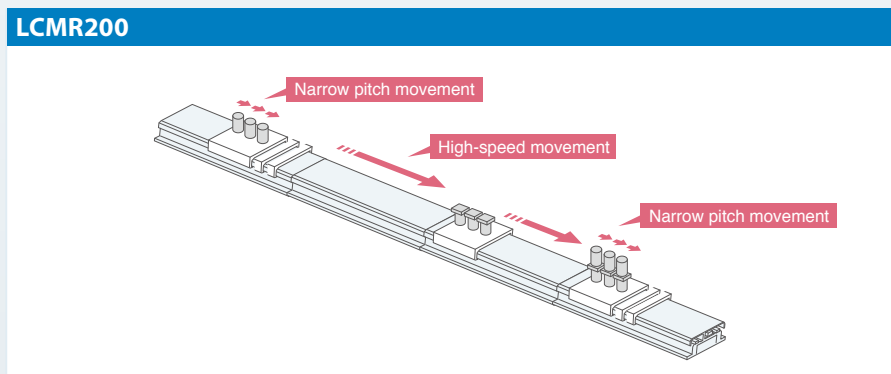

Easily serviceability = Easy troubleshooting

- Covered structure of module keeps internal mechanism free from foreign objects
- The environment-resistant magnetic sensor is resilient to contamination.
- Easy positioning with no precision setting.
- Non-contact motor and linear scale design eliminates mechanical wearing
- Low particle generation (only mechanical contact is guide rail)
- Standardized components reduce spare parts SKU.
- Parts can be replaced easily.
- Operation can be restored just by replacing the slider or linear module, and the manufacturing line down time can be kept to a minimum.





Assembly can be done while parts are on the conveyor

Highly rigid guide



- The highly rigid guide enables assembly and processing on the transport line.
- No need to reposition parts to/from the conveyor. Floor line space is reduced substantially.

Conventional method

Parts need to be moved to the work bench

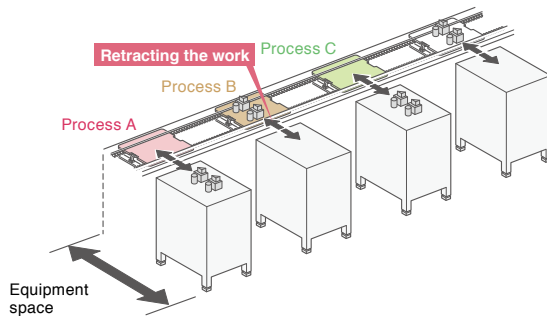

LCMR200

Assembly work is done while parts are on the conveyor

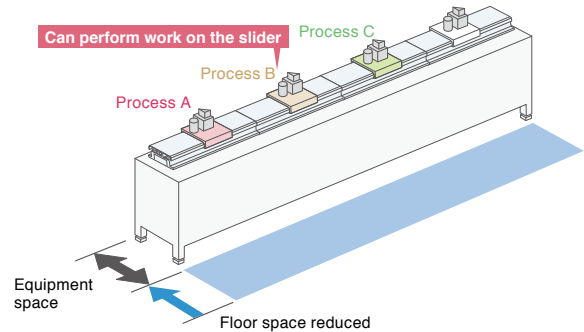

Concentrated control by the YHX controller

- Including the operation environment, all sliders and single-axis robots on the transfer process can be controlled.

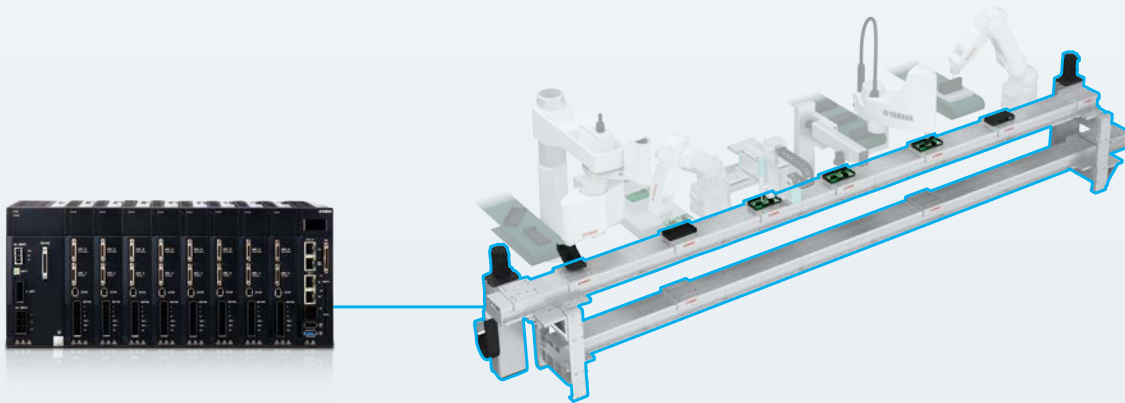

Simple control with the standard profile

- According to the commands from the host PLC, it adopts a simple control method that operates the sliders and single-axis robots as positioners <See Page 20 for detail>.

Features of YHX standard profile

- Eliminates writing ladder logic codes.
- Adding operation through a pendant.
- Perform simple direct value operation and specific point-to-point move.
- Servo ON of any slider individually.
- Obtain alarm information through the host PLC.

Sleek and simple configuration. Simplified line design process with flexibility and efficiency by modular concept.

All carriages and peripheral linear robots can be controlled by PLC through one YHX controller.

Example of a layout using the circulation unit

Horizontal circulation example

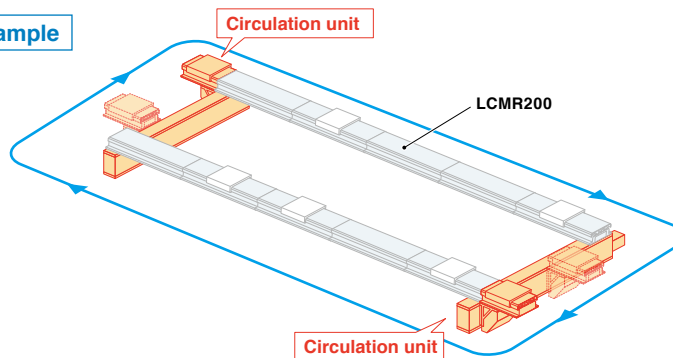

Vertical circulation example

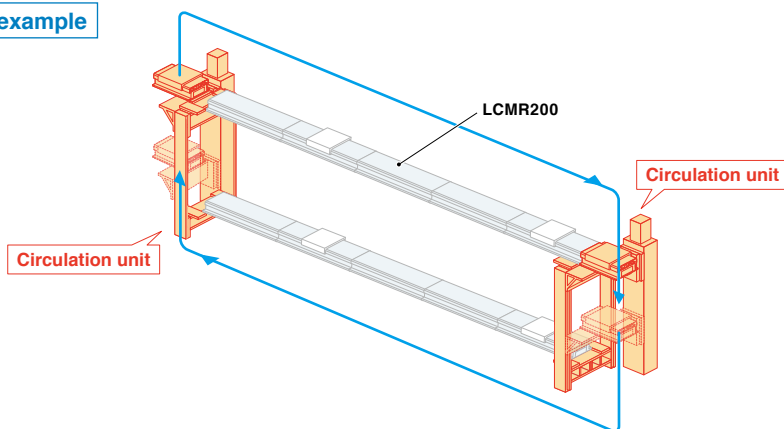

Example of a layout using the traversing unit

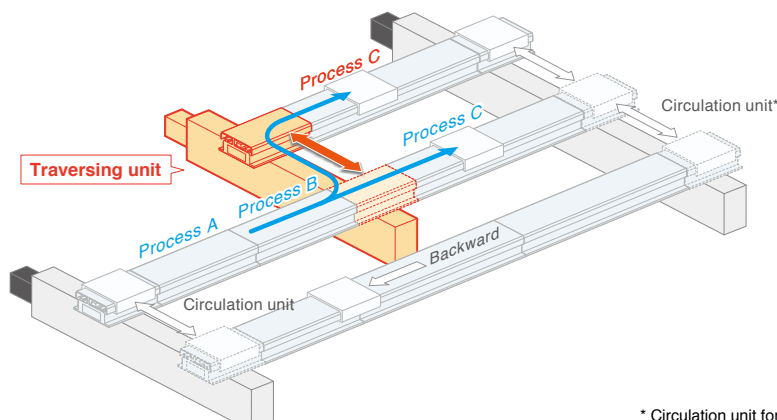

* Circulation unit for 3-row line is a special order product.

Circulation unit / Traversing unit features

POINT ① Measures against 'deviation' is necessary to maintain the accuracy and are taken thoroughly.

Maintaining the accuracy is very important for transfer sections, but is not easy since a "deviation" may occur. Use of YAMAHA genuine circulation units makes it possible to eliminate "deviations" and maintain the accuracy.

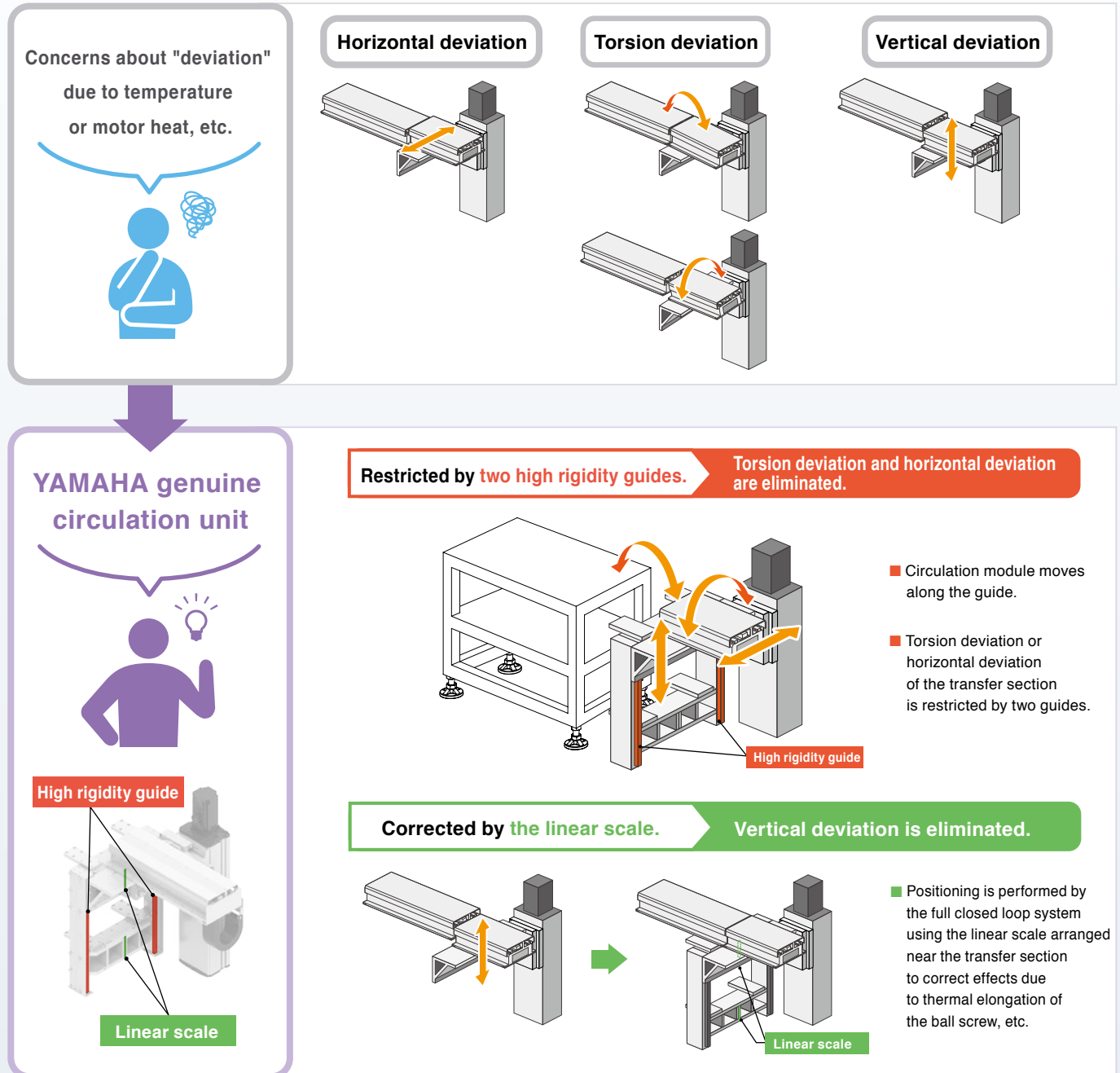

POINT ② Easy adjustment

The adjustment has been performed before shipment from the factory. After the product has arrived, the adjustment is completed in a short time by simply attaching the module to the equipment based on the end plate and performing the teaching.

The module on the main line side is positioned by the end plate.

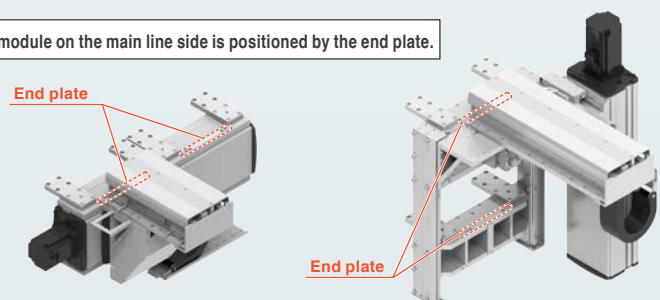

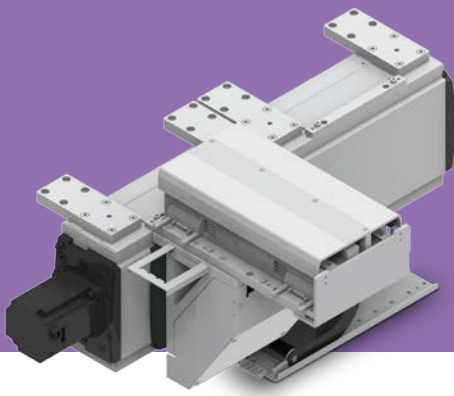

Circulation unit

Circulation units are available as standard. Because the circulation units are manufacturer's standard products, the stable operation of the production line is achieved without worrying about module "deviation". Furthermore, you can also save time and effort in design.

YAMAHA genuine circulation units achieve the stable operation of the production line.

YAMAHA genuine circulation unit

Horizontal circulation unit

JGX16-H

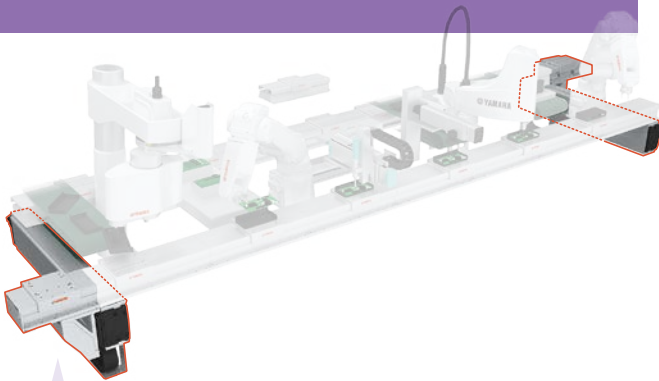

Vertical circulation unit

JGX16-V

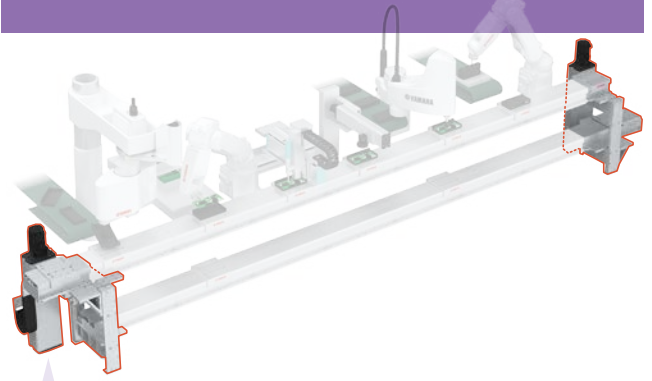

End plate
(For positioning of the module
on the main line side)

Circulation
installation plate

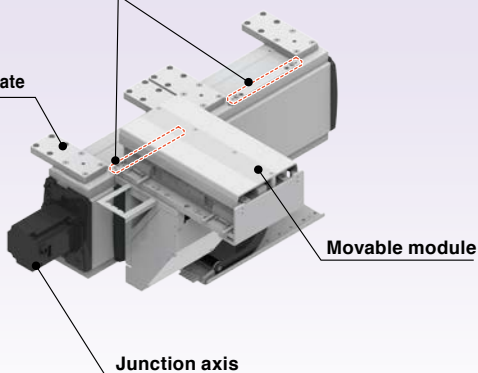

Junction axis

Movable module

Circulation
installation plate

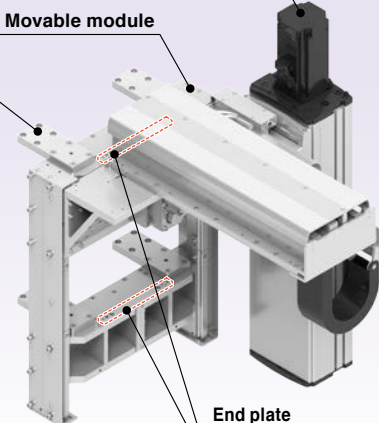

End plate
(For positioning of the module
on the main line side)

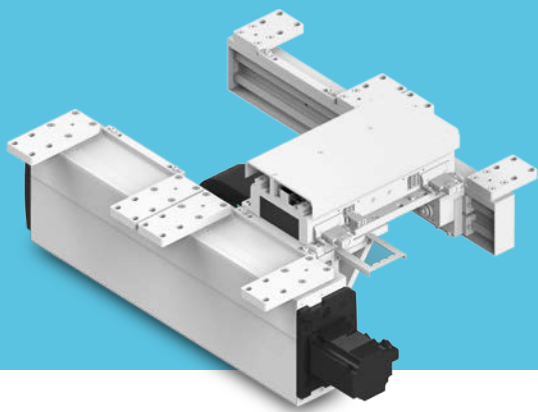

Traversing unit

This unit can branch the production line or pass the process. Improvement and high efficiency of the production line capacity can be achieved.

- | Bottleneck process is resolved to improve the throughput.
- | Sampling inspection and workpiece correction can be performed without stopping the line.

Traversing unit JGX16-T

Branching specifications

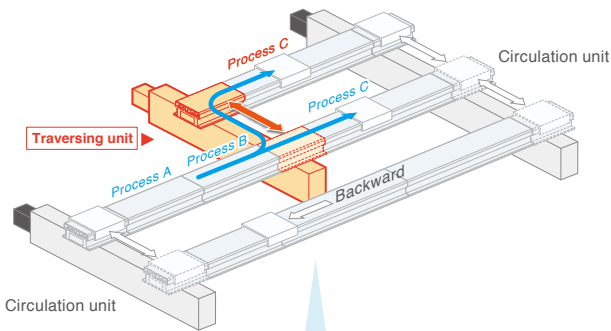

Retracting specifications

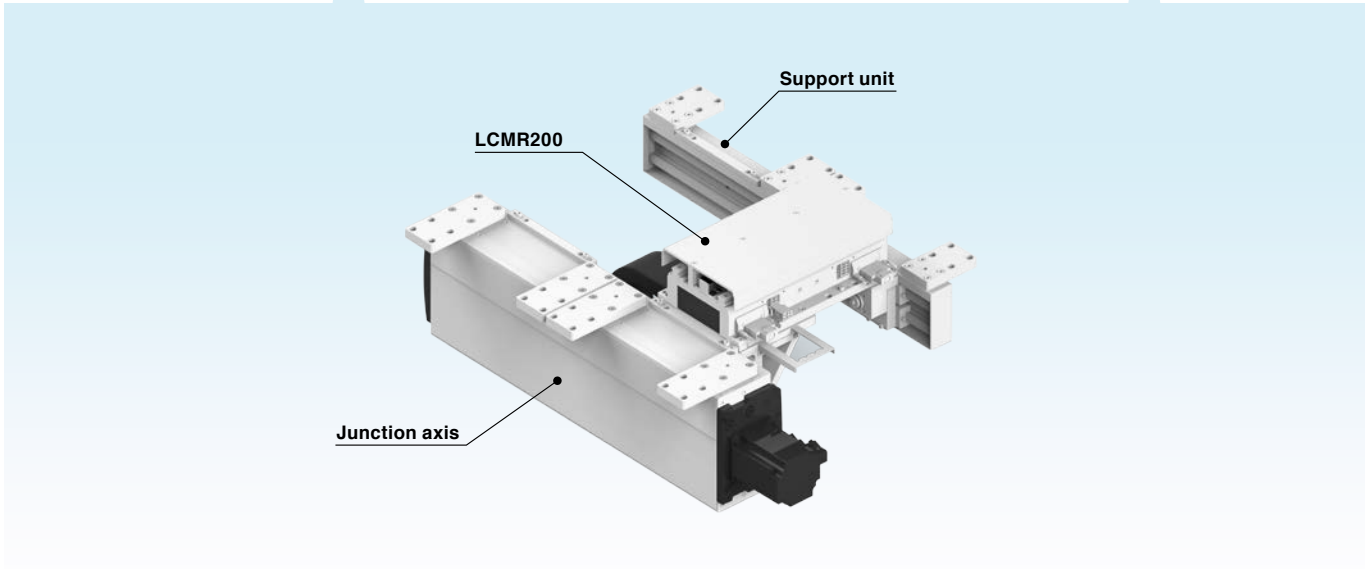
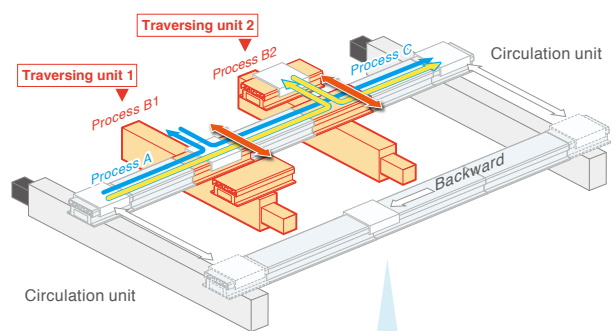

Traversing unit features

About Traversing unit

Circulation unit

- One module moves.
- The slider can access from only one side of the module.

This figure shows that the slider can access from only the right side.

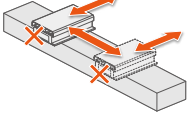

The slider cannot access from the left side of the module.

Traversing unit

Accessible from both sides of the module

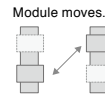
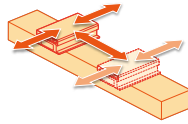

Basic movement pattern

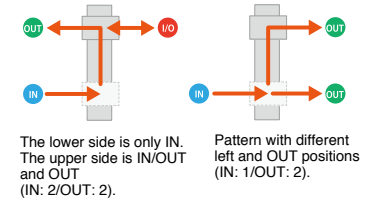

Two modules can also be installed.

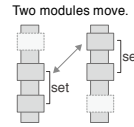
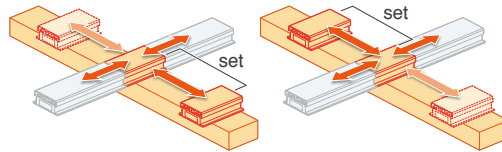

Basic movement pattern

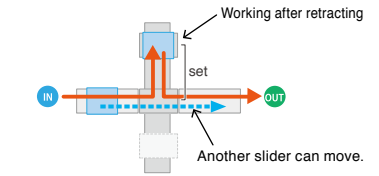

Usage example

Bottleneck is resolved. The production volume is improved by parallelizing processes that inevitably take time.

■ Bottleneck is resolved./Multiple models are supported.

“Improvement of specific process capacity” and “Distribution of line by model” are achieved by branching.

Example of bottleneck resolution

Process C is parallelized to resolve the bottleneck.

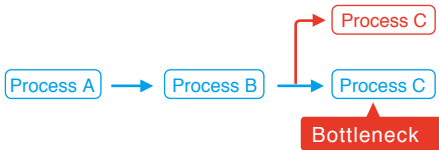

Example of bottleneck resolution

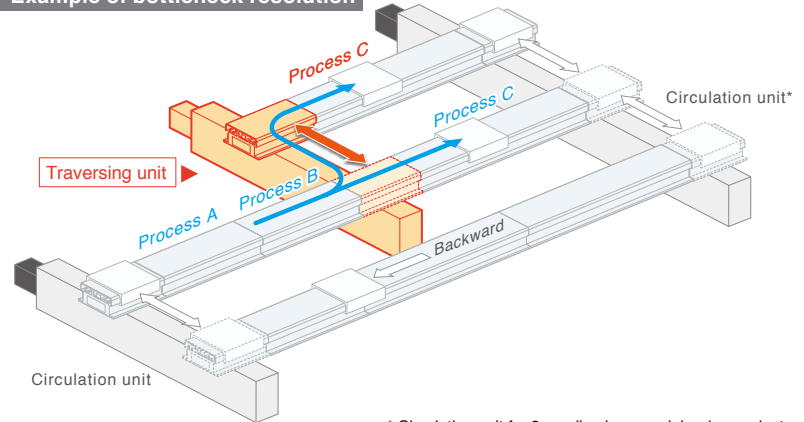

* Circulation unit for 3-row line is a special order product.

■ Bottleneck is resolved.

Passing the slider resolves the bottleneck.

Arranging multiple processes B and passing the working slider resolve the bottleneck.

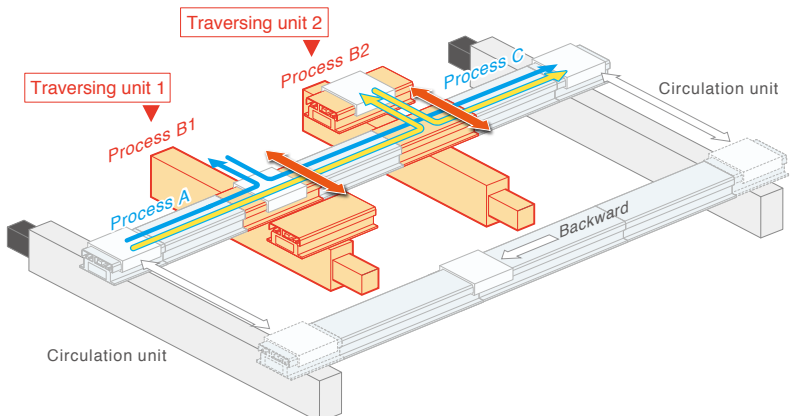
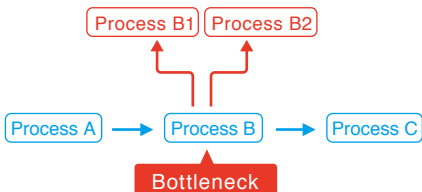

Sampling inspection/correction

The production volume can be maintained while reducing losses.

Correction

NG product delivery ⇒ Correction ⇒ Inspection.
“Production line without waste” is achieved.

OK product



Correction



- Workpiece is retracted to the correction area according to the inspection results.
- Workpiece is returned to before the inspection process again after completion of the correction.

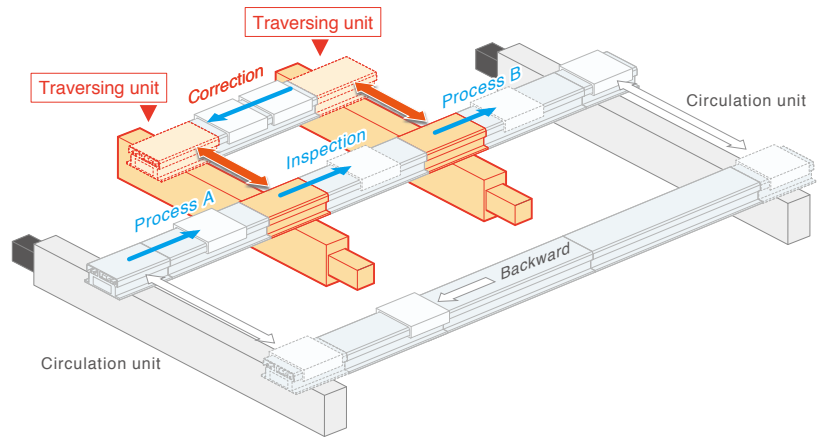

Sampling inspection/correction <Workpiece to be sampled needs to be extracted onto an extension of the line.>

When the jig pallet may be defective, it can be delivered and replaced immediately.
Production line that continuously manufactures OK products is achieved.

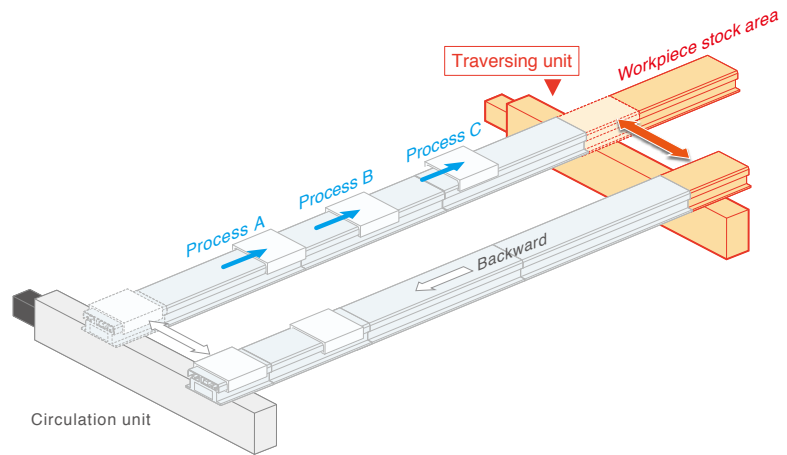
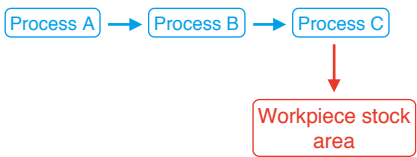

Sampling inspection/correction

Workpieces can be delivered to the workpiece stock area for sampling and correction.
Line that can be handled at a convenient timing on site is achieved.

OK product



Correction



- Workpiece is retracted to the correction area according to the inspection results.
- Workpiece to be used for the sampling inspection is pulled out by the traversing unit.

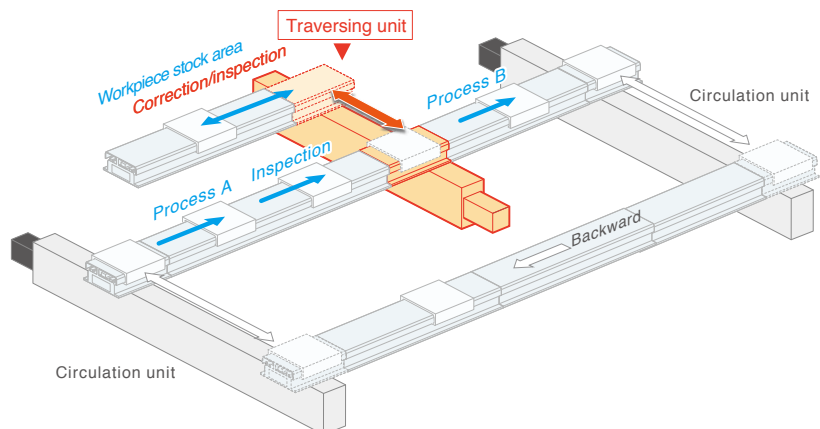



YHX controller

Linear conveyor module "LCMR200" can be controlled via YHX controller from the host PLC.

Reduces production line configuration time

Stacking modular structure

No wiring between modules needed.

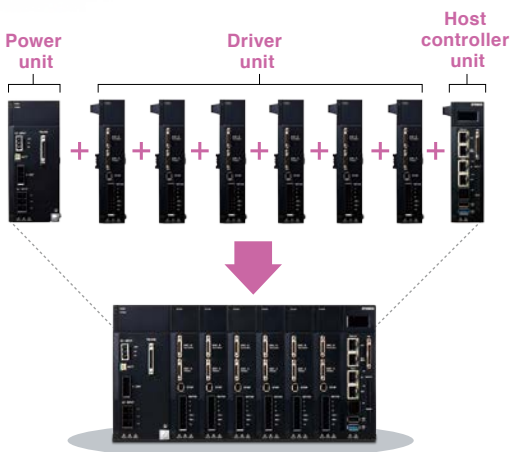

Incorporation a control power supply, motor drive power supply, high speed network communication, safety circuit into a stacking modular structure. Eliminates wiring between units, reducing conventional wiring cost and wiring man-hour to 30% to 50%. The stacking structure including host, power and driver is the very first in the industry.

Typical photo image of stacking structure



Driver unit
up to **16**
units
Stackable

Configuration example

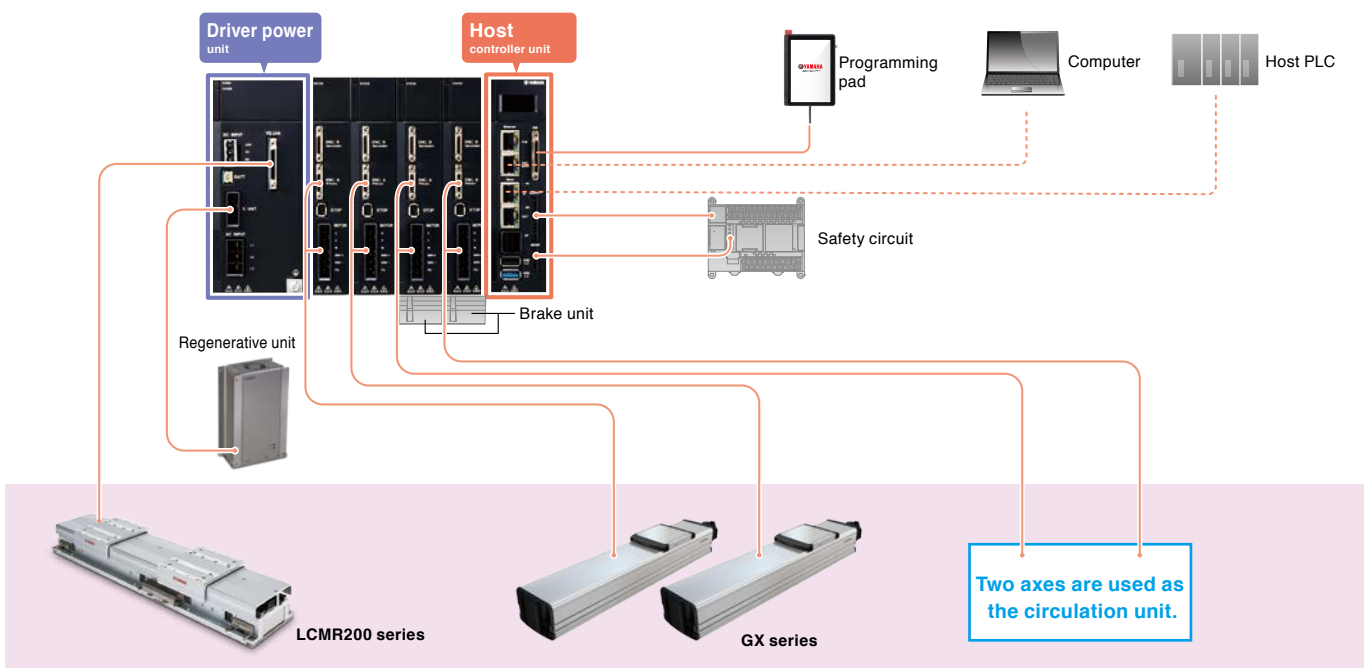

System configuration diagram

Configuration example

One way 2000 mm, vertical circulation transport line
 * 200 mm linear model and single-axis robot are used for circulation section

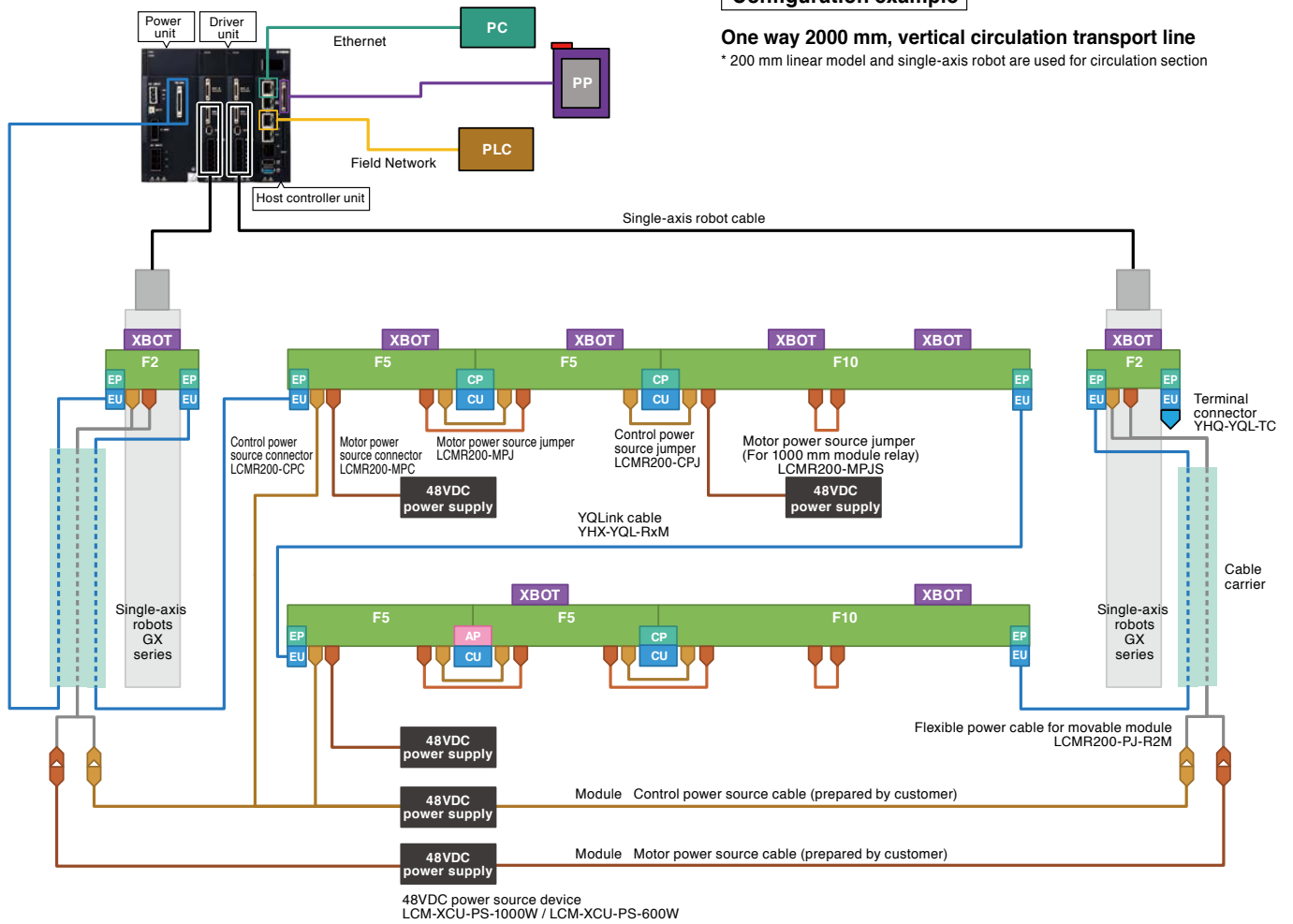

Icon	Name	Description
	Linear module	Size of modules selected here is for reference only. The cable extraction direction can be selected in units of cluster (multiple linear modules are connected to configure one line). A linear module used in the circulation part is also common.
	Robot slider	A slider that operates on the linear module.
	End plate	Position a linear module on both ends of a cluster.
	Connection plate	The adjacent modules are positioned and connected.
	Adjuster plate	This adjuster plate is used to adjust the return line length to match the reference line.
	End unit	Connect with the YQLink cable or YQLink terminal end unit on both ends of a cluster.
	Connection unit	Between module communication of adjacent modules is connected.
	Control power supply connector	A connector to supply control power source from 48 VDC power source to the linear module.
	Control power source jumper	A jumper cable to supply control power source to adjacent modules.
	Motor power source connector	A connector to supply motor power source from 48 VDC power source to the linear module.
	Motor power source jumper	A jumper cable to supply motor power source to adjacent modules.
	Motor power source jumper (for 1000 mm module relay)	A jumper cable to relay motor power source in 1000 mm module. When 3 to 4 robot sliders stop in 1000 mm module, remove this motor power source jumper, and connect the power source device for additional motor with the motor power source connector.
	YQLink cable	A communication cable between each linear module cluster and the controller. As shown in the above figure, connect from left to right with one line. Connect the YQLink end connector to the terminal of the end cluster.
	48 VDC power supply	General-purpose 48 VDC power source device that can be applied to both control and motor operations. With one power source device, 10 m module control power source can be supplied. Also, one power source device can supply motor power source of two robot sliders. Prepare power source devices for each control power source and motor power source.
	Flexible power cable for movable module	Flexible cable to supply power source to the module that performs reciprocal operation mainly in the circulation part.

YHX Standard Profile

What is a standard profile

A project file for LCMR200 that moves a single-axis robot and LCMR200 as a positioner via field network from the host PLC.

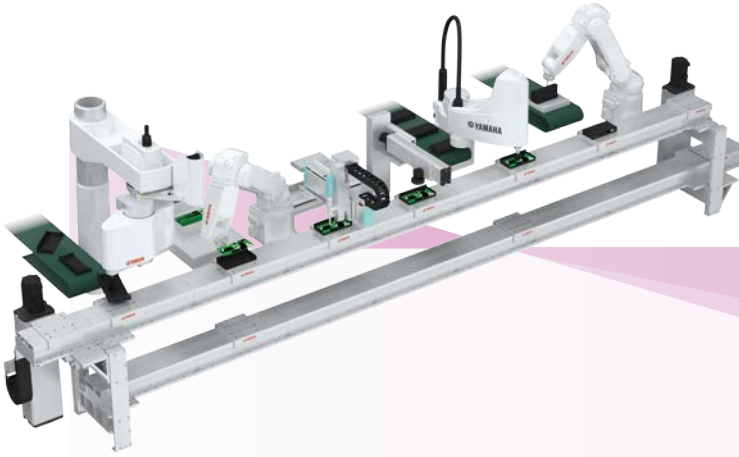

Features of YHX standard profile

- > Eliminates writing ladder logic codes.
- > Adding operation through a pendant.
- > Perform simple direct value operation and specific point-to-point move.
- > Servo ON of any slider individually.
- > Obtain alarm information through the host PLC.



Significant reduction of launching man-hour.

Significant reduction of startup time and process.

Controlled by program creation of the host PLC.

Numbers of improvements in line design and operation.

Implementing a task is simple and easy

Standard profile features

POINT ① LCMR200 can be operated using your familiar PLC.

Use of YHX standard profile makes it possible to operate the LCMR200 from the host unit such as PLC via the I/O interface of each field work.

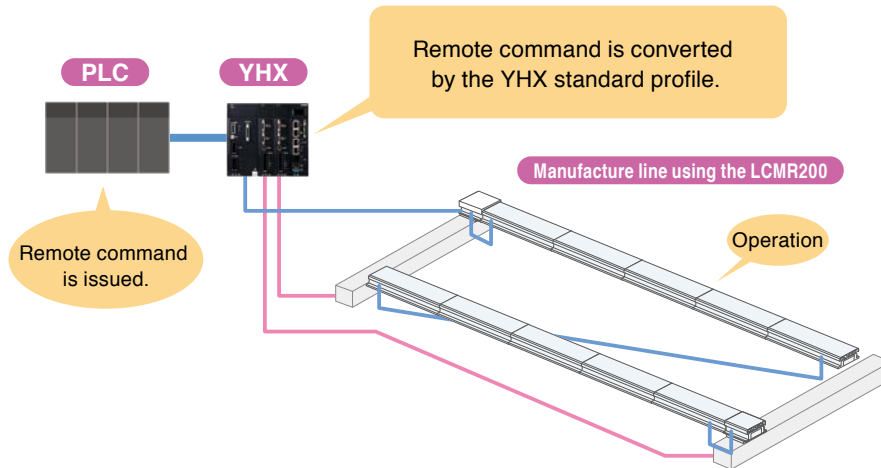

POINT ② Creation of YHX ladder by the customer is not needed.

Dedicated input and output signals are already assigned to the word and bit area of the field network. Operations necessary for the robot motion such as servo ON or JOG movement can be performed without creating programs.

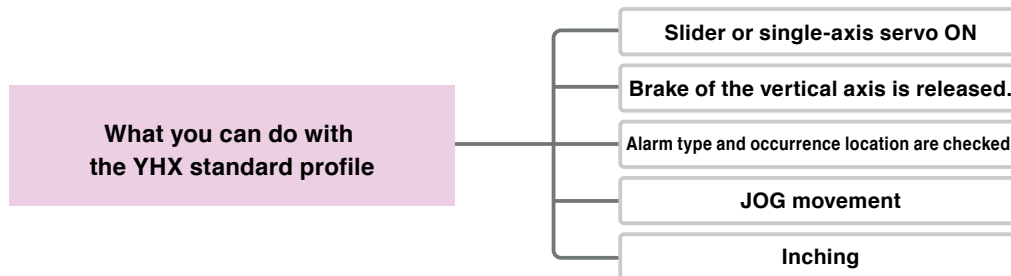

POINT ③ Control using “movement file”

Control is performed using the point data “movement file” necessary to register the target position.

“Movement file” plays a role similar to point data.

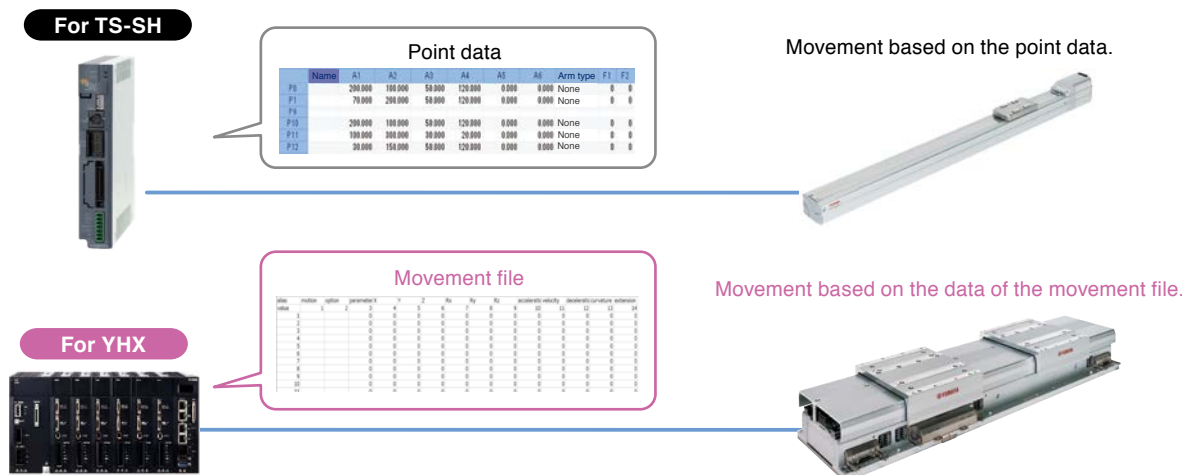

Standard profile features

POINT④ Simple direct value operation and point designation movement can be performed.

About point designation

- The operation pattern for up to 65,535 points in total can be designated.
- The coordinate value, speed, acceleration, deceleration, and tolerance are specified for each point.

Designation image

Point	coordinate value (mm)	Speed	Acceleration	Deceleration	Tolerance (mm)
1	100.000	1	0.5	1	0.01
2	823.500	0.5	1	1	0.05
3	472.000	1	1	1	0.02
4	1834.410	0.5	1	1	0.01
5	2755.350	1	1	1	0.01

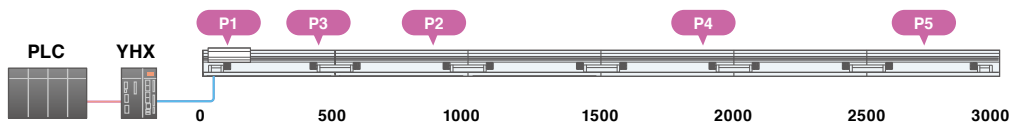

Overview of remote command

Input
1. Command
2. Point designation
3. Direct value position designation

Output
1. Axis status
2. Point output
3. Current position output

1. Servo ON, return-to-origin, movement, JOG, inching, etc.
 2. Point number to be used.
 3. When the direct value is designated, the speed and acceleration use the values stated in 2 and only.
-
1. Servo status, during movement, or movement completion, etc.
 2. Point number during movement
 3. Current position is always output.

Point designation operation

- Next movement point number for each slider is designated.
- This operation is valid when each slider needs to be circulated to the predetermined stop position.

Point	coordinate value (mm)	Speed	Acceleration	Deceleration	Tolerance (mm)
10	500.0	1	0.5	1	0.01
11	1250.0	0.5	1	1	0.05
12	2000.0	1	1	1	0.02
13	2750.0	0.2	1	1	0.01

Step	Slider		
	#01	#02	#03
1	P10	-	-
2	P11	P10	-
3	P12	P11	P10
4	P13	P12	P11

The operation conditions such as coordinate, speed, and acceleration are entered into the point.

Point number is assigned to the slider.

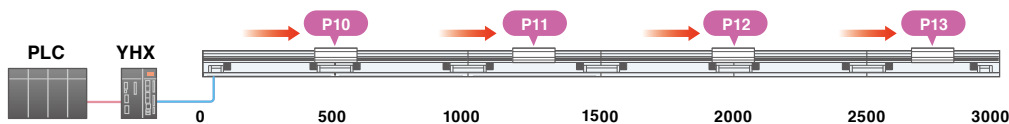

Direct value operation

- The operation conditions such as speed are specified by the points and the target coordinates are directly specified by the numeric values.
- This operation is valid when each slider position is managed by the PLC or when the stop position needs to be changed as required.

Point	coordinate value (mm)	Speed	Acceleration	Deceleration	Tolerance (mm)
10	500.0	1	0.5	1	0.01
11	1250.0	0.5	1	1	0.05
12	2000.0	1	1	1	0.02
13	2750.0	0.2	1	1	0.01

Step	Slider#01		Slider#02		Slider#03	
	Point	coordinate value (mm)	Point	coordinate value (mm)	Point	coordinate value (mm)
1	P10	500.0	-	-	-	-
2	P11	1250.0	P10	510.0	-	-
3	P12	2000.0	P11	1260.0	P10	500.0
4	P13	2750.0	P12	2010.0	P11	1250.0

The operation conditions are registered for the points and the target coordinates are specified separately.

Operation conditions: Registered point is referred to. + Target position: Directly specified by the numeric values.

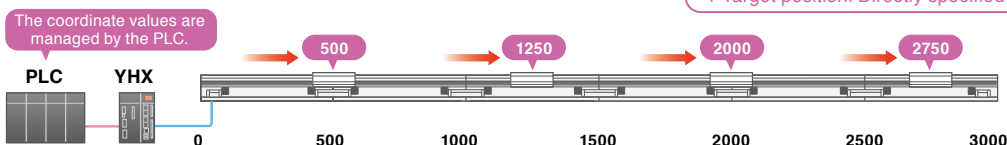

The coordinate values are managed by the PLC.

POINT 5 JOG or inching operation can be performed from the pendant even when no PLC is connected.

Even in a status where no PLC is connected, the axis can be operated using the JOG or inching operation from the programming pad.
 When the LCMR200 is used for the circulation layout, the necessary adjustment work can be performed immediately.

POINT 6 Prevention of operation leading to damage to the circulation section is supported.

Registering the pallet size to the parameter determines the slider operable area. Even when a pallet or workpiece is larger than the overall length of the slider, a circulation operation failure can be detected.
 This avoids any slider transfer accident of the circulation unit and allows for safer software design.

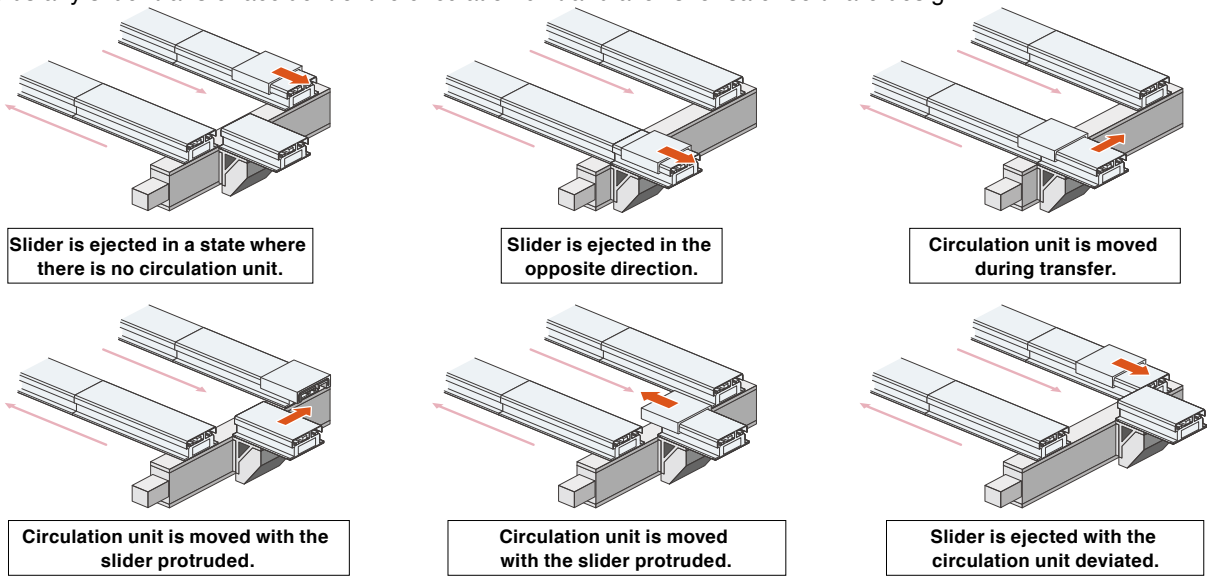

Process

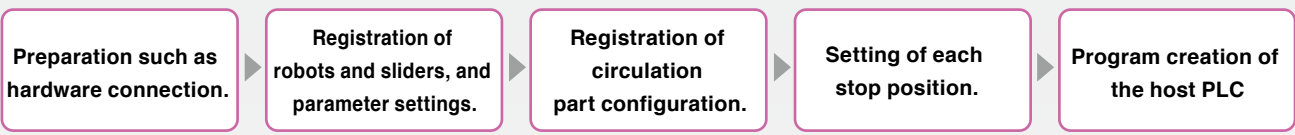

Standard profile specification

Applicable controller	YHX-HCU	
Operation method	Point trace point No. specified positioning and direct value coordinate specified positioning.	
Comparative robot	LCMR200, LCM-X and GX series (LCMR200 and LCM-X cannot be controlled together).	
Interface	YHX Studio, YHX-PP, and field network communication	
Operation type	Absolute position moving	
Maximum number of points that can be registered.	65535	
No. of control axes (Total of sliders and single-axis robots, however, up to 16 axes for single-axis robot)	EtherCAT	64
	EtherNet/IP™	64
	PROFINET	64
	CC-Link	22
Main input and output See the manual for other functions.	All axes target input	Servo ON/OFF switch/Interlock/Alarm reset
	All axes target output	Servo State/Interlock State/Alarm State/Heart beat/Emergency stop State
	Individual axis target input	Servo ON/OFF switch/Return to Origin/Positioning moving inside the control range (including LCM relay operation)/Slider insertion preparation from outside the control range/Slider discharge to outside the control range/Jog movement, inching movement/Movement Stop
Individual axis target output	Servo State/Return to origin State/Output specified point No. for various execution state display/Current position/Axis alarm State	
Main remote command See the manual for other remote commands.	Writing/reading of setting data	
	Alarm check	
	Writing and reading of integrated running distance and No of transits.	

Basic specifications of LCMR200

Basic specifications of LCMR200

Drive method	Linear motor with moving magnet type core	
Position Search	Magnetic absolute position sensor	
Maximum payload	30 kg	
Maximum speed	2,500 mm/sec ^{*1}	
Repeatability	+/-5 μm	
Mechanical tolerance between robot sliders	+/-30 μm (Dowel hole standard)	
Total stroke limit	25.5 m ^{*2}	
Maximum number of robot sliders	64 units ^{*2}	
Minimum spacing between robot sliders	210 mm ^{*3}	
Main frame dimensions	Max. external size of frame cross-section	W175 × H109 mm (Including robot slider)
	Linear module length	200 mm / 300 mm / 500 mm / 1000 mm
	Robot slider length	198 mm
Weight	Linear module	Approx 20 kg (Per 1 m of linear module)
	Robot slider	2.4 kg
Power supply	Control power supply	48 VDC Required power [W] = 75 [W/m] x Overall length of module [m] ^{*4}
	Motor power supply	48 VDC Yamaha's designated model ^{*5}
Operating environment	Operating temperature	0 °C to 40 °C ^{*6}
	Storage temperature	-10 °C to 65 °C
	Operating humidity	35 % to 85 %RH (No condensation)
Controller	YHX controller ^{*7}	

- *1. When the conveying weight exceeds 10 kg, it will drop to 1,000 mm/sec according to the weight.
- *2. It may differ depending on the system configuration.
- *3. When the jig palette to equip to the robot slider is longer, it shall be the jig palette length + 10 mm.
- *4. The option 600 W power source supplies the power to the linear module with a length of up to 8 m while the 1000 W power source supplies the power to the linear module with a length of up to 13.3 m.
- *5. The option power source can supply the power to up to two robot sliders. (When AC 200 to 240 V is input.)
- *6. Operate LCMR200 in the temperature environment (+/-5 °C) that installation and adjustment were performed.
- *7. The YHX controller requires a separate electrical power supply.

Static loading moment

Static loading moment [N·m]		
MP	MY	MR
47.0	35.7	31.4

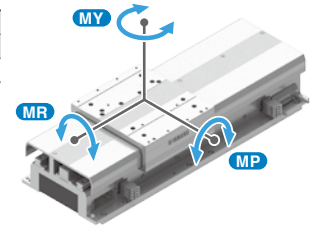

Allowable overhang

payload [kg]	Allowable overhang [mm]		
	A	B	C
5	760	405	239
10	762	231	158
15	700	173	122
20	648	117	73
25	509	82	68
30	453	58	49

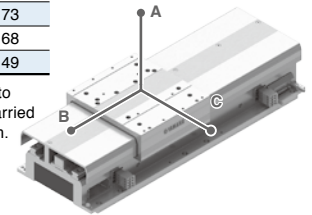

* Distance from center of slider top to center of gravity of object being carried at a guide service life of 10,000 km.

Allowable Load of LCMR200

- * When center of slider is center of gravity.
- * Allowable load in the moving direction of slider is always 28 N regardless of the loading position.
- * Any load cannot be applied to the slider on the movable module of YAMAHA's circulation unit in both the horizontal and vertical directions.
- Vertical load variation within the slider payload is possible due to loading or unloading of workpieces to or from the slider on the movable module. However, do not insert or eject the slider to or from the movable module while the load is varying.
- * Only vertical load can be applied to the slider on the movable module of YAMAHA's traverse unit within the range shown in the table below. Do not insert or eject the slider to or from the movable module while the load is being applied.

Load: Horizontal Direction

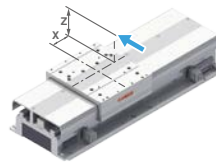

■ Payload: Common up to 30 kg.

Loading Position X [mm]	Loading Position Z [mm]					
	0	20	40	60	80	100
0	611	514	443	390	348	314
20	517	445	391	349	315	287
40	447	393	350	316	288	264
60	394	352	317	289	265	245
80	353	318	289	266	245	228
100	319	290	266	246	229	214

Unit: [N]

Load: Vertical Direction

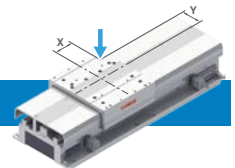

■ Payload: 5 kg

Loading Position X [mm]	Loading Position Y [mm]					
	0	20	40	60	80	100
0	924	687	546	453	387	339
20	760	593	485	411	356	314
40	647	521	436	375	328	293
60	562	465	396	345	305	274
80	498	420	362	319	285	258
100	446	382	335	297	268	243

■ Payload: 10 kg

Loading Position X [mm]	Loading Position Y [mm]					
	0	20	40	60	80	100
0	874	650	517	429	367	320
20	721	561	459	389	337	297
40	613	493	413	355	311	277
60	533	440	375	327	289	260
80	471	397	343	303	270	244
100	423	362	317	282	254	231

■ Payload: 15 kg

Loading Position X [mm]	Loading Position Y [mm]					
	0	20	40	60	80	100
0	826	614	488	406	347	303
20	680	529	433	367	318	281
40	578	466	390	335	294	261
60	503	416	354	309	273	245
80	445	375	324	285	255	231
100	399	342	299	266	239	217

Unit: [N]

■ Payload: 20 kg

Loading Position X [mm]	Loading Position Y [mm]					
	0	20	40	60	80	100
0	777	578	459	381	326	285
20	640	498	408	345	299	264
40	544	438	367	315	277	246
60	473	391	333	290	257	231
80	419	353	305	269	240	217
100	376	322	281	250	225	205

■ Payload: 25 kg

Loading Position X [mm]	Loading Position Y [mm]					
	0	20	40	60	80	100
0	728	540	431	358	305	267
20	599	466	382	323	281	247
40	509	410	344	295	259	231
60	443	366	312	272	240	216
80	392	331	286	252	225	203
100	352	302	264	234	211	192

■ Payload: 30 kg

Loading Position X [mm]	Loading Position Y [mm]					
	0	20	40	60	80	100
0	678	505	401	333	285	249
20	560	435	356	302	261	231
40	476	382	321	276	241	215
60	413	341	291	253	225	201
80	366	309	266	235	210	190
100	328	281	246	219	197	179

Unit: [N]

Configuration parts of LCMR200

LCMR200 Main Body



Linear module

Length	Front* cable extraction	Rear* cable extraction
	Model	
200mm	LCMR200-F2	LCMR200-B2
300mm	LCMR200-F3	LCMR200-B3
500mm	LCMR200-F5	LCMR200-B5
1000mm	LCMR200-F10	LCMR200-B10

* Check "Front line" on the side of the linear module. (See page 29.)
The motor power source connector is attached to the module.

Robot slider



Model	LCMR200-XBOT-****
Parts No.	KNA-M2264-**

When ordering the robot slider, specify slider ID number 1001 to 1139 in the last 4 digits "****" section of the model.

ID, model, and parts No. correspondence example		
ID	Model	Parts No.*
1001	LCMR200-XBOT-1001	KNA-M2264-01
1002	LCMR200-XBOT-1002	KNA-M2264-02
1099	LCMR200-XBOT-1099	KNA-M2264-99
1100	LCMR200-XBOT-1100	KNA-M2264-A0
1112	LCMR200-XBOT-1112	KNA-M2264-B2

ID 110s are A*.
ID 111s are B*.
ID 112s are C*.
ID 113s are D*.

YQLink cable

YQLink movable cable

This cable connects the controller (YHX) and linear conveyor module.
Refer to the system configuration drawing for a connection example.



Cable length	Model	Parts No.
0.3m	YHX-YQL-R0.3M	KFA-M5361-P1
3m	YHX-YQL-R3M	KFA-M5361-31
7m	YHX-YQL-R7M	KFA-M5361-71
10m	YHX-YQL-R10M-N	KFA-M5361-A1

YQLink fixation cable

Cable length	Model	Parts No.
15m	YHX-YQL-M15M	KNA-M5362-F0

YQLink terminating connector

Model	Parts No.
YHX-YQL-TC	KFA-M5361-00

Other power source options

Module electric power supply (48 VDC-1000 W)

Unit type general purpose power supply corresponding to the peak output that is applicable to both the module control and motor power. Select a power supply suitable for the required power and equipment installation conditions by considering the supply capacity and outside dimensions per application of each power supply.

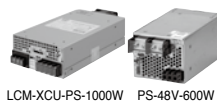

- Rated output 600 W/1000 W, Efficiency > 80%, Power factor > 90%
- When AC 200 to 240 V is input, the peak maximum output is 42 A (within 5 seconds).

Supply capacity		Model	Parts No.
Control power supply [Rated output]	Motor power supply [Peak maximum output]		
Cluster within 8m [600W]	Within 2 sliders [1992W]	PS-48V-600W	KNA-M6561-00
Cluster within 13.3 m [1000W]	Within 2 sliders [2016W]	LCM-XCU-PS-1000W	KFA-M6561-00

Flexible power cable for movable module

Model	Parts No.
LCMR200-PJ-R2M	KNA-M539H-21

LCMR200 Connection Parts

Module connection kit

Model	Parts No.	Configuration parts
LCMR200-CKIT	KNA-M2043-C0	Connection unit Connection plate Motor power source jumper Control power source jumper

Module terminal kit*

Model	Parts No.	Configuration parts
LCMR200-EKIT	KNA-M2043-E0	End unit x2 End plate x2 Control power supply connector

* When a circulation unit made by Yamaha is not used, one terminal kit is necessary for one cluster. The components for two terminal kits are assembled to or supplied with Yamaha circulation unit.

Adjuster kit*

Model	Parts No.	Configuration parts
LCMR200-AKIT	KNA-M2043-A0	Connection unit Adjuster plate Motor power source jumper Control power source jumper

Return line length	Number of adjuster kit
3 m or less	1
More than 3 m and 14 m or less	2
More than 14 m and 25.5 m or less	3

* For the return line, use the specified number of adjuster kit according to the return line length.
For details about the usage location and how to use, see the user's manual.

Maintenance items*

Control power supply connector

Model	Parts No.
LCMR200-CPC	KNA-M4431-00

Control power source jumper

Model	Parts No.
LCMR200-CPJ	KNA-M4421-10

Motor power source connector

Model	Parts No.
LCMR200-MPC	KNA-M4432-00

Motor power source jumper

Model	Parts No.
LCMR200-MPJ	KNA-M4422-10
LCMR200-MPJS (for 1000 mm module relay)	KNA-M4422-20

End plate

Model	Parts No.
LCMR200-EP	KNA-M22GM-E0

Connection plate

Model	Parts No.
LCMR200-CP	KNA-M22GM-C0

Adjuster plate

Model	Parts No.
LCMR200-AP	KNA-M22GM-A0

End unit

Model	Parts No.
LCMR200-EU	KNA-M2040-E0

Connection unit

Model	Parts No.
LCMR200-CU	KNA-M2040-C0

* These are single models of parts included in the module connection kit, adjuster kit, module terminal kit, circulation unit, or module main body.

External view of LCMR200

LCMR200 Module connection and installation

Front* cable extraction

LCMR200-F**

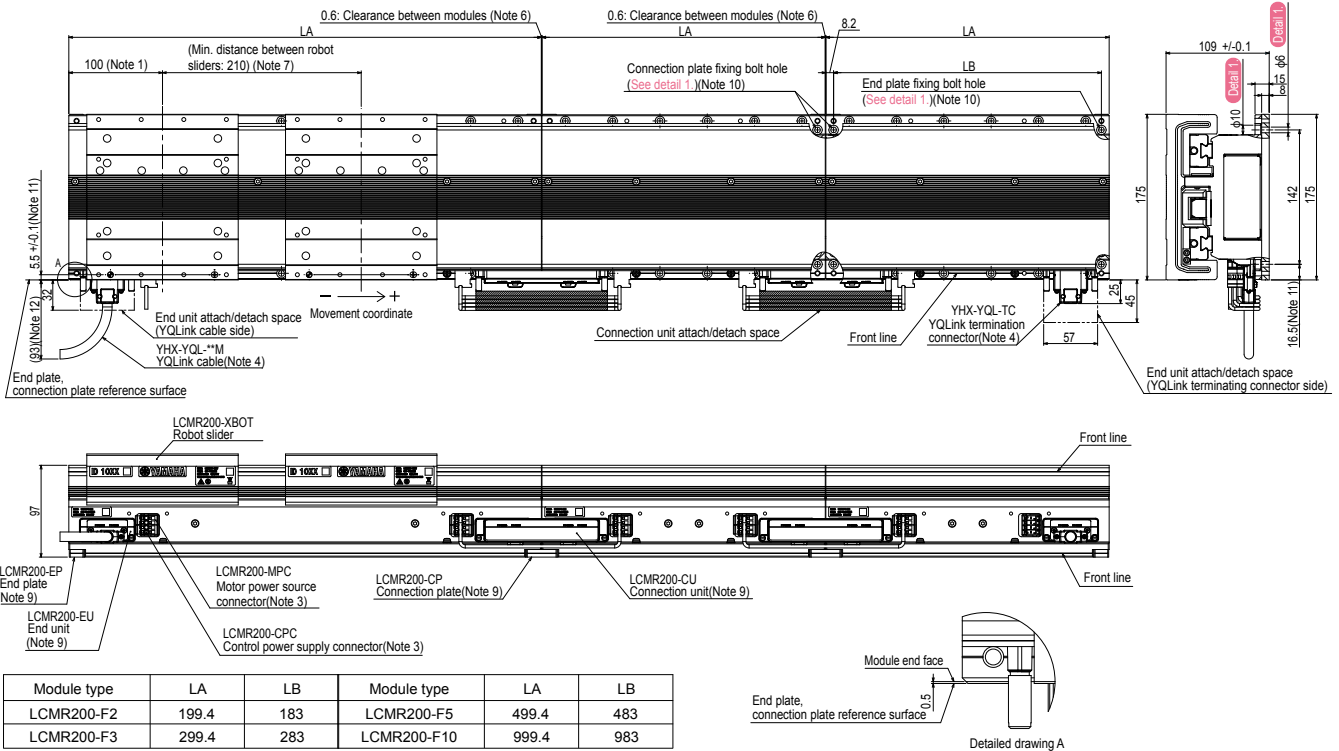

Linear module

Front* cable extraction

LCMR200-F2

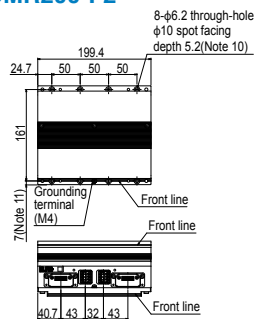

LCMR200-F3

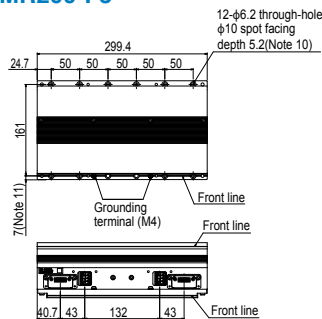

LCMR200-F5

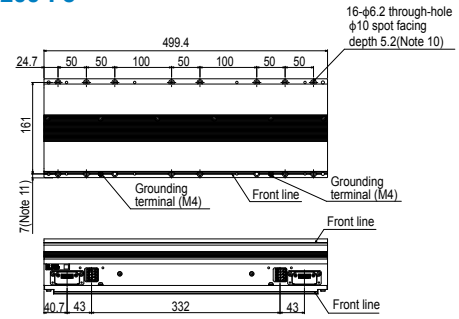

LCMR200-F10

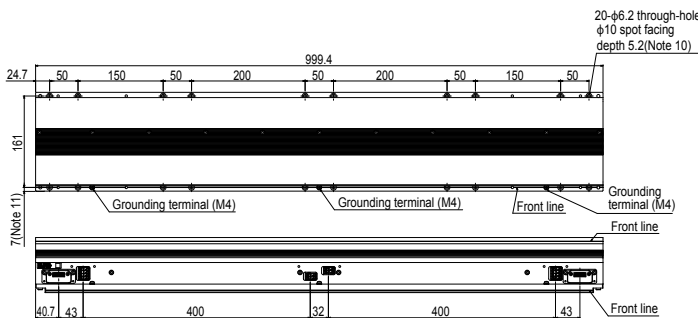

- Note 1. The robot slider unstoppage range of 100 mm from both ends of the cluster may vary depending on the pallet length. However, when there is no adjacent cluster, the robot slider unstoppage range is 82.5 mm regardless of the pallet length. For details, see the manual.
 - Note 2. Module types can be freely combined within the same cluster after the front and rear of the cable extraction direction have been aligned.
 - Note 3. The control power source and motor power source can be passed and received by the jumper connector. See the manual for detail of passing and receiving.
 - Note 4. For the YQLink cable and YQLink terminating connector connection location, see the manual.
 - Note 5. Sixty-four robot sliders can be installed in a system connected by the YQ Link cables * (depending on the number of robots that are controlled by the same controller).
 - Note 6. Where modules are connected with the connection plate, the clearance between the adjacent modules is 0.6 mm.
 - Note 7. The minimum pitch of each slider at the stopping state is 210 mm; however, when they start at the same time, they may collide due to operation conditions, and conditions such as command timing from the upper PLC, programming with YHX, etc. In the case, it is necessary to adjust by securing more distance (pitch) between the sliders, changing the start timing (sequential start), etc.
 - Note 8. There is no mechanical stopper due to the nature of the product. Please install a mechanical stopper by the customer as needed.
 - Note 9. The connection plate and connection unit are used to connect the modules, and the end plate and end unit are used at the cluster end.
 - Note 10. To secure the module, end plate, connection plate, and adjuster plate to the base, use M5 hexagon socket head cap bolts.
 - Note 11. Distance from the end plate reference surface, connection plate reference surface and adjuster plate reference surface to the counterbore hole for the module clamp bolt.
 - Note 12. The YQLink movable cable is used. When the YQLink fixation cable is used, the distance is 104 mm.
- * It may differ depending on the system configuration.
* Check "Front line" on the side of the linear module.

LCMR200 Module connection and installation

Rear* cable extraction

LCMR200-B**

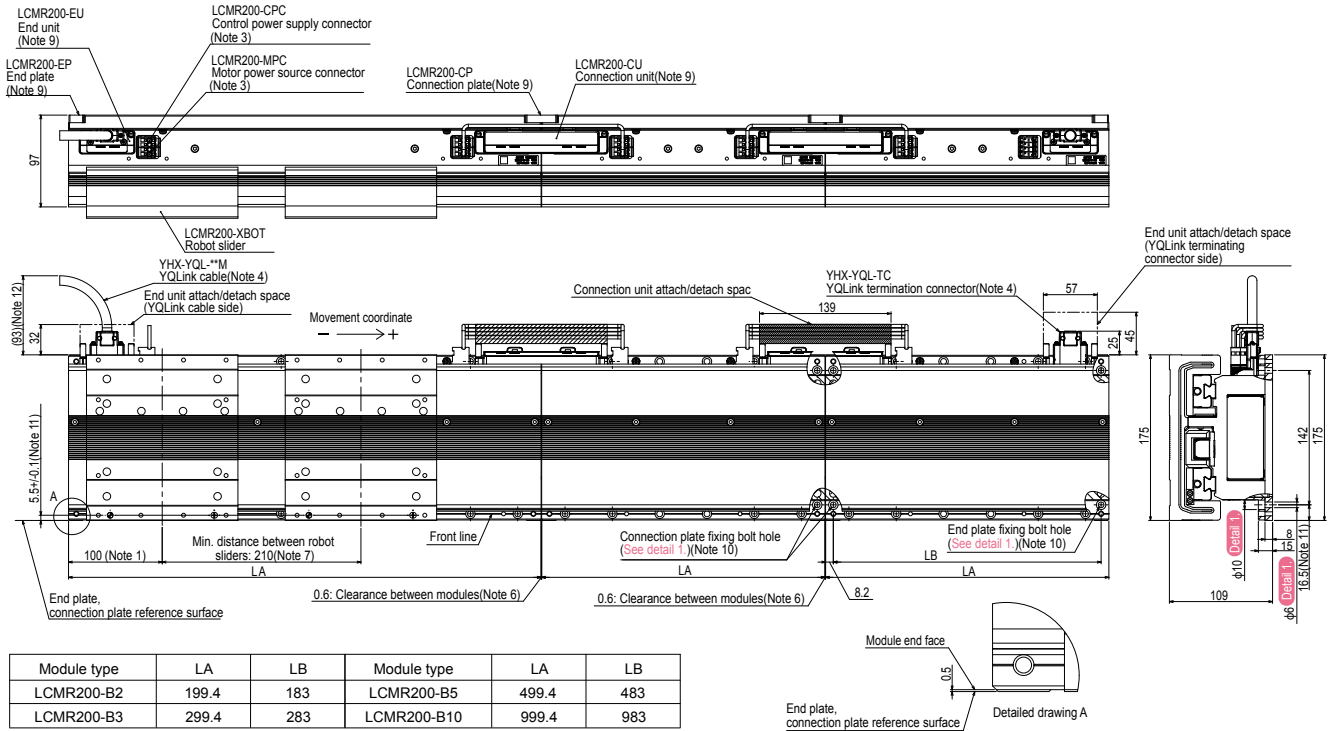

Linear module

Rear* cable extraction

LCMR200-B2

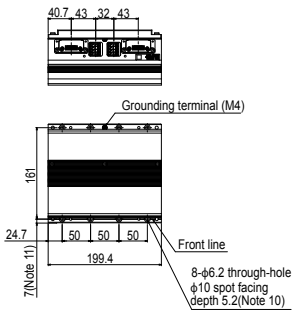

LCMR200-B3

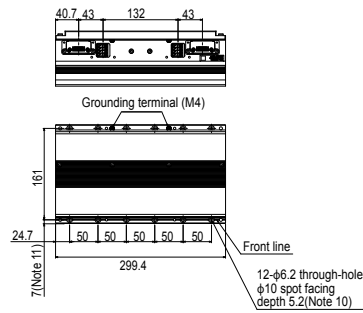

LCMR200-B5

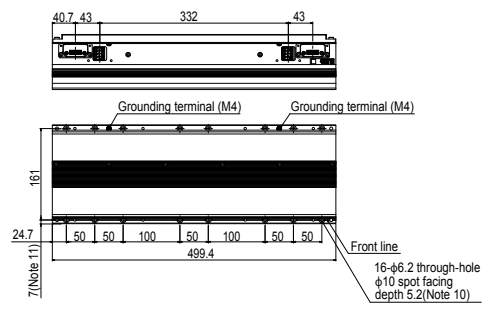

LCMR200-B10

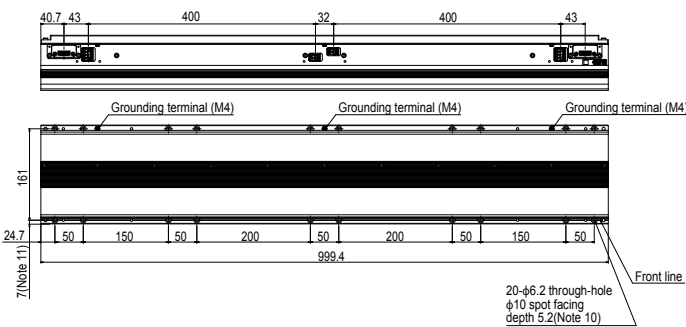

- Note 1. The robot slider unstoppage range of 100 mm from both ends of the cluster may vary depending on the pallet length. However, when there is no adjacent cluster, the robot slider unstoppage range is 82.5 mm regardless of the pallet length. For details, see the manual.
 - Note 2. Module types can be freely combined within the same cluster after the front and rear of the cable extraction direction have been aligned.
 - Note 3. The control power source and motor power source can be passed and received by the jumper connector. See the manual for detail of passing and receiving.
 - Note 4. For the YQLink cable and YQLink terminating connector connection location, see the manual.
 - Note 5. Sixty-four robot sliders can be installed in a system connected by the YQ Link cables * (depending on the number of robots that are controlled by the same controller).
 - Note 6. Where modules are connected with the connection plate, the clearance between the adjacent modules is 0.6 mm.
 - Note 7. The minimum pitch of each slider at the stopping state is 210 mm; however, when they start at the same time, they may collide due to operation conditions, and conditions such as command timing from the upper PLC, programming with YHX, etc. In the case, it is necessary to adjust by securing more distance (pitch) between the sliders, changing the start timing (sequential start), etc.
 - Note 8. There is no mechanical stopper due to the nature of the product. Please install a mechanical stopper by the customer as needed.
 - Note 9. The connection plate and connection unit are used to connect the modules, and the end plate and end unit are used at the cluster end.
 - Note 10. To secure the module, end plate, connection plate, and adjuster plate to the base, use M5 hexagon socket head cap bolts.
 - Note 11. Distance from the end plate reference surface, connection plate reference surface and adjuster plate reference surface to the counterbore hole for the module clamp bolt.
 - Note 12. The YQLink movable cable is used. When the YQLink fixation cable is used, the distance is 104 mm.
- * It may differ depending on the system configuration.
 * Check "Front line" on the side of the linear module.

LCMR200 Features
 Circulation unit Features
 Traversing unit Features
 YHX Features
 LCMR200 Specifications
 Circulation unit Specifications
 Traversing unit Specifications
 JcM accuracy measurement jig
 Others
 YHX Specifications

External view of LCMR200

Robot slider

LCMR200-XBOT

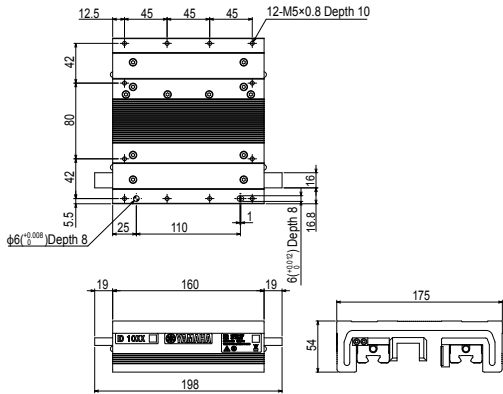

End plate

LCMR200-EP

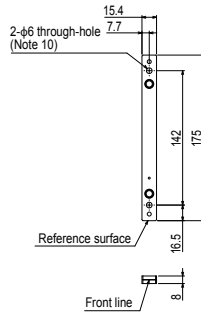

Connection plate

LCMR200-CP

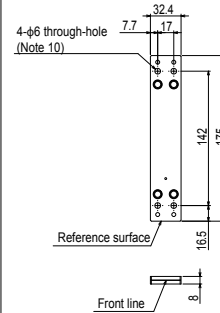

Adjuster plate

LCMR200-AP

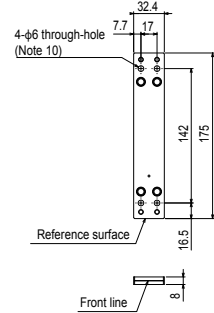

Note 13. The overall length of the line after the modules have been connected using the adjuster plates can be adjusted. For details, see the manual.

End unit

LCMR200-EU

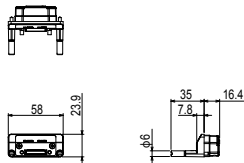

Connection unit

LCMR200-CU

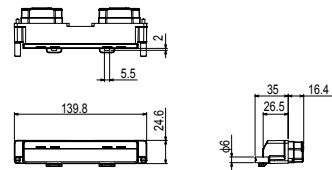

YQLink movable cable

YHX-YQL-R□M (Only 10 m for R10M-N)

Within □	Cable length
0.3	0.3m
3	3m
7	7m
10	10m

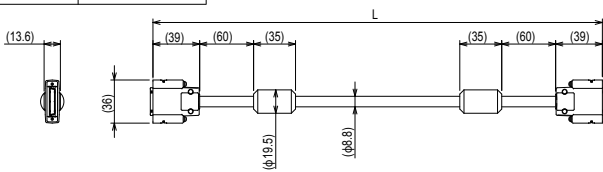

YQLink fixation cable

YHX-YQL-M15M

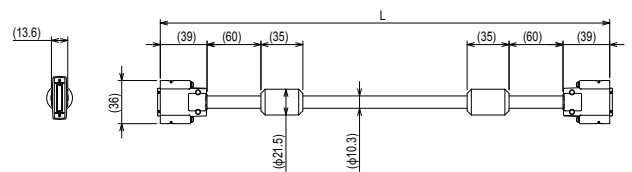

Flexible power cable for movable module

LCMR200-PJ-R2M

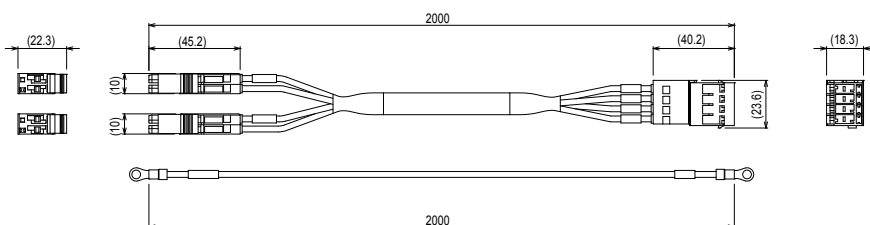

Control power supply connector / Motor power source connector

LCMR200-CPC/LCMR200-MPC

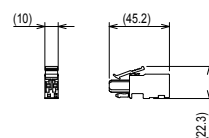

Module electric power supply (DC48V-600W)

PS-48V-600W

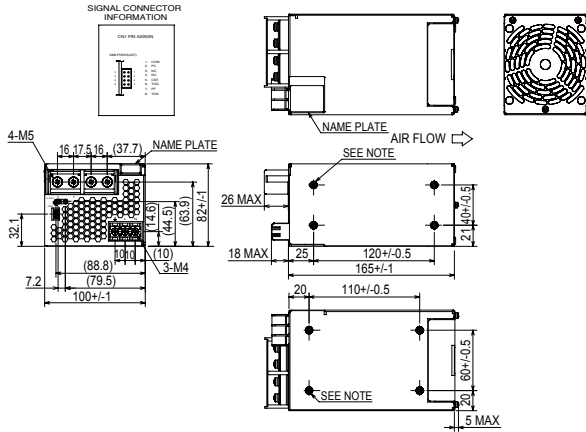

Note. M4 tap holes for installing the customer's chassis (8 locations)
(The maximum screw thread depth is 6 mm.)

Module electric power supply (DC48V-1000W)

LCM-XCU-PS-1000W

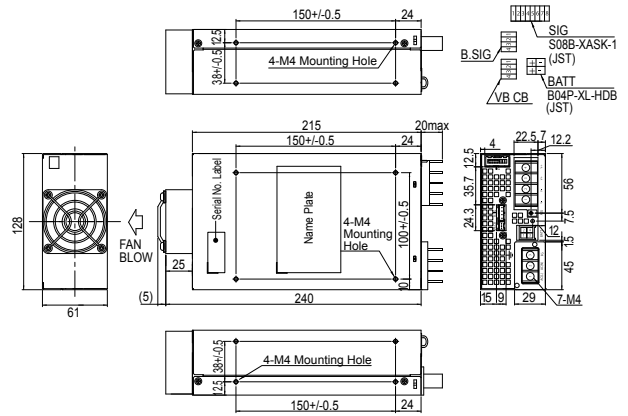

How to distinguish between the front and rear of the linear module

A line that indicates the front (hereafter referred to as front line) is provided at the position of the linear module shown in the figure below. The side with the front line is the front and the one without it is the rear.

- * When linear modules are connected, each front/rear must be oriented uniformly.
- * When viewed from the front of the linear module, the left side is the minus side of the coordinate polarity and the right side is its plus side.

LCMR200-F

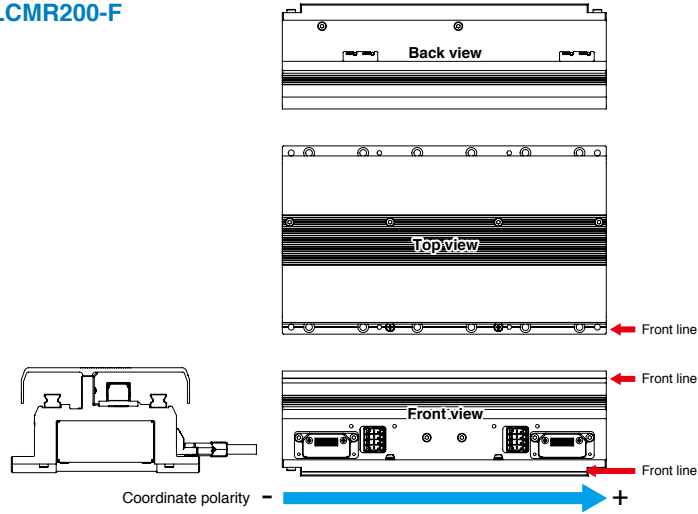

LCMR200-B

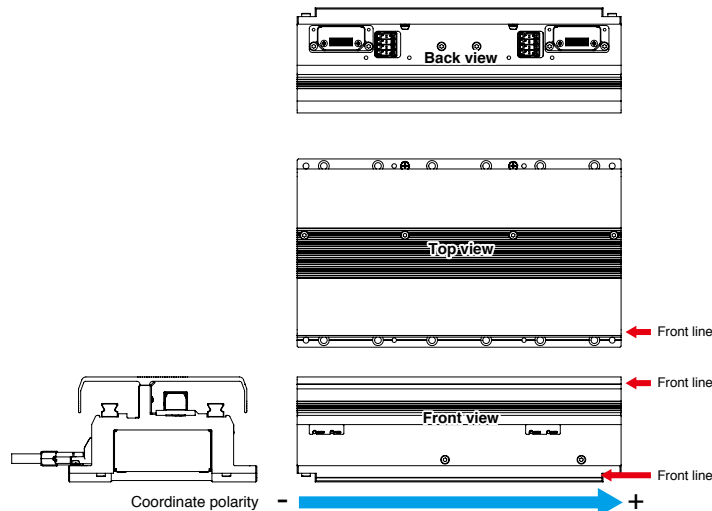

Circulation unit Order model

Horizontal circulation

JGX16

Axis main body	Combination ①	Circulation installation position ②	Lead designation	Single-axis motor specification	Circulation pitch *1	Robot cable length	Robot cable lead-out direction
	H1: Front of motor H2: Rear of motor	L: Left installation R: Right installation	40: 40mm 20: 20mm	Blank: Battery-less absolute S: Standard specification	20 to 135cm	R3: 3m R5: 5m R10: 10m	F: Front of motor R: Rear of motor

LCMR200

LCM main body	Variation	YQLink cable length (IN side) ③	YQLink cable length (OUT side) ③	Driver	Brake unit	Battery *3
	F2: 200 mm (Front cable lead-out) F3: 300 mm (Front cable lead-out) F5: 500 mm (Front cable lead-out) B2: 200 mm (Rear cable lead-out) B3: 300 mm (Rear cable lead-out) B5: 500 mm (Rear cable lead-out)	3: 3m 7: 7m A: 10m	3: 3m 7: 7m A: 10m T: Termination connector *2	A30: YHX-A30-SET	N: None	B: With battery N: None

A30 N

Vertical circulation

JGX16

Axis main body	Combination ④	Circulation installation position ②	Lead designation	Single-axis motor specification	Circulation pitch *1	Robot cable length	Robot cable lead-out direction
	V1: Rear of axis/Above motor V2: Rear of axis/Under motor V3: Rear of axis/Above motor/Folding V4: Front of axis/Above motor V5: Front of axis/Under motor V6: Front of axis/Above motor/Folding	L: Left installation R: Right installation	20: 20mm 10: 10mm	Blank: Battery-less absolute S: Standard specification	30 to 60cm	R3: 3m R5: 5m R10: 10m	F: Front of motor R: Rear of motor

LCMR200

LCM main body	Variation	YQLink cable length (IN side) ③	YQLink cable length (OUT side) ③	Driver	Brake unit	Battery *3
	F2: 200 mm (Front cable lead-out) F3: 300 mm (Front cable lead-out) F5: 500 mm (Front cable lead-out) B2: 200 mm (Rear cable lead-out) B3: 300 mm (Rear cable lead-out) B5: 500 mm (Rear cable lead-out)	3: 3m 7: 7m A: 10m	3: 3m 7: 7m A: 10 T: Termination connector *2	A30: YHX-A30-SET	V: With brake unit	B: With battery N: None

A30 V

*1 Cautions on circulation pitch

- Specify the same distance as that between the forward and backward movements of the equipment for the circulation pitch.
- The transfer cannot be stopped at a location other than the specified circulation pitch.
- After delivery, the customer cannot adjust the circulation pitch.
- The circulation pitch is selected at increments of 5 cm.

*2 The termination connector can be selected only when the circulation installation position is R (right installation).

*3 When the battery-less absolute is selected, no battery is needed.

■ Left/right and front/rear are based on when the front line of the module is placed on the front of the system.



① Combination

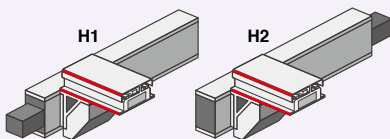

② Circulation installation position

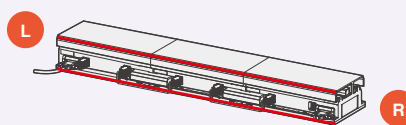

When the front line is placed on the front, the left side of the main line is L while its right side is R.

③ Length of YQLink cable

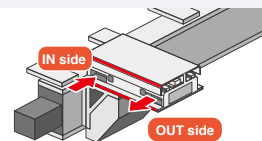

When the front line is placed on the front, the left side is the IN side while the right side is the OUT side.

④ Combination

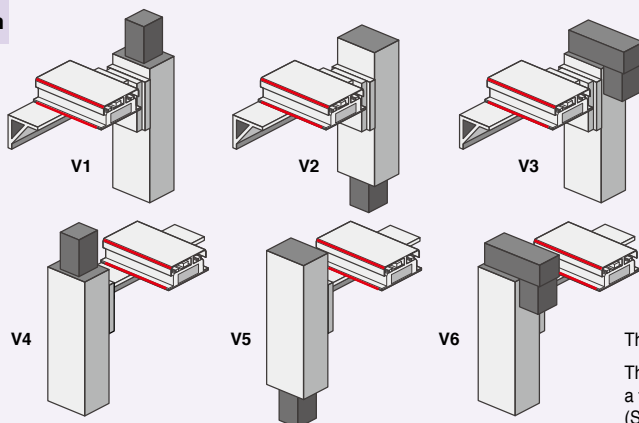

The motor folding is performed only on the top side. The folding direction is only on a side where there is a flexible cable carrier. (Side where the slider is not ejected.)

* All illustrations shown above use the circulation installation position R (right installation).

Circulation unit Basic specifications

JGX16-H (Horizontal circulation) Basic specifications

Axis configuration	Junction axis		LCMR200 ¹
Motor output	□80 / 750W		-
Repeated positioning accuracy	+/-5μm		+/-5μm
Speed reduction mechanism/drive method	Grinding ball screw φ20 (C5 grade)		Linear motor with moving magnet type core
Ball screw lead	40mm	20mm	-
Maximum speed ^{*2}	2400mm/sec	1200mm/sec	2500mm/sec
Circulation pitch/linear module length	200mm ^{*3} to 1350mm (50mm pitch)		200mm, 300mm, 500mm
Position detection	Magnetic type absolute position sensor ⁴		Magnetic type absolute position sensor
Operating temperature	0 °C to 40 °C ⁵		
Controller	YHX controller		

*1: For details about the specifications, see P.24.

*2: The maximum speed may not be reached depending on the operating range.

*3: The cable extraction direction of the forward and backward modules is reversed (outside).

*4: The circulation transfer position only

*5: The operation is performed at an environmental temperature (+/-5 °C) at which the installation and adjustment have been performed.

JGX16-V (Vertical circulation) Basic specifications

Axis configuration	Junction axis		LCMR200 ¹
Motor output	□80 / 750W		-
Repeated positioning accuracy	+/-5μm		+/-5μm
Speed reduction mechanism/drive method	Grinding ball screw φ20 (C5 grade)		Linear motor with moving magnet type core
Ball screw lead	20mm	10mm	-
Maximum speed ^{*2}	1200mm/sec	600mm/sec	2500mm/sec
Circulation pitch/linear module length	300mm to 600mm (50mm pitch)		200mm, 300mm, 500mm
Position detection	Magnetic type absolute position sensor ³		Magnetic type absolute position sensor
Operating temperature	0 °C to 40 °C ⁴		
Controller	YHX controller		

*1: For details about the specifications, see P.24.

*2: The maximum speed may not be reached depending on the operating range.

*3: The circulation transfer position only

*4: The operation is performed at an environmental temperature (+/-5 °C) at which the installation and adjustment have been performed.

For the maximum payload and allowable overhang per robot slider, see page 61.

Minimum circulation pitch of the circulation unit depending on the cable extraction direction

- ① Front cable extraction + rear cable extraction
 <Cable extraction direction is outward.>
 → Select a circulation pitch of 200 mm or more.

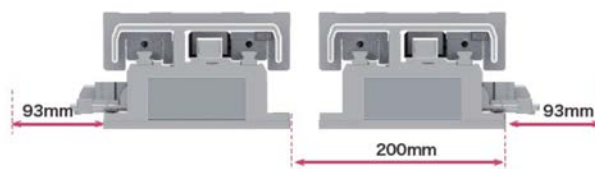

- ② Front cable extraction + front cable extraction
 (Or, rear cable extraction + rear cable extraction)
 <Cable extraction direction is the same orientation.>
 → Select a circulation pitch of 300 mm or more.

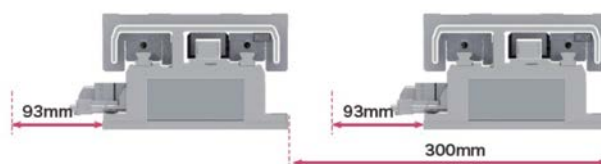

- ③ Rear cable extraction + front cable extraction
 <Cable extraction direction is inward.>
 → Select a circulation pitch of 400 mm or more.



* However, when the cables can be stacked, a circulation pitch of 350 mm is also possible.



Circulation unit External view

Horizontal circulation

JGX16-H1L/H2L

JGX16-H1L

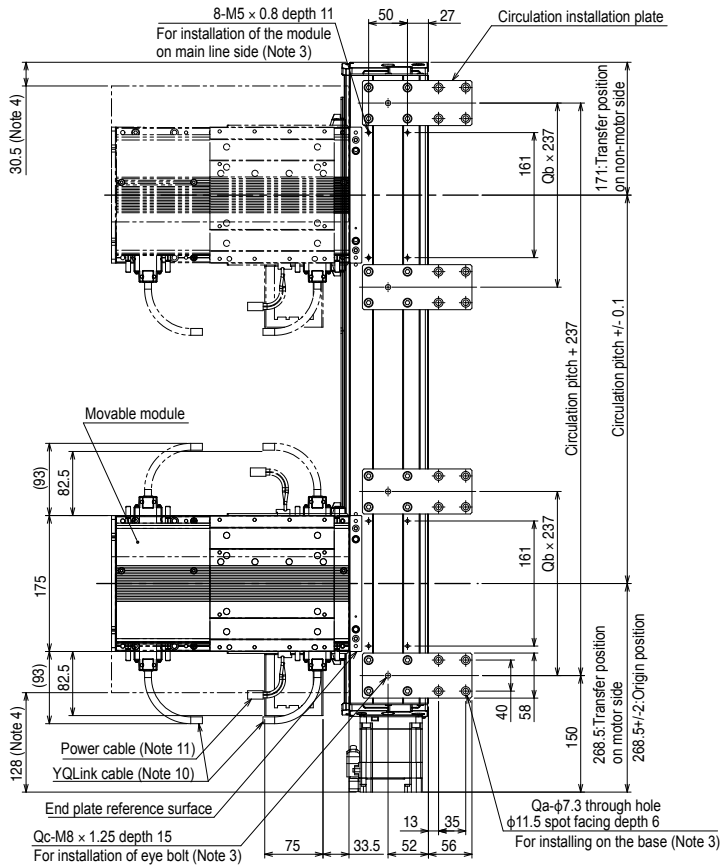

JGX16-H2L

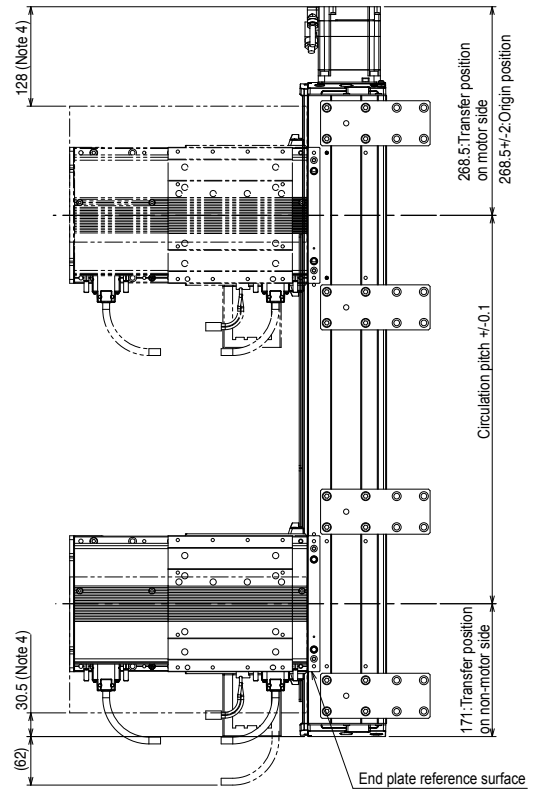

2-slider circulation (Note 6)

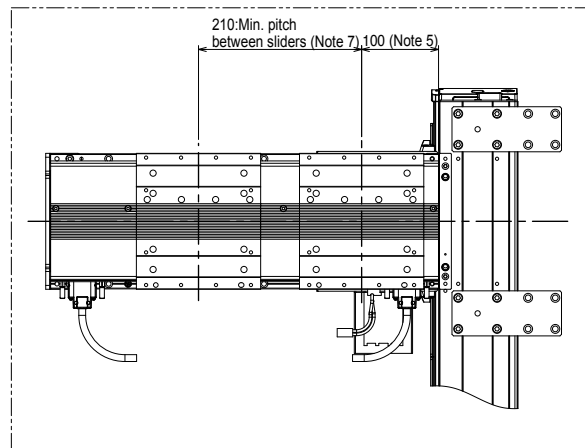
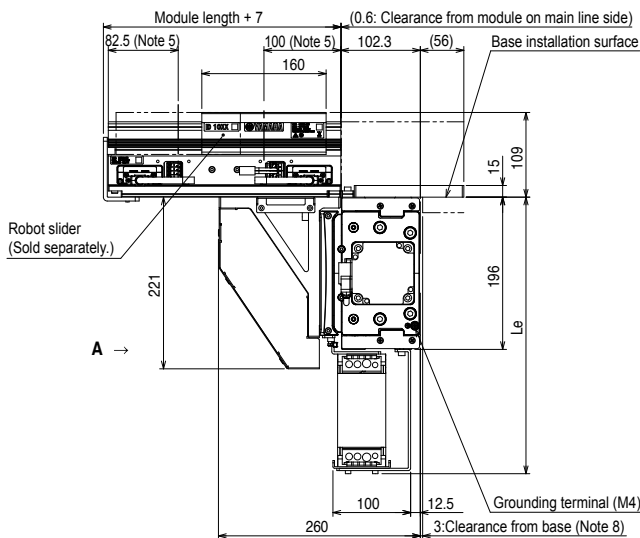

- Note 1. For details about the installation and operation procedures, see the user's manual.
 Note 2. The user wiring cannot be passed through the flexible cable carrier.
 Note 3. Do not use the installation hole at each location for an application other than that specified.
 Note 4. Movable module position when the junction axis is stopped by the mechanical stopper.
 Note 5. Robot slider unstoppage range from the module end.
 An unstoppage range of 100 mm on the main line side may vary depending on the pallet length.
 For details, see the Manual.
 Note 6. Two-slider simultaneous circulation can be performed only when the movable module is 500 mm-module.
 Note 7. When the pallet length is 200 mm or more, this pitch is "pallet length + 10 mm".
 However, when two sliders start at the same time, the minimum pitch is 250 mm or "pallet length + 50 mm".
 Note 8. Reference value for installation of the base. Install the circulation unit so that it is not in contact with the base end.
 Note 9. The robot cable fixing R is R30. The lead-out direction may vary depending on the specifications.
 Note 10. The YQLink cable fixing R is R55. This cable may become the termination connector depending on the specifications.
 Note 11. The power cable fixing R is R55.
 Note 12. The weight of the main body is a reference value. The weights of the module and robot slider are not included.
 Note 13. For the battery-less absolute, a length of 8 mm is added.

Circulation pitch	200	250	300	350	400	450	500	550	600	650	700	750	800	850	900	950	1000	1050	1100	1150	1200	1250	1300	1350		
La	639.5	689.5	739.5	789.5	839.5	889.5	939.5	989.5	1039.5	1089.5	1139.5	1189.5	1239.5	1289.5	1339.5	1389.5	1439.5	1489.5	1539.5	1589.5	1639.5	1689.5	1739.5	1789.5		
Lb	542.5	592.5	642.5	692.5	742.5	792.5	842.5	892.5	942.5	992.5	1042.5	1092.5	1142.5	1192.5	1242.5	1292.5	1342.5	1392.5	1442.5	1492.5	1542.5	1592.5	1642.5	1692.5		
Lc	196.5	253.5	307.5	60.5	85.5	171.5	196.5	251.5	306.5	361.5	416.5	471.5	496.5	553.5	607.5	360.5	385.5	471.5	496.5	551.5	606.5	661.5	716.5	771.5		
Ld	300	300	300	601	601	601	601	601	601	601	601	601	601	601	601	902	902	902	902	902	902	902	902	902		
Le	356	356	356	356	356	356	356	356	356	356	356	356	356	366	366	366	366	366	366	366	366	366	366	366		
Qa	8	8	16	16	16	16	16	16	16	16	16	16	16	16	16	16	16	16	16	16	16	16	16	16		
Qb	0	0	1	1	1	1	1	1	1	1	1	1	1	1	1	1	1	1	1	1	1	1	1	1		
Qc	2	2	4	4	4	4	4	4	4	4	4	4	4	4	4	4	4	4	4	4	4	4	4	4		
Weight (Kg) ^{Note 12}	27.6	28.7	31.7	33.6	34.7	35.8	37	38.1	39.3	40.4	41.6	42.7	43.9	45	46.2	48.1	49.3	50.4	51.6	52.7	53.9	55	56.2	57.3		
Maximum speed (mm/sec)	Lead 40	2400													2160	1920	1680	1440	1320	1200	1080	960	840	720		
	Lead 20	1200													1080	960	840	720	660	600	540	480	420	360		
	Speed setting	-													90%	80%	70%	60%	55%	50%	45%	40%	35%	30%		

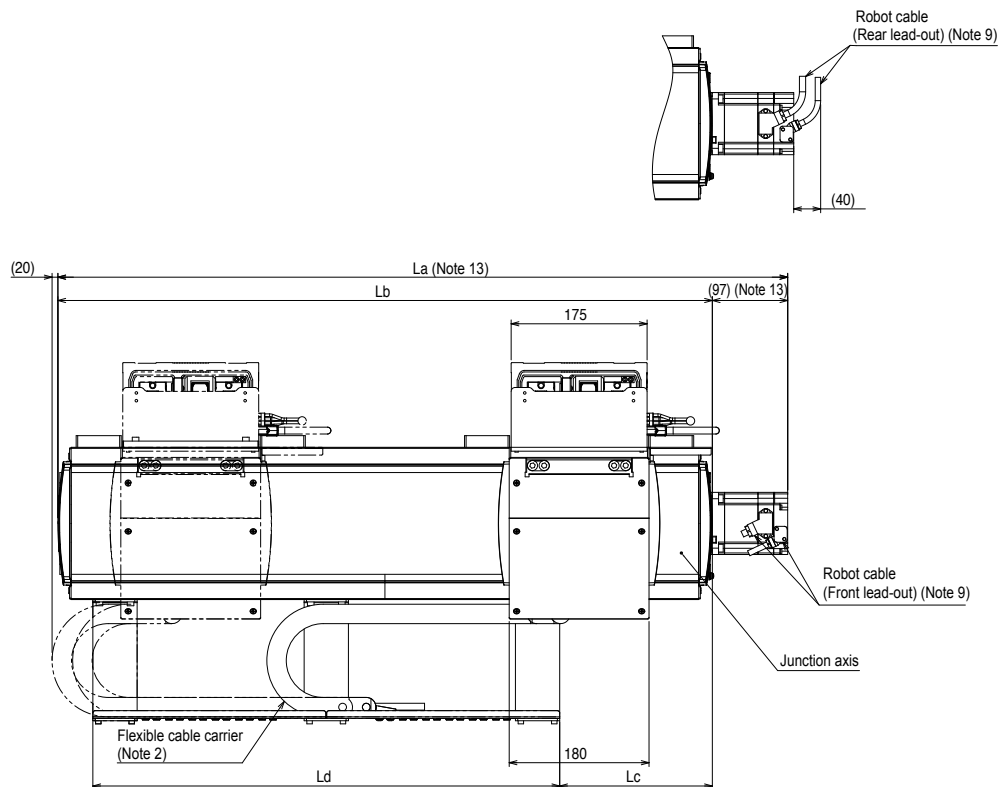

View A

Circulation unit External view

Horizontal circulation

JGX16-H1R/H2R

JGX16-H2R

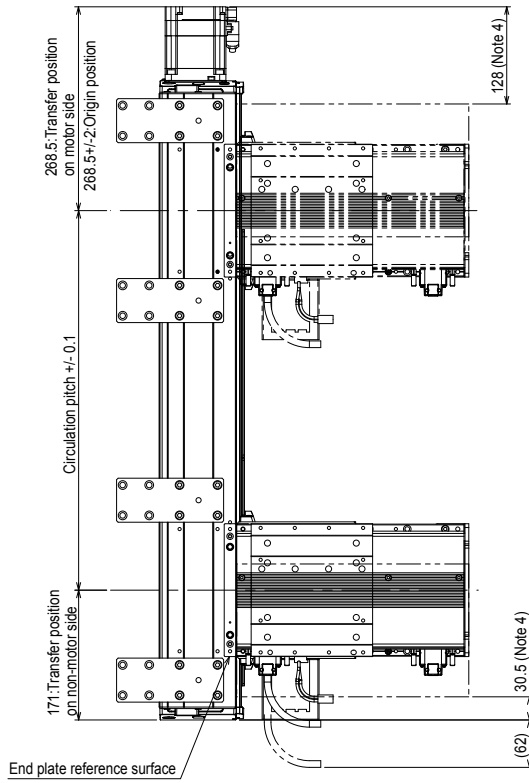

JGX16-H1R

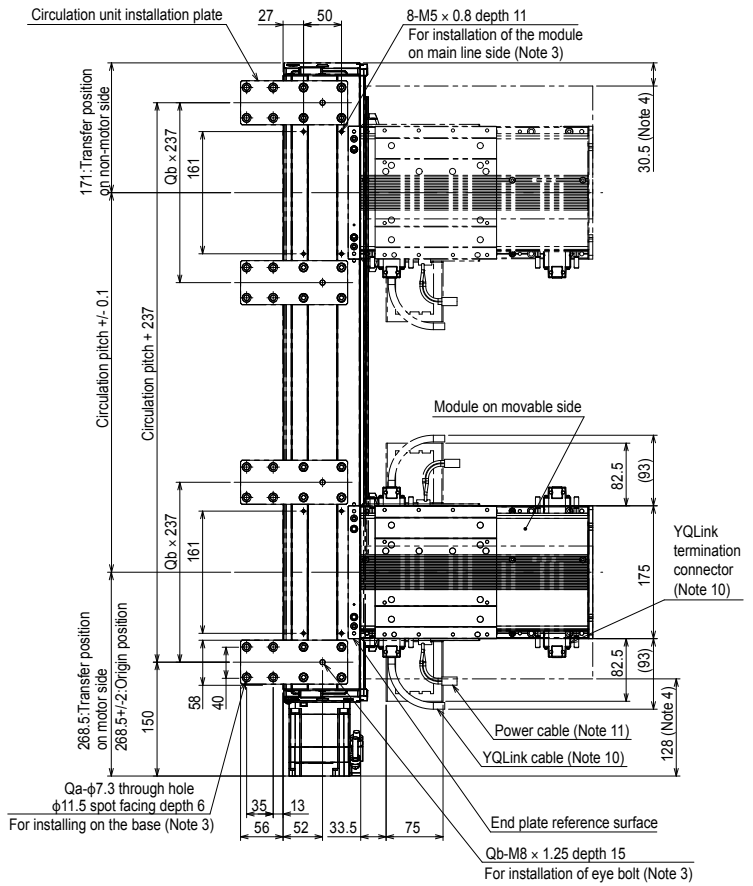

2-slider circulation (Note 6)

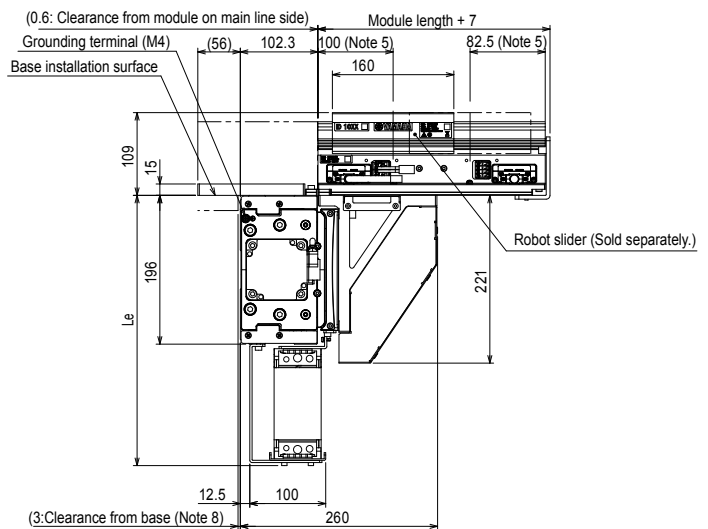
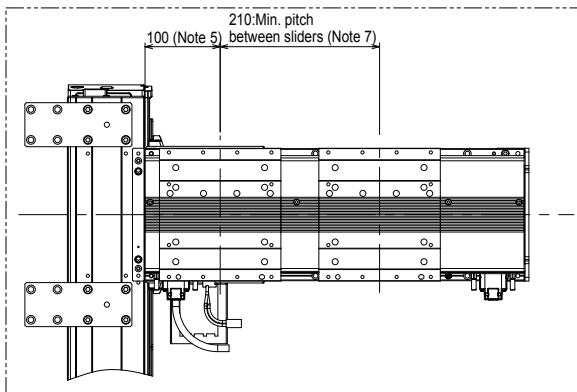

- Note 1. For details about the installation and operation procedures, see the user's manual.
 Note 2. The user wiring cannot be passed through the flexible cable carrier.
 Note 3. Do not use the installation hole at each location for an application other than that specified.
 Note 4. Movable module position when the junction axis is stopped by the mechanical stopper.
 Note 5. Robot slider unstopplable range from the module end.
 An unstopplable range of 100 mm on the main line side may vary depending on the pallet length.
 For details, see the Manual.
 Note 6. Two-slider simultaneous circulation can be performed only when the movable module is 500mm-module.
 Note 7. When the pallet length is 200 mm or more, this pitch is "pallet length + 10 mm".
 However, when two sliders start at the same time, the minimum pitch is 250 mm or "pallet length + 50 mm".
 Note 8. Reference value for installation of the base. Install the circulation unit so that it is not in contact with the base end.
 Note 9. The robot cable fixing R is R30. The lead-out direction may vary depending on the specifications.
 Note 10. The YQLink cable fixing R is R55. This cable may become the termination connector depending on the specifications.
 Note 11. The power cable fixing R is R55.
 Note 12. The weight of the main body is a reference value. The weights of the module and robot slider are not included.
 Note 13. For the battery-less absolute, a length of 8 mm is added.

Circulation pitch	200	250	300	350	400	450	500	550	600	650	700	750	800	850	900	950	1000	1050	1100	1150	1200	1250	1300	1350	
La	639.5	689.5	739.5	789.5	839.5	889.5	939.5	989.5	1039.5	1089.5	1139.5	1189.5	1239.5	1289.5	1339.5	1389.5	1439.5	1489.5	1539.5	1589.5	1639.5	1689.5	1739.5	1789.5	
Lb	542.5	592.5	642.5	692.5	742.5	792.5	842.5	892.5	942.5	992.5	1042.5	1092.5	1142.5	1192.5	1242.5	1292.5	1342.5	1392.5	1442.5	1492.5	1542.5	1592.5	1642.5	1692.5	
Lc	196.5	253.5	307.5	60.5	85.5	171.5	196.5	251.5	306.5	361.5	416.5	471.5	496.5	553.5	607.5	360.5	385.5	471.5	496.5	551.5	606.5	661.5	716.5	771.5	
Ld	300	300	300	601	601	601	601	601	601	601	601	601	601	601	601	902	902	902	902	902	902	902	902	902	
Le	356	356	356	356	356	356	356	356	356	356	356	356	356	356	366	366	366	366	366	366	366	366	366	366	
Qa	8	8	16	16	16	16	16	16	16	16	16	16	16	16	16	16	16	16	16	16	16	16	16	16	
Qb	0	0	1	1	1	1	1	1	1	1	1	1	1	1	1	1	1	1	1	1	1	1	1	1	
Qc	2	2	4	4	4	4	4	4	4	4	4	4	4	4	4	4	4	4	4	4	4	4	4	4	
Weight (Kg) ^{Note 12}	27.6	28.7	31.7	33.6	34.7	35.8	37	38.1	39.3	40.4	41.6	42.7	43.9	45	46.2	48.1	49.3	50.4	51.6	52.7	53.9	55	56.2	57.3	
Maximum speed (mm/sec)	Lead 40	2400												2160	1920	1680	1440	1320	1200	1080	960	840	720		
	Lead 20	1200												1080	960	840	720	660	600	540	480	420	360		
	Speed setting	-												90%	80%	70%	60%	55%	50%	45%	40%	35%	30%		

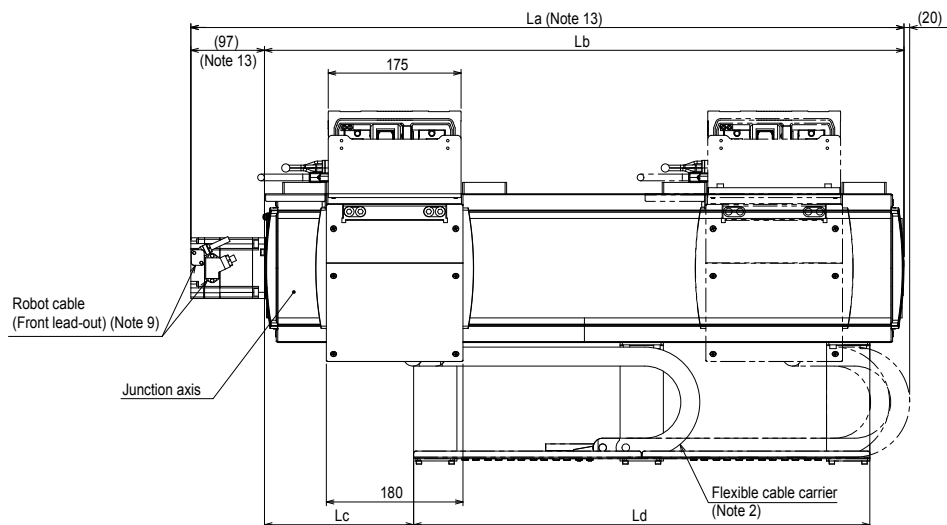
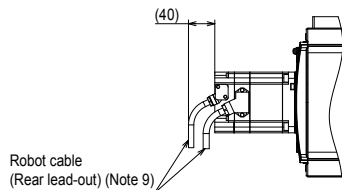

2-slider circulation (Note 15)

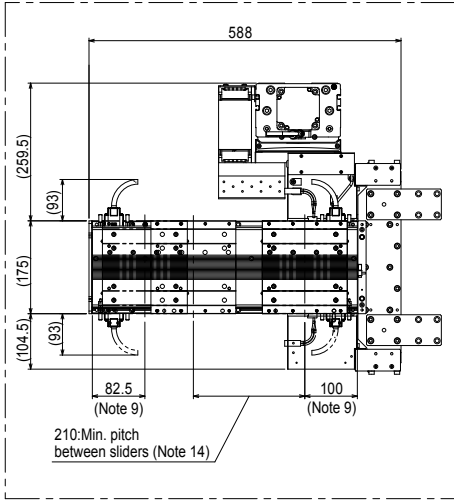

JGX16-V1L

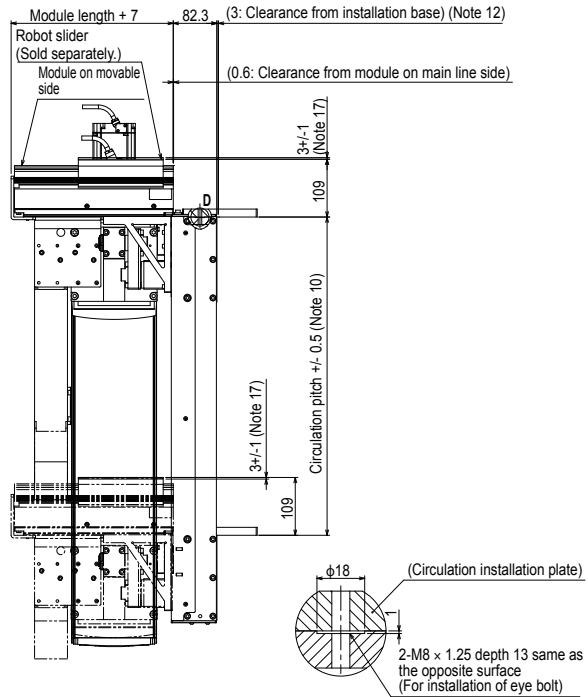
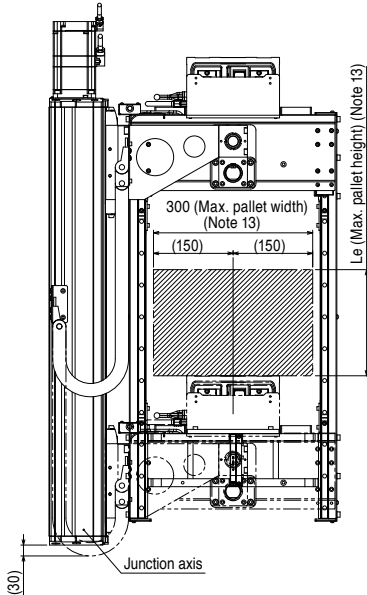
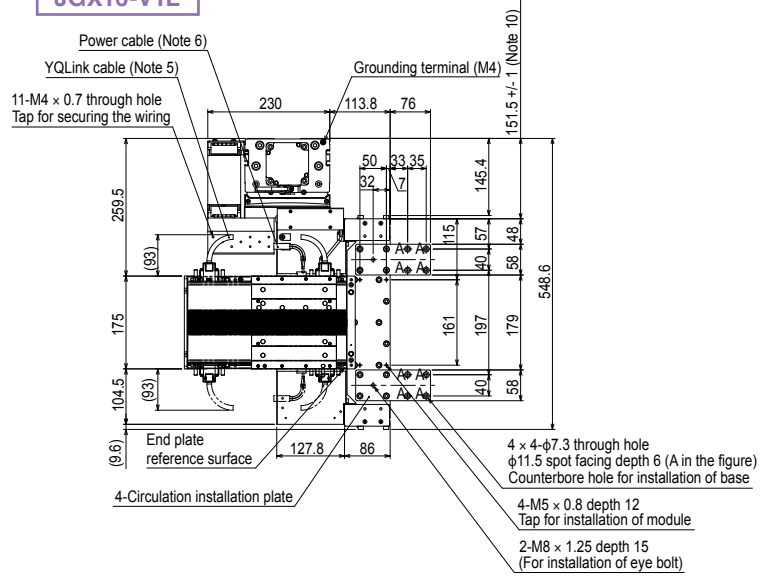

Detailed drawing D

- Note 12. Reference value for installation of the base. Install the circulation unit so that it is not in contact with the base end.
- Note 13. This value may differ from the allowable overhang amount of the robot slider. For details about the payload and allowable overhand amount, see the LCMR200 specifications. Even when the circulation operation is performed with workpieces placed, the dimensions are restricted in the same manner.
- Note 14. When the pallet length is 200 mm or more, this pitch is "pallet length + 10 mm". However, when two sliders start at the same time, the minimum pitch is 250 mm or "pallet length + 50 mm".
- Note 15. Two-slider simultaneous circulation can be performed only when the movable module is 500mm-module.
- Note 16. The origin position is located on the motor side.
- Note 17. Slider top surface position when the junction axis is stopped by the mechanical stopper.

Circulation pitch	300mm	350mm	400mm	450mm	500mm	550mm	600mm
La	421	471	521	571	621	671	721
Lb	467.8	517.8	567.8	617.8	667.8	717.8	767.8
Lc	300	350	400	450	500	550	600
Ld	200	50	100	150	200	50	100
Le	80	130	180	230	280	330	380
Lf	389	439	489	539	589	639	689
Qa	10	12	12	12	12	14	14
Qb	6	8	8	8	8	10	10
Qc	0	1	1	1	1	2	2
Qd	0	1	1	1	1	2	2
Weight (Kg)(Note 7)	47.6	49.0	50.5	52.0	53.5	55.0	56.4

Circulation unit External view

Vertical circulation

JGX16-V4L/V5L/V6L

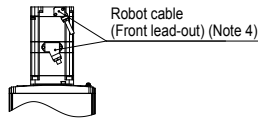

Robot cable
(Front lead-out) (Note 4)

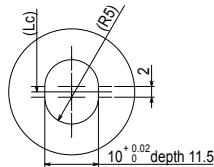

Detailed drawing B

JGX16-V5L

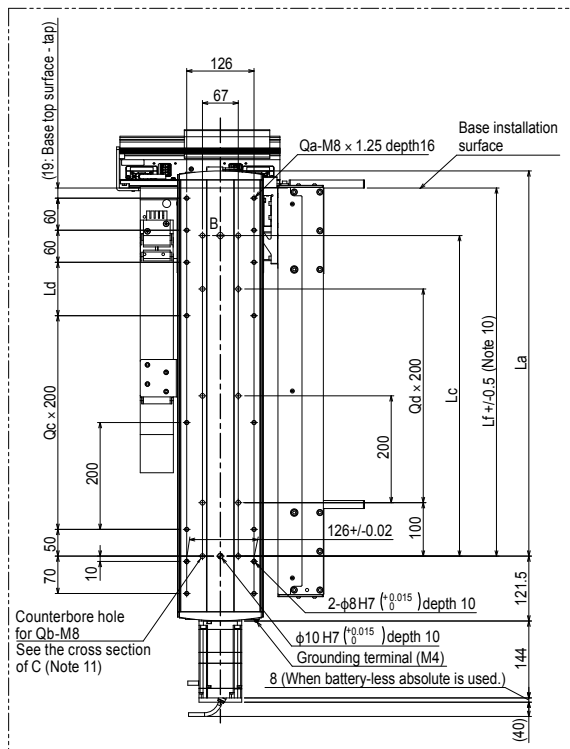

JGX16-V6L

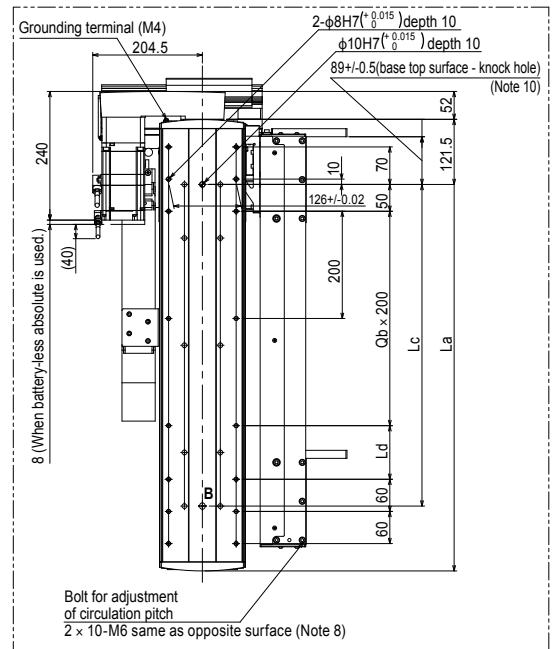

(3: Clearance from installation base) (Note 12) 82.3 Module length + 7
(0.6: Clearance from module on main line side)

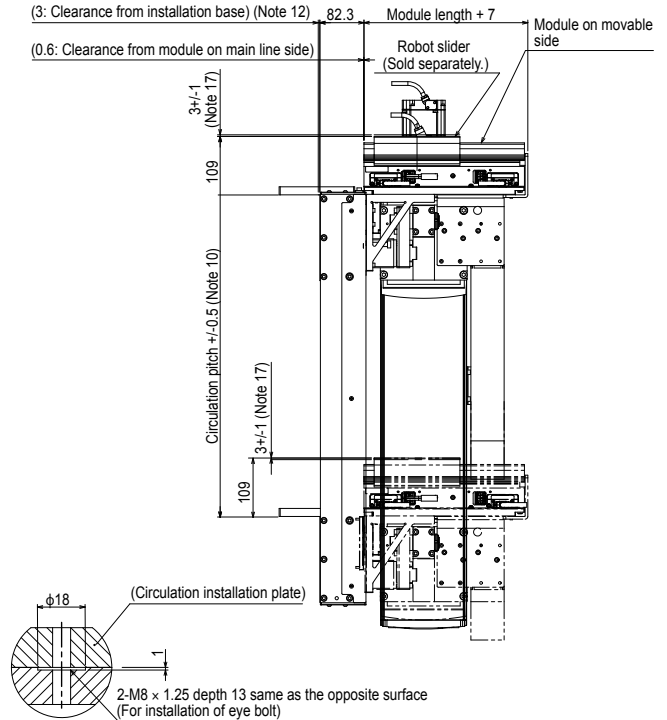

Detailed drawing D

- Note 1. For details about the installation and operation procedures, see the user's manual.
 Note 2. The user wiring cannot be passed through the flexible cable carrier.
 Note 3. Do not use the installation hole at each location for an application other than that specified.
 Note 4. The robot cable fixing R is R30. The lead-out direction may vary depending on the specifications.
 Note 5. The YQLink cable fixing R is R55. This cable may become the termination connector depending on the specifications.
 Note 6. The power cable fixing R is R55.
 Note 7. The weight of the main body is a reference value. The weights of the module and robot slider are not included.
 Note 8. Hexagon socket head cap bolt for fine adjustment of circulation pitch. Maintain a work space where you can access the bolt.
 Note 9. Robot slider unstoppage range from the module end.
 An unstoppage range of 100 mm on the main line side may vary depending on the pallet length. For details, see the manual.

- Note 10. Design and install the base so that it is within the described tolerance.
 Note 11. When securing the unit using the installation counterbore hole (cross section of C), peel off the dust-proof seal adhered to the inside of the axis, and then install the unit.
 Note 12. Reference value for installation of the base. Install the circulation unit so that it is not in contact with the base end.
 Note 13. This value may differ from the allowable overhang amount of the robot slider. For details about the payload and allowable overhang amount, see the LCMR200 specifications. Even when the circulation operation is performed with workpieces placed, the dimensions are restricted in the same manner.
 Note 14. When the pallet length is 200 mm or more, this pitch is "pallet length + 10 mm". However, when two sliders start at the same time, the minimum pitch is 250 mm or "pallet length + 50 mm".
 Note 15. Two-slider simultaneous circulation can be performed only when the movable module is 500mm-module.
 Note 16. The origin position is located on the motor side.
 Note 17. Slider top surface position when the junction axis is stopped by the mechanical stopper.

2-slider circulation (Note 15)

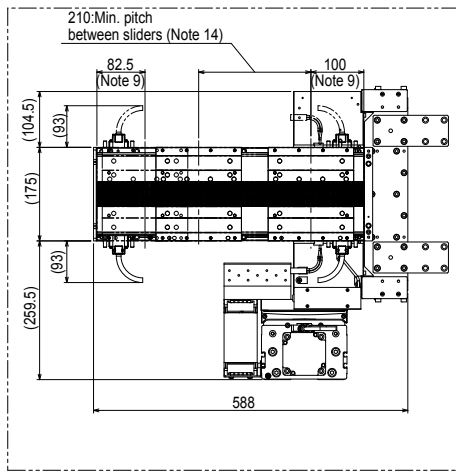

JGX16-V4L

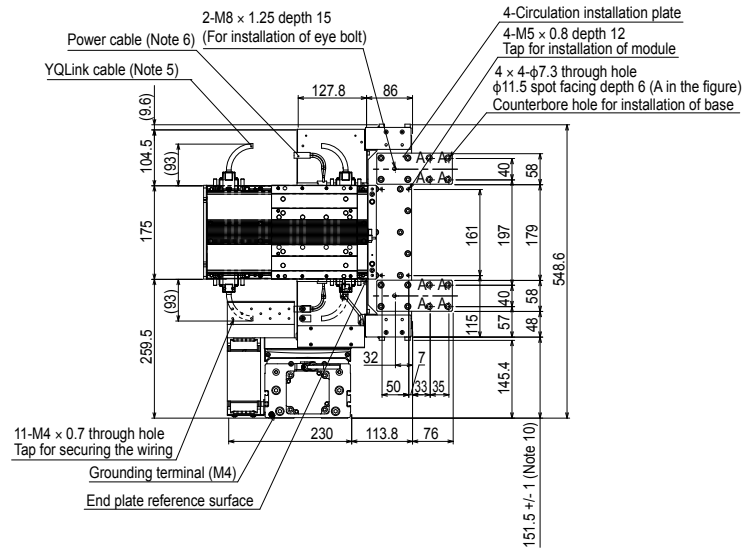

Le(Max. pallet height) (Note 13)

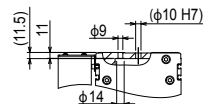
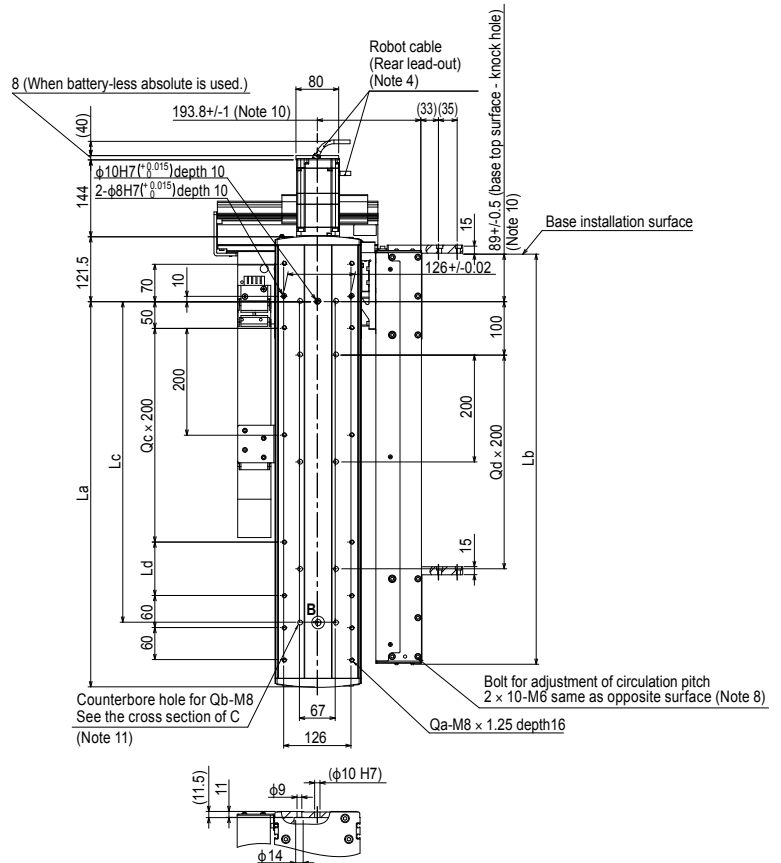
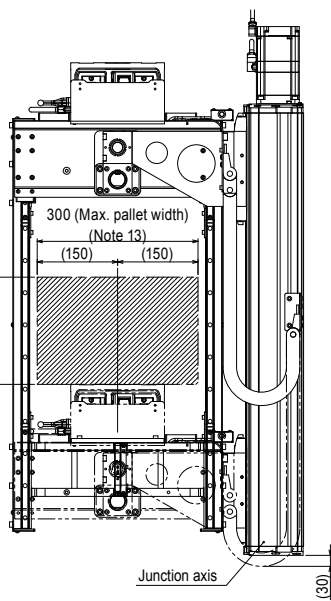

Cross section of C

Circulation pitch	300mm	350mm	400mm	450mm	500mm	550mm	600mm
La	421	471	521	571	621	671	721
Lb	467.8	517.8	567.8	617.8	667.8	717.8	767.8
Lc	300	350	400	450	500	550	600
Ld	200	50	100	150	200	50	100
Le	80	130	180	230	280	330	380
Lf	389	439	489	539	589	639	689
Qa	10	12	12	12	12	14	14
Qb	6	8	8	8	8	10	10
Qc	0	1	1	1	1	2	2
Qd	0	1	1	1	1	2	2
Weight (Kg) (Note 7)	47.6	49.0	50.5	52.0	53.5	55.0	56.4

Circulation unit External view

Vertical circulation

JGX16-V1R/V2R/V3R

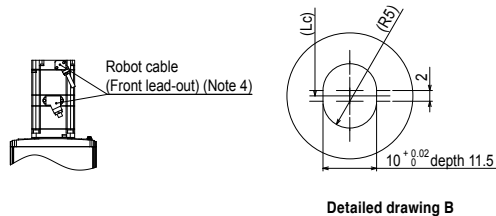

JGX16-V1R

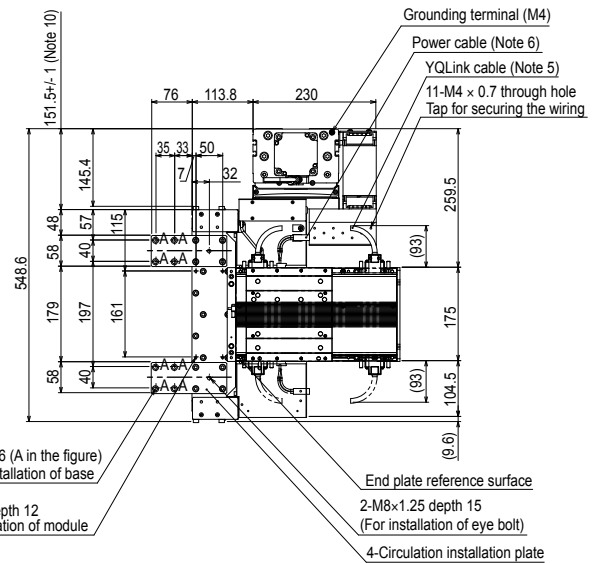

JGX16-V2R

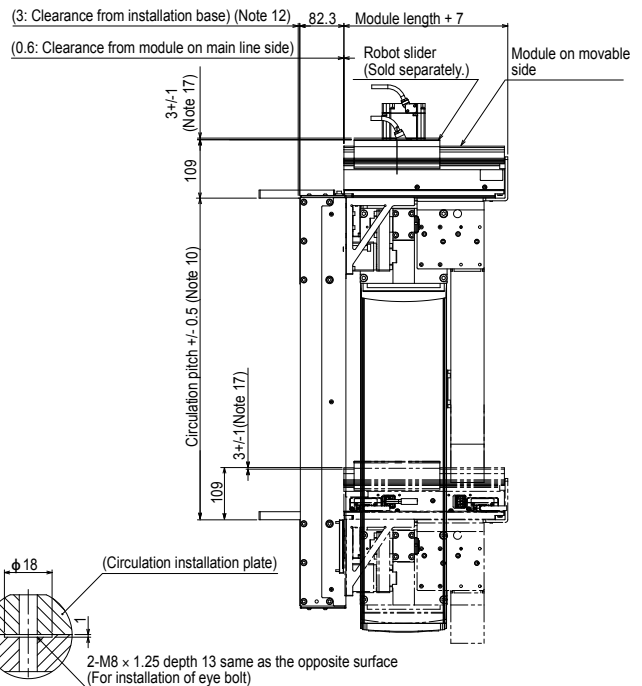
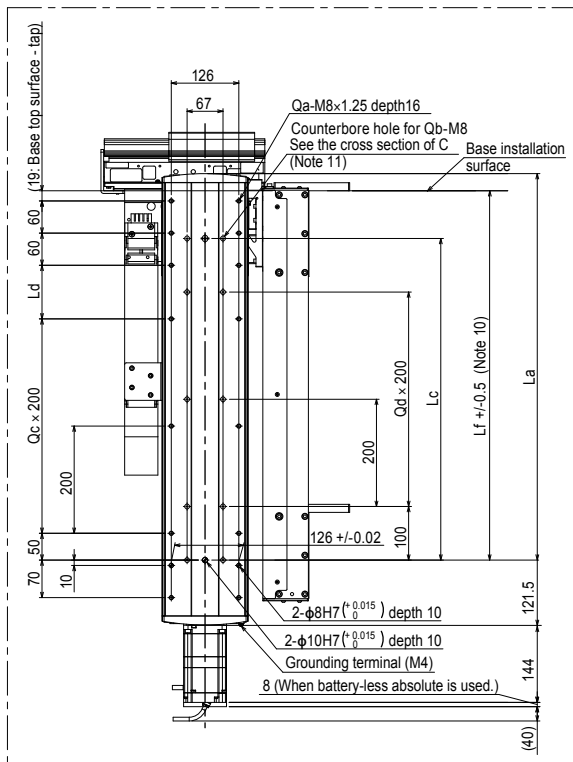

Detailed drawing D

- Note 1. For details about the installation and operation procedures, see the user's manual.
- Note 2. The user wiring cannot be passed through the flexible cable carrier. direction may vary depending on the specifications.
- Note 5. The YQLink cable fixing R is R55. This cable may become the termination connector depending on the specifications.
- Note 6. The power cable fixing R is R55.
- Note 7. The weight of the main body is a reference value. The weights of the module and robot slider are not included.
- Note 8. Hexagon socket head cap bolt for fine adjustment of circulation pitch. Maintain a work space where you can access the bolt.
- Note 9. Robot slider unstoppage range from the module end. An unstoppage range of 100 mm on the main line side may vary depending on the pallet length. For details, see the manual.
- Note 10. Design and install the base so that it is within the described tolerance.

- Note 11. When securing the unit using the installation counterbore hole (cross section of C), peel off the dust-proof seal adhered to the inside of the axis, and then install the unit.
- Note 12. Reference value for installation of the base. Install the circulation unit so that it is not in contact with the base end.
- Note 13. This value may differ from the allowable overhang amount of the robot slider. For details about the payload and allowable overhang amount, see the LCMR200 specifications. Even when the circulation operation is performed with workpieces placed, the dimensions are restricted in the same manner.
- Note 14. When the pallet length is 200 mm or more, this pitch is "pallet length + 10 mm". However, when two sliders start at the same time, the minimum pitch is 250 mm or "pallet length + 50 mm".
- Note 15. Two-slider simultaneous circulation can be performed only when the movable module is 500mm-module.
- Note 16. The origin position is located on the motor side.
- Note 17. Slider top surface position when the junction axis is stopped by the mechanical stopper.

2-slider circulation (Note 15)

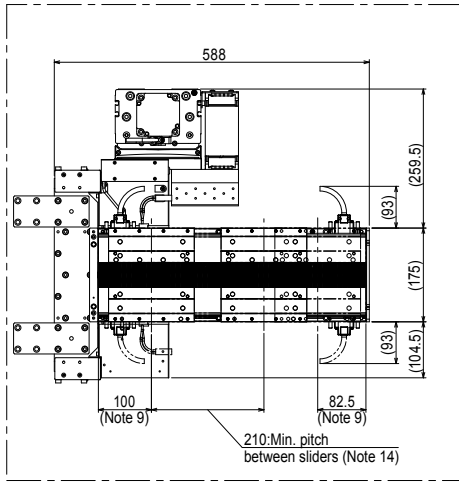

JGX16-V3R

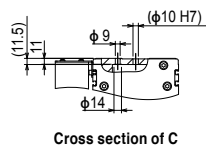
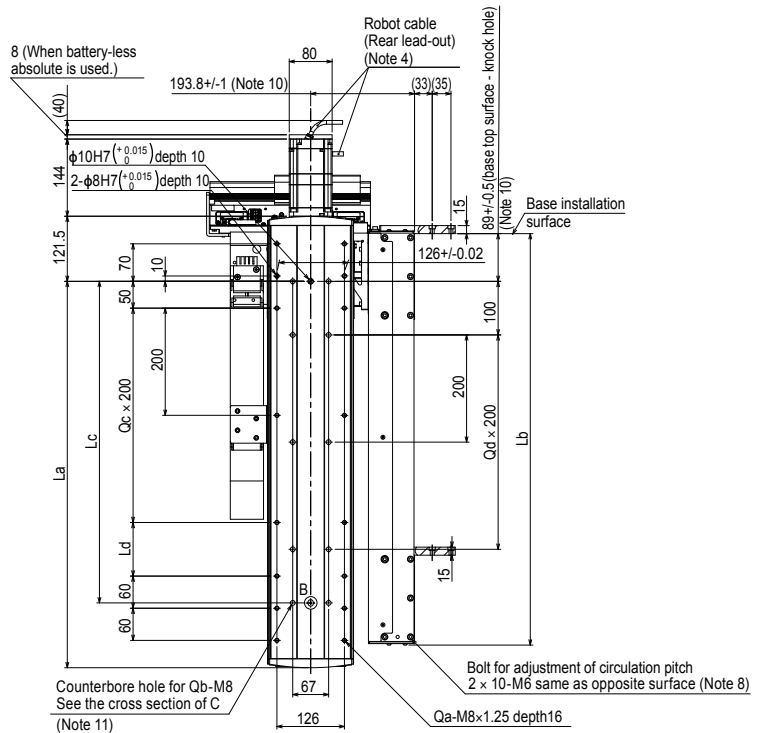
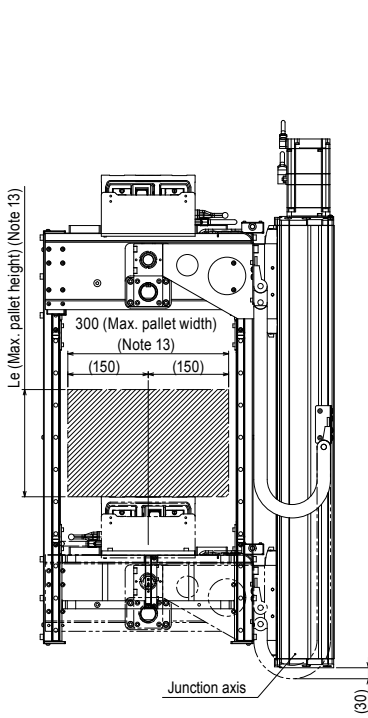
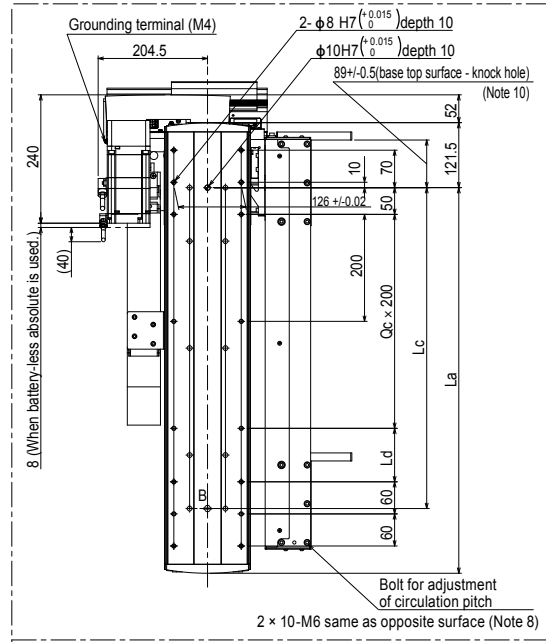

Cross section of C

Circulation pitch	300mm	350mm	400mm	450mm	500mm	550mm	600mm
La	421	471	521	571	621	671	721
Lb	467.8	517.8	567.8	617.8	667.8	717.8	767.8
Lc	300	350	400	450	500	550	600
Ld	200	50	100	150	200	50	100
Le	80	130	180	230	280	330	380
Lf	389	439	489	539	589	639	689
Qa	10	12	12	12	12	14	14
Qb	6	8	8	8	8	10	10
Qc	0	1	1	1	1	2	2
Qd	0	1	1	1	1	2	2
Weight (Kg)(Note 7)	47.6	49.0	50.5	52.0	53.5	55.0	56.4

Circulation unit External view

Vertical circulation

JGX16-V4R/V5R/V6R

JGX16-V4R

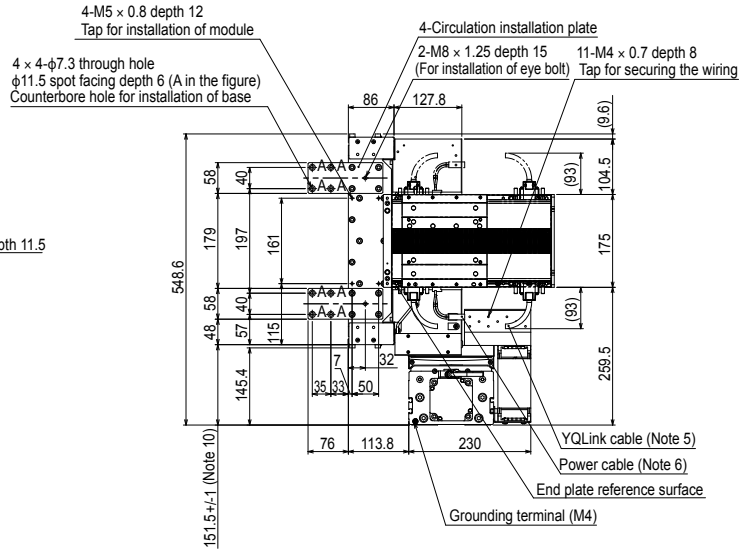

Robot cable (Front lead-out) (Note 4)

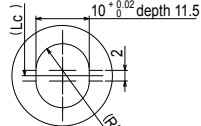
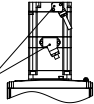

Detailed drawing B

JGX16-V5R

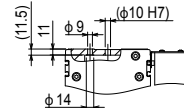
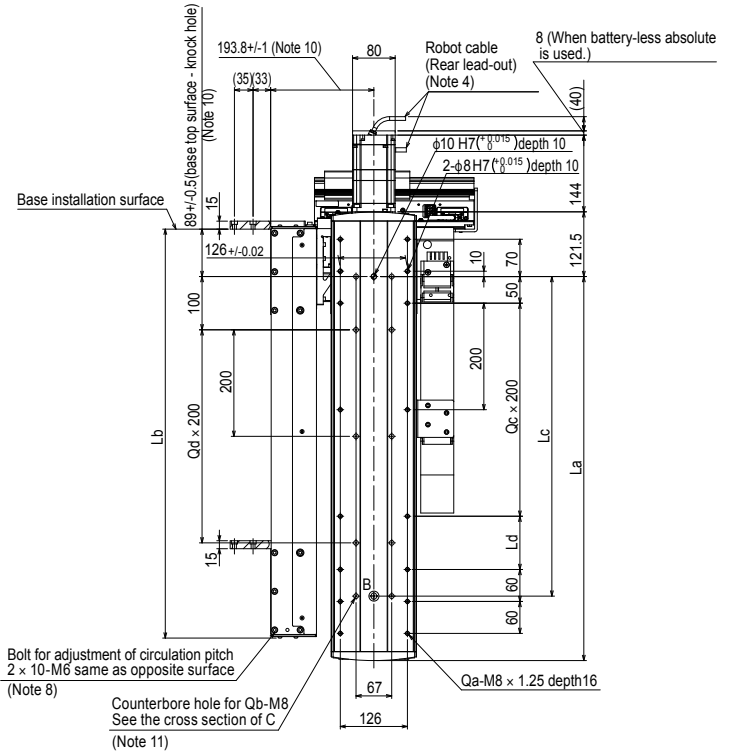
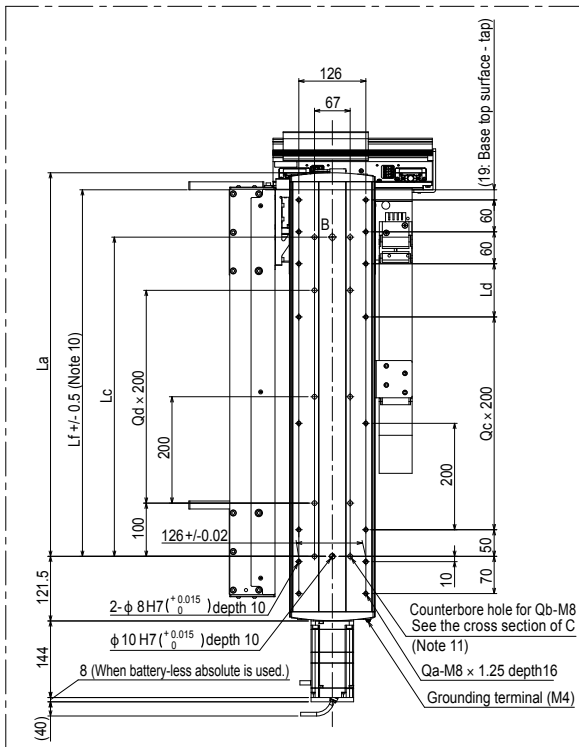

Cross section of C

- Note 1. For details about the installation and operation procedures, see the user's manual.
- Note 2. The user wiring cannot be passed through the flexible cable carrier.
- Note 3. Do not use the installation hole at each location for an application other than that specified.
- Note 4. The robot cable fixing R is R30. The lead-out direction may vary depending on the specifications.
- Note 5. The YQLink cable fixing R is R55. This cable may become the termination connector depending on the specifications.
- Note 6. The power cable fixing R is R55.
- Note 7. The weight of the main body is a reference value. The weights of the module and robot slider are not included.

- Note 8. Hexagon socket head cap bolt for fine adjustment of circulation pitch. Maintain a work space where you can access the bolt.
- Note 9. Robot slider unstoppage range from the module end. An unstoppage range of 100 mm on the main line side may vary depending on the pallet length. For details, see the manual.
- Note 10. Design and install the base so that it is within the described tolerance.
- Note 11. When securing the unit using the installation counterbore hole (cross section of C), peel off the dust-proof seal adhered to the inside of the axis, and then install the unit.
- Note 12. Reference value for installation of the base. Install the circulation unit so that it is not in contact with the base end.

2-slider circulation (Note 15)

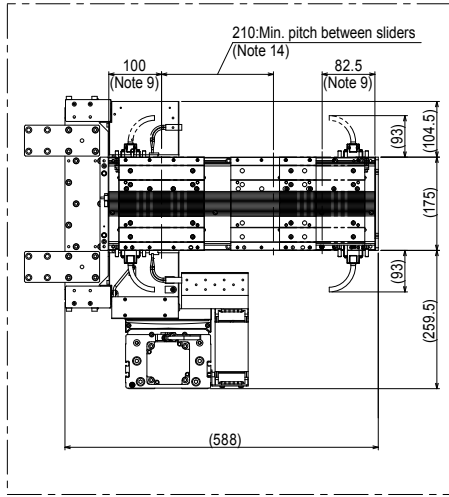

JGX16-V6R

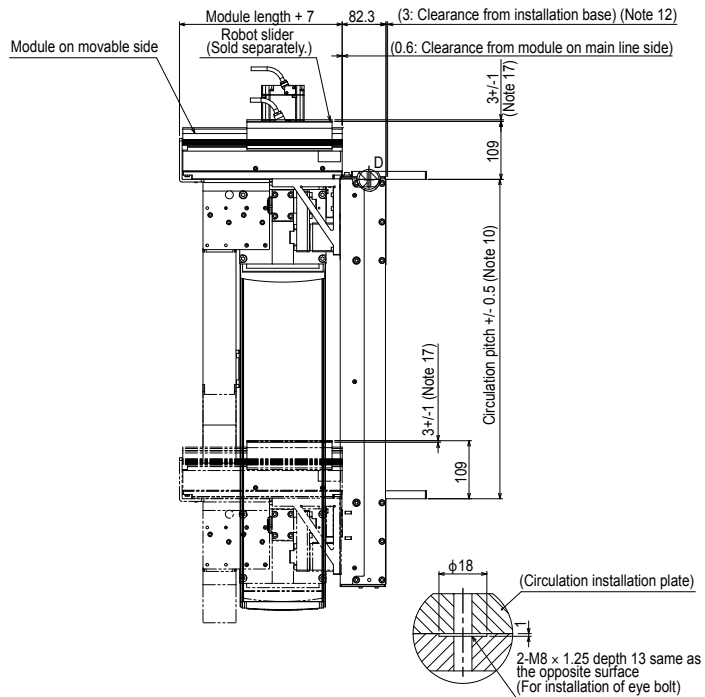
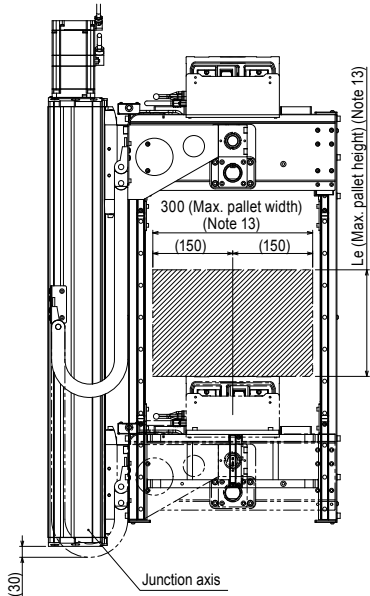
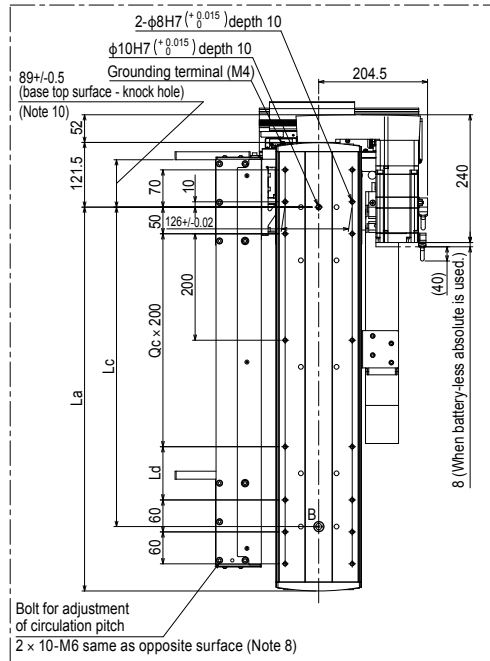

Detailed drawing D

- Note 13. This value may differ from the allowable overhang amount of the robot slider. For details about the payload and allowable overhang amount, see the LCMR200 specifications. Even when the circulation operation is performed with workpieces placed, the dimensions are restricted in the same manner.
- Note 14. When the pallet length is 200 mm or more, this pitch is "pallet length + 10 mm". However, when two sliders start at the same time, the minimum pitch is 250 mm or "pallet length + 50 mm".
- Note 15. Two-slider simultaneous circulation can be performed only when the movable module is 500mm-module.
- Note 16. The origin position is located on the motor side.
- Note 17. Slider top surface position when the junction axis is stopped by the mechanical stopper.

Circulation pitch	300mm	350mm	400mm	450mm	500mm	550mm	600mm
La	421	471	521	571	621	671	721
Lb	467.8	517.8	567.8	617.8	667.8	717.8	767.8
Lc	300	350	400	450	500	550	600
Ld	200	50	100	150	200	50	100
Le	80	130	180	230	280	330	380
Lf	389	439	489	539	589	639	689
Qa	10	12	12	12	12	14	14
Qb	6	8	8	8	8	10	10
Qc	0	1	1	1	1	2	2
Qd	0	1	1	1	1	2	2
Weight (Kg)(Note 7)	47.6	49.0	50.5	52.0	53.5	55.0	56.4

LCMR200 Features
 Circulation unit Features
 Traversing unit Features
 YHX Features
 LCMR200 Specifications
 Circulation unit Specifications
 Traversing unit specifications
 JG/Y accuracy measurement jig
 Others
 YHX Specifications

Traversing unit Order model

Traversing unit (A)2-row branching specifications / (B)3-row branching specifications

JGX16

Axis main body	Combination ①	Lead designation	Single-axis motor specification	Traverse pitch ② ¹	Intermediate pitch ② ²
	H1T: Left of junction axis/Front of motor H2T: Left of junction axis/Rear of motor H3T: Right of junction axis/Front of motor H4T: Right of junction axis/Rear of motor	40: Lead 40mm 20: Lead 20mm	Blank: Battery-less absolute S: Standard specification	20 to 135cm (5cm pitch)	25 to 110cm (5cm pitch)

Left fixed module installation position - Right fixed module installation position ③ ²		Robot cable length	Robot cable lead-out direction
AC-D	ABC-D	R3: 3m R5: 5m R10: 10m	F: Front of motor R: Rear of motor
AC-F	ABC-E		
A-DF	ABC-F		
C-DF	A-DEF		
AC-E	B-DEF		
B-DF	C-DEF		

LCMR200

LCM main body	Variation	YQLink cable length (IN side) ④	YQLink cable length (OUT side) ④
	F2/F3/F5 B2/B3/B5	3: 3m 7: 7m A: 10m	3: 3m 7: 7m A: 10m T: Termination connector

A30

N

Driver	Brake unit	Battery ⁴
A30: YHX-A30-SET	N: None	B: With battery N: None

- *1 When the intermediate pitch is used, the traverse pitch is 50 to 135 cm.
- *2 This pitch is selected only when the intermediate pitch is used. It is necessary that "traverse pitch - intermediate pitch" ≥ 25 cm.
- *3 There are restrictions on the combination of positions where the fixed module is installed. The fixed module cannot be installed at a position other than the selected combination. For details, check "Selectable combination of fixed module installation positions" on page 45.
- *4 When the battery-less absolute is selected, no battery is needed.

Traversing unit (C)Retracting specifications = Fixed module installation position "B-E"

JGX16

Axis main body	Combination ①	Lead designation	Single-axis motor specification	Traverse pitch ②	Intermediate pitch ② ¹
	H1T: Left of junction axis/Front of motor H2T: Left of junction axis/Rear of motor H3T: Right of junction axis/Front of motor H4T: Right of junction axis/Rear of motor	40: Lead 40mm 20: Lead 20mm	Blank: Battery-less absolute S: Standard specification	50 to 130cm (10cm pitch)	25 to 65cm (5cm pitch)

Left fixed module installation position - Right fixed module installation position ③ ²		Robot cable length	Robot cable lead-out direction
B-E		R3: 3m R5: 5m R10: 10m	F: Front of motor R: Rear of motor

LCMR200

LCM main body	Variation	YQLink cable length (IN side) ④	2nd module variation ④ ³	YQLink cable length (OUT side) ④
	F2/F3/F5 B2/B3/B5	3: 3m 7: 7m A: 10m	F2/F3/F5 B2/B3/B5	3: 3m 7: 7m A: 10m T: Termination connector

A30

N

Driver	Brake unit	Battery ⁴
A30: YHX-A30-SET	N: None	B: With battery N: None

- *1 It is necessary that traverse pitch = intermediate pitch x 2.
- *2 For details, check "Selectable combination of fixed module installation positions" on page 45.
- *3 Specify two modules with the same length.
- *4 When the battery-less absolute is selected, no battery is needed.

A 2-row branching specifications

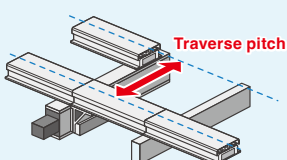

B 3-row branching specifications

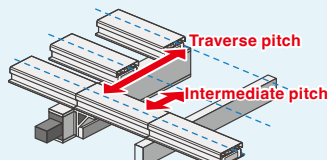

C Retracting specifications

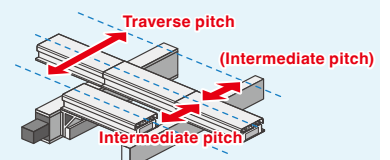

* For the retracting specifications, the intermediate pitch is the same on the front and rear.

Left/right and front/rear are based on when the front line of the module is placed on the front.



1 Combination

H1T: Left of junction axis/Front of motor

H2T: Left of junction axis/Rear of motor

H3T: Right of junction axis/Front of motor

H4T: Right of junction axis/Rear of motor

2 Traverse pitch

3 Intermediate pitch

4 Fixed module installation position

5 Length of YQLink cable

<1 module>

IN side OUT side

<2 module>

IN side OUT side

When the front line is placed on the front, the left side is the IN side while the right side is the OUT side.

6 2nd module variation

2nd module (Rear side when the front line is seen on the front.)

Traversing unit Basic specifications

JGX16-T Basic specifications

Axis configuration	Junction axis		LCMR200 ¹
Motor output	□80 / 750W		-
Repeated positioning accuracy	+/-5µm		+/-5µm
Speed reduction mechanism/drive method	Grinding ball screw φ20 (C5 grade)		Linear motor with moving magnet type core
Ball screw lead	40mm	20mm	-
Maximum speed ²	2400mm/sec	1200mm/sec	2500mm/sec
Traverse pitch/linear module length	200 to 1350mm (50mm pitch)		200, 300, 500
Position detection	Magnetic type absolute position sensor ³		Magnetic type absolute position sensor
Operating temperature	0°C to 40°C ⁴		
Controller	YHX controller		

*1: For details about the specifications, see P.24.
 *2: The maximum speed may not be reached depending on the operating range.
 *3: Slider transfer position only
 *4: The operation is performed at an environmental temperature (+/-5 °C) at which the installation and adjustment have been performed.

For the maximum payload and allowable overhang per robot slider, see page 61.

Selectable combination of fixed module installation positions

2-row branching specifications

Selectable combination

- AC-D
- AC-F
- A-DF
- C-DF

3-row branching specifications

Selectable combination

- ABC-D
- ABC-E
- ABC-F
- A-DEF
- B-DEF
- C-DEF
- AC-E
- B-DF

Retracting specifications

Selectable combination

- B-E

B-E (2-module traverse)

LCMR200 Features
 Circulation unit Features
 Traversing unit features
 YHX Features
 LCMR200 Specifications
 Circulation unit Specifications
 Traversing unit specifications
 JG16 accuracy measurement jig
 Others
 YHX Specifications

Traversing unit External view

2-row branching specifications

JGX16-H1T/H2T

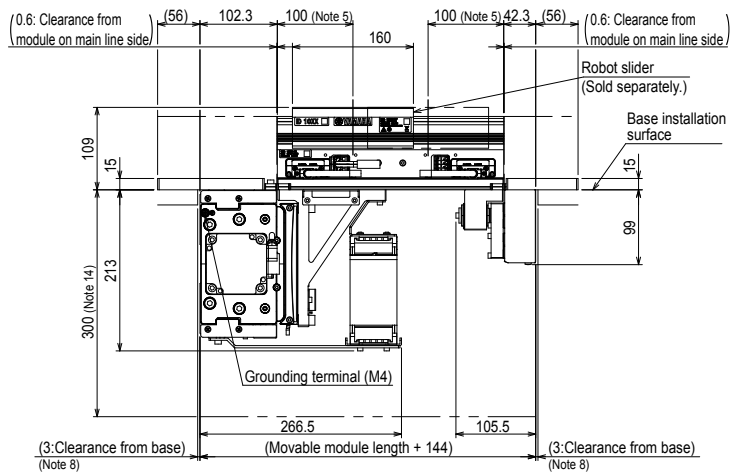
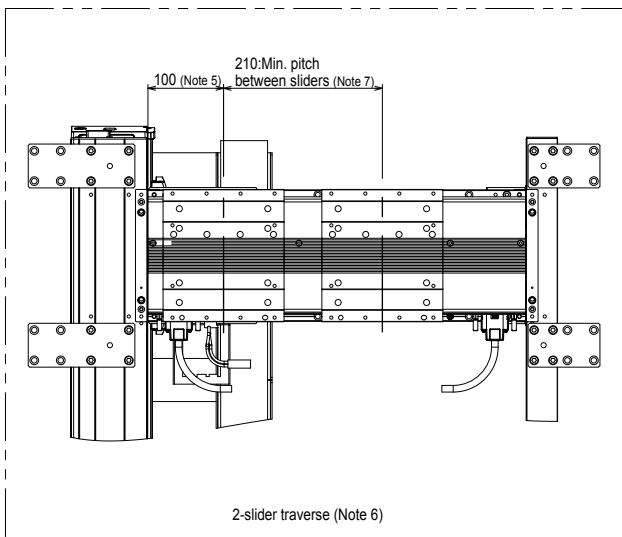
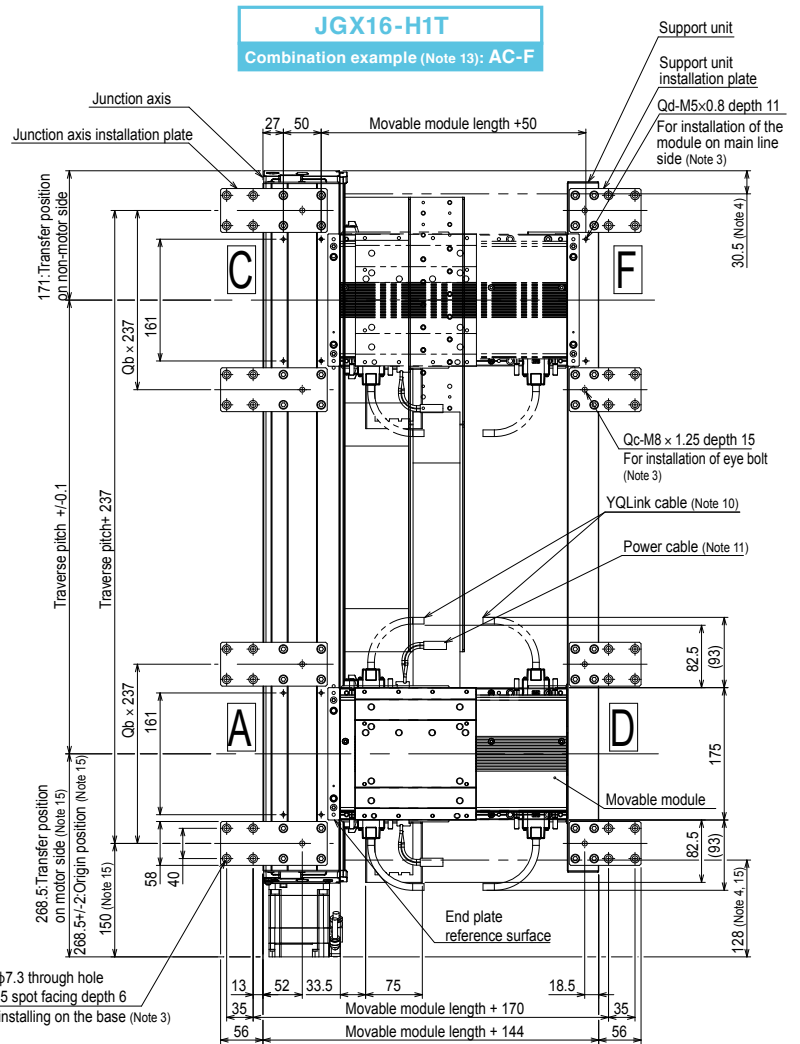
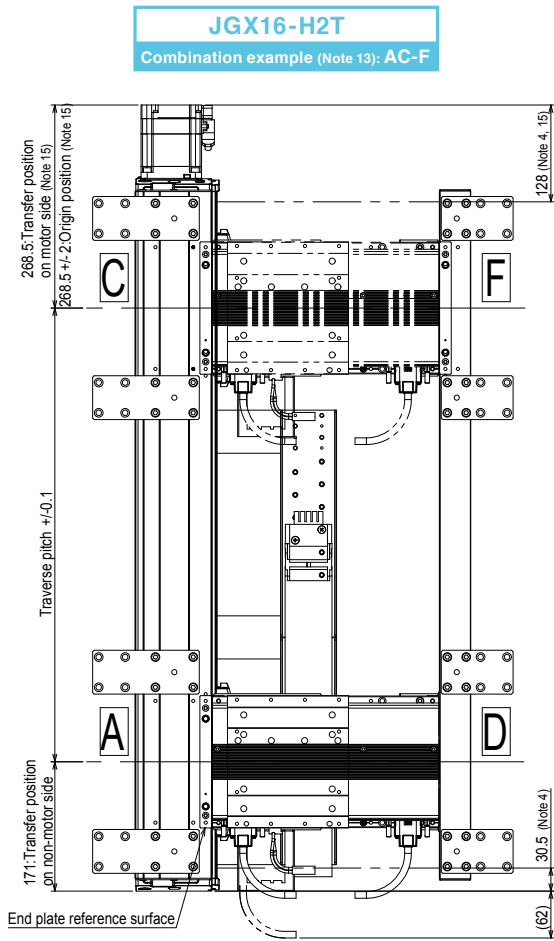

- Note 1. For details about the installation and operation procedures, see the user's manual.
 Note 2. The user wiring cannot be passed through the flexible cable carrier.
 Note 3. Do not use the installation hole at each location for an application other than that specified.
 Note 4. Movable module position when the junction axis is stopped by the mechanical stopper.
 Note 5. Robot slider unstoppage range from the module end.
 An unstoppage range of 100 mm may vary depending on the pallet length.
 For details, see the YHX User's Manual.
 Note 6. 2-slider simultaneous traverse is possible only when the movable module is a 500 mm module.
 Note 7. When the pallet length is 200 mm or more, this pitch is "pallet length + 10 mm".
 However, when two sliders start at the same time, the minimum pitch is 250 mm or "pallet length + 50 mm".
 Note 8. Reference value for installation of the base.
 Perform the installation so that the junction axis and support unit are not in contact with the end face of the installation base.
 Note 9. The robot cable fixing R is R30. The lead-out direction may vary depending on the specifications.
 Note 10. The YQLink cable fixing R is R55. This cable may become the termination connector depending on the specifications.
 Note 11. The power cable fixing R is R55.
 Note 12. The weight of the main body is a reference value. The weights of the module and robot slider are not included.
 Note 13. The module installation position on the main line side can be selected from the following combinations.
 The end plate for positioning the module on the main line side is installed only at the selected combination position.
 The module on the main line side cannot be installed at a position other than the selected combination.
 •AC-D •A-DF
 •AC-F •C-DF
 Note 14. A maintenance space of 300 mm must be maintained below the top surface of the installation base.
 Note 15. For the battery-less absolute, a length of 8 mm is added.

Traverse pitch	200	250	300	350	400	450	500	550	600	650	700	750	800
La	639.5	689.5	739.5	789.5	839.5	889.5	939.5	989.5	1039.5	1089.5	1139.5	1189.5	1239.5
Lb	542.5	592.5	642.5	692.5	742.5	792.5	842.5	892.5	942.5	992.5	1042.5	1092.5	1142.5
Lc	196.5	253.5	307.5	60.5	85.5	171.5	196.5	251.5	306.5	361.5	416.5	471.5	496.5
Ld	300	300	300	601	601	601	601	601	601	601	601	601	601
Qa	16	16	32	32	32	32	32	32	32	32	32	32	32
Qb	0	0	1	1	1	1	1	1	1	1	1	1	1
Qc	4	4	8	8	8	8	8	8	8	8	8	8	8
Weight (Kg)(Note 12)	37.0	38.5	41.8	44.1	45.5	46.9	48.5	49.9	51.5	52.9	54.4	55.9	57.4
Maximum speed (mm/sec)	Lead 40	2400											
	Lead 20	1200											
	Speed setting	-											

Traverse pitch	850	900	950	1000	1050	1100	1150	1200	1250	1300	1350
La	1289.5	1339.5	1389.5	1439.5	1489.5	1539.5	1589.5	1639.5	1689.5	1739.5	1789.5
Lb	1192.5	1242.5	1292.5	1342.5	1392.5	1442.5	1492.5	1542.5	1592.5	1642.5	1692.5
Lc	553.5	607.5	360.5	385.5	471.5	496.5	551.5	606.5	661.5	716.5	771.5
Ld	601	601	902	902	902	902	902	902	902	902	902
Qa	32	32	32	32	32	32	32	32	32	32	32
Qb	1	1	1	1	1	1	1	1	1	1	1
Qc	8	8	8	8	8	8	8	8	8	8	8
Weight (Kg)(Note 12)	58.9	60.4	62.6	64.2	65.6	67.2	68.6	70.1	71.6	73.1	74.6
Maximum speed (mm/sec)	Lead 40	2160	1920	1680	1440	1320	1200	1080	960	840	720
	Lead 20	1080	960	840	720	660	600	540	480	420	360
	Speed setting	90%	80%	70%	60%	55%	50%	45%	40%	35%	30%

Combination	•AC-D •AC-F	•A-DF •C-DF
Qd	10	8

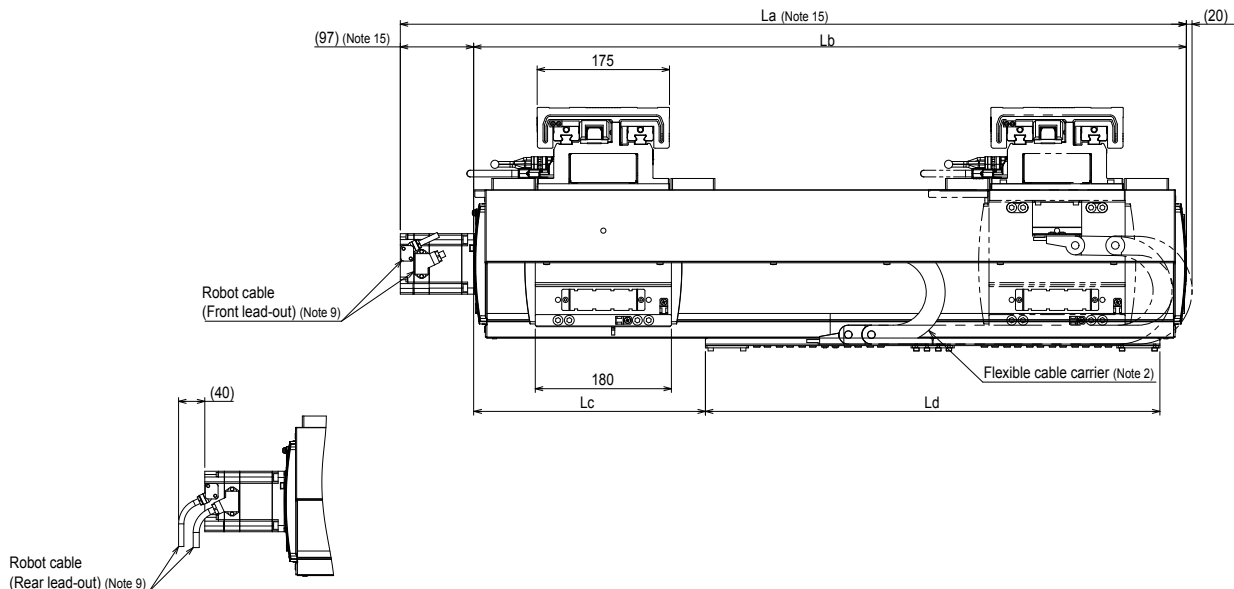

Traversing unit External view

2-row branching specifications

JGX16-H3T/H4T

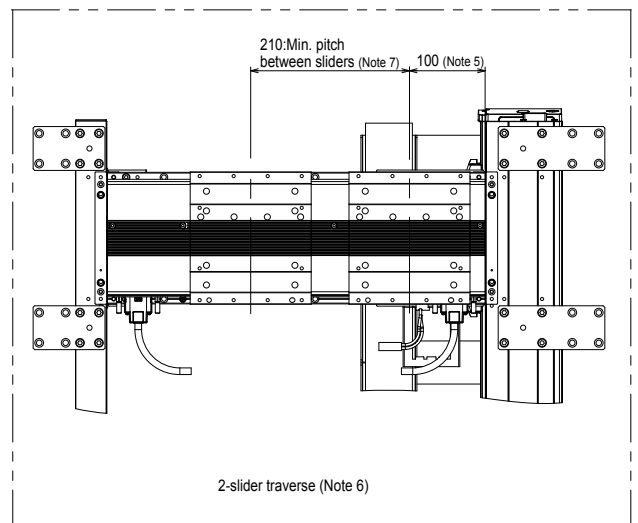
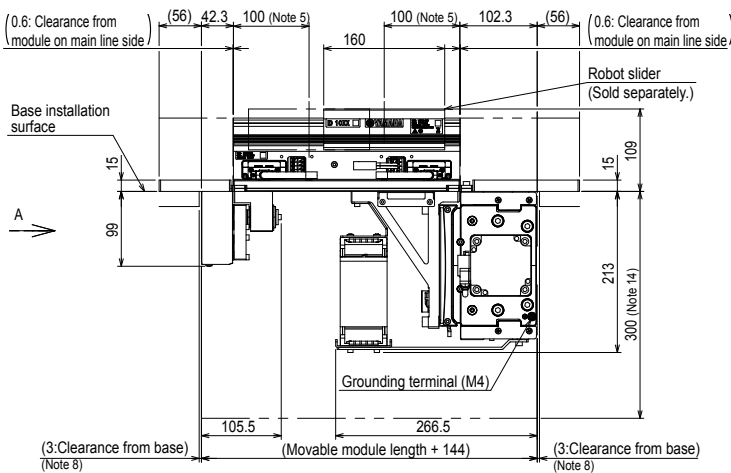
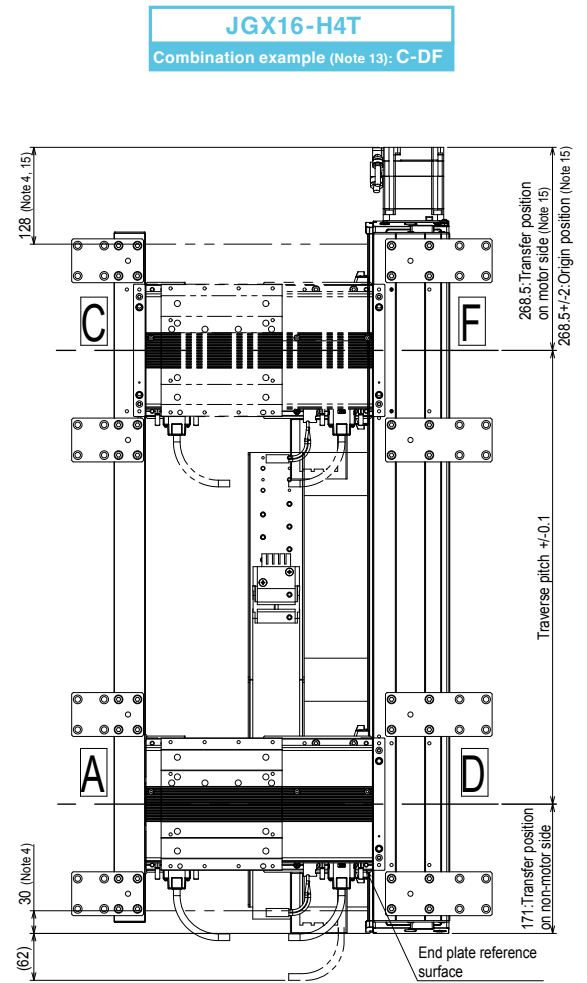
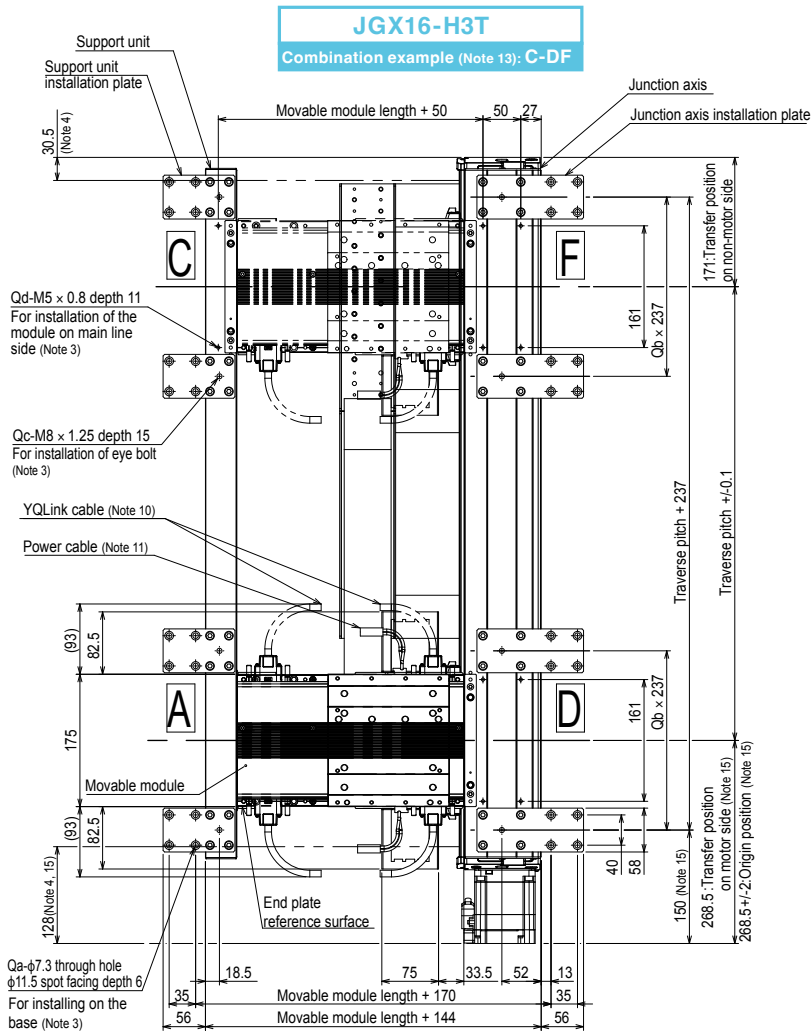

- Note 1. For details about the installation and operation procedures, see the user's manual.
- Note 2. The user wiring cannot be passed through the flexible cable carrier.
- Note 3. Do not use the installation hole at each location for an application other than that specified.
- Note 4. Movable module position when the junction axis is stopped by the mechanical stopper.
- Note 5. Robot slider unstoppage range from the module end.
An unstoppage range of 100 mm may vary depending on the pallet length.
For details, see the YHX User's Manual.
- Note 6. 2-slider simultaneous traverse is possible only when the movable module is a 500 mm module.
- Note 7. When the pallet length is 200 mm or more, this pitch is "pallet length + 10 mm".
However, when two sliders start at the same time, the minimum pitch is 250 mm or "pallet length + 50 mm".
- Note 8. Reference value for installation of the base.
Perform the installation so that the junction axis and support unit are not in contact with the end face of the installation base.
- Note 9. The robot cable fixing R is R30. The lead-out direction may vary depending on the specifications.
- Note 10. The YQLink cable fixing R is R55. This cable may become the termination connector depending on the specifications.
- Note 11. The power cable fixing R is R55.
- Note 12. The weight of the main body is a reference value. The weights of the module and robot slider are not included.
- Note 13. The module installation position on the main line side can be selected from the following combinations.
The end plate for positioning the module on the main line side is installed only at the selected combination position.
The module on the main line side cannot be installed at a position other than the selected combination.
- AC-D •A-DF
 - AC-F •C-DF
- Note 14. A maintenance space of 300 mm must be maintained below the top surface of the installation base.
- Note 15. For the battery-less absolute, a length of 8 mm is added.

Traverse pitch	200	250	300	350	400	450	500	550	600	650	700	750	800
La	639.5	689.5	739.5	789.5	839.5	889.5	939.5	989.5	1039.5	1089.5	1139.5	1189.5	1239.5
Lb	542.5	592.5	642.5	692.5	742.5	792.5	842.5	892.5	942.5	992.5	1042.5	1092.5	1142.5
Lc	196.5	253.5	307.5	60.5	85.5	171.5	196.5	251.5	306.5	361.5	416.5	471.5	496.5
Ld	300	300	300	601	601	601	601	601	601	601	601	601	601
Qa	16	16	32	32	32	32	32	32	32	32	32	32	32
Qb	0	0	1	1	1	1	1	1	1	1	1	1	1
Qc	4	4	8	8	8	8	8	8	8	8	8	8	8
Weight (Kg)(Note 12)	37.0	38.5	41.8	44.1	45.5	46.9	48.5	49.9	51.5	52.9	54.4	55.9	57.4
Maximum speed (mm/sec)	Lead 40	2400											
	Lead 20	1200											
	Speed setting	-											

Traverse pitch	850	900	950	1000	1050	1100	1150	1200	1250	1300	1350
La	1289.5	1339.5	1389.5	1439.5	1489.5	1539.5	1589.5	1639.5	1689.5	1739.5	1789.5
Lb	1192.5	1242.5	1292.5	1342.5	1392.5	1442.5	1492.5	1542.5	1592.5	1642.5	1692.5
Lc	553.5	607.5	360.5	385.5	471.5	496.5	551.5	606.5	661.5	716.5	771.5
Ld	601	601	902	902	902	902	902	902	902	902	902
Qa	32	32	32	32	32	32	32	32	32	32	32
Qb	1	1	1	1	1	1	1	1	1	1	1
Qc	8	8	8	8	8	8	8	8	8	8	8
Weight (Kg)(Note 12)	58.9	60.4	62.6	64.2	65.6	67.2	68.6	70.1	71.6	73.1	74.6
Maximum speed (mm/sec)	Lead 40	2160	1920	1680	1440	1320	1200	1080	960	840	720
	Lead 20	1080	960	840	720	660	600	540	480	420	360
	Speed setting	90%	80%	70%	60%	55%	50%	45%	40%	35%	30%

Combination	•AC-D	•A-DF
	•AC-F	•C-DF
Qd	8	10

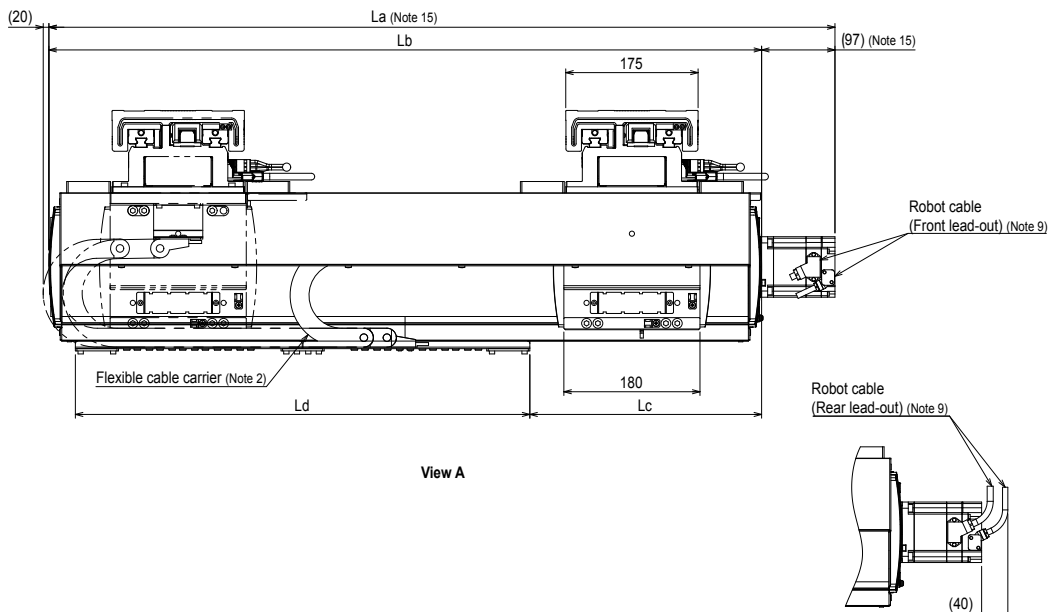

Traversing unit External view

3-row branching specifications

JGX16-H1T/H2T

JGX16-H2T
Combination example (Note 14): ABC-F

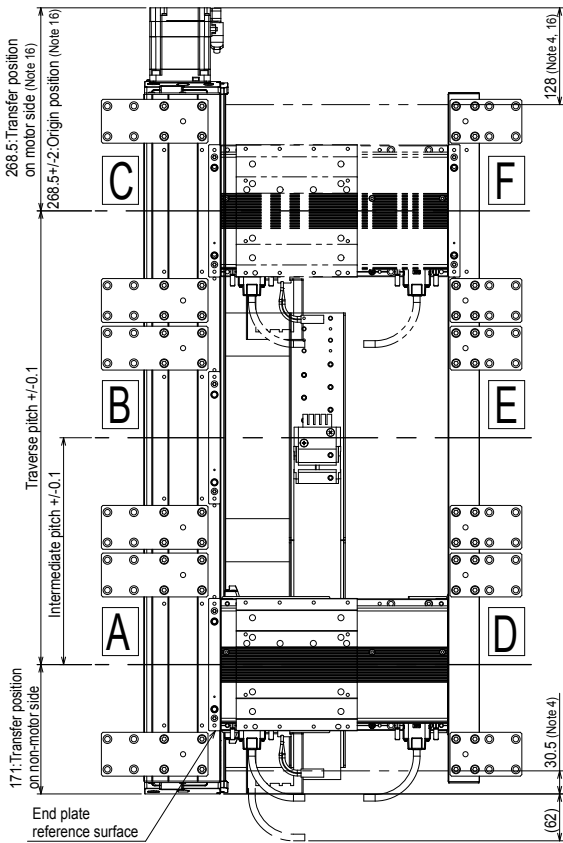

JGX16-H1T
Combination example (Note 14): ABC-F

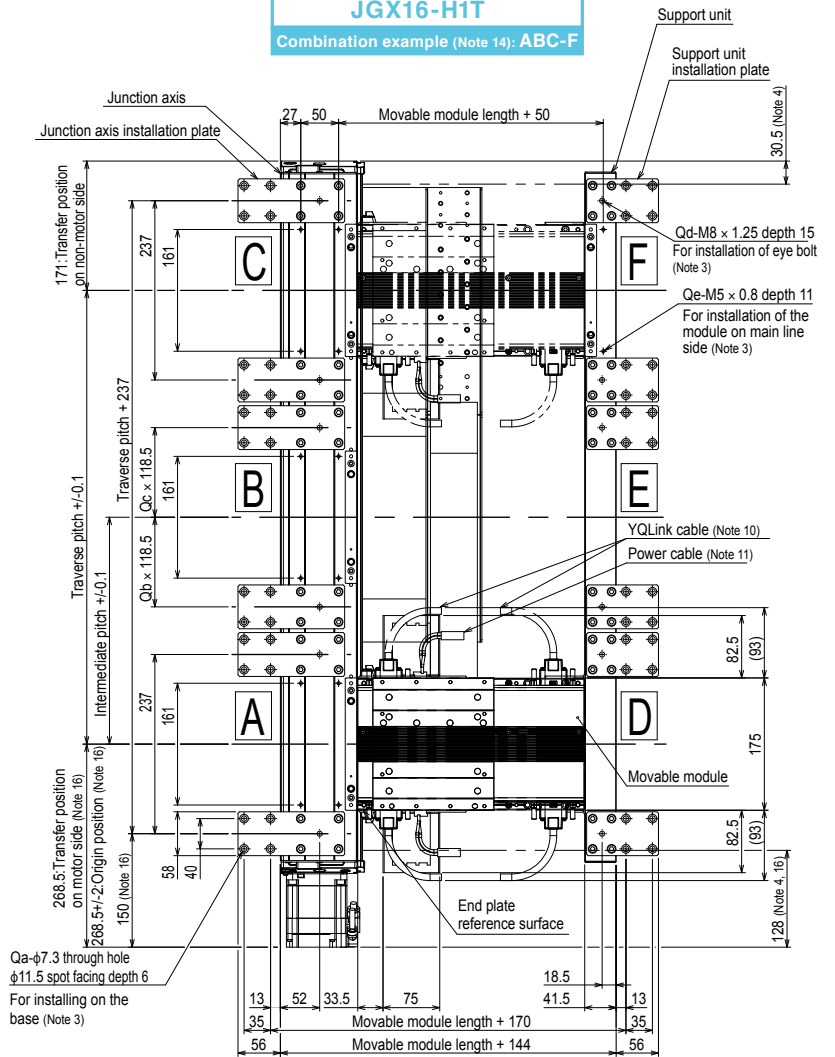

Qa-φ7.3 through hole
φ11.5 spot facing depth 6
For installing on the
base (Note 3)

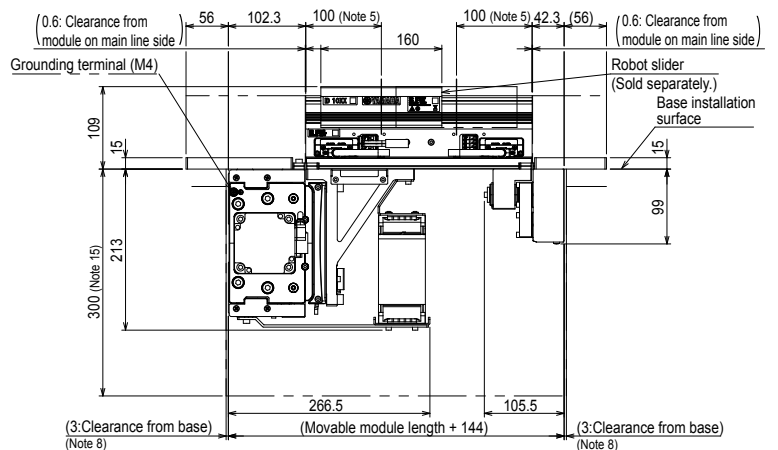
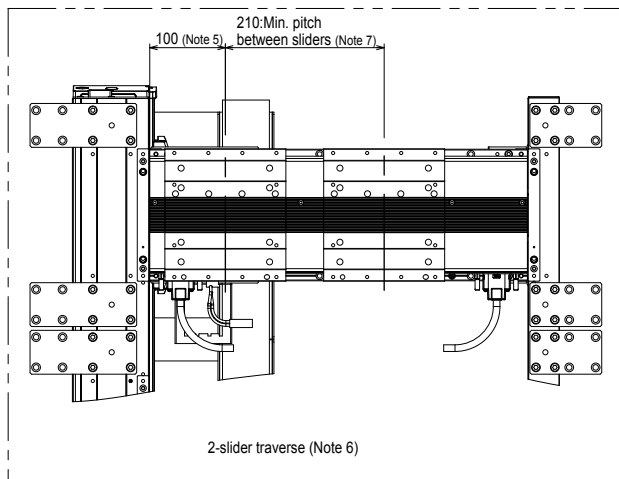

- Note 1. For details about the installation and operation procedures, see the user's manual.
 Note 2. The user wiring cannot be passed through the flexible cable carrier.
 Note 3. Do not use the installation hole at each location for an application other than that specified.
 Note 4. Movable module position when the junction axis is stopped by the mechanical stopper.
 Note 5. Robot slider unstoppage range from the module end.
 An unstoppage range of 100 mm may vary depending on the pallet length.
 For details, see the YHX User's Manual.
 Note 6. 2-slider simultaneous traverse is possible only when the movable module is a 500 mm module.
 Note 7. When the pallet length is 200 mm or more, this pitch is "pallet length + 10 mm".
 However, when two sliders start at the same time, the minimum pitch is 250 mm or "pallet length + 50 mm".
 Note 8. Reference value for installation of the base.
 Perform the installation so that the junction axis and support unit are not in contact with the end face of the installation base.
 Note 9. The robot cable fixing R is R30. The lead-out direction may vary depending on the specifications.
 Note 10. The YQLink cable fixing R is R55. This cable may become the termination connector depending on the specifications.
 Note 11. The power cable fixing R is R55.
 Note 12. The weight of the main body is a reference value. The weights of the module and robot slider are not included.
 Note 13. The intermediate pitch can be selected in 50 mm increments. The selectable intermediate pitch may vary depending on the traverse pitch.
 Note 14. The module installation position on the main line side can be selected from the following combinations.
 The end plate for positioning the module on the main line side is installed only at the selected combination position.
 The module on the main line side cannot be installed at a position other than the selected combination.
 •ABC-D •A-DEF •AC-E
 •ABC-E •B-DEF •B-DF
 •ABC-F •C-DEF
- Note 15. A maintenance space of 300 mm must be maintained below the top surface of the installation base.
 Note 16. For the battery-less absolute, a length of 8 mm is added.

Traverse pitch	500	550	600	650	700	750	800	850	900	
Intermediate pitch (Note 13)	250	250 to 300	250 to 350	250 to 400	250 to 450	250 to 500	250 to 550	250 to 600	250 to 650	
La	939.5	989.5	1039.5	1089.5	1139.5	1189.5	1239.5	1289.5	1339.5	
Lb	842.5	892.5	942.5	992.5	1042.5	1092.5	1142.5	1192.5	1242.5	
Lc	196.5	251.5	306.5	361.5	416.5	471.5	496.5	553.5	607.5	
Ld	601	601	601	601	601	601	601	601	601	
Weight (Kg)(Note 12)	48.5	49.9	51.5	52.9	54.4	55.9	57.4	58.9	60.4	
Maximum speed (mm/sec)	Lead 40	2400						2160		1920
	Lead 20	1200						1080		960
	Speed setting	-						90%		80%

Traverse pitch	950	1000	1050	1100	1150	1200	1250	1300	1350
Intermediate pitch (Note 13)	250 to 700	250 to 750	250 to 800	250 to 850	250 to 900	250 to 950	250 to 1000	250 to 1050	250 to 1100
La	1389.5	1439.5	1489.5	1539.5	1589.5	1639.5	1689.5	1739.5	1789.5
Lb	1292.5	1342.5	1392.5	1442.5	1492.5	1542.5	1592.5	1642.5	1692.5
Lc	360.5	385.5	471.5	496.5	551.5	606.5	661.5	716.5	771.5
Ld	902	902	902	902	902	902	902	902	902
Weight (Kg)(Note 12)	62.6	64.2	65.6	67.2	68.6	70.1	71.6	73.1	74.6
Maximum speed (mm/sec)	Lead 40	1680	1440	1320	1200	1080	960		840
	Lead 20	840	720	660	600	540	480		420
	Speed setting	70%	60%	55%	50%	45%	40%		35%

	Intermediate pitch = 250	(Traverse pitch) - (Intermediate pitch) = 250	Traverse pitch = 500 and Intermediate pitch = 250	Others
Qa	40	40	32	48
Qb	0	1	0	1
Qc	1	0	0	1
Qd	10	10	8	12

Combination	•ABC-D •ABC-E •ABC-F	•A-DEF •B-DEF •C-DEF •AC-E	•B-DF
Qe	14	10	8

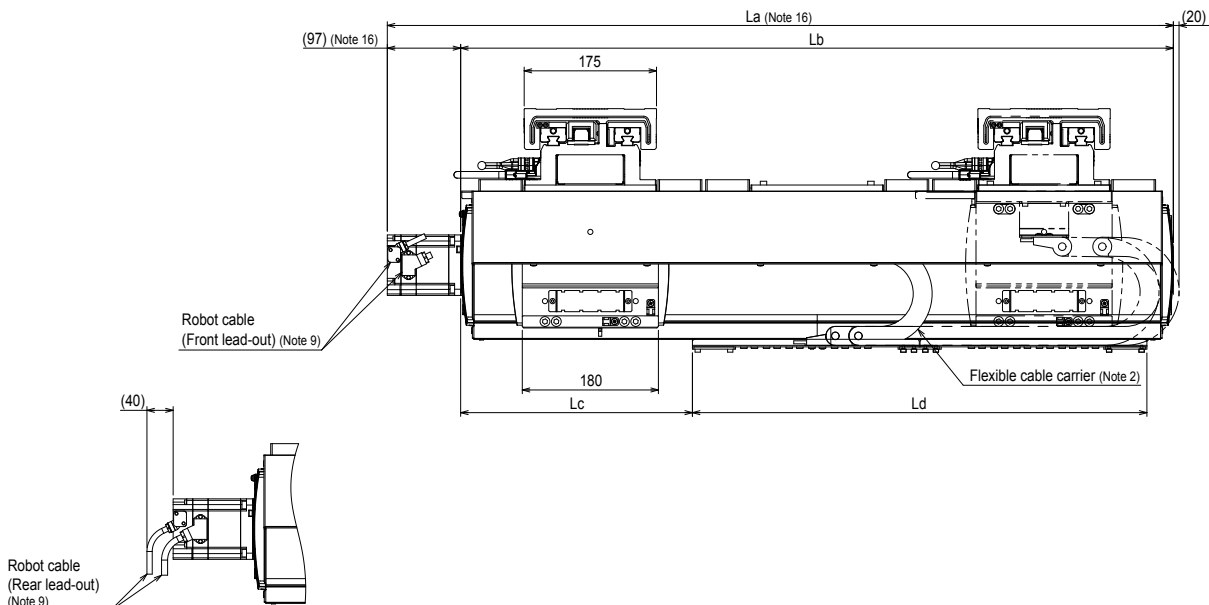

Traversing unit External view

3-row branching specifications

JGX16-H3T/H4T

JGX16-H3T
Combination example (Note 14): C-DEF

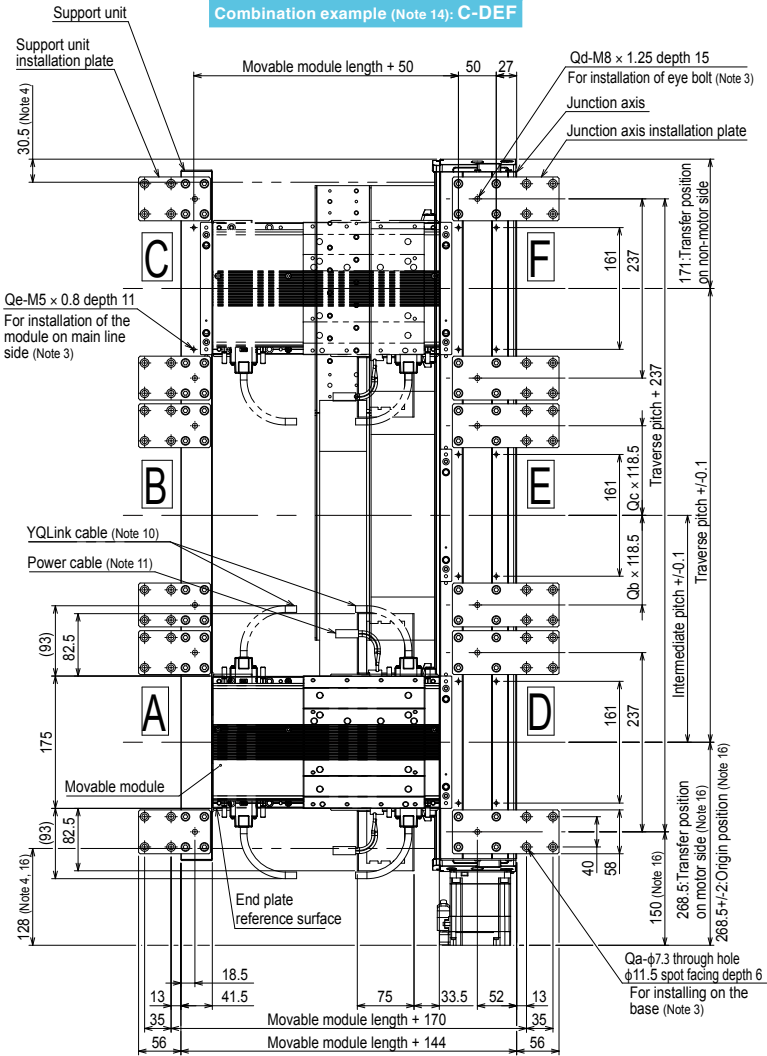

JGX16-H4T
Combination example (Note 14): C-DEF

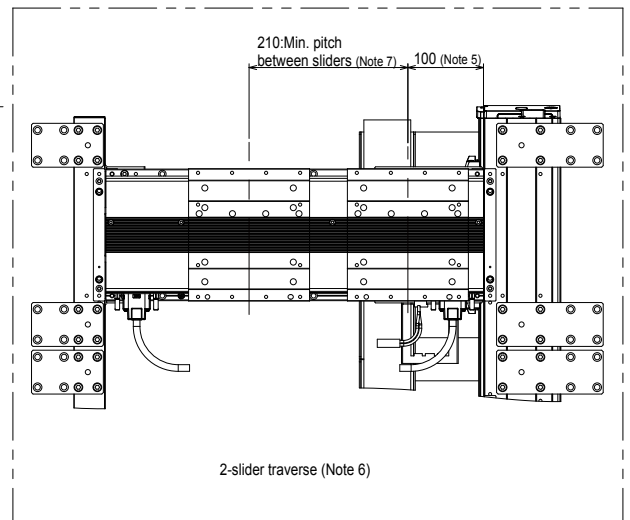
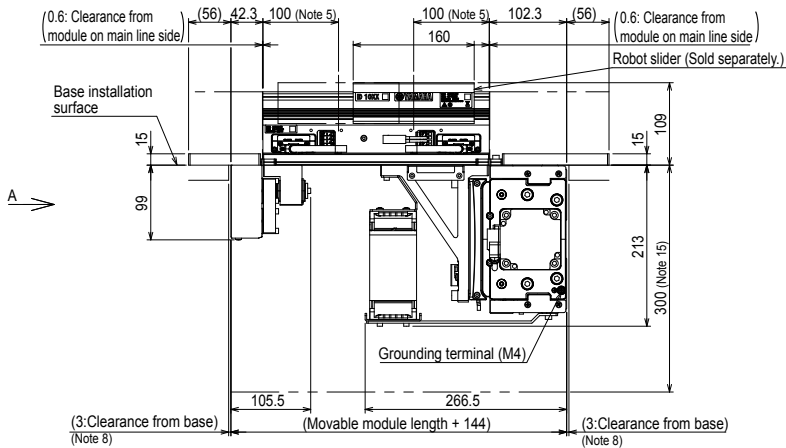
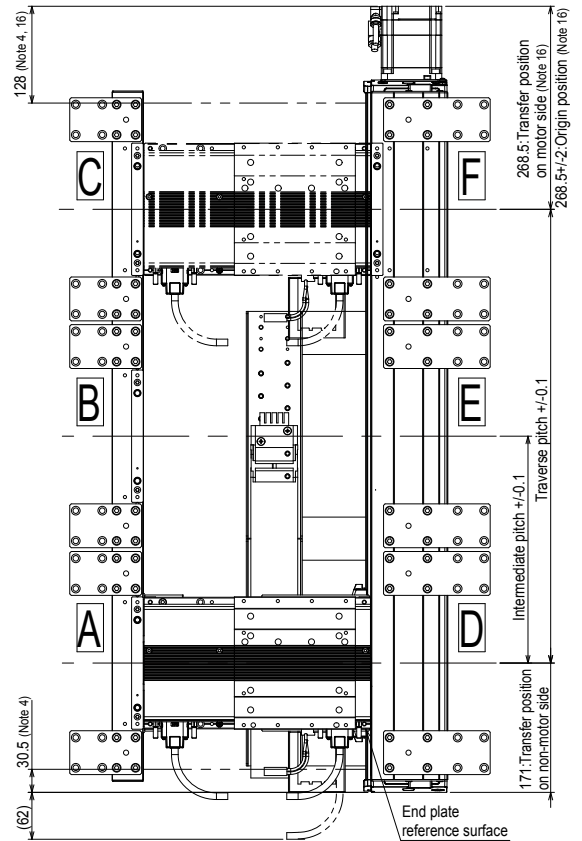

- Note 1. For details about the installation and operation procedures, see the user's manual.
 Note 2. The user wiring cannot be passed through the flexible cable carrier.
 Note 3. Do not use the installation hole at each location for an application other than that specified.
 Note 4. Movable module position when the junction axis is stopped by the mechanical stopper.
 Note 5. Robot slider unstoppage range from the module end.
 An unstoppage range of 100 mm may vary depending on the pallet length.
 For details, see the YHX User's Manual.
 Note 6. 2-slider simultaneous traverse is possible only when the movable module is a 500 mm module.
 Note 7. When the pallet length is 200 mm or more, this pitch is "pallet length + 10 mm".
 However, when two sliders start at the same time, the minimum pitch is 250 mm or "pallet length + 50 mm".
 Note 8. Reference value for installation of the base.
 Perform the installation so that the junction axis and support unit are not in contact with the end face of the installation base.
 Note 9. The robot cable fixing R is R30. The lead-out direction may vary depending on the specifications.
 Note 10. The YQLink cable fixing R is R55. This cable may become the termination connector depending on the specifications.
 Note 11. The power cable fixing R is R55.
 Note 12. The weight of the main body is a reference value. The weights of the module and robot slider are not included.
 Note 13. The intermediate pitch can be selected in 50 mm increments. The selectable intermediate pitch may vary depending on the traverse pitch.
 Note 14. The module installation position on the main line side can be selected from the following combinations.
 The end plate for positioning the module on the main line side is installed only at the selected combination position.
 The module on the main line side cannot be installed at a position other than the selected combination.
 •ABC-D •A-DEF •AC-E
 •ABC-E •B-DEF •B-DF
 •ABC-F •C-DEF
- Note 15. A maintenance space of 300 mm must be maintained below the top surface of the installation base.
 Note 16. For the battery-less absolute, a length of 8 mm is added.

Traverse pitch	500	550	600	650	700	750	800	850	900	
Intermediate pitch (Note 13)	250	250 to 300	250 to 350	250 to 400	250 to 450	250 to 500	250 to 550	250 to 600	250 to 650	
La	939.5	989.5	1039.5	1089.5	1139.5	1189.5	1239.5	1289.5	1339.5	
Lb	842.5	892.5	942.5	992.5	1042.5	1092.5	1142.5	1192.5	1242.5	
Lc	196.5	251.5	306.5	361.5	416.5	471.5	496.5	553.5	607.5	
Ld	601	601	601	601	601	601	601	601	601	
Weight (Kg)(Note 12)	48.5	49.9	51.5	52.9	54.4	55.9	57.4	58.9	60.4	
Maximum speed (mm/sec)	Lead 40	2400						2160		1920
	Lead 20	1200						1080		960
	Speed setting	-						90%		80%

Traverse pitch	950	1000	1050	1100	1150	1200	1250	1300	1350	
Intermediate pitch (Note 13)	250 to 700	250 to 750	250 to 800	250 to 850	250 to 900	250 to 950	250 to 1000	250 to 1050	250 to 1100	
La	1389.5	1439.5	1489.5	1539.5	1589.5	1639.5	1689.5	1739.5	1789.5	
Lb	1292.5	1342.5	1392.5	1442.5	1492.5	1542.5	1592.5	1642.5	1692.5	
Lc	360.5	385.5	471.5	496.5	551.5	606.5	661.5	716.5	771.5	
Ld	902	902	902	902	902	902	902	902	902	
Weight (Kg)(Note 12)	62.6	64.2	65.6	67.2	68.6	70.1	71.6	73.1	74.6	
Maximum speed (mm/sec)	Lead 40	1680	1440	1320	1200	1080	960		840	720
	Lead 20	840	720	660	600	540	480		420	360
	Speed setting	70%	60%	55%	50%	45%	40%		35%	30%

	Intermediate pitch = 250	(Traverse pitch) - (Intermediate pitch) = 250	Traverse pitch = 500 and Intermediate pitch = 250	Others
Qa	40	40	32	48
Qb	0	1	0	1
Qc	1	0	0	1
Qd	10	10	8	12

Combination	•ABC-D •ABC-E •ABC-F •B-DF	•A-DEF •B-DEF •C-DEF	•AC-E
Qe	10	14	8

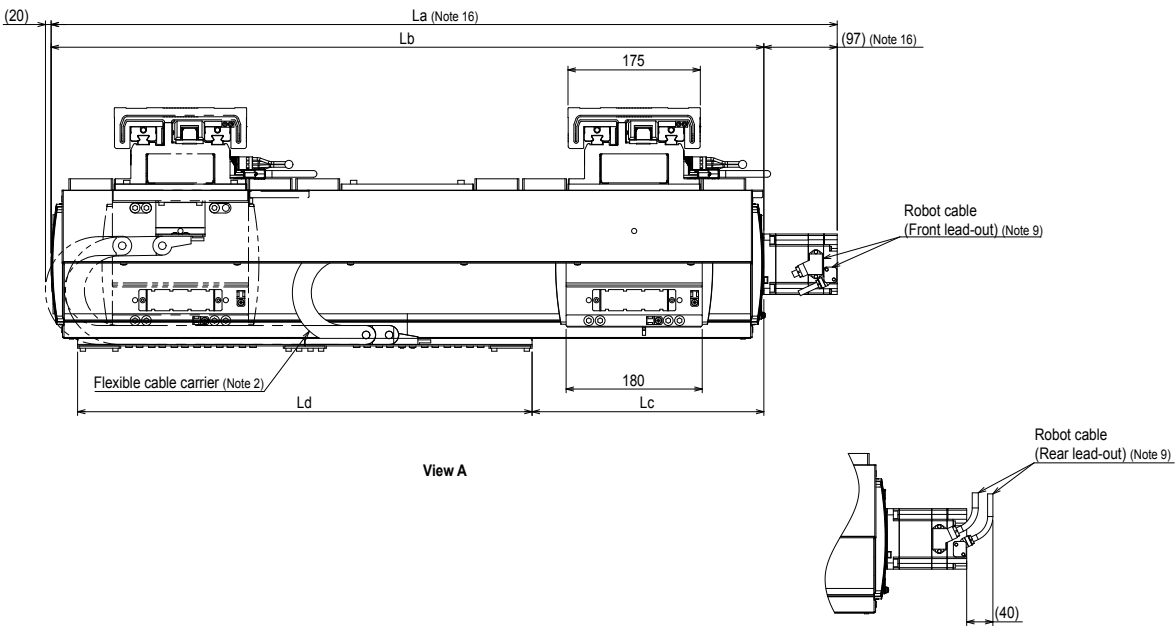

Traversing unit External view

Retracting specifications

JGX16-H1T/H2T

JGX16-H2T
Combination example (Note 14): B-E

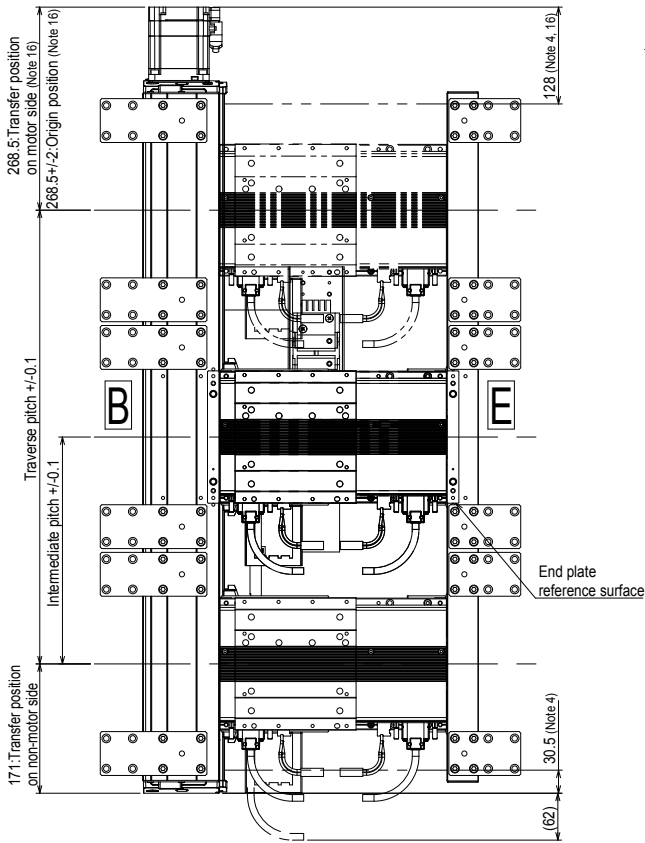

JGX16-H1T
Combination example (Note 14): B-E

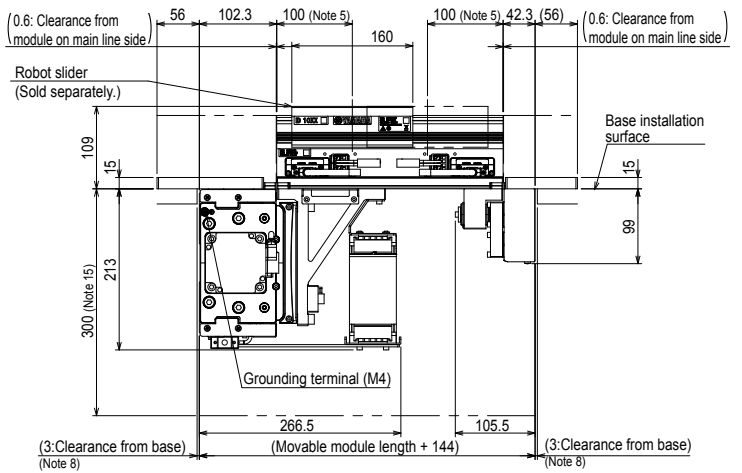
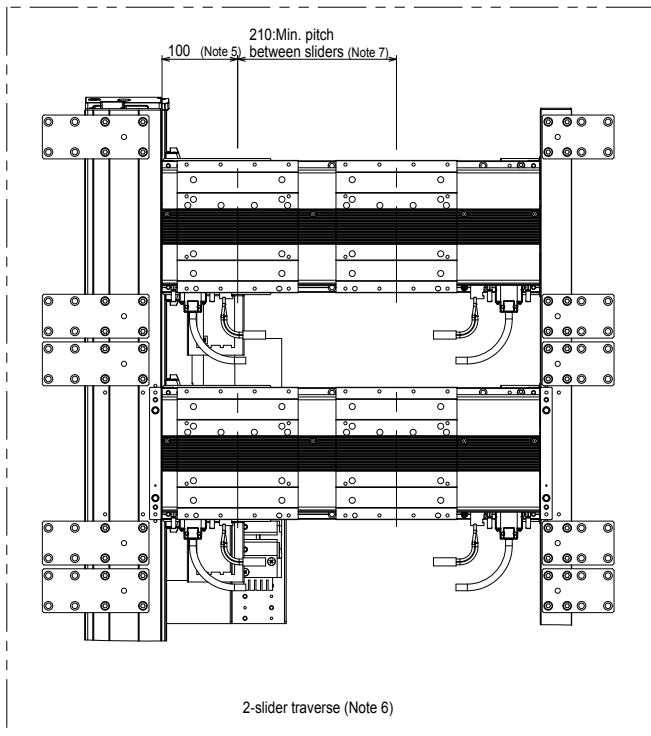
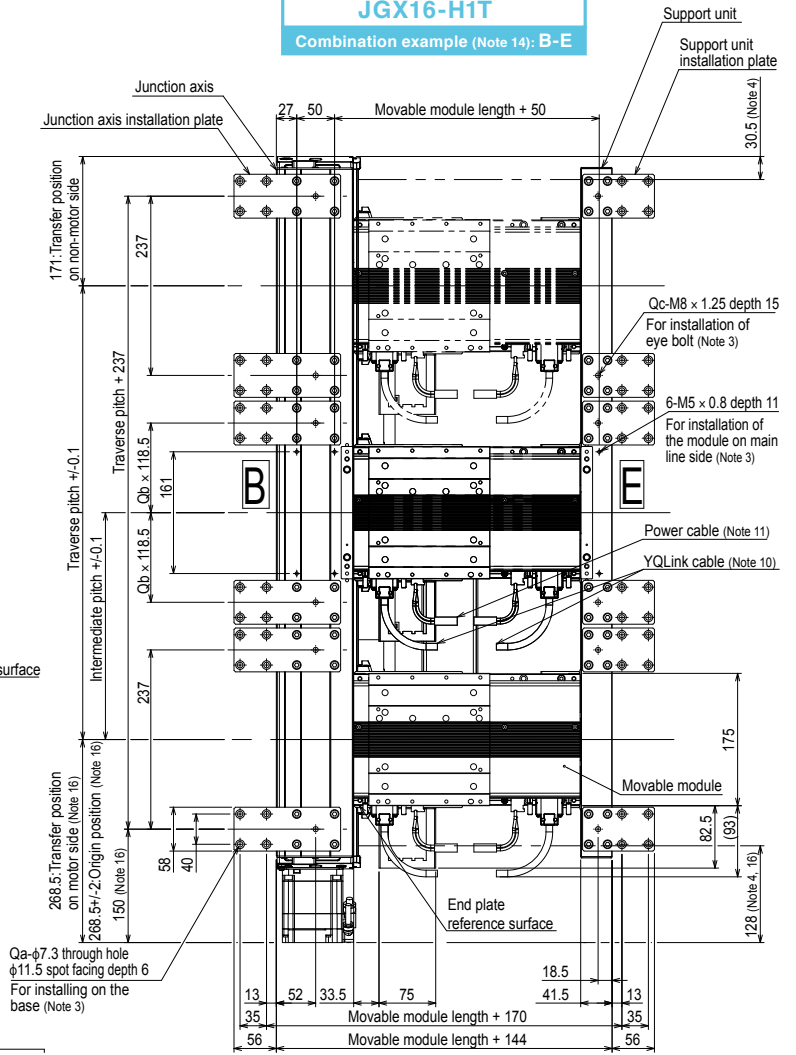

- Note 1. For details about the installation and operation procedures, see the user's manual.
- Note 2. The user wiring cannot be passed through the flexible cable carrier.
- Note 3. Do not use the installation hole at each location for an application other than that specified.
- Note 4. Movable module position when the junction axis is stopped by the mechanical stopper.
- Note 5. Robot slider unstoppage range from the module end.
An unstoppage range of 100 mm may vary depending on the pallet length.
For details, see the YHX User's Manual.
- Note 6. 2-slider simultaneous traverse is possible only when the movable module is a 500 mm module.
- Note 7. When the pallet length is 200 mm or more, this pitch is "pallet length + 10 mm".
However, when two sliders start at the same time, the minimum pitch is 250 mm or "pallet length + 50 mm".
- Note 8. Reference value for installation of the base.
Perform the installation so that the junction axis and support unit are not in contact with the end face of the installation base.
- Note 9. The robot cable fixing R is R30. The lead-out direction may vary depending on the specifications.
- Note 10. The YQLink cable fixing R is R55. This cable may become the termination connector depending on the specifications.
- Note 11. The power cable fixing R is R55.
- Note 12. The weight of the main body is a reference value. The weights of the module and robot slider are not included.
- Note 13. The intermediate pitch can be selected only at the half value of the traverse pitch.
- Note 14. The module installation position on the main line side can be selected from the following combinations.
The end plate for positioning the module on the main line side is installed only at the selected combination position.
The module on the main line side cannot be installed at a position other than the selected combination.
•B-E
- Note 15. A maintenance space of 300 mm must be maintained below the top surface of the installation base.
- Note 16. For the battery-less absolute, a length of 8 mm is added.

Traverse pitch	500	600	700	800	900	1000	1100	1200	1300
Intermediate pitch (Note 13)	250	300	350	400	450	500	550	600	650
La	939.5	1039.5	1139.5	1239.5	1339.5	1439.5	1539.5	1639.5	1739.5
Lb	842.5	942.5	1042.5	1142.5	1242.5	1342.5	1442.5	1542.5	1642.5
Lc	253.5	307.5	60.5	85.5	171.5	196.5	251.5	306.5	361.5
Ld	300	300	601	601	601	601	601	601	601
Weight (Kg)(Note 12)	58.0	61.2	64.3	67.5	70.7	74.7	77.9	81.0	84.2
Maximum speed (mm/sec)	Lead 40	2400			1920	1440	1200	960	840
	Lead 20	1200			960	720	600	480	420
	Speed setting	-			80%	60%	50%	40%	35%

	Traverse pitch = 500 (Intermediate pitch = 250)	Others
Qa	32	48
Qb	0	1
Qc	8	12

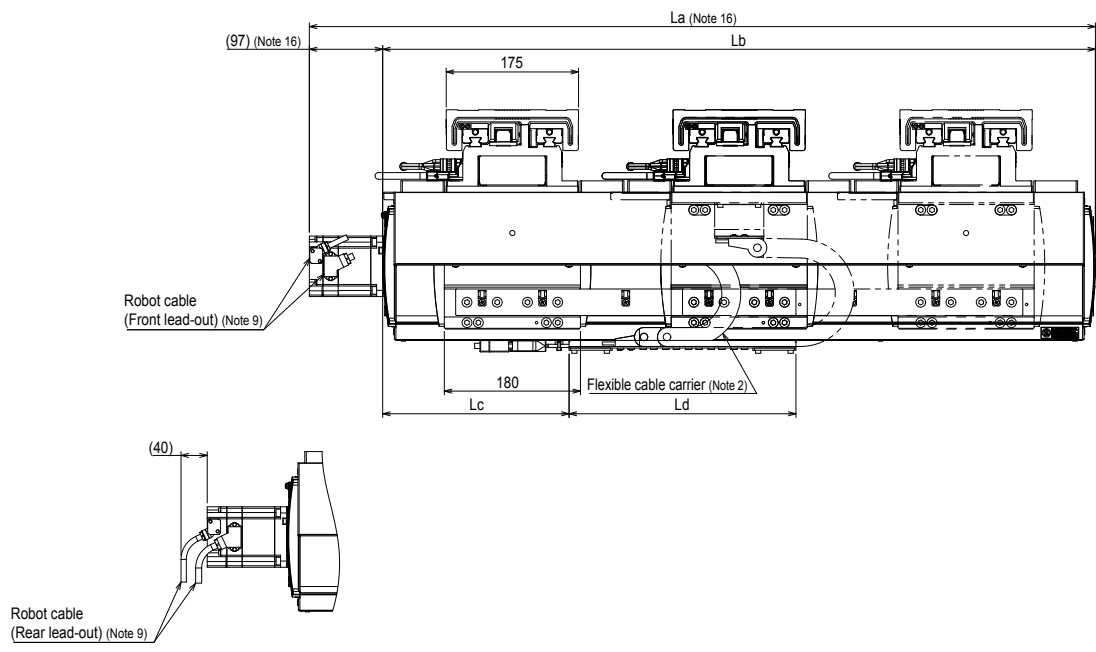

Traversing unit External view

Retracting specifications

JGX16-H3T/H4T

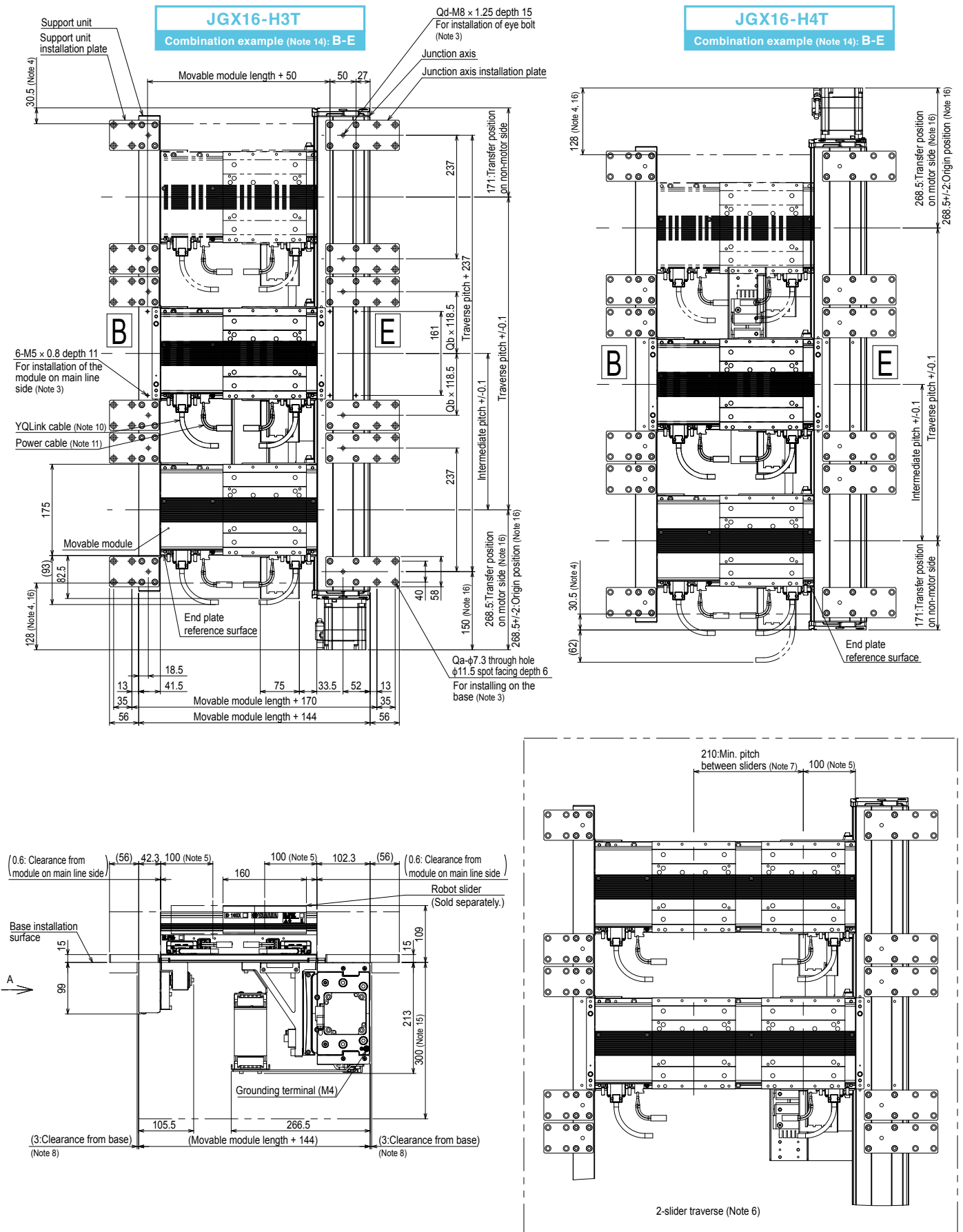

- Note 1. For details about the installation and operation procedures, see the user's manual.
 Note 2. The user wiring cannot be passed through the flexible cable carrier.
 Note 3. Do not use the installation hole at each location for an application other than that specified.
 Note 4. Movable module position when the junction axis is stopped by the mechanical stopper.
 Note 5. Robot slider unstoppable range from the module end.
 An unstoppable range of 100 mm may vary depending on the pallet length.
 For details, see the YHX User's Manual.
 Note 6. 2-slider simultaneous traverse is possible only when the movable module is a 500 mm module.
 Note 7. When the pallet length is 200 mm or more, this pitch is "pallet length + 10 mm".
 However, when two sliders start at the same time, the minimum pitch is 250 mm or "pallet length + 50 mm".
 Note 8. Reference value for installation of the base.
 Perform the installation so that the junction axis and support unit are not in contact with the end face of the installation base.
 Note 9. The robot cable fixing R is R30. The lead-out direction may vary depending on the specifications.
 Note 10. The YQLink cable fixing R is R55. This cable may become the termination connector depending on the specifications.
 Note 11. The power cable fixing R is R55.
 Note 12. The weight of the main body is a reference value. The weights of the module and robot slider are not included.
 Note 13. The intermediate pitch can be selected only at the half value of the traverse pitch.
 Note 14. The module installation position on the main line side can be selected from the following combinations.
 The end plate for positioning the module on the main line side is installed only at the selected combination position.
 The module on the main line side cannot be installed at a position other than the selected combination.
 •B-E
 Note 15. A maintenance space of 300 mm must be maintained below the top surface of the installation base.
 Note 16. For the battery-less absolute, a length of 8 mm is added.

Traverse pitch	500	600	700	800	900	1000	1100	1200	1300
Intermediate pitch (Note 13)	250	300	350	400	450	500	550	600	650
La	939.5	1039.5	1139.5	1239.5	1339.5	1439.5	1539.5	1639.5	1739.5
Lb	842.5	942.5	1042.5	1142.5	1242.5	1342.5	1442.5	1542.5	1642.5
Lc	253.5	307.5	60.5	85.5	171.5	196.5	251.5	306.5	361.5
Ld	300	300	601	601	601	601	601	601	601
Weight (Kg)(Note 12)	58.0	61.2	64.3	67.5	70.7	74.7	77.9	81.0	84.2
Maximum speed (mm/sec)	Lead 40	2400			1920	1440	1200	960	840
	Lead 20	1200			960	720	600	480	420
	Speed setting	-			80%	60%	50%	40%	35%

	Traverse pitch = 500 (Intermediate pitch = 250)	Others
Qa	32	48
Qb	0	1
Qc	8	12

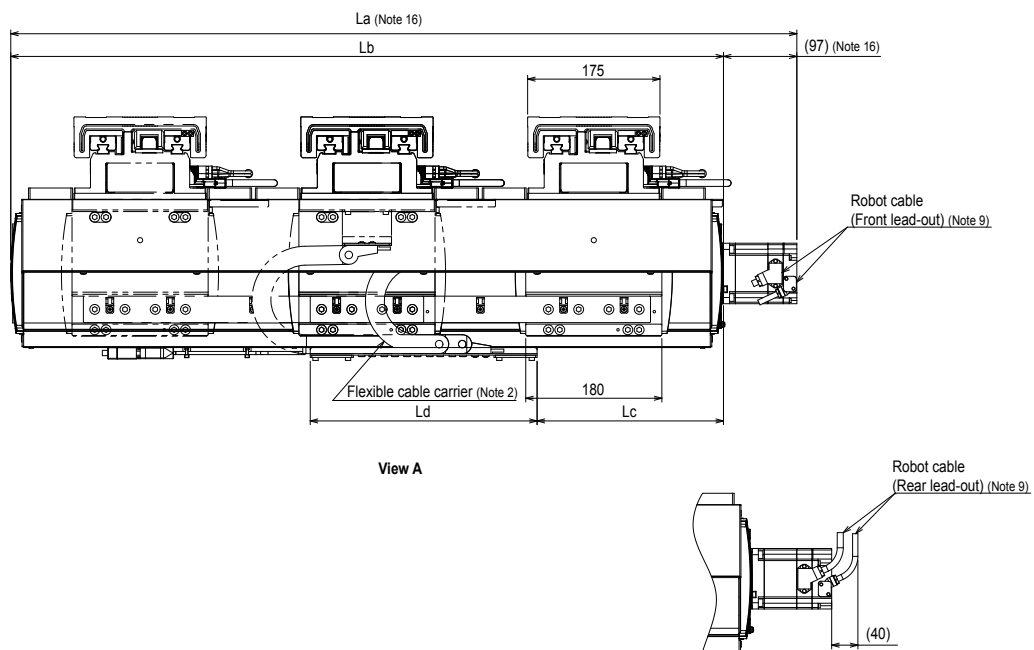

Circulation unit / Traversing unit option

Circulation unit / Traversing unit transfer accuracy measurement jig

Using this jig improves the workability when the following is measured.

- Transfer section teaching accuracy when YAMAHA genuine circulation unit and traversing unit are used.
- Accuracy of the transfer section when the circulation part designed by the customer is used.
- Installation accuracy of linear modules that are connected with the adjuster plate.

Applicable model	Model (Japan)	Model (Other countries) ¹
Circulation designed by the customer	KNA-M2930-00	KNA-M2930-A0
YAMAHA horizontal circulation · Traversing unit JGX16-H,-T	KNA-M2930-10	KNA-M2930-B0
YAMAHA vertical circulation JGX16-V	KNA-M2930-20 ²	

¹: Please order the model for other countries in countries other than Japan.

The models for other countries (KNA-M2930-A0, KNA-M2930-B0) have a $\phi 8$ installation hole for the test indicator holder.

²: The model for JGX16-V is common to Japan and other countries.

For circulation designed by customer KNA-M2930-00 (Japan) / KNA-M2930-A0 (Other countries)	For JGX16-H,-T KNA-M2930-10 (Japan) / KNA-M2930-B0 (Other countries)	For JGX16-V KNA-M2930-20 (Common to Japan and other countries)
---	---	---

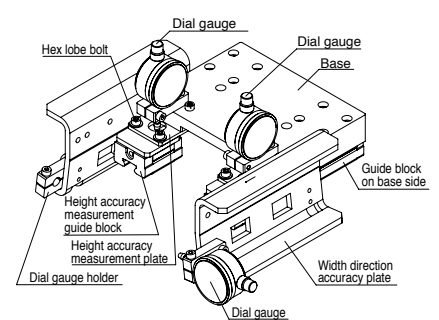
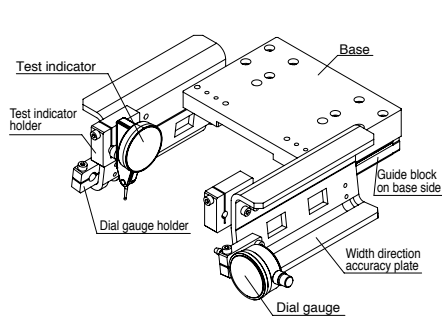
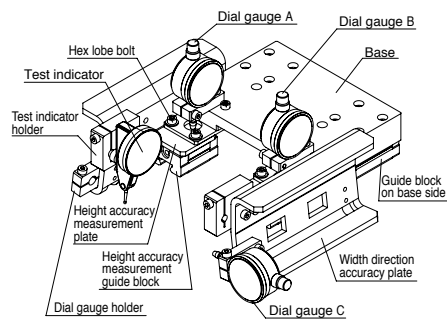

* This product does not include dial gauge and test indicator. The figure shows an image when dial gauge and test indicator are installed.

Specifications

Item		For circulation designed by customer KNA-M2930-00 (Japan) / KNA-M2930-A0 (Other countries)	For JGX16-H,-T KNA-M2930-10 (Japan) / KNA-M2930-B0 (Other countries)	For JGX16-V KNA-M2930-20 (Common to Japan and other countries)
Outside dimensions	Main body only ¹	W206mm x D207mm x H75mm	W206mm x D207mm x H75mm	W206mm x D207mm x H75mm
	When measuring instrument is installed ²	W242mm x D213mm x H121mm	W242mm x D213mm x H92mm	W242mm x D210mm x H121mm
Weight	Main body only	2.5kg	2.1kg	2.4kg
	When measuring instrument is installed ²	2.8kg	2.2kg	2.6kg

¹: This product does not include dial gauge and test indicator.

Please select a dial gauge with an installation hole diameter of $\phi 6$ for the dial gauge holder and a test indicator with an installation hole diameter of $\phi 6$ for the test indicator holder for Japan or $\phi 8$ for other countries.

²: YAMAHA's recommended dial gauge (Mitutoyo, model 1109AB-10), and test indicator (Mitutoyo, model 513-425-10H for Japan) or (Mitutoyo, model 513-425-10E for other countries)

No measuring instrument is installed.

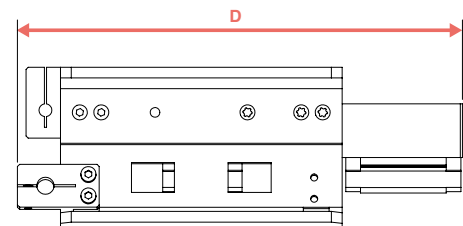
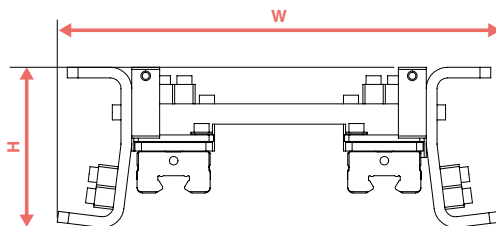

Measuring instrument is installed.

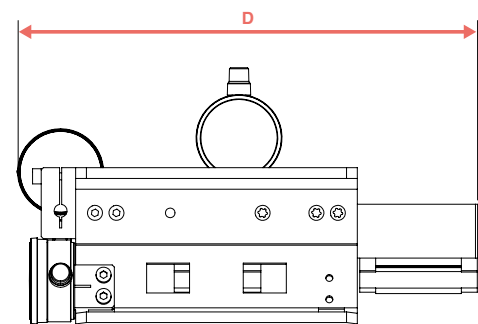
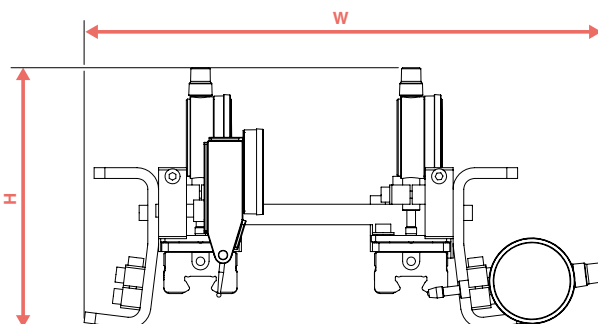

[Cautions]

- A (Side where there is the front line): A length of at least 170 mm is maintained from the bottom of the linear module.
 - B: A length of at least 51 mm is maintained from the end of the linear module.
- If above spaces cannot be maintained, any part of the measuring jig may interfere with a peripheral device on the equipment side. Therefore, the measuring jig cannot be used on the linear module.

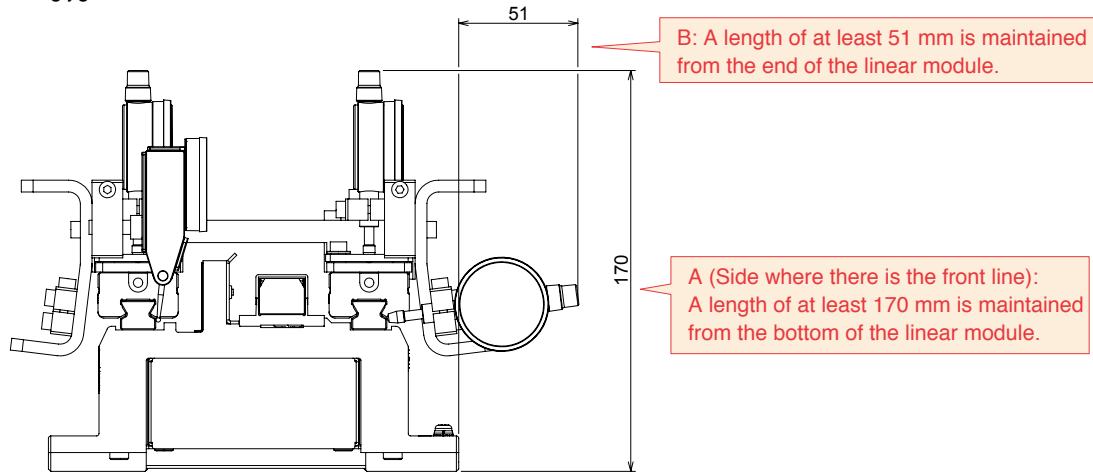

* This product does not include dial gauge and test indicator.
 The above size is when YAMAHA's recommended dial gauge (Mitutoyo, model 1109AB-10) and test indicator (Mitutoyo, model 513-425-10H) are installed.
 The size may vary depending on the dial gauge to be installed.

About selection of measuring instrument

Select a dial gauge and test indicator that satisfy the following specifications.

■ Dial gauge

Measurement range	0.5mm or more
Measurement resolution	2μm or less
Stem diameter	φ8mm

■ Test indicator

Measurement range	0.5mm or more
Measurement resolution	2μm or less
Stem diameter	φ6mm (For Japan) ^{*1} / φ8mm (For other countries) ^{*2}
Others	① A dovetail groove (male) to install the stem is provided on the rear of the test indicator. ② A dovetail groove (female) is provided on the stem.

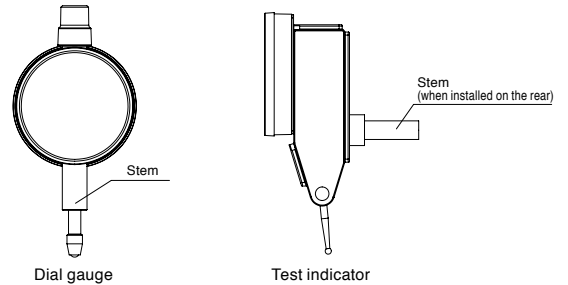

- Caution**
- About calibration of measuring instrument
 - The customer should calibrate each measuring instrument by the calibration guarantee date specified by the measuring instrument manufacturer.
 - For details about the calibration, contact the measuring instrument supplier.

*1: For accuracy measurement jigs for Japan (KNA-M2930-00, KNA-M2930-10)
 *2: For accuracy measurement jigs for other countries (KNA-M2930-A0, KNA-M2930-B0)

Transfer pallet size

Transferable pallet size table ^{*1}

	Unit	Linear module length	Pallet length [mm]			Pallet width [mm]			Pallet height [mm]	
			A	B	A+B	C	D	C+D		
Circulation unit	Recommended size at 1-slider circulates.	JGX16-H	200	99	99	198	Not restricted. ^{*2}			Not restricted. ^{*2}
			300	199	199	298				
			500	399	399	498				
		JGX16-V	200	99	99	198	150	150	300	Circulation pitch -220mm
			300	199	199	298				
			500	399	399	498				
	Maximum size at 1-slider circulates.	JGX16-H	200	99	99	198	Not restricted. ^{*2}			Not restricted. ^{*2}
			300	199	199	298				
			500	399	399	498				
		JGX16-V	200	99	99	198	150	150	300	Circulation pitch -220mm
			300	199	199	298				
			500	399	399	298				
Maximum size at 2-slider circulates.	JGX16-H	200	Unavailable.			Unavailable.			Unavailable.	
		300	Unavailable.			Unavailable.			Unavailable.	
		500	145 ^{*3}	145 ^{*3}	244 ^{*3}	Not restricted. ^{*2}			Not restricted. ^{*2}	
	JGX16-V	200	Unavailable.			Unavailable.			Unavailable.	
		300	Unavailable.			Unavailable.			Unavailable.	
		500	145 ^{*3}	145 ^{*3}	244 ^{*3}	150	150	300	Circulation pitch -220mm	
Traversing unit	Maximum size at 1-slider traverse ^{*4}	JGX16-T	200	99	99	198	Not restricted. ^{*2}			Not restricted. ^{*2}
			300	199	199	298				
			500	399	399	498				
	Maximum size at 2-slider traverse ^{*4}	JGX16-T	200	Unavailable.			Unavailable.			Unavailable.
			300	Unavailable.			Unavailable.			Unavailable.
			500	145 ^{*3}	145 ^{*3}	244 ^{*3}	Not restricted. ^{*2}			Not restricted. ^{*2}

- *1: The pallet size indicates the total size of the loads on the robot slider including the customer's workpieces. In addition, it is assumed that all pallets on the robot sliders have the same shape. For the horizontal circulation method, be aware that pallets or workpieces on the robot sliders that pass each other on the outbound and inbound routes do not collide with each other.
- *2: The allowable overhang amount must not be exceeded. Be aware that the robot sliders do not collide with each other between the main lines.
- *3: When either A or B is 122 mm or more, the pallet cannot be arranged at the center of the robot slider. It is assumed that all pallets on the robot sliders have the same shape.
- *4: The recommended pallet size of the traversing unit is the same as the maximum pallet size.

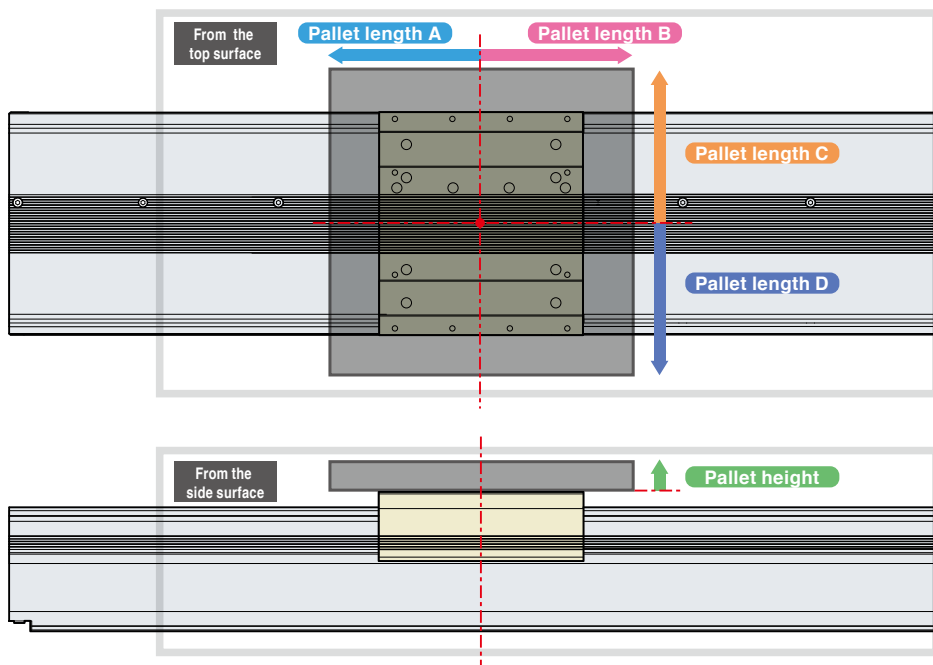

Maximum payload per robot slider/Allowable overhang amount

Maximum payload per robot slider

Model		Number of robot slider simultaneous circulation traverses	1			2		
			Ball screw lead ¹			10mm	20mm	40mm
Circulation unit (Horizontal)	JGX16-H	Maximum payload of robot slider	-	30	26	-	15	12
Circulation unit (Vertical)	JGX16-V		30	28	-	15	10	-
Traversing unit	JGX16-T		-	30	26	-	15	15

*1: Note that the optimal lead length may vary depending on the operating environment.

Allowable overhang amount

Model		Payload	5kg			10kg			15kg			
			A ³	B	C ⁴	A ³	B	C ⁴	A ³	B	C ⁴	
LCMR200		Overhang amount ¹	760	405	239	762	231	158	700	173	122	
Circulation unit (Horizontal)	JGX16-H	Number of robot slider simultaneous transfers	1 or 2			1 or 2			1 or 2			
		Overhang amount ²	760	405	239	762	231	158	700	173	122	
Circulation unit (Vertical)	JGX16-V	Number of robot slider simultaneous transfers	1 or 2	1	2	1 or 2	1	2	1 or 2	1	2	
		Overhang amount ²	380	405	150	150	380	231	150	100	380	173
Traversing unit	JGX16-T	Number of robot slider simultaneous transfers	1 or 2		1 or 2	1 or 2		1 or 2	1 or 2		1 or 2	
		Overhang amount ²	760	405	239	762	231	158	700	173	122	

Model		Payload	20kg			25kg			30kg		
			A ³	B	C ⁴	A ³	B	C ⁴	A ³	B	C ⁴
LCMR200		Overhang amount ¹	648	117	73	509	82	68	453	58	49
Circulation unit (Horizontal)	JGX16-H	Number of robot slider simultaneous transfers	1			1			1		
		Overhang amount ²	648	117	73	509	82	68	453	58	49
Circulation unit (Vertical)	JGX16-V	Number of robot slider simultaneous transfers	1			1			1		
		Overhang amount ²	380	117	73	380	82	68	380	58	49
Traversing unit	JGX16-T	Number of robot slider simultaneous transfers	1			1			1		
		Overhang amount ²	648	117	73	509	82	68	453	58	49

*1: Distance from the center of the robot slider top surface to the center of gravity of the transfer object when the service life of the guide is 10,000 km.

*2: Distance from the center of the top surface of the robot slider to the center of gravity of the load.

*3: When the circulation unit is inserted or ejected to/from the lower stage line, the pallet height needs to be "circulation pitch - 220 mm" or less.

*4: Be aware that the robot sliders do not interfere with each other between the main lines.

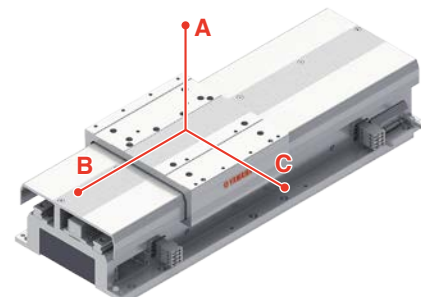

YHX controller

Controller

Order model: **YHX-HD** - [] - []

Controller	Language	Network
	J (Japanese)	N : None
	E (English)	CC : CC-Link ¹
		PT : PROFINET ²
		EP : EtherNet/IP ³
		ES : EtherCAT ⁴

- *1. CC-Link is a registered trade mark of Mitsubishi Electric Corporation.
- *2. PROFINET is a registered trade mark of PROFIBUS Nutzerorganisation e.V. (PNO).
- *3. EtherNet/IP is a registered trade mark of ODVA, Inc.
- *4. EtherCAT is a patented technology and a registered trademark licensed by Beckhoff Automation GmbH (Germany).

The YHX-HD is a set model of the host controller unit, driver power unit, and related components shown below. Each unit should be assembled by the customer.



YHX-HD Configuration parts

Control unit

Host

Host controller unit

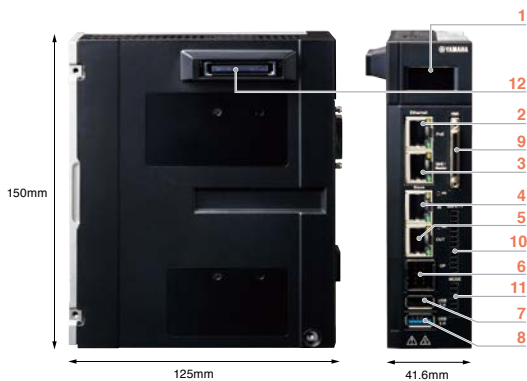

1	LCD	Indicates the status of the controller.
2	PoE	PoE compatible giga bit Ethernet connector.
3	GbE	PoE non-compatible giga bit Ethernet connector.
4	IN	LAN connector for connecting with master devices of field network communications connector (EtherNet/IP, EtherCAT, PROFINET)
5	OUT	LAN connector for connecting with other slave devices of field network communications connector (EtherNet/IP, EtherCAT, PROFINET)
6	OP	Connector for field network communications adaptors (CC-Link)
7	USB 2.0	Connector compatible with USB 2.0
8	USB 3.0	Connector compatible with USB 3.0
9	HMI	Connector for connecting with a programming pad, display and other devices
10	SAFETY	Connect with external PLC, safety devices and the like.
11	MODE	CPU OK output Programming pad AUTO/MANUAL select switch contact output
12	Connector for connection between units (control signal/Power)	

This unit can control multiple robots by combining with the linear conveyor. Although the unit is compact, it is multifunctional and has an enhanced interface.

Japanese	Model	YHX-HCU
	Parts No.	KEK-M4200-0A
English	Model	YHX-HCU-E
	Parts No.	KEK-M4200-1A



Safety connector

Host YQLink

Used for building up an external safety circuit while connecting with the safety dedicated port of a host controller.

Model	YHX-CN-SAFE
Parts No.	KEK-M4432-00



Mode connector

Host

Used for building up an external safety circuit while using the mode switch output port of a host controller unit.

Model	YHX-CN-MODE
Parts No.	KEK-M4432-10



HMI short circuit connector

Host

Used when a programming pad is not connected with a host controller. Note that if not connected, robots do not operate because the controller enters the state of emergency stop.

Model	YHX-CN-HMIS
Parts No.	KEK-M4429-00



► Power unit

D. Power

Driver power unit



This unit supplies power to each unit. Be sure to use it together with the host controller unit or a YQLink expansion unit. Use the dedicated cables to connect with linear conveyor modules.



Model	YHX-DPU
Parts No.	KEK-M5880-0A

Control power supply connector

D. Power

Used when supplying the control power supply.

Model	YHX-CN-CP
Parts No.	KEK-M4512-00



Main power supply connector

D. Power

Used when supplying the main power supply.

Model	YHX-CN-DP
Parts No.	KEK-M5382-00



Regenerative unit short circuit connector

D. Power

Used when not connecting a regenerative unit. An error is generated if the short circuit connector of a regenerative unit is not connected.

Model	YHX-CN-RUS
Parts No.	KEK-M4431-00



1	POWER	Blue: 24 VDC control power supply is available.
2	CHARGE	Orange: 200 VAC main power supply is available and Charge*
3	DC INPUT	Control power supply connector (24 VDC)
4	BATT	ABS battery connector
5	R.UNIT	Connector for connecting regenerative unit
6	AC INPUT	Main power supply connector (Single phase / 3-phase 200 to 230 VAC)
7	YQLink	YQLink communications connector Connects with IO units and linear conveyor modules.
8	⊕	Grounding terminal
9		Connector for connection between units (control signal/Power)
10		Connector for connection between units (high voltage power source for driving motors)

* Even when the main power is turned off, the lamp is lit while any charge remains in the internal capacitor. Do not touch the main circuit and motor terminal while the lamp is lit. Doing so may cause electrical shock.

Selection options

Field network

EtherCAT slave

Model	YHX-NWS-ECAT
Parts No.	KEK-M440A-A0

EtherNet/IP adapter (slave)

Model	YHX-NWS-ENIP
Parts No.	KEK-M440A-E0

PROFINET slave

Model	YHX-NWS-PFNET
Parts No.	KEK-M440A-N0

CC-Link slave (with adapter)

Model	YHX-NWS-CCL
Parts No.	KEK-M440A-C0



Connector for CC-Link

CC-Link connector

Model	YHX-CN-CCL
Parts No.	KEK-M4872-C0



CC-Link branch-out connector

Model	YHX-CN-CCSP
Parts No.	KEK-M4873-00



<Cautionary notes on field networks>

The YHX controllers are not equipped with a field network board. Entering the activation code, which is issued for each host controller, into the host controller unit enables field network functions. The activation code certificate comes with a host controller unit.

* If purchasing a field network only later on, inform us of the serial number of the host controller unit because it is necessary to issue the activation code.

* When the CC-Link option is selected, the CC-Link adapter x 1, CC-Link connector x 2, and CC-Link branch connector x 1 are supplied with the product. When the CC-Link terminating connector is needed, order it separately.

YHX controller

Programming pad (cable set)

Order model: **YHX-PP6L** (KEK-M5110-0B) 6m cable
YHX-PP12L (KEK-M5110-1B) 12m cable

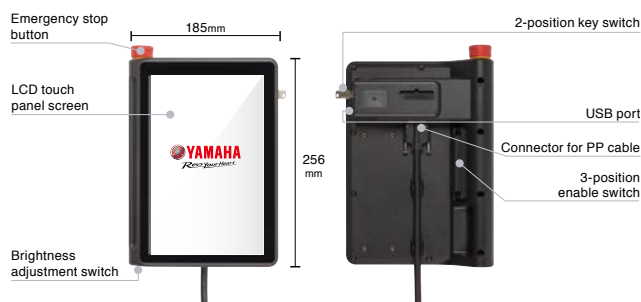

Use the touch panel screen for various operation. Equipped with safety functions (emergency stop button and enable switch) and a USB connector.



Programming pad

Model	YHX-PP
Parts No.	KEK-M5110-0A

Programming pad cable

Host		
Used when connecting a programming pad.		
6 m	Model	YHX-PP-6M
	Parts No.	KEK-M5362-61
12 m	Model	YHX-PP-12M
	Parts No.	KEK-M5362-C0



Development environment software YHX Studio for Standard Profile

Order model: **YHX-SW-STUDIO-SP** (KEK-M4990-10)

YHX Studio for Standard Profile is software that is used when the YHX host controller unit of the YAMAHA robot controller YHX series is set up.

PC operating environment	OS	Windows 7 SP1/8/8.1/10 (64-bit version only for all)
	CPU	Equivalent to Intel Core (TM) i5-6200U 2.30 GHz or better.
	Memory	8 GB or larger
	Hard disc drive capacity	2 GB or more of empty space for destination of installing the YHX Studio.
	Communications port	Ethernet
	Display	1920 × 1080 or higher resolution is recommended.
	Other	Ethernet cable (Category 5 or better)
Applicable controllers	YHX Host controller unit	
Applicable robots	Robots connectable to YHX	

Microsoft, Windows and Windows 7 are the registered trademarks or the trademarks of Microsoft Corporation in the United States. Other firms' names and product names appearing in this catalog are registered trademarks or the trademarks of the respective firms or products concerned.

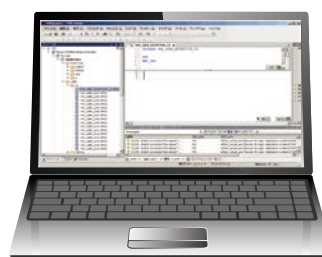

Regenerative unit set * For the required number of regenerative units, see page 67.

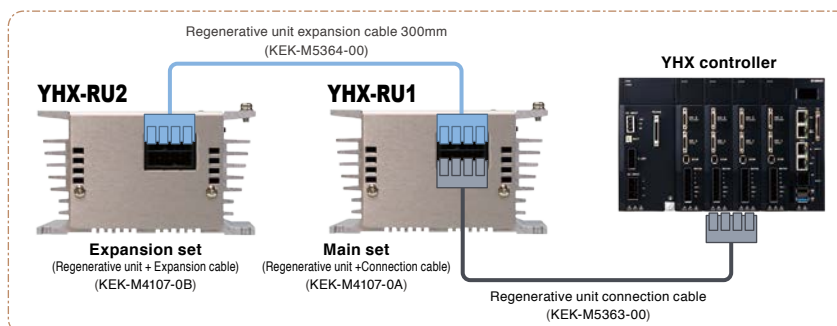

Absorbs regenerative energy generated during decelerating a robot with a large motor. Connecting two increases the capacity to absorb regenerative energy to two times.

Absorbable electric power	100 W * 200 W when 2 are connected
Momentary maximum power	1600W
Number of connected units	Maximum 2 units
Other	Forced cooling and exhaust by fan Overheat detection for protection

Regenerative unit

Regenerative unit

Regenerative unit (Main set)

Set model of regenerative unit and regenerative unit connection cable

Order model: **YHX-RU1** (KEK-M4107-0A)

Regenerative unit	
Model	YHX-RU
Parts No.	KEK-M5850-0A



Regenerative unit connection cable

D. Power Regenerative unit

Used when connecting a regenerative unit.

0.5 m	Model	YHX-RU-50C
	Parts No.	KEK-M5363-00



Regenerative unit (Expansion set)

Set model of regenerative unit and regenerative unit expansion cable

Order model: **YHX-RU2** (KEK-M4107-0B)

Regenerative unit	
Model	YHX-RU
Parts No.	KEK-M5850-0A



Regenerative unit expansion cable

Regenerative unit

Used when adding a regenerative unit.

0.3 m	Model	YHX-RU-EX30C
	Parts No.	KEK-M5364-00



YQLink expansion unit set

Order model: **YHX-YQL-SET** (KEK-M4406-0B)



1	STATUS	Blue: 24 VDC power supply available Red: Error
2	YQLink	Connect with YQLink communications connector (input) driver power unit.
3	SAFETY	Connect with external PLC, safety devices and the like.
4	Connector for connection between units (control signal/Power)	

This unit cancels the physical restrictions of the universal controller for its expansion.

YQLink

YQLink expansion unit

Model	YHX-YQL
Parts No.	KEK-M4406-0A

Safety connector

Host YQLink

Used for building up an external safety circuit while connecting with the safety dedicated port of a host controller.

Model	YHX-CN-SAFE
Parts No.	KEK-M4432-00



Other options

Battery holder box

Order model: **YHX-BATT-HLD**

D Power

Used to store the ABS batteries.
Up to eight batteries can be stored.

Model	YHX-BATT-HLD
Parts No.	KEK-M53G7-00



STOP connector

Order model: **YHX-CN-STOIN**

Drivers

Used to shut off the drive power of each driver unit.

Model	YHX-CN-STOIN
Parts No.	KEK-M5869-10



Battery holder connection cable

Order model: **YHX-BATT-15C**

D Power

Used when the battery holder box is connected.

Model	YHX-BATT-15C
Parts No.	KEK-M53G4-00



Connector for brake power

Order model: **YHX-CN-BU**

Drivers

Used when the brake power is supplied externally.
The driver is not needed when the brake power unit is used.

1 m	Model	YHX-CN-BU
	Parts No.	KEK-M4427-00



CC-Link terminating connector

Order model: **YHX-CN-CCTM**

Model	YHX-CN-CCTM
Parts No.	KEK-M4874-00



The parts with the marks below are their respective constituent parts.

Host ... Host controller unit

D Power ... Driver power unit

Regenerative unit ... Regenerative unit

YQLink ... YQLink expansion

Drivers ... Driver unit

YHX controller

Driver for single-axis robot

Order model:

Driver	Brake unit *1	ABS battery
A30:YHX-A30-SET	V: With brake unit N: None	B: With ABS battery N: None

*1: When the external brake power is input, the brake unit cannot be used.

The customer assembles the necessary number of driver units between the host controller unit and driver power unit to use them.



YHX-A30-SET Configuration parts

► Driver units

Drivers

Driver unit 30A

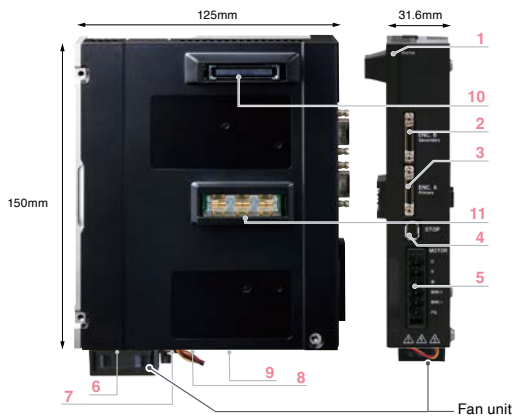

This unit drives robots. Use cables to connect with robots. The unit is connected to the left of the control unit.

30A <small>Specifications</small>	Model	YHX-A30*
	Parts No.	KEK-M5800-1C (For LCMR200/JGX)

* With fan unit



Stop short circuit connector

Drivers

Used when it is not necessary to shut off the power supply to each driver unit separately.

Model	YHX-CN-STOEN
Parts No.	KEK-M5869-00



Fan unit

Drivers

Cools down a driver unit. Attached at the bottom of a driver unit to send wind to heat sinks. A driver unit made to the 30 A specification is shipped out with a fan unit.

Model	YHX-AMP-FU
Parts No.	KEK-M6195-00



1	STATUS	Blue lamp lit: Servo ON Blue lamp flashing: Servo OFF and ready for operation Blue/Red flashing in an alternate fashion: Servo OFF and not yet ready for operation Red flashing: Error
2	ENC.B	Linear scale sensor cable connection connector dedicated for circulation unit
3	ENC.A	Connector for connecting robot cable (encoder cable)
4	STOP	Use this to build up a circuit to shut off the power to a motor. When not used, connect with the "STOP short circuit connector"
5	MOTOR	Connector for connecting robot cable (power line) - Output U/V/W current output, Brake output
6	Connector for connecting a fan	Fan unit connector
7	BATT connector	ABS battery connector
8	Power supply output for brake	Brake unit connector
9	Power supply input for holding braking effort	External power supply connector for brake unit or brake
10	Connector for connection between units (control signal/Power)	
11	Connector for connection between units (high voltage power source for driving motors)	

Selection options

ABS battery

D. Power Drivers

Model	YHX-AMP-BATT
Parts No.	KEK-M53G0-00



Brake unit

Drivers

A unit for releasing braking effort of the robot* with a brake. Enables robot brake control without an external electrical wiring. Installed at the bottom of a driver unit.

Model	YHX-AMP-BU
Parts No.	KEK-M5317-00



* Unable to release the braking effort of a robot with a brake if a brake unit is not available or if a 24 VDC power supply is not connected.

The parts with the marks below are their respective constituent parts. Host ... Host controller unit D. Power ... Driver power unit Regenerative unit ... Regenerative unit YQLink ... YQLink expansion Drivers ... Driver unit

Procedure to determine the regenerative unit quantity (Circulation unit/Traversing unit/Single-axis robot GX series)

The number of regenerative units to be connected to one **D. Power** is determined by the circulation unit and traversing unit to be operated by each **Driver** connected to that **Regenerative unit** and the configuration of the single-axis robot GX series. Check the table below for the required number of regenerative units.

Number of regenerative units required for one D. Power.

Usage configuration of single-axis robot	Number of junction axes (circulation unit and traversing unit)			
	Junction axis is not used.	Up to 2	Up to 4	5 or more
Single-axis robot is not used.	Regenerative unit is not needed.	1	2	*1
The following usage configuration ①	1	2	*1	For details, contact a YAMAHA sales representative.
The following usage configuration ②	2	*1	*1	For details, contact a YAMAHA sales representative.

*1 Add D. Power using the YQLink extension unit.

In addition, after the D. Power has been added, separate the junction axis and single-axis robot, and check the number of regenerative units required for each D. Power.

Example of selecting the required number of regenerative units

When two horizontal circulation units and four axes of the vertically installed GX20 are connected, this corresponds to *1 and add D. Power using the YQLink extension unit.

Then, separate the D. Power to which the junction axis (horizontal circulation unit) is connected and the D. Power to which the single-axis robot (GX20) is connected, and then select the number of regenerative units required for each D. Power.

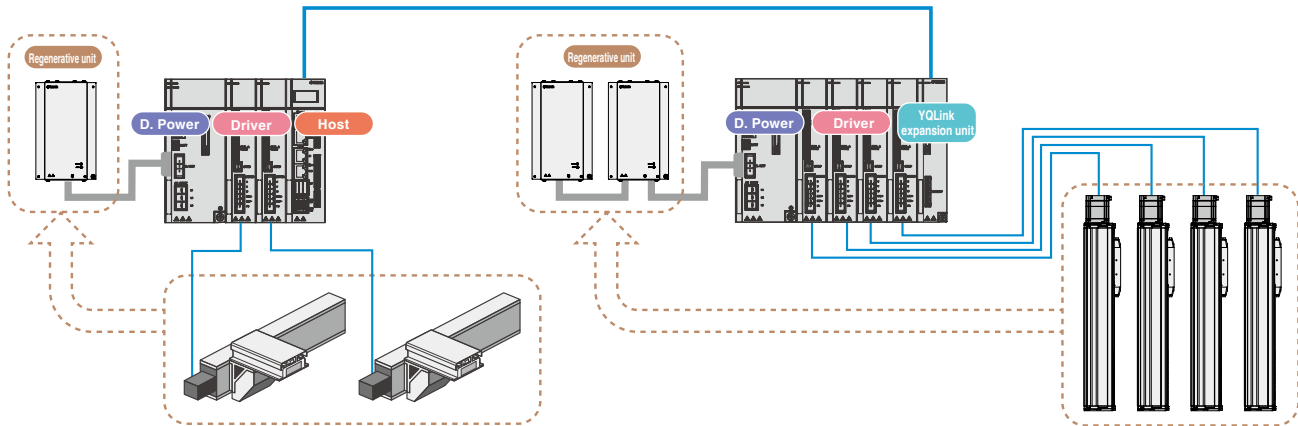

Usage configuration of single-axis robot ①

- The total motor capacity of vertically installed single-axis robots is 400 W or more.
- The vertically installed single-axis robots include the following.
 - GX07: Lead is 5 mm and stroke is 1000 mm or more.
 - GX10: Lead is 5 mm and stroke is 500 mm or more.
 - GX10: Lead is 10 mm and stroke is 500 mm or more.
 - GX10: Lead is 20 mm and stroke is 1200 mm or more.
- The horizontally installed single-axis robots include the following.
 - GX16: Lead is 20 mm and stroke is 500 to 800 mm.
 - GX20: Lead is 20 mm and stroke is 550 to 800 mm.
- The horizontally installed single-axis robots satisfy the following conditions.
 - The total number of GX12, GX16, and GX20 robots is 3 or more.
 - The total number of GX16 and GX20 robots is 2 or more.

Usage configuration of single-axis robot ②

When the single-axis robot with an operating duty (*) of 50% or more is used for 1 axis or more, two regenerative units are needed.

- The total number of vertically installed GX16 and GX20 robots is 4 axes or more.
- The total number of vertically installed GX12, GX16, and GX20 robots is 7 axes or more.
- The total number of vertically installed GX10, GX12, GX16, and GX20 robots is 8 axes or more.
- The total number of horizontally installed GX10, GX12, GX16, and GX20 robots is 6 axes or more.

* The operating duty is calculated by the following formula.

$$\text{Operating duty} = \text{Total robot movement time} \div 1 \text{ cycle time} \times 100[\%]$$

For the robot that reciprocates in one cycle, the total forward and backward movement time becomes the "total robot movement time".

YHX controller

External view of each unit

Host controller unit

YHX-HCU KEK-M4200-0A

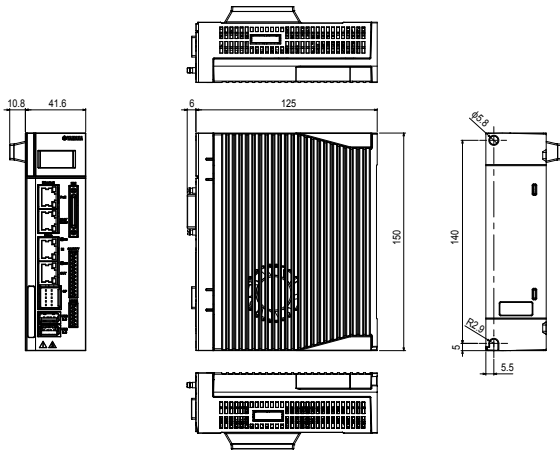

Driver power unit

YHX-DPU KEK-M5880-0A

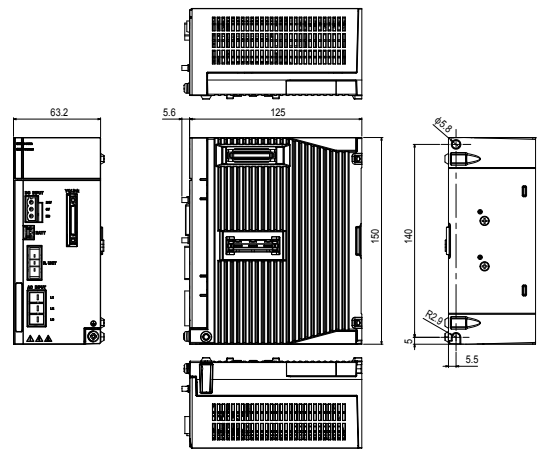

Driver unit 30A

YHX-A30 KEK-M5800-1A

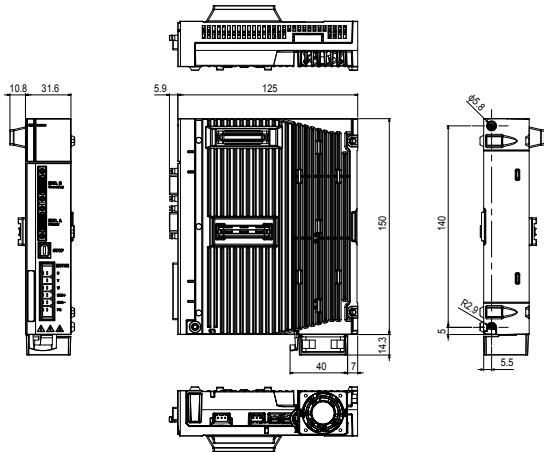

YQLink expansion unit

YHX-YQL KEK-M4406-0A

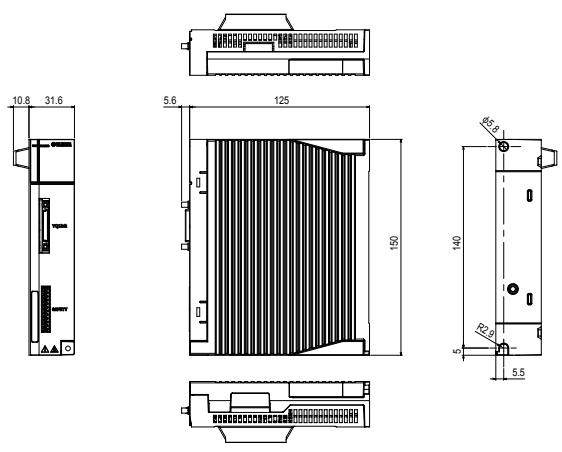

Regenerative unit

YHX-RU KEK-M5850-0A

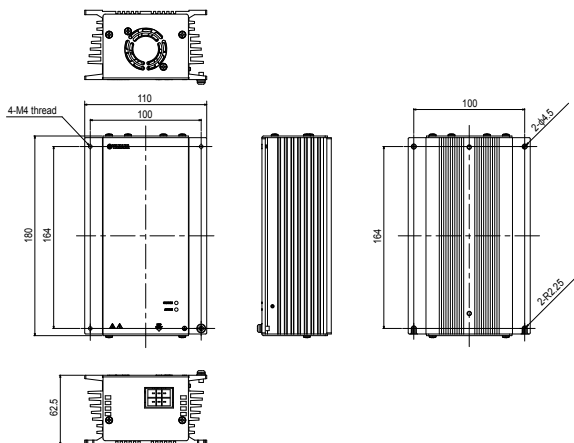

Fan unit

YHX-AMP-FU KEK-M6195-00

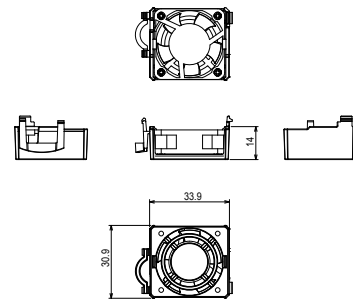

Brake unit

YHX-AMP-BU KEK-M5317-00

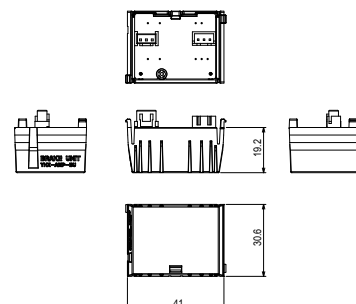

Basic specifications

Host

Host controller unit

Japanese	Model	YHX-HCU
	Parts No.	KEK-M4200-0A
English	Model	YHX-HCU- E
	Parts No.	KEK-M4200-1A

Item		Host controller unit
Power supply	Control power supply	Voltage: 21.6 to 26.4 VDC (24 V +/-10%) Current: 3.5 A (Including PoE)
	External I/F	Giga bit Ethernet · Compatible with PoE yet 1 port (23 W) · Not compatible with PoE yet 1 port Field network (Slave) Select one from the following 4 kinds. · EtherCAT · CC-Link* · EtherNet/IP · * A separate adaptor is necessary. · PROFINET
Connector		USB · USB 2.0 1 Port (Bus power 0.5 A) · USB 3.0 1 port (Bus power 1.0 A)
	HMI	Connector for connecting programming pad
	SAFETY	Emergency stop contact output Enable switch contact output Emergency stop input
	MODE	CPU OK output Programming pad AUTO/MANUAL select key switch output
Indicator	LCD	128 x 64 dots, Yellow
Dimensions		41.6×150×125 (mm)
Weight		750g
Protection structure / Protection rating		IP20 / class 1

D. power

Driver power unit

Model	YHX-DPU
Parts No.	KEK-M5880-0A

Item		Driver power unit
Power supply	Control power supply	Voltage: 21.6 to 26.4 VDC (24 V +/-10%) Current: 0.5A
	Main power supply	Input: Single phase / 3-phase 180 to 253 VAC / (200 to 230 VAC +/-10%), 50/60 Hz Power supply capacity: Single phase 3.5 kVA 3-phase 6 kVA
Connection motor capacity		Single phase within 1.6 kW, 3-phase within 3.0kW / Driver unit within 16 units (16 axes)
Connector	Regenerative	Regenerative unit connector
	External I/F	YQLink
	ABS Battery	ABS Battery connector
Dimensions		63.2×150×125 (mm)
Weight		1050g
Protection structure / Protection rating		IP20 / class 1

Regenerative unit

Regenerative unit

Model	YHX-RU
Parts No.	KEK-M5850-0A

Item		Regenerative unit
Power supply	Input	254 to 357 VDC (Controller DCBUS connected)
Connector		Regenerative connector (For connecting regenerative unit/ For adding regenerative unit)
Dimensions		62.5×180×110 (mm)
Weight		1450g
Protection structure / Protection rating		IP20 / class 1

YQLink

YQLink expansion unit

Model	YHX-YQL
Parts No.	KEK-M4406-0A

Item		YQLink expansion unit
Power supply	Control power supply	Voltage: 21.6 to 26.4 VDC (24 V +/-10%) Current: 0.3A
	External I/F	YQLink
Connector	SAFETY	Emergency stop input
Dimensions		31.6×150×125 (mm)
Weight		380g
Protection structure / Protection rating		IP20 / class 1

Driver

Driver unit

Servo motor specifications (30A)

Model	YHX-A30
Parts No.	KEK-M5800-1A

Item		Driver unit 30 A
Power supply	Control power supply	Voltage: 21.6 to 26.4 VDC (24 V +/-10%) Current: 0.8A (Including brake unit power supply)
	ENC.A	Encoder input
Connector	ENC.B	Encoder input (Dedicated use)
	STOP	Gate off input, 2 points Gate status output, 1 point
	MOTOR	Motor drive power supply output Brake power supply output
	ABS Battery	ABS Battery connector
	Fan unit connector	Accessory fan unit connection
	Brake unit connector	Brake unit is connectable.
Dimensions		31.6×150×125 (mm)
Weight		570 g
Protection structure / Protection rating		IP20 / class 1

YHX controller

External view of YHX unit combination

Combination of host controller (HCU), driver unit (A30), and driver power unit (DPU)

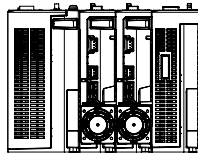
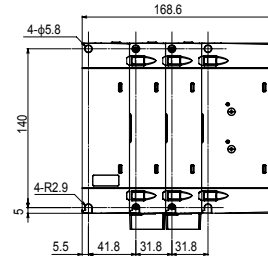
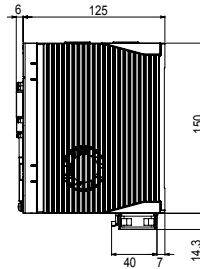
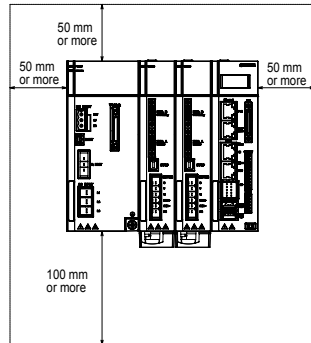
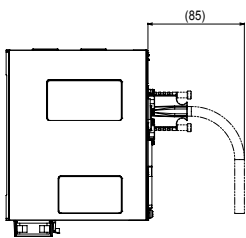
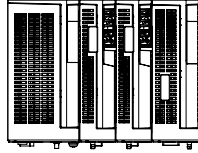
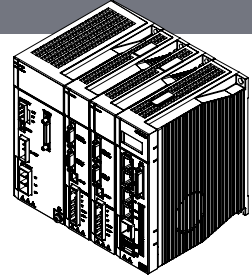

Combination of host controller (HCU) and driver power unit (DPU)

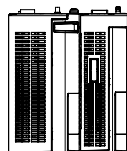
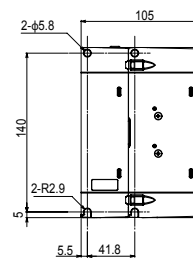
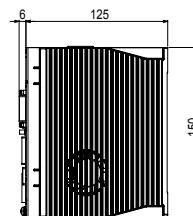
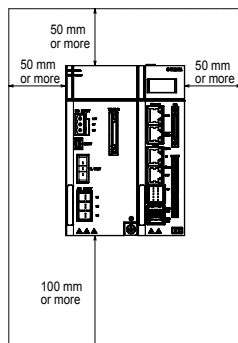
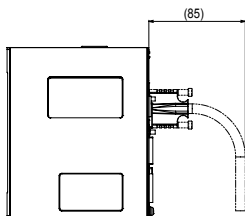
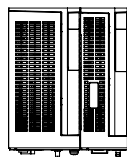
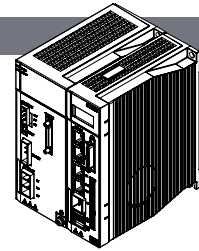



Safety Precautions

Read the instruction manual thoroughly to operate the robot in a correct manner.



YAMAHA

YAMAHA MOTOR CO., LTD.

Robotics Operations
Sales & Marketing Section
FA Sales & Marketing Division

127 Toyooka, Chuo-Ku, Hamamatsu, Shizuoka 433-8103, Japan
Tel. +81-53-525-8350 Fax. +81-53-525-8378

URL <https://global.yamaha-motor.com/business/robot/>

● Specifications and appearance are subject to change without prior notice.