





LINEAR MOTOR DRIVE

-  RAIL GUIDE
-  HIGH DYNAMICS
-  HIGH REPEAT ACCURACY
-  LONG TRAVERSE PATH
-  INDEPENDENT CARRIAGES

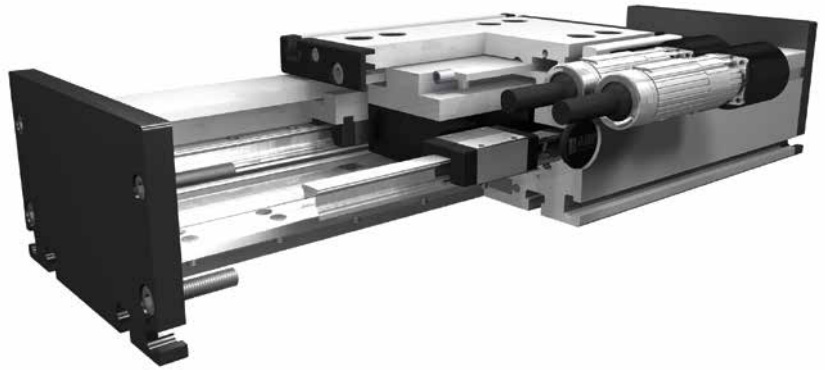

Function:

This unit consists of a rectangular aluminium profile with 2 integrated rail guidance. The linear motor DSM unit is based on the principle of a linear, synchronous AC motor. The guiding profile is fitted with permanent magnets as stator (secondary part). The carriage is fitted with the actuator (primary part). The magnetic attraction causes a force between carriage and guiding profile also in the absence of current. This force can be used for the initial tension of the bearings. Several carriages (primary parts) can be driven independently on one guiding profile.

Fitting position:

As required. Max. length 6.000 mm without joints.

Carriage mounting:

By T-slots.

Unit mounting:

By T-slots and mounting sets. The linear axis can be combined with any T-slot profile.

Carriage support:

In the standard version, the carriage runs on 4 runner blocks which can be serviced at a central servicing position. For longer carriages the number of runner blocks can be increased.

Repeatability $\pm 0,05$ mm mm. Repeated accuracy max. $\pm 0,05$ mm bis 4.000 mm, $\pm 0,1 >4.000$ mm.

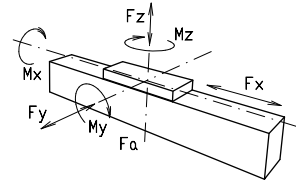
Forces and torques	Size	120		160			200			
	Motor size	1	2	1	2	3	1	2	3	
 <p> F_z = external force by load F_a = magnetic attraction force F_{zm} = maximum force in consideration of motor power $F_{zm} = F_z + F_a$ </p>	permitted dyn.Forces*	10000 km		10000 km			10000 km			
	F_z (N)	600	1200	1200	1800	5500	3600	5500	11000	
	F_{zm} (N)	820	1640	1590	2800	7030	4990	7640	13860	
	F_x (N)	650	500	1775	1775	3550	4092	4092	8184	
	M_x (Nm)	35	32	160	128	153	357	231	462	
	M_y (Nm)	40	58	373	351	532	769	556	1540	
	M_z (Nm)	40	57	222	261	328	585	654	906	
	Number of runner blocks	6	8	4	4	8	4	4	8	
	All forces and torques related to the following: existing values $\frac{F_y}{F_{y_{dyn}}} + \frac{F_{zm}}{F_{zm_{dyn}}} + \frac{M_x}{M_{x_{dyn}}} + \frac{M_y}{M_{y_{dyn}}} + \frac{M_z}{M_{z_{dyn}}} \leq 1,5$ table values									
	Motor specifications F_x									
Motor size	1	2	1	2	3	1	2	3		
Carriage weight (kg)	1,4	2,7	4,8	5,3	7,1	10,9	11,4	16,9		
Weight primary part (kg)	0,7	1,4	1,4	3,7	5,2	4,5	6,4	8,4		
permanent (N)	61	115	115	271	406	383	574	766		
Max. (N) 1s	162	323	323	607	911	868	1301	1735		
Moving force without current										
N	15	15	30	30	60	40	40	80		
Geometrical moments of inertia of aluminium profile										
I_x mm ⁴	5,60 x10 ⁵		2,13 x10 ⁶			4,81 x10 ⁶				
I_y mm ⁴	34,19 x10 ⁵		12,3 x10 ⁶			26,0 x10 ⁶				
Elastic modulus N/mm ²	70000		70000			70000				

For life-time calculation use our homepage.

* referred to life-time

Deflection:

$$f = \frac{F \cdot L^3}{E \cdot I \cdot 192}$$

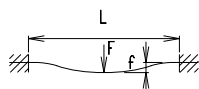

- f = deflection (mm)
- F = load (N)
- L = free length (mm)
- E = elastic modulus 70000 (N/mm²)
- I = second moment of area (mm⁴)

Linear system **DSM 120, 160, 200**

Dimensions (mm)

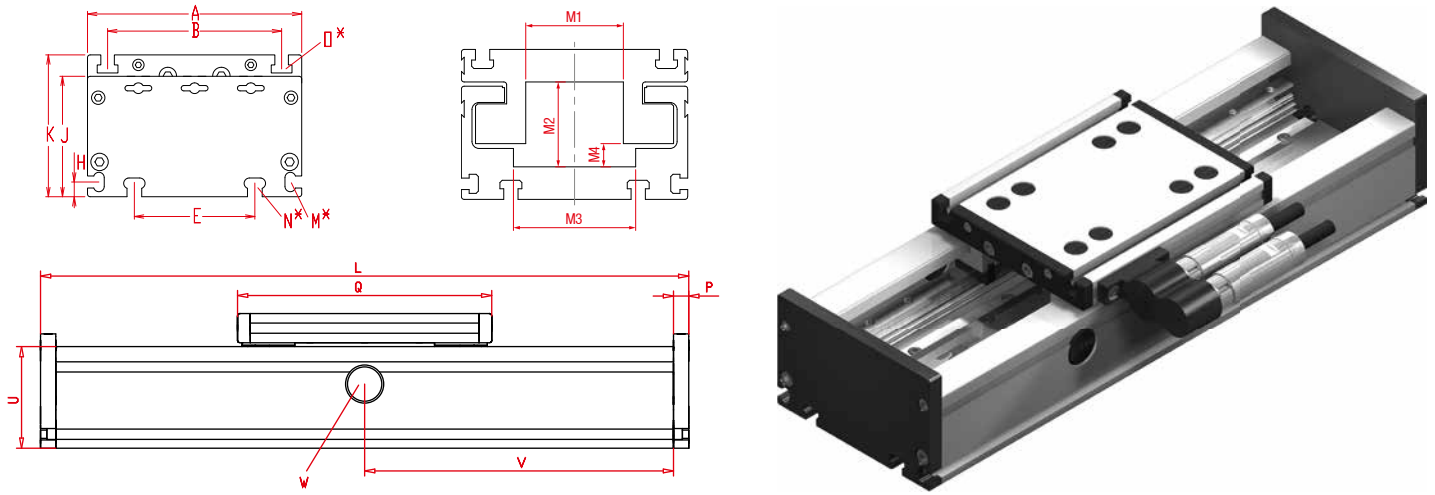

$V = Q + 100 \text{ mm}$

W = servicing position

Increasing the carriage length will increase the basic length by the same amount.

Size	Basic length L	A	B	E	H	J	K	M for	N for	O for	P	U	Basic weight Motor size 1/2/3	Weight per 100 mm Motor size 1/2/3
DSM 120	Q + 30	120	96	78	10	68	79	M 5	M 6	M 6	10	60	4,8/6,9 kg	1,0/1,0
DSM 160	Q + 30	160	130	90	11	90	106	M 6	M 8	M 8	12	80	12,4/16,7/22,6 kg	1,7/2,0/2,0 kg
DSM 200	Q + 35	200	160	140	15	110	129	M 8	M 10	M 10	15	100	30,0/33,0/44,2kg	3,1/3,1/3,1 kg

0 Choice of guide body profile: Stainless versions upon request.

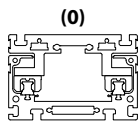

without internal profile and cover bands

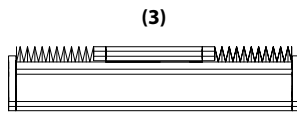

with bellows

Size	M1	M2	M3	M4
DS 120	52	45	64	13
DS 160	70	60	85	17
DS 200	84	77	100	15

Helper table for provided motors

1 Measurement system:

- (1) Measurement system LE100 5V Resolution 0.05
- (2) Measurement system LE100 10,5-30V Resolution 0.05
- (3) Hall sensor
- (4) Measurement system provided by customer

1 Plug:

- (1) Plug Pos. 1
- (2) Plug Pos. 2
- (3) open unconnected cable end

1 Motor size:

- (1) Motor size 1 with Q_1
- (2) Motor size 2 with Q_2
- (3) Motor size 3 with Q_3
- (4) Supply with Q_1^*
- (5) Supply with Q_2^*
- (6) Supply with Q_3^*

* = provided by customer

Dimensioning criteria for motor output						
	l_p	b_p	h_{ps}	Q_1	Q_2	Q_3
120	Q - 70	55	38	196	276	-
160	Q - 70	71	50	316	360	461
200	Q - 70	85	62	410	444	610

l_p = length primary part; b_p = width primary part;
 h_{ps} = height primary part + height secondary part + interspaces primary-/secondary part

For standard carriage length see 'Q' in table.

The carriages can be delivered in any non-standard length upon request; the longer the carriage, the greater the load capacity. For linear encoder refer to chapter 9.1.

DSM 160 0 0 1 1 0 0 1 1500

Basic length + stroke = total length

Pos. 1 2 3 4 5 6 7

Sample ordering code:

DSM160, Bahr Modultechnik Linear motor, standard body profile, Measurement system LE100 5V, Plug Pos. 1, motor size 1, 1154 mm stroke

