

BELT DRIVE

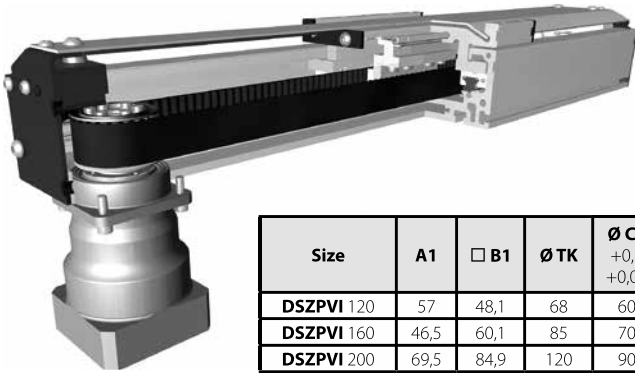
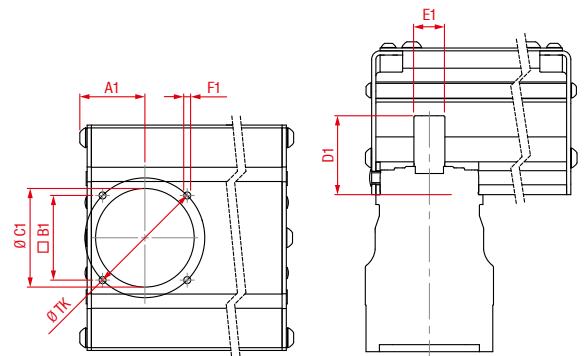

Size	A1	□ B1	Ø TK	Ø C1 +0,1 +0,05	D1	E1	F1
DSZPVI 120	57	48,1	68	60	48	16	M5
DSZPVI 160	46,5	60,1	85	70	56	22	M6
DSZPVI 200	69,5	84,9	120	90	88	32	M8

**Function:**

This unit consists of a rectangular aluminium profile with 2 integrated rail guides. The carriage is moved by a belt drive. On the drive side the pulley is beared on the shaft of a planetary gear. Belt tension can be readjusted by a simple screw adjustment at the opposite side of the drive. A special curved aluminium sheet is covering the carriage side. There is only a small gap between carriage and aluminium sheet. Because of its special design it is possible to drive the carriage over the pulley areas. This fact is making the unit very compact.

Fitting position:

As required, max. length DSZPVI 120 / 1600mm, DSZPVI 160 / 1800mm, DSZPVI 200 / 2000mm

Carriage mounting:

By tapped holes.

Unit mounting:

T-slots

Belt type:

HTD with steel reinforcement, no backlash when changing direction, repeatability $\pm 0,1$ mm.

Carriage support:

In the standard version, the carriage runs on 4 runner blocks which can be serviced at a central servicing position. For longer carriages the number of runner blocks can be increased.

Forces and torques	Size	120		160		200	
	permitted dyn. Forces*	5000 km	10000 km	5000 km	10000 km	5000 km	10000 km
F_x (N)	894	800	1900	1800	4000	3800	
F_y (N)	1776	1405	5570	3900	15600	11080	
F_z (N)	2090	1650	7050	5020	20600	14600	
M_x (Nm)	81	64	358	255	1285	915	
M_y (Nm)	97	77	369	262	1375	980	
M_z (Nm)	96	76	364	258	1345	960	
All forces and torques related to the following:							
existing values $\frac{F_y}{F_{y_{dyn}}} + \frac{F_z}{F_{z_{dyn}}} + \frac{M_x}{M_{x_{dyn}}} + \frac{M_y}{M_{y_{dyn}}} + \frac{M_z}{M_{z_{dyn}}} \leq 1$							
table values $\frac{F_y}{F_{y_{dyn}}} + \frac{F_z}{F_{z_{dyn}}} + \frac{M_x}{M_{x_{dyn}}} + \frac{M_y}{M_{y_{dyn}}} + \frac{M_z}{M_{z_{dyn}}} \leq 1$							
No-load torque							
Nm without cover bands		1,2		1,5		2,0	
Speed							
(m/s) max		5		5		5	
Tensile force							
permanent (N)		900		1900		4000	
0,2 s (N)		1000		2090		4300	
Geometrical moments of inertia of aluminium profile							
I_x mm ⁴		5,61x10 ⁵		2,32 x 10 ⁵		48,07 x 10 ⁵	
I_y mm ⁴		34,19x10 ⁵		123,36 x 10 ⁵		259,99 x 10 ⁵	
Elastic modulus N/mm ²		70000		70000		70000	

For life-time calculation use our homepage.

* referred to life-time

Driving torque:

$$M_o = \frac{F \cdot P \cdot S_i}{2000 \cdot \pi} + M_n$$

$$P_o = \frac{M_o \cdot n}{9550}$$

F = force (N)
P = pulley action perimeter (mm)
S_i = safety factor 1,2 ... 2
M_n = no-load torque (Nm)
n = rpm pulley (min⁻¹)
M_o = driving torque (Nm)
P_o = motor power (KW)

Deflection:

$$f = \frac{F \cdot L^3}{E \cdot I \cdot 192}$$

f = deflection (mm)
F = load (N)
L = free length (mm)
E = elastic modulus 70000 (N/mm²)
I = second moment of area (mm⁴)

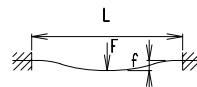

Linear system **DSZPVI 120, 160, 200**

Dimensions (mm)

Increasing the carriage length will increase the basic length by the same amount.

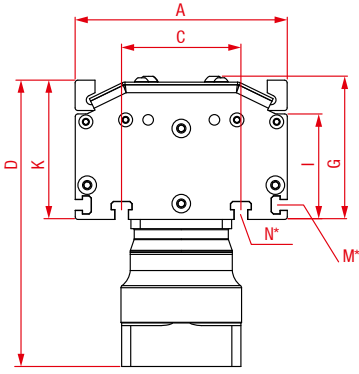

Optionally available with angular planetary gearbox

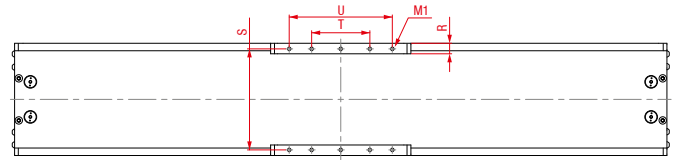
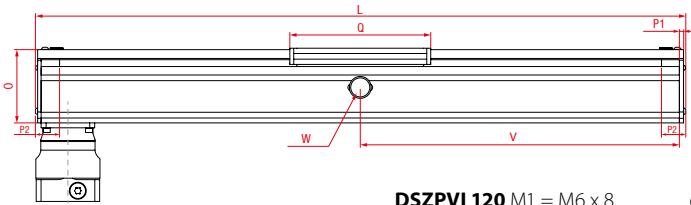

DSZPVI 120 M1 = M6 x 8 only 8 threaded holes in the carriage

DSZPVI 160 M1 = M8 x 12 **DSZPVI 200** M1 = M10 x 12

W = servicing position

Size	Basic length L	A	C	D	G	I	K	M for	N for	O	P1	P2	Q	R	S	T	U	Basic weight without gearbox	Weight per 100 mm
DSZPVI 120	225	120	78	169	82,5	60	79,5	M5	M6	78	6	35	152	11,5	106	40	120	3,45 kg	0,87 kg
DSZPVI 160	285	160	90	217,5	108,5	80	106	M6	M8	104	8,25	43,5	196	15	144	80	160	10,27 kg	1,55 kg
DSZPVI 200	350	200	140	251	132,5	100	129	M8	M10	128	10	45,5	248	17	180	100	200	18,20 kg	2,14 kg

0 Choice of guide body profile: Stainless versions upon request.

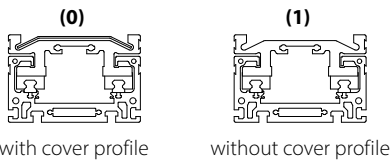

with cover profile

without cover profile

0 Choice of carriages:

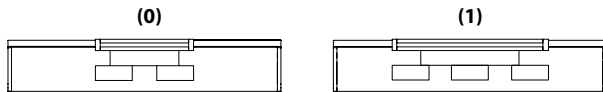

Size	Version 1	
	Q	L
120	>152	>225
160	>228	>330
200	>290	>430

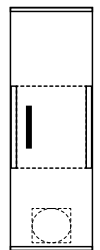

belt connection

0 Drive version:

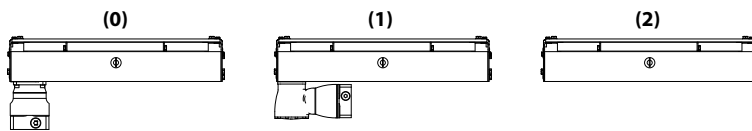

- (0) planetary gearbox
- (1) angular planetary gearbox
- (2) without gearbox

Belt table:

Code-No.	Size	Belt	mm/rev.	Number of teeth
0 4	120	5M25	130	26
0 7	160	8M30	176	22
0 9	200	8M50	224	28

Gearbox variants:

Gearbox	DSZPVI 120	DSZPVI 160	DSZPVI 200
Neugart	(0) PLN 70 (1) WPLN 70	PLN 90 WPLN 90	PLN 115 WPLN 115
SEW	(0) PSKC 221	PSKC 321	PSKC 521
Wittenstein	(0) SP+060 (1) SK+060	SP+075 SK+075	SP+100 SK+100

DSZPVI 160 1 0 0 0 0 7 1 1500

Basic length + stroke = total length

Pos. 1 2 3 4 5 6 7

Sample ordering code:
DSZPVI 160 with cover profile, standard carriage, with planetary gearbox, 1202 mm stroke.



Our policy is one of continued research and development. We therefore reserve the right to amend, without notice, the specifications given in this document. © 2023 Bahr Modultechnik GmbH

Linear system **DSZPVI 120, 160, 200**

BELT DRIVE, WITH TWO DRIVEN CARRIAGES

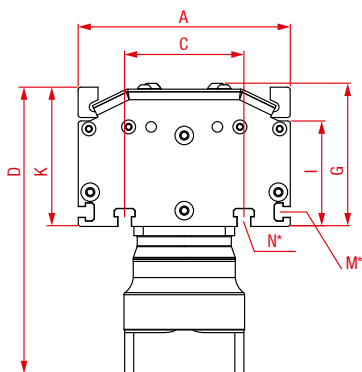

Increasing the carriage length will increase the basic length by the same amount.

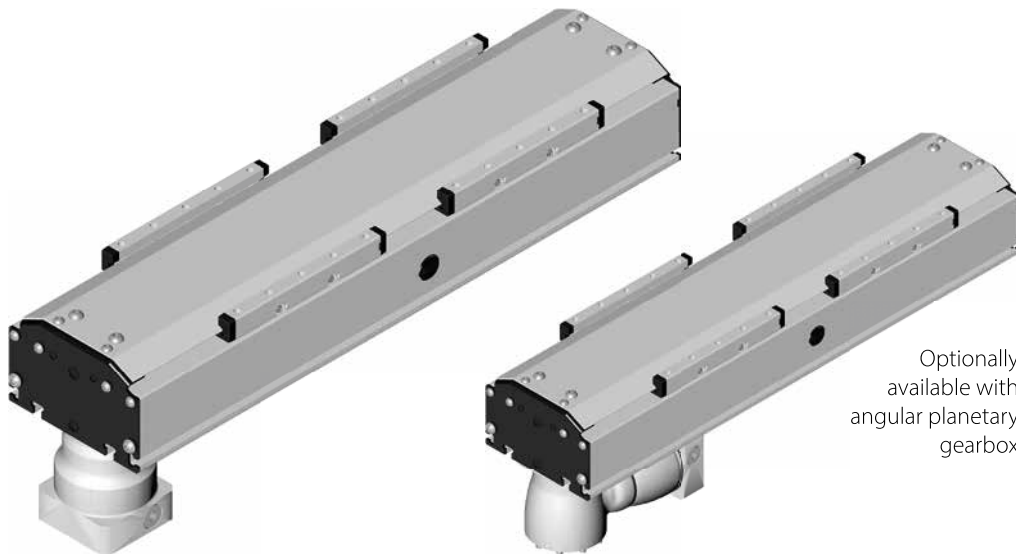

Optionally available with angular planetary gearbox

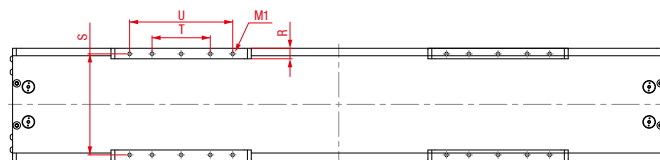
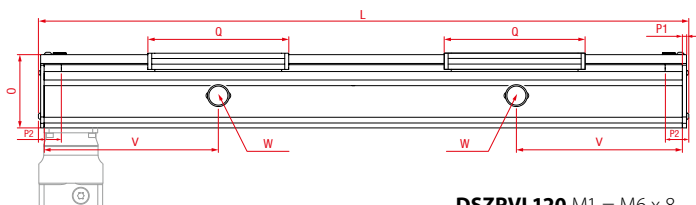

DSZPVI 120 M1 = M6 x 8

only 8 threaded holes in the carriage

DSZPVI 160 M1 = M8 x 12 **DSZPVI 200** M1 = M10 x 12

$V = Q + 100$

W = servicing position

Size	Basic length L	A	C	D	G	I	K	M for	N for	O	P1	P2	Q	R	S	T	U	Basic weight without gearbox	Weight per 100 mm
DSZPVI 120	380	120	78	169	82,5	60	79	M5	M6	78	2	35	152	11,5	106	40	120	4,3 kg	0,9 kg
DSZPVI 160	485	160	90	217,5	108,5	80	106	M6	M8	104	3	43,5	196	15	144	80	160	12,1 kg	2,3 kg
DSZPVI 200	600	200	140	251	132,5	100	129	M8	M10	128	3	45,5	248	17	180	100	200	22,1 kg	3,2 kg

0 Choice of guide body profile: Stainless versions upon request.

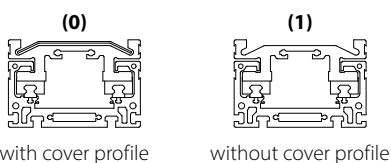

Baugröße	Ausführung 1	
	Q	L
120	>152	>380
160	>228	>549
200	>290	>684



belt connection

0 Choice of carriages:

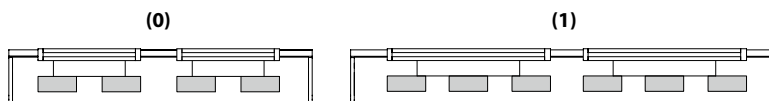

0 Drive version:

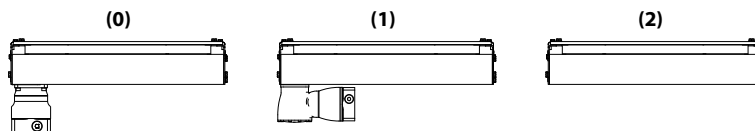

- (0) planetary gearbox
- (1) angular planetary gearbox
- (2) without gearbox

Belt table:

Code-No.	Size	Belt	mm/rev.	Number of teeth
0 4	120	5M25	130	26
0 7	160	8M30	176	22
0 9	200	8M50	224	28

Gearbox variants:

Gearbox	DSZPVI 120	DSZPVI 160	DSZPVI 200
Neugart	(0) PLN 70 (1) WPLN 70	PLN 90 WPLN 90	PLN 115 WPLN 115
SEW	(0) PSKC 221	PSKC 321	PSKC 521
Wittenstein	(0) SP+060 (1) SK+060	SP+075 SK+075	SP+100 SK+100

DSZPVI 160 1 0 0 0 0 7 1 1500

Basic length + stroke = total length

Pos. 1 2 3 4 5 6 7

Sample ordering code:

DSZPVI 160, right - left version, with cover profile, standard carriage, with planetary gearbox, 1015 mm stroke