

MDX+ SERIES

INTEGRATED SERVO MOTOR
DRIVE + MOTOR + CONTROLLER



EtherCAT  CANopen  Modbus 

Note: EtherCAT® is a registered trademark, licensed by Beckhoff Automation GmbH.

MDX+ Integrated Servo Motor

Product overview

The MDX+ series is a family of low-voltage servo systems that integrate a servo drive, servo motor and encoder into one package. Solutions with power output of 100/200/400/550W are available. The MDX+ product line supports pulse train based control methods (Pulse&Dir, CW/CCW, encoder following), RS-485, CANopen and EtherCAT. It also offers packages with electromagnetic brakes and STO to meet the safety requirement of today's industries. The MDX+ series is an ideal solution for manufacturers in logistics, AGV, medical, semiconductor and solar industries among many others.

The MDX+ servo drive is debugged by Luna software. It is meant to assist users with configuration, tuning and troubleshooting of the MDX+ family. The software and the drive are connected via USB for fast and reliable communication.

Features

- Drive and motor integration offers a compact design
- Main power supports 24-60 VDC, Auxiliary power supports 24 VDC
- Standardized frame sizes of 40/60/80mm, covering a power range 100W to 550W
- EtherCAT, CANopen and RS-485 options
- Equipped with 17-bit magnetic incremental encoder or 17-bit batteryless absolute encoder
- Accurate Positioning and Control
- Support position control, velocity control, torque control
- Built-in brake option is available
- IP20 or IP65 options available

Applications

MDX+ series integrated servo motors have a wide range of applications:

Packaging

Logistics

Material Inspection

Public Space

AGV

Electronic components

Medical

Textile

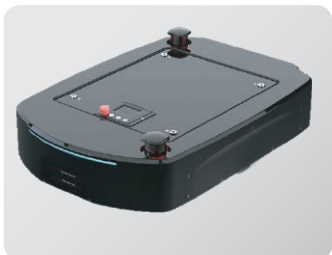

Features

■ Compact Design

MDX+ series is designed to be small and compact, providing a smaller, yet equally capable solution when compared to stand-alone motor and drive systems. The MDX+ series is ideal for applications with limited installation space with its form factor that is at least 20% smaller than that of standalone solutions.

Less components
and
easier wiring



Replace this...

With this...

all in
ONE

Motor
Encoder
Drive
Industrial Fieldbus



Smaller control panel, **Simpler** installation, **Easier** configuration

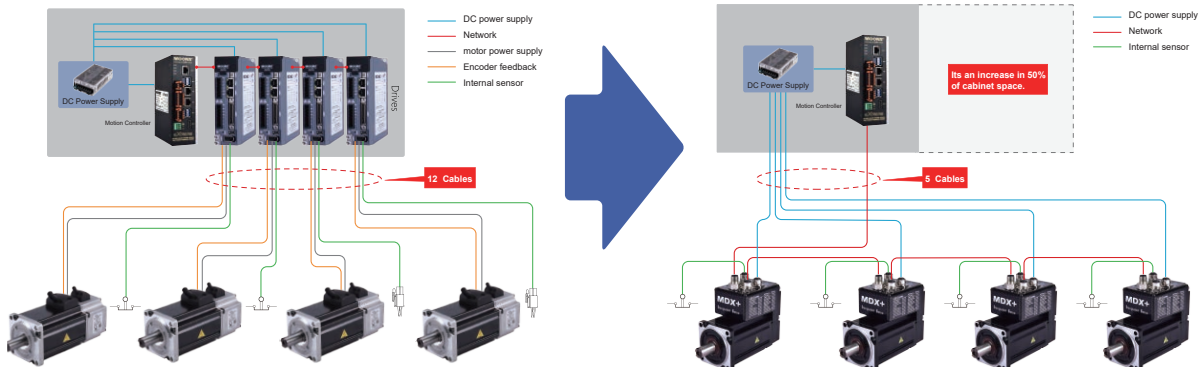

■ Safe Operation

● STO

Safe Torque Off (STO) is a hardware level safety protection function. When the STO function is activated, the ability to drive motor current is cut-off. In case of an emergency, this function can increase human and equipment safety while the drive is continuously powered.

MDX+ series drive meets UL61800-5-2(SIL 3), IEC61508, ISO138491(PL e).

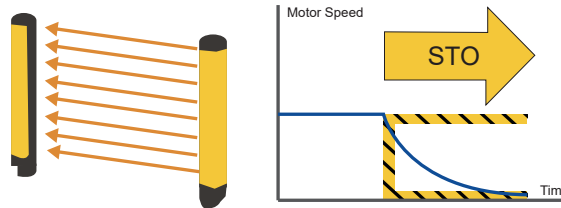

● Dynamic Brake

Dynamic brake is a mechanism that stops the motor with the fastest speed by shorting the motor three-phase in case of an emergency, the intention is to protect the safety of equipment and surrounding. Dynamic brake is driven by motor's back EMF current, no external power source is needed to engage or disengage the brake function.

The following graphs show what emergency induced stops, when a fault is present, behave like without and with dynamic braking.

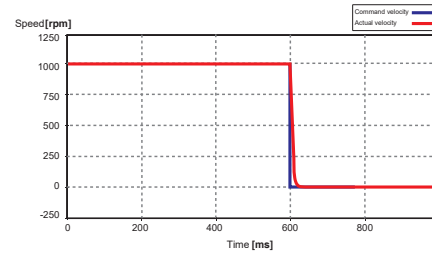
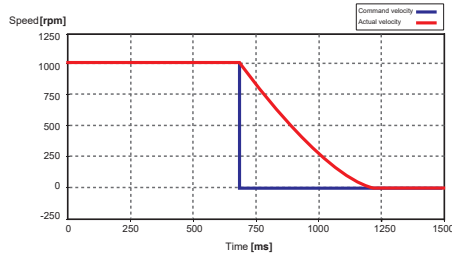

Without Dynamic brake

The motor is disabled and decelerates in an uncontrolled manner. The deceleration time and distance are determined by the system inertia and friction.

With Dynamic Brake

The velocity command is set to 0 as soon as the drive is disabled. The actual velocity ramps down immediately as the brake is applied.

● Emergency Stop

- ◆ When the communication between the controller and drive fails during motion, the drive will trigger the watchdog function which will decelerate the motor according to the preset rate and mode.
- ◆ I/O functions and field bus control commands can be used to stop a motor in an emergency situation. The motor will stop with the method and deceleration rate configured by the customer.

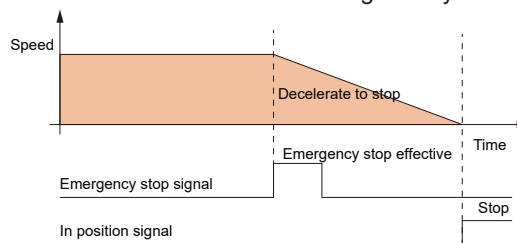

● Protective Functions



Over voltage protection



Over current protection



Over temperature protection

Waterproof and Dustproof

MDX+ series integrated servo motors are available with IP65 rating. See Part Numbering System for model selection.



High Positioning Accuracy

Combining a high resolution encoder design with low cogging characteristics, the MDX+ product line provides the ultimate smooth and accurate positioning experience.

- ◆ 17-bit incremental/absolute magnetic encoder with up to 131,072 feedback pulses per revolution
- ◆ Battery-less absolute encoder option to ensure position storage despite power cycles.

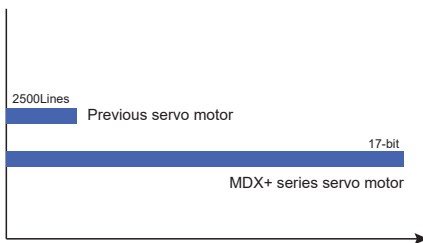

300% Peak Torque Capable

- ◆ Peak torque values of up to 300%, providing higher acceleration and deceleration rates.
- ◆ MDX+ Series 550W models can provide peak torque of up to 400% of rated torque.

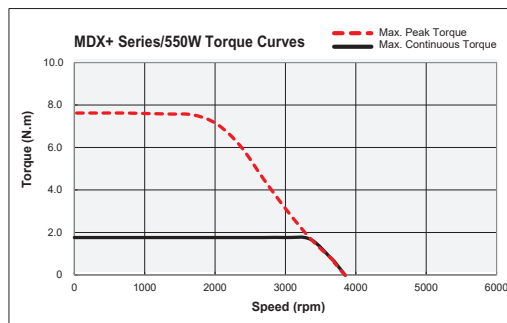
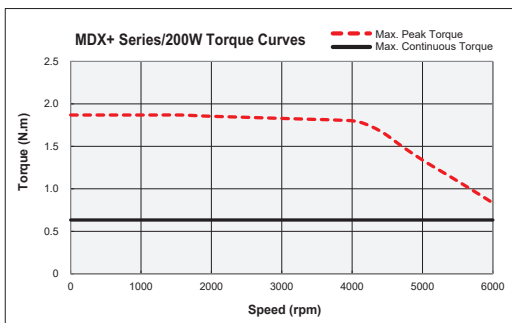

Easy Tuning

Tuning-less Function

- ◆ No tuning is required for load up 30 times load inertia ratio.
- ◆ No limitation towards any load type and drive control mode.
- ◆ High robustness for maximum control of servo system stability.

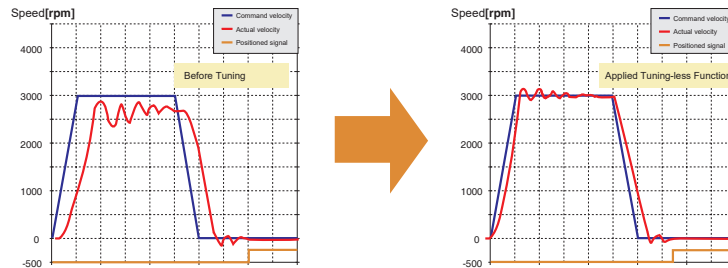

Auto-tuning

The real-time auto-tuning algorithm can automatically identify the load inertia (ratio), gain and vibration suppression parameters in real time.

The auto-tuning function can greatly shorten your system tuning time, improve system responsiveness and equipment production efficiency.

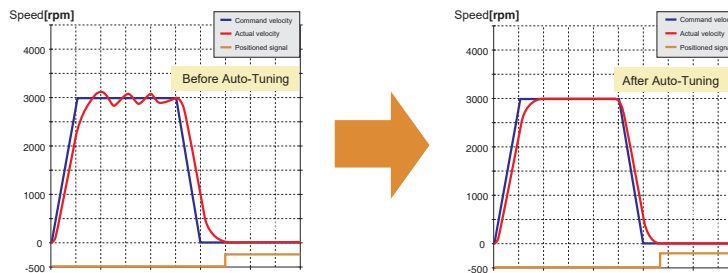

Unique Q programming function

Q Programmer is MOONS' own single-axis motion control software based on SCL commands. It can be used to create sophisticated and functional programs that can be saved to a drive's nonvolatile memory, and then run stand-alone, or without a permanent connection to the host. Q drives offer a high level of flexibility and functionality to the machine designer and system integrator.

Capabilities:

- Motion control commands (relative position, absolute position, homing mode, etc.)
- Multi-Tasking (execution of subsequent commands while motion profile is executed)
- Conditional Processing (based on external I/O or internal commands)
- Math Functions (+, -, *, /, &, or)
- Data register manipulation
- Program order of execution (loops, function calls, jumps)

Line	Label	Cmd	Param1	Param2	Comment
1		MT	1		Turn ON Multi-Tasking
2		DL	3		Turn OFF limits
3		PF	2000		Set Position Fault limit
4		CC	2		Set continuous current to 50%
5		CP	2		Also set peak current to same
6		DI	4000		Make distance positive for CW
7		JM	1		Set Jog mode to positioning
8		JS	1		Set Jog speed to 1 rev/sec
9		JA	10		Set Jog accel to 10 rev/sec/sec
10		CJ			Start jogging
11	Label2	TR	x	100	Test Reg "x" against 100
12		QJ	G	#Label1	Jump if greater than
13		TR	x	-100	Test Reg "x" against -100
14		QJ	G	#Label2	Jump if greater than
15	Label1	SM	M		Stop move with max accel (AM)
16		WM			Wait for stop to complete
17		EP	0		Set encoder position to zero
18		VE	1		Set Velocity to 1 rev/sec
19		DI	-8000		Set home offset distance (CCW)
20		FL			Do a Relative move
21		WM			Wait for move to complete
22		SP	0		Set absolute position to zero
23		AX			Clear any faults just in case
24		WT	0.1		Wait 0.1 seconds

Field-bus Options

There are many applications based on fieldbus communication in industrial automation. The MDX+ series servo system can support EtherCAT, RS-485 (including Modbus RTU), and CANopen.

CANopen

Standard CAN bus interface is available in MDX+ series servo drives, which makes it easy to get integrated into an existing CANopen network.

Items	Specification
Physical Layer Standard	CiA 303-1 Cabling and connector pin assignment
Communication Protocol	CiA 301 Application Layer and Communication Profile CiA 402 Device Profile Drives and Motion Control
Bus Connector	Molex
Baud Rate	12.5Kbps, 20Kbps, 50Kbps, 125Kbps, 250Kbps, 500Kbps, 800Kbps, 1Mbps
Communication Objects	SDO, PDO, SYNC, EMCY, NMT, Heartbeat
Control Mode	Interpolated Position, Profile Position, Profile Velocity, Profile Torque, Homing Mode
PDO Data	4 RxPDOs, 4 TxPDOs
Support Axis	Up to 112 axes

Modbus

MDX+ series servo drives provide the Modbus/RTU communication function with RS-485 interface, which can be used to easily control the motor, set parameters or monitor the status of the drive.

Items	Specifications
Physical Layer Standard	RS-485
Communication Protocol	Modbus/RTU
Bus Connector	Molex
Baud Rate	9600bps, 19200bps, 38400bps, 57600bps, 115200bps
Control Mode	Position Mode, Velocity Mode, Torque Mode, Homing Mode, Q Program
Support Axis	Up to 32 axes

EtherCAT

- Full duplex, communication baud rate 100Mbps
- Supports CoE(CiA 402 protocol), VoE(Vendor over EtherCAT)
- Supports PP, PV, TQ, CSP, CSV, CST, HM mode

MOONS' has a variety of EtherCAT capable product lines that can meet all of our user's needs.



■ Friendly Software

● USB Multi-axis Tuning

Based on USB communication, it can realize multi-axis tuning, simple and convenient.

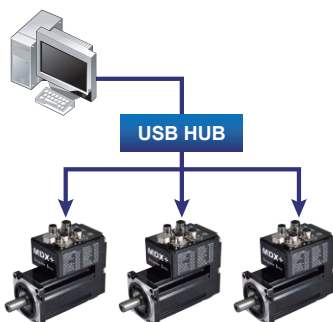

● Graphical Setting Interface

Descriptive and clear visual aids help configure necessary functions.

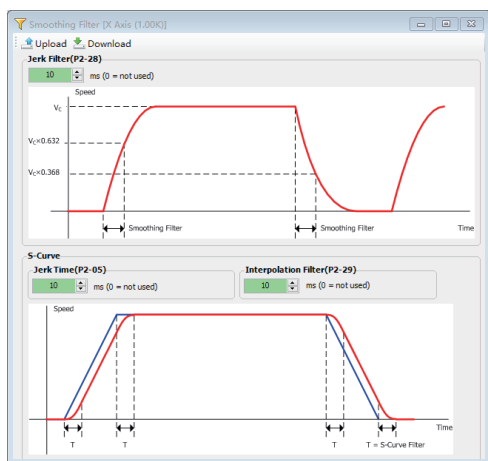

● Powerful Oscilloscope Function

- Real-time data curve display
- Up to 4 channels with 16bit data per channel and 8kHz sampling rate
- Up to 2 channels with 32bit data per channel and 8kHz sampling rate
- In the selected cursor area, display the maximum value, minimum value, root mean square, etc.
- Customizable trigger conditions
- Status monitoring capabilities of the drive and its digital I/O.

● Device Tree Layout

Luna software leverages the device tree layout, multi-window access functionality and clear function classification for improved user experience.

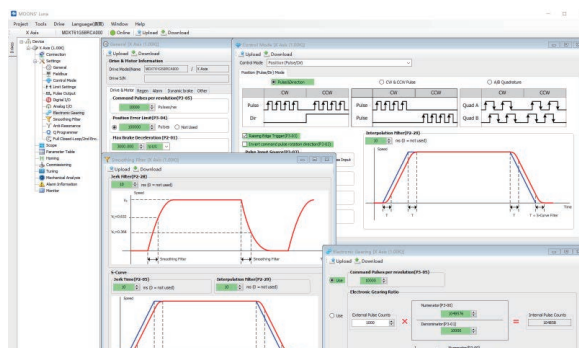

● Mechanical Analysis

Quickly diagnose the frequency characteristics of mechanical equipment via the Mechanical Analysis tools. Results can be used to set various notch filters to minimize the effects of resonance.

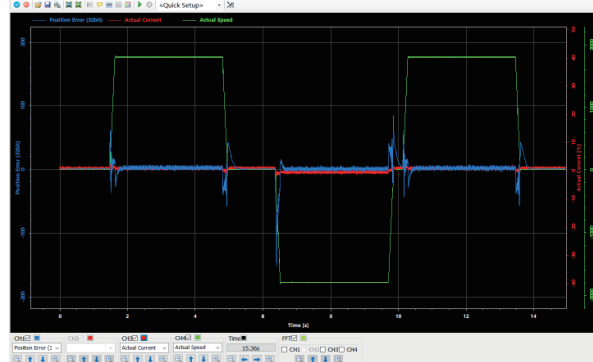
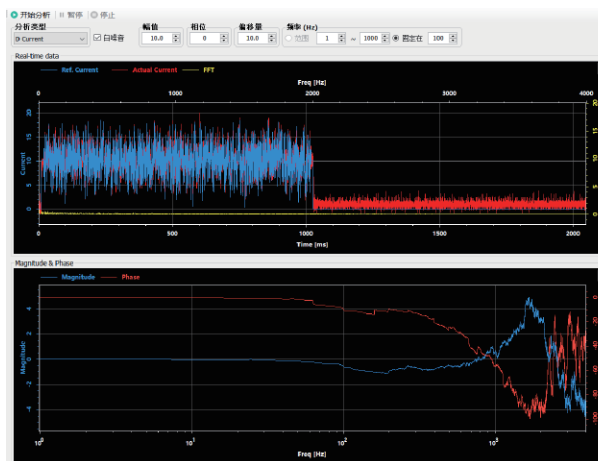

■ General Specifications

● Safety Certification

MDX+ series products are designed to meet the following standards.



		Drive	Motor
Europe	EMC	EN 61800-3	EN 60034-1
			EN 61000-6-2
			EN 61000-6-4
	LVD	EN 61800-5-1	EN 60034-1 EN 60034-5
Function Safety (STO)		UL61800-5-2(SIL 3)	
		IEC61508	
		ISO13849-1(PL e)	
UL Standard		UL 61800-5-1	UL 1004-1 UL 1004-6
CSA Standard		C22.2 No.274-13	CSA C22.2 No.100

● Brake Specifications

Electromagnetic brakes, like those available on MDX+, are used to prevent undesired motion when the servo system is shut down. The most common use case for brakes are vertical applications in which they are used to prevent the load from falling in the event of power loss.

When the brake is powered on, its armature is retracted and the brake pad is released, allowing for rotation of the motor shaft. When the brake is powered off, the armature is released, the brake pad is re-applied and normal operation of the motor is no longer possible.

Frame	40mm	60mm	80mm
Static Friction Torque (Nm)	0.32	1.5	3.2
Rated Voltage (VDC)	24		
Power Waste (W @ 20°C)	6.3	7.2	9.6
Current (A)	0.26	0.3	0.4
Braking Time	< 70ms (Standard air gap, at 20°C)		
Release Time	< 25ms		
Release Voltage	18.5VDC max. (at 20°C)		

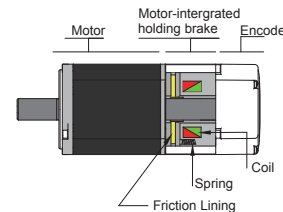

● Shaft Seal

Industrial oil seals can block contaminants (oils, impurities) to extend the life of the motor. The oil seal will produce a certain resistance to the motor shaft, Motor torque output should be de-rated by 10%.

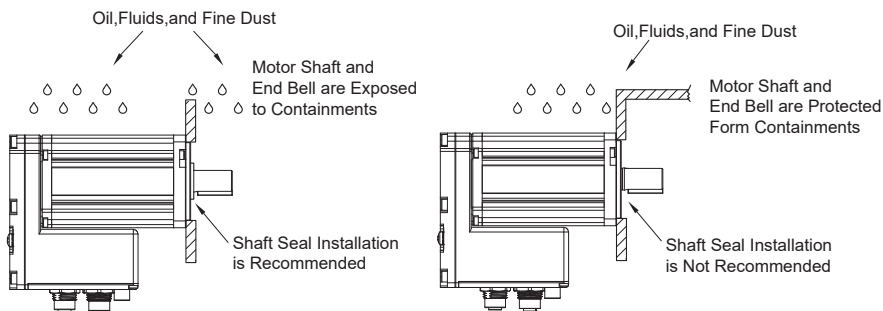



MDX+ Numbering System

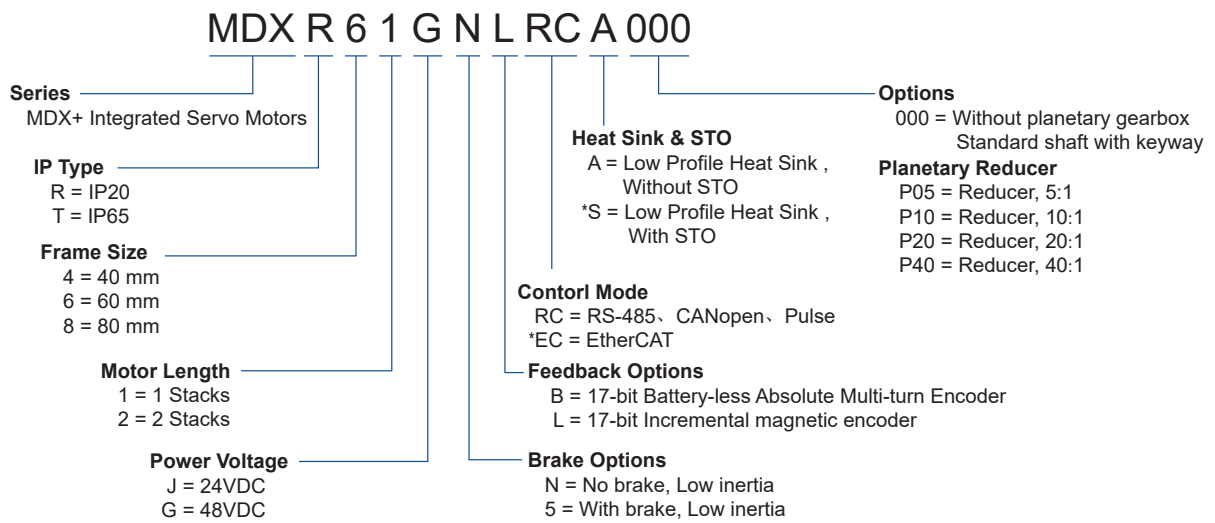

*S: With STO type is under development
*EC: Only for IP65 type support EtherCAT bus

MDX+ Product System

Rated Power W	Frame Size mm	Rated Speed (Max.Speed) rpm
100	40	3000 (5000)
200	60	3000 (6000)
400	60	3000 (3900)
550	80	3000 (3600)

Basic information

■ Frame Size 40mm Specification

Type		MDXR42J□◇○A000	MDXT42J□◇○A000
IP Rating		IP20	IP65
Power Rating(3000rpm)		100W	100W
Main Power Supply	Input Voltage	24V ~ 60VDC	
	Recommend Input Voltage	24VDC	
Auxiliary Power	Input Voltage	24VDC±10%	
Withstand Voltage		Primary to earth: withstand 500 VDC, 1 min	
Environment	Temperature	<ul style="list-style-type: none"> ◆ Ambient temperature: 0°C ~ 50°C (If the ambient temperature of servo drive is higher than 45°C, please install the drive in a well-ventilated location) ◆ Storage temperature: -20°C ~ 65°C 	
	Humidity	Both operating and storage : 10 ~ 85%RH or less	
	Altitude	Lower than 1000m	
	Vibration	9.8m/s ² or less, 10 ~ 60Hz (Do not use continuously at resonance frequency)	
Encoder		<ul style="list-style-type: none"> ◆ 17-bit Battery-less absolute encoder ◆ 17-bit Incremental magnetic encoder 	
I/O	Digital Signal	Input	<ul style="list-style-type: none"> ◆ 4 Configurable optically isolate digital general inputs, 24VDC, 20mA ◆ 2 Configurable optically isolate digital general inputs, 24VDC, 20mA
		Output	<ul style="list-style-type: none"> ◆ 3 Configurable optically isolate digital general outputs, Max.30VDC, 30mA ◆ 2 Configurable optically isolate digital general outputs, Max.30VDC, 30mA
	Analog Signal	Input	1 Analog input, (-10 ~ +10V, 12-bit)
	Pulse Signal	Input	5V, minimum pulse width 250ns, max. pulse frequency 2MHz; 24V, minimum pulse width 1μs, max. pulse frequency 500KHz
Output		Line driver: 3 outputs ◆ Encoder A±, B±, Z± feedback output	No
Comm Port	USB Mini	Connection with PC for configuration	
	EtherCAT	No	EtherCAT
	CANopen	CANopen	
	RS-485	Modbus/RTU	
LED Display		Red and green status indicator	
Control Mode		<ul style="list-style-type: none"> ◆ EtherCAT Communication control mode: CoE(compliant with CiA402 standard) supports PP, PV, TQ, CSP, CSV, CST and HM modes ◆ CANopen Communication control mode: Comply with CiA402 standard, support PP, PV, PVT, TQ and HM modes ◆ Modbus/RTU Communication control mode: Instruction position mode, instruction speed mode, instruction torque mode 	
Control Input Signal		Alarm Reset, CW/CCW Limit, Gain Select, Emergency Stop, Zero Speed Clamp, Torque Limit, Speed Limit, General Purpose Input	
Control Output Signal		Warning Output, Fault Output, Servo Ready, Velocity Reached, Torque Reached, Position Reached, Servo-on Status, Dynamic Position Error Following, Positioning Complete, Zero Speed Detected, Velocity Coincidence, Torque Coincidence, Velocity limit, Torque limit, Homing Finished, Soft Limit CW/CCW, General Purpose Output	
Protection		Over Current, Over Voltage, Low Voltage, Over Heating, Encoder Fault, Over Load, Over Speed, Position Error, Emergency Stop, CW/CCW Limit, Communication Error	
Dynamic Brake		Built in	
STO*1		Built in	
Certification		RoHS、CE	

□: Brake Options , please refer to page 10 MDX+ Numbering System

◇: Encoder Options , please refer to page 10 MDX+ Numbering System

○: Control&Communication Options, please refer to page 10 MDX+ Numbering System

*1: Certain models don't support this function, please refer to page10 MDX+ Numbering System

■ Frame Size 60mm Specification

Type		MDXR61G□◇○A000	MDXR62G□◇○A000	MDXT61G□◇○A000	MDXT62G□◇○A000
IP Rating		IP20		IP65	
Power Rating(3000rpm)		200W	400W	200W	400W
Main Power Supply	Input Voltage	24V ~ 60VDC			
	Recommend Input Voltage	48VDC			
Auxiliary Power	Input Voltage	24VDC±10%			
Withstand Voltage		Primary to earth: withstand 500 VDC, 1 min			
Environment	Temperature	<ul style="list-style-type: none"> ◆ Ambient temperature: 0°C ~ 50°C (If the ambient temperature of servo drive is higher than 45°C, please install the drive in a well-ventilated location) ◆ Storage temperature: -20°C ~ 65°C 			
	Humidity	Both operating and storage : 10 ~ 85%RH or less			
	Altitude	Lower than 1000m			
	Vibration	9.8m/s ² or less, 10 ~ 60Hz (Do not use continuously at resonance frequency)			
Encoder		<ul style="list-style-type: none"> ◆ 17-bit Battery-less absolute encoder ◆ 17-bit Incremental magnetic encoder 			
I/O	Digital Signal	Input	◆ 4 Configurable optically isolate digital general inputs, 24VDC, 20mA	◆ 2 Configurable optically isolate digital general inputs, 24VDC, 20mA	
		Output	◆ 3 Configurable optically isolate digital general outputs, Max.30VDC, 30mA	◆ 2 Configurable optically isolate digital general outputs, Max.30VDC, 30mA	
	Analog Signal	Input	1 Analog input, (-10 ~ +10V, 12-bit)		
	Pulse Signal	Input	5V, minimum pulse width 250ns, max. pulse frequency 2MHz; 24V, minimum pulse width 1μs, max. pulse frequency 500KHz	24V, minimum pulse width 1μs, max. pulse frequency 500KHz	
Output		Line driver: 3 outputs ◆ Encoder A±, B±, Z± feedback output	No		
Comm Port	USB Mini		Connection with PC for configuration		
	EtherCAT		No	EtherCAT	
	CANopen		CANopen		
	RS-485		Modbus/RTU		
LED Display		Red and green status indicator			
Control Mode		<ul style="list-style-type: none"> ◆ EtherCAT Communication control mode: CoE(compliant with CiA402 standard) supports PP, PV, TQ, CSP, CSV, CST and HM modes ◆ CANopen Communication control mode: Comply with CiA402 standard, support PP, PV, PVT, TQ and HM modes ◆ Modbus/RTU Communication control mode: Instruction position mode, instruction speed mode, instruction torque mode 			
Control Input Signal		Alarm Reset, CW/CCW Limit, Gain Select, Emergency Stop, Zero Speed Clamp, Torque Limit, Speed Limit, General Purpose Input			
Control Output Signal		Warning Output, Fault Output, Servo Ready, Velocity Reached, Torque Reached, Positon Reached, Servo-on Status, Dynamic Position Error Following, Positioning Complete, Zero Speed Detected, Velocity Coincidence, Torque Coincidence, Velocity limit, Torque limit, Homing Finished, Soft Limit CW/CCW, General Purpose Output			
Protection		Over Current, Over Voltage, Low Voltage, Over Heating, Encoder Fault, Over Load,Over Speed, Position Error, Emergency Stop,CW/CCW Limit, Communication Error			
Dynamic Brake		Built in			
STO*1		Built in			
Certification		RoHS、CE			

□: Brake Options , please refer to page 10 MDX+ Numbering System

◇: Encoder Options , please refer to page 10 MDX+ Numbering System

○: Control&Communication Options, please refer to page 10 MDX+ Numbering System

*1: Certain models don't support this function, please refer to page10 MDX+ Numbering System

Features

Numbering System

Basic Information

System Configuration

Accessories

Ordering Information

■ Frame Size 80mm Specification

Type		MDXR82G□◇○A000	MDXT82G□◇○A000	
IP Rating		IP20	IP65	
Power Rating(3000rpm)		550W	550W	
Main Power Supply	Input Voltage	24V ~ 60VDC		
	Recommend Input Voltage	48VDC		
Auxiliary Power	Input Voltage	24VDC ± 10%		
Withstand Voltage		Primary to earth: withstand 500 VDC, 1 min		
Environment	Temperature	<ul style="list-style-type: none"> ◆ Ambient temperature: 0°C ~ 50°C (If the ambient temperature of servo drive is higher than 45°C, please install the drive in a well-ventilated location) ◆ Storage temperature: -20°C ~ 65°C 		
	Humidity	Both operating and storage : 10 ~ 85%RH or less		
	Altitude	Lower than 1000m		
	Vibration	9.8m/s ² or less, 10 ~ 60Hz (Do not use continuously at resonance frequency)		
Encoder		<ul style="list-style-type: none"> ◆ 17-bit Battery-less absolute encoder ◆ 17-bit Incremental magnetic encoder 		
I/O	Digital Signal	Input	<ul style="list-style-type: none"> ◆ 4 Configurable optically isolate digital general inputs, 24VDC, 20mA 	<ul style="list-style-type: none"> ◆ 2 Configurable optically isolate digital general inputs, 24VDC, 20mA
		Output	<ul style="list-style-type: none"> ◆ 3 Configurable optically isolate digital general outputs, Max.30VDC, 30mA 	<ul style="list-style-type: none"> ◆ 2 Configurable optically isolate digital general outputs, Max.30VDC, 30mA
	Analog Signal	Input	1 Analog input, (-10 ~ +10V, 12-bit)	
	Pulse Signal	Input	5V, minimum pulse width 250ns, max. pulse frequency 2MHz; 24V, minimum pulse width 1μs, max. pulse frequency 500KHz	24V, minimum pulse width 1μs, max. pulse frequency 500KHz
Output		Line driver: 3 outputs ◆ Encoder A±, B±, Z± feedback output	No	
Comm Port	USB Mini		Connection with PC for configuration	
	EtherCAT		No	EtherCAT
	CANopen		CANopen	
	RS-485		Modbus/RTU	
LED Display		Red and green status indicator		
Control Mode		<ul style="list-style-type: none"> ◆ EtherCAT Communication control mode: CoE(compliant with CiA402 standard) supports PP, PV, TQ, CSP, CSV, CST and HM modes ◆ CANopen Communication control mode: Comply with CiA402 standard, support PP, PV, PVT, TQ and HM modes ◆ Modbus/RTU Communication control mode: Instruction position mode, instruction speed mode, instruction torque mode 		
Control Input Signal		Alarm Reset, CW/CCW Limit, Gain Select, Emergency Stop, Zero Speed Clamp, Torque Limit, Speed Limit, General Purpose Input		
Control Output Signal		Warning Output, Fault Output, Servo Ready, Velocity Reached, Torque Reached, Position Reached, Servo-on Status, Dynamic Position Error Following, Positioning Complete, Zero Speed Detected, Velocity Coincidence, Torque Coincidence, Velocity limit, Torque limit, Homing Finished, Soft Limit CW/CCW, General Purpose Output		
Protection		Over Current, Over Voltage, Low Voltage, Over Heating, Encoder Fault, Over Load, Over Speed, Position Error, Emergency Stop, CW/CCW Limit, Communication Error		
Dynamic Brake		Built in		
STO*1		Built in		
Certification		RoHS、CE		

□: Brake Options , please refer to page 10 MDX+ Numbering System

◇: Encoder Options , please refer to page 10 MDX+ Numbering System

○: Control&Communication Options, please refer to page 10 MDX+ Numbering System

*1: Certain models don't support this function, please refer to page 10 MDX+ Numbering System

■ Frame Size 40mm—Compact IP20 Type -RC--RS-485, CANopen, Pulse

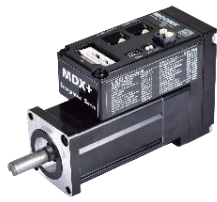

- IP20 Rating
- Frame Size: 40mm
- Power Rating: 100W
- 6 Digital Inputs
- 3 Digital Outputs
- 1 Analog Inputs
- Standard Shaft with Keyway
- Without Gearbox

Type		MDXR42J□◇RCA000	
Winding Type	VDC		24
Nominal Supply Voltage	VDC		24
Rated Speed	rpm		3000
Power Rating (at 3000rpm)	W		100
Continuous Torque	N·m		0.32
Peak Torque	N·m		0.96
Rotor Inertia	kg.m ²		0.0428 x 10 ⁻⁴
Rotor Inertia-with Brake	kg.m ²		0.0457 x 10 ⁻⁴
Shaft Load - Axial	N(max.)		50
Shaft Load - Radial (End of Shaft)	N(max.)		60
Weight	kg		MDXR42JN◇RCA000: 0.7
			MDXR42J5LRCA000: 1.1
			MDXR42J5BRCA000: 1.3

□ : Brake Options; ◇ : Encoder Options

□ Dimensions (Unit: mm)

1) Without Brake

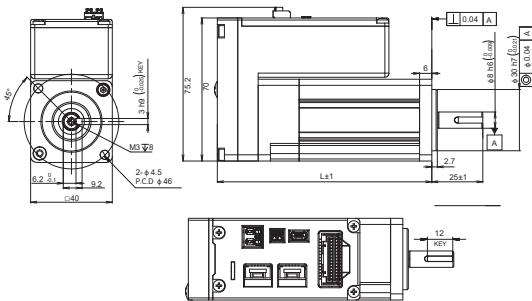

2) With Brake

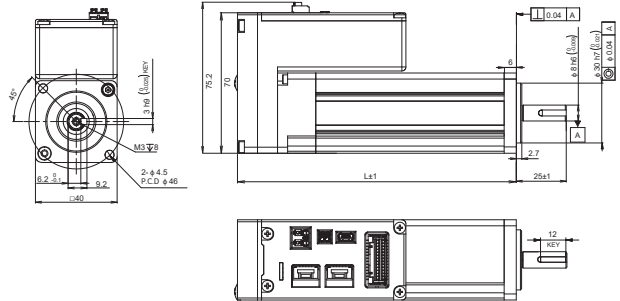

Without Brake	L
MDXR42JNLRCA000	105
MDXR42JNBRCA000	115

With Brake	L
MDXR42J5LRCA000	140
MDXR42J5BRCA000	150

□ Torque Curves

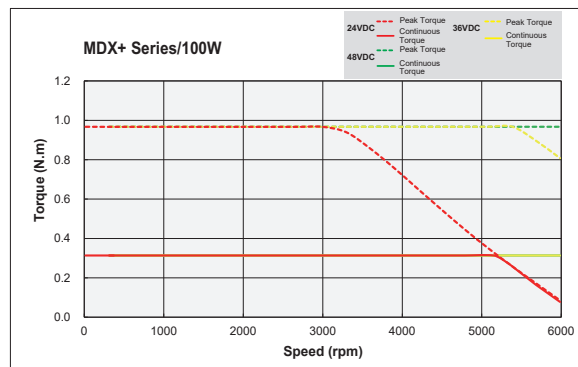
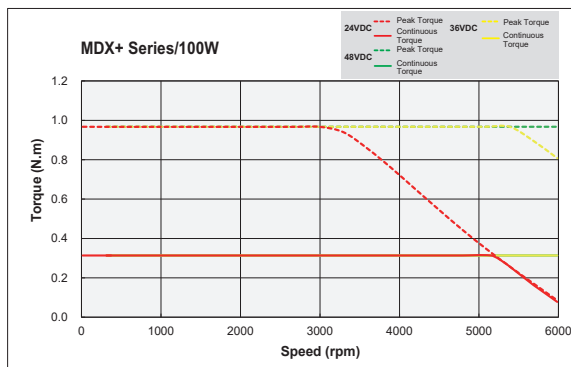

Features

Numbering System

Basic Information

System Configuration

Accessories

Ordering Information

■ Frame Size 40mm—Compact IP65 Type -RC--RS-485, CANopen, Pulse



- IP65 Rating
- Frame Size: 40mm
- Power Rating: 100W
- 4 Digital Inputs
- 2 Digital Outputs
- 1 Analog Inputs
- Standard Shaft with Keyway
- Without Gearbox

Type		MDXT42J□◇RCA000
Winding Type	VDC	24
Nominal Supply Voltage	VDC	24
Rated Speed	rpm	3000
Power Rating (at 3000rpm)	W	100
Continuous Torque	N·m	0.32
Peak Torque	N·m	0.96
Rotor Inertia	kg.m ²	0.0428 x 10 ⁻⁴
Rotor Inertia-with Brake	kg.m ²	0.0457 x 10 ⁻⁴
Shaft Load - Axial	N(max.)	50
Shaft Load - Radial (End of Shaft)	N(max.)	60
Weight	kg	MDXT42JN◇RCA000: 0.7
		MDXT42JLBRCA000: 1.1
		MDXT42J5BRCA000: 1.3

□ : Brake Options; ◇ : Encoder Options

□ Dimensions (Unit: mm)

1) Without Brake

2) With Brake

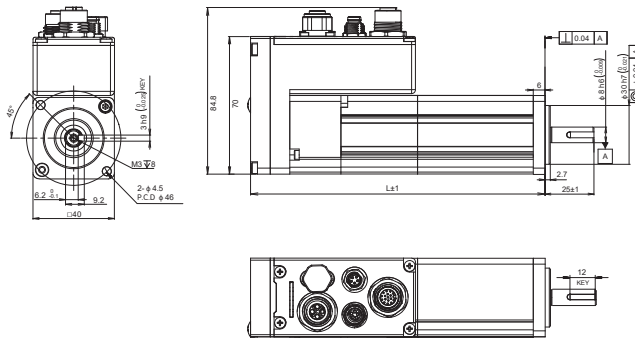
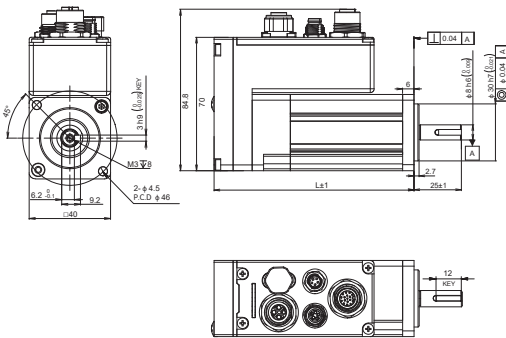

Without Brake	L
MDXT42JNLRCA000	105
MDXT42JNBRCA000	115

With Brake	L
MDXT42J5LRCA000	140
MDXT42J5BRCA000	150

□ Torque Curves

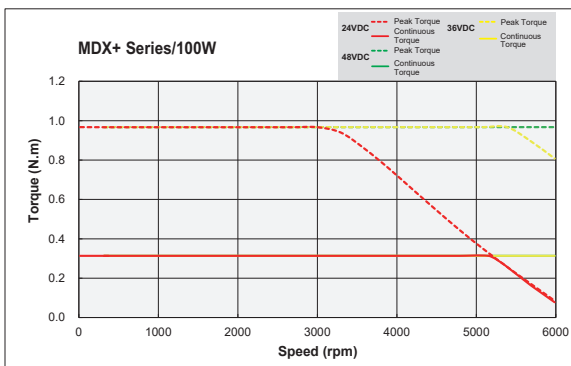

■ Frame Size 40mm—Compact IP65 Type -EC--EtherCAT



- IP65 Rating
- Frame Size: 40mm
- Power Rating: 100W
- 4 Digital Inputs
- 2 Digital Outputs
- 1 Analog Inputs
- Standard Shaft with Keyway
- Without Gearbox

Type		MDXT42J□◇ECA000
Winding Type	VDC	24
Nominal Supply Voltage	VDC	24
Rated Speed	rpm	3000
Power Rating (at 3000rpm)	W	100
Continuous Torque	N·m	0.32
Peak Torque	N·m	0.96
Rotor Inertia	kg.m ²	0.0428 x 10 ⁻⁴
Rotor Inertia-with Brake	kg.m ²	0.0457 x 10 ⁻⁴
Shaft Load - Axial	N(max.)	50
Shaft Load - Radial (End of Shaft)	N(max.)	60
Weight	kg	MDXT42JN◇ECA000: 0.7
		MDXT42JLBECA000: 1.1
		MDXT42J5BECA000: 1.3

□ : Brake Options; ◇ : Encoder Options

□ Dimensions (Unit: mm)

1) Without Brake

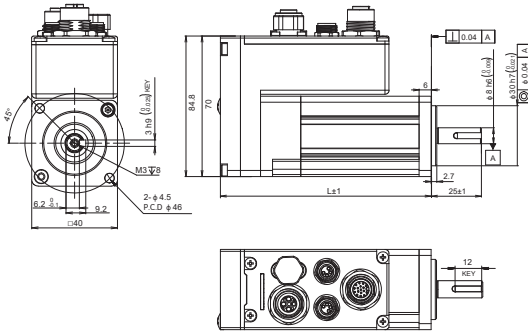

2) With Brake

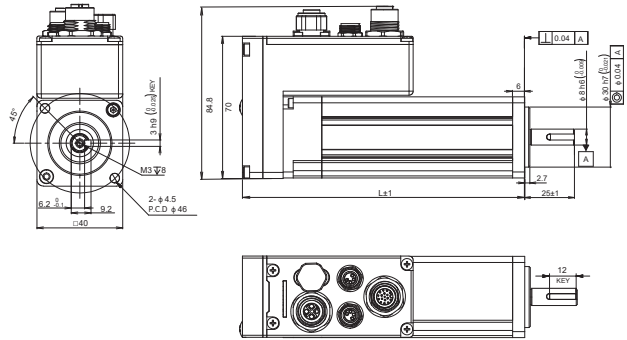

Without Brake	L
MDXT42JNLECA000	105
MDXT42JNBECA000	115

With Brake	L
MDXT42J5LECA000	140
MDXT42J5BECA000	150

□ Torque Curves

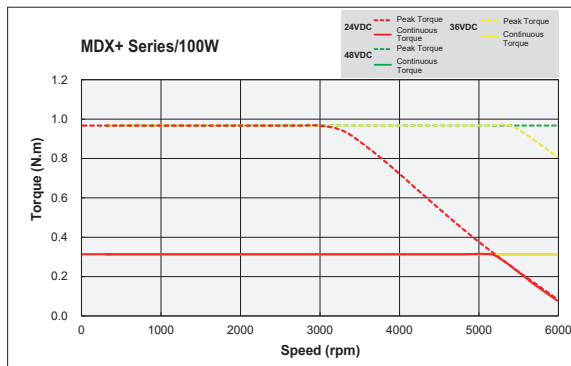

Features

Numbering System

Basic Information

System Configuration

Accessories

Ordering Information

■ Frame Size 60mm—Compact IP20 Type -RC--RS-485, CANopen, Pulse

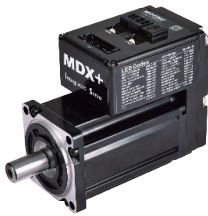

- IP20 Rating
- Frame Size: 60mm
- Power Rating: 200W, 400W
- 6 Digital Inputs
- 3 Digital Outputs
- 1 Analog Inputs
- Standard Shaft with Keyway
- Without Gearbox

Type		MDXR61G□◇RCA000		MDXR62G□◇RCA000	
Winding Type	VDC	48		48	
Nominal Supply Voltage	VDC	24	48	24	48
Rated Speed	rpm	2000	3000	1600	3000
Power Rating (at 3000rpm)	W	200		400	
Continuous Torque	N·m	0.64		1.27	
Peak Torque	N·m	1.9		3.8	
Rotor Inertia	kg·m ²	0.156 x 10 ⁻⁴		0.3 x 10 ⁻⁴	
Rotor Inertia-with Brake	kg·m ²	0.162 x 10 ⁻⁴		0.327 x 10 ⁻⁴	
Shaft Load - Axial	N(max.)	70		70	
Shaft Load - Radial (End of Shaft)	N(max.)	200		240	
Weight	kg	MDXR61GNLRCA000: 1.2		MDXR62GNLRCA000: 1.6	
		MDXR61GNBRCA000: 1.4		MDXR62GNBRCA000: 1.9	
		MDXR61G5◇RCA000: 1.8		MDXR62G5◇RCA000: 2.3	

□ : Brake Options; ◇ : Encoder Options

□ Dimensions (Unit: mm)

1) Without Brake

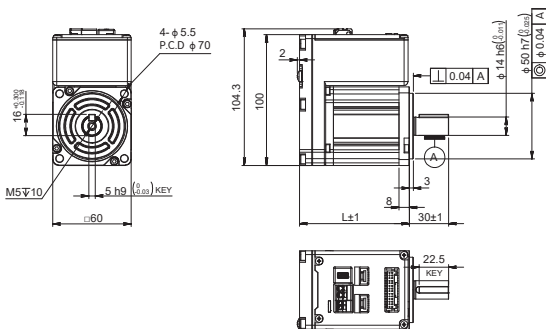

2) With Brake

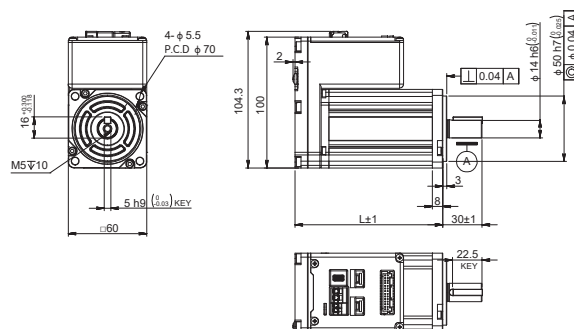

Without Brake	L
MDXR61GNLRCA000	84
MDXR61GNBRCA000	108.5
MDXR62GNLRCA000	113
MDXR62GNBRCA000	137.5

With Brake	L
MDXR61G5LRCA000	148
MDXR61G5BRCA000	148
MDXR62G5LRCA000	177
MDXR62G5BRCA000	177

□ Torque Curves

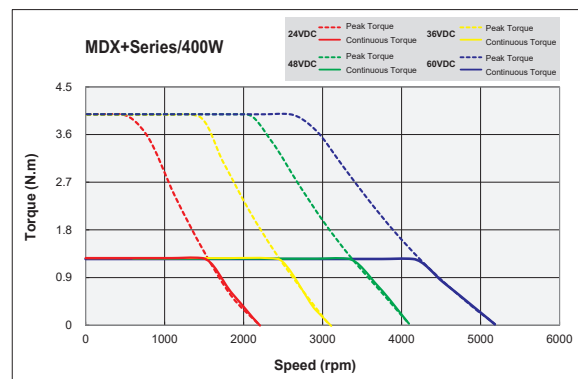
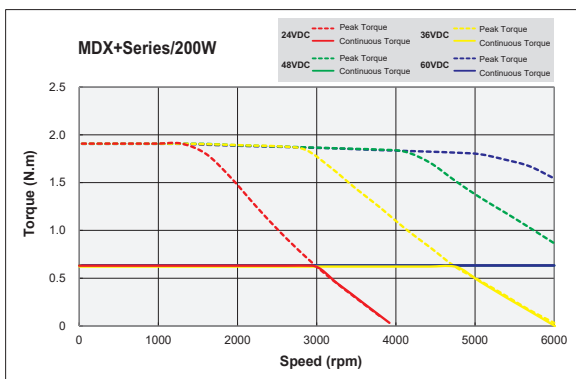

■ Frame Size 60mm—Compact IP65 Type -RC--RS-485, CANopen, Pulse



- IP65 Rating
- Frame Size: 60mm
- Power Rating: 200W, 400W
- 4 Digital Inputs
- 2 Digital Outputs
- 1 Analog Inputs
- Standard Shaft with Keyway
- Without Gearbox

Features

Numbering System

Basic Information

System Configuration

Accessories

Ordering Information

Type		MDXT61G□◇RCA000		MDXT62G□◇RCA000	
Winding Type	VDC	48VDC		48VDC	
Nominal Supply Voltage	VDC	24	48	24	48
Rated Speed	rpm	2000	3000	1600	3000
Power Rating (at 3000rpm)	W	200		400	
Continuous Torque	N·m	0.64		1.27	
Peak Torque	N·m	1.9		3.8	
Rotor Inertia	kg·m ²	0.156 x 10 ⁻⁴		0.3 x 10 ⁻⁴	
Rotor Inertia-with Brake	kg·m ²	0.162 x 10 ⁻⁴		0.327 x 10 ⁻⁴	
Shaft Load - Axial	N(max.)	70		70	
Shaft Load - Radial (End of Shaft)	N(max.)	200		240	
Weight	kg	MDXT61GNLRCA000: 1.2		MDXT62GNLRCA000: 1.7	
		MDXT61GNBRCA000: 1.4		MDXT62GNBRCA000: 1.9	
		MDXT61G5◇RCA000: 1.8		MDXT62G5◇RCA000: 2.3	

□ : Brake Options; ◇ : Encoder Options

□ Dimensions (Unit: mm)

1) Without Brake

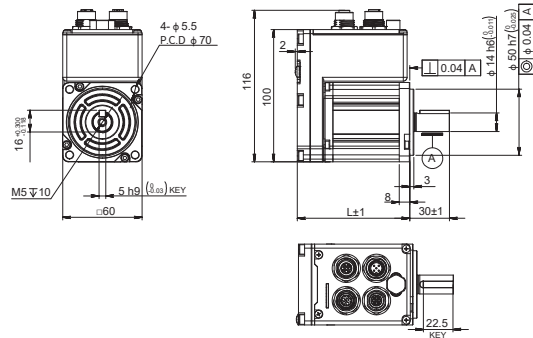

2) With Brake

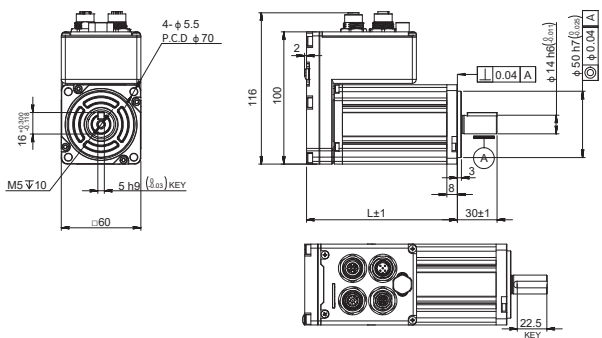

Without Brake	L
MDXT61GNLRCA000	85
MDXT61GNBRCA000	110.5
MDXT62GNLRCA000	114
MDXT62GNBRCA000	139.5

With Brake	L
MDXT61G5LRCA000	150
MDXT61G5BRCA000	150
MDXT62G5LRCA000	179
MDXT62G5BRCA000	179

□ Torque Curves

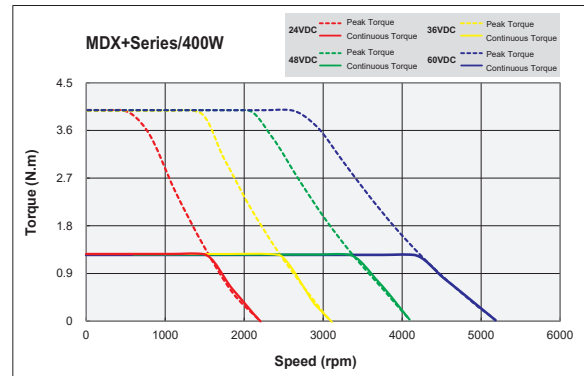
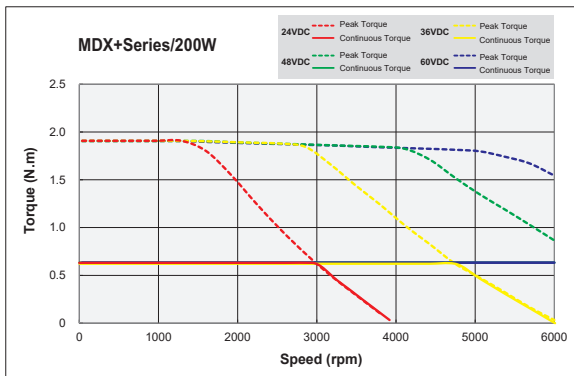

■ Frame Size 60mm—Compact IP65 Type -EC--EtherCAT

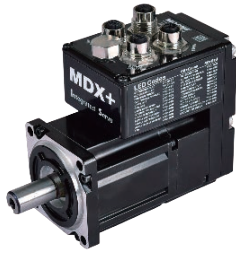

- IP65 Rating
- Frame Size: 60mm
- Power Rating: 200W, 400W
- 4 Digital Inputs
- 2 Digital Outputs
- 1 Analog Inputs
- Standard Shaft with Keyway
- Without Gearbox

Type		MDXT61G□◇ECA000		MDXT62G□◇ECA000	
Winding Type	VDC	48VDC		48VDC	
Nominal Supply Voltage	VDC	24	48	24	48
Rated Speed	rpm	2000	3000	1600	3000
Power Rating (at 3000rpm)	W	200		400	
Continuous Torque	N·m	0.64		1.27	
Peak Torque	N·m	1.9		3.8	
Rotor Inertia	kg·m ²	0.156 x 10 ⁻⁴		0.3 x 10 ⁻⁴	
Rotor Inertia-with Brake	kg·m ²	0.162 x 10 ⁻⁴		0.327 x 10 ⁻⁴	
Shaft Load - Axial	N(max.)	70		70	
Shaft Load - Radial (End of Shaft)	N(max.)	200		240	
Weight	kg	MDXT61GNLECA000: 1.2		MDXT62GNLECA000: 1.7	
		MDXT61GNBECA000: 1.4		MDXT62GNBECA000: 1.9	
		MDXT61G5◇ECA000: 1.8		MDXT62G5◇ECA000: 2.3	

□ : Brake Options; ◇ : Encoder Options

□ Dimensions (Unit: mm)

1) Without Brake

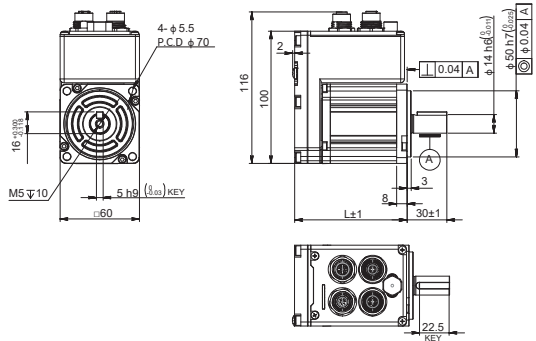

Without Brake	L
MDXT61GNLECA000	85
MDXT61GNBECA000	110.5
MDXT62GNLECA000	114
MDXT62GNBECA000	139.5

2) With Brake

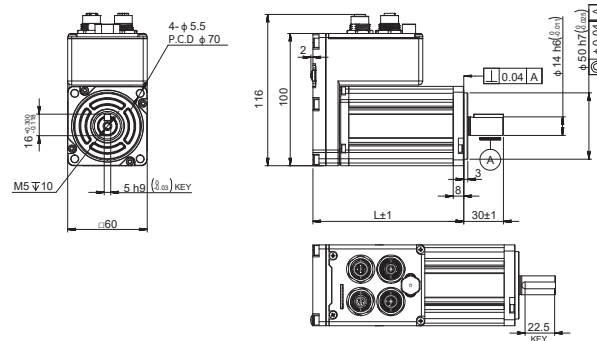

With Brake	L
MDXT61G5LECA000	150
MDXT61G5BECA000	150
MDXT62G5LECA000	179
MDXT62G5BECA000	179

□ Torque Curves

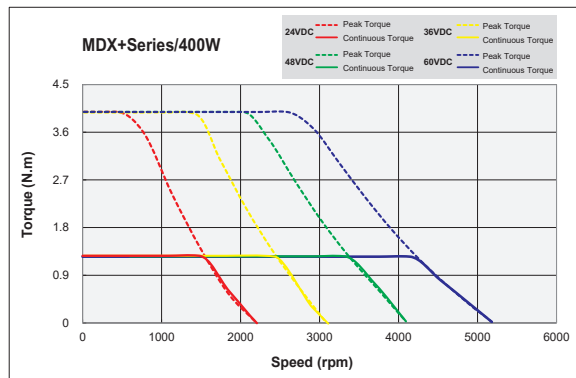
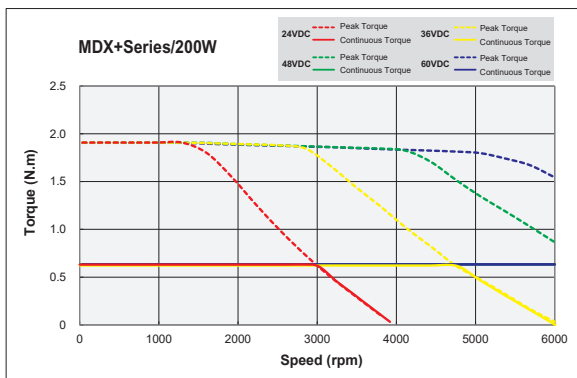

■ Frame Size 80mm—Compact IP20 Type -RC--RS-485, CANopen, Pulse



- IP20 Rating
- Frame Size: 80mm
- Power Rating: 550W
- 6 Digital Inputs
- 3 Digital Outputs
- 1 Analog Inputs
- Standard Shaft with Keyway
- Without Gearbox

Type		MDXR82G□◇RCA000
Winding Type	VDC	48
Nominal Supply Voltage	VDC	48
Rated Speed	rpm	3000
Power Rating (at 3000rpm)	W	550
Continuous Torque	N·m	1.8
Peak Torque	N·m	7.2
Rotor Inertia	kg.m ²	0.85 x 10 ⁻⁴
Rotor Inertia-with Brake	kg.m ²	0.927 x 10 ⁻⁴
Shaft Load - Axial	N(max.)	90
Shaft Load - Radial (End of Shaft)	N(max.)	270
Weight	kg	MDXR82GNLRC000: 2.6
		MDXR82GNBRCA000: 2.8
		MDXR82G5◇RCA000: 3.2

□ : Brake Options; ◇ : Encoder Options

□ Dimensions (Unit: mm)

1) Without Brake

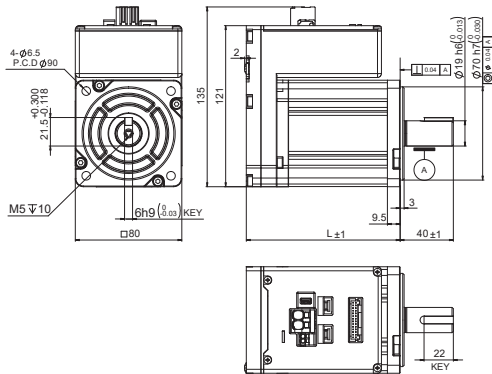

2) With Brake

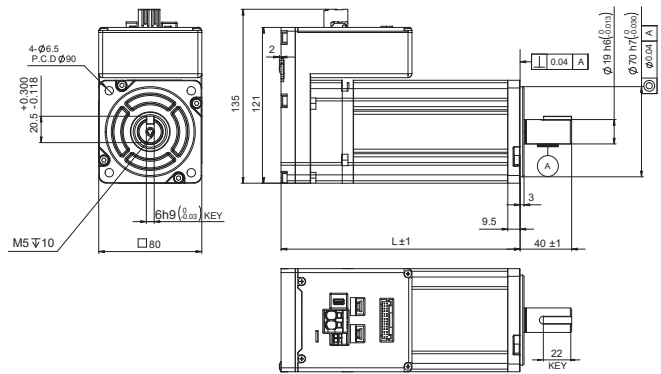

Without Brake	L1
MDXR82GNLRC000	115.5
MDXR82GNBRCA000	140

With Brake	L1
MDXR82G5LRCA000	185.5
MDXR82G5BRCA000	185.5

□ Torque Curves

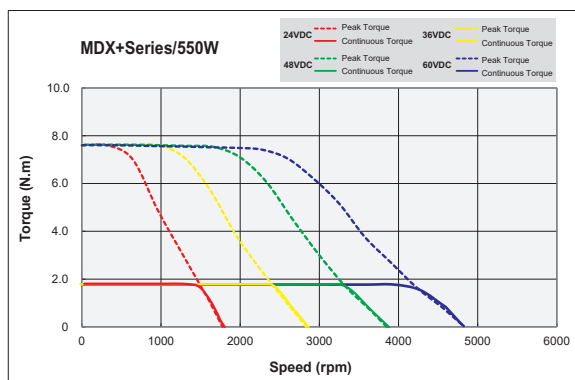

Features

Numbering System

Basic Information

System Configuration

Accessories

Ordering Information

■ Frame Size 80mm—Compact IP65 Type -RC--RS-485, CANopen, Pulse



- IP65 Rating
- Frame Size: 80mm
- Power Rating: 550W
- 4 Digital Inputs
- 2 Digital Outputs
- 1 Analog Inputs
- Standard Shaft with Keyway
- Without Gearbox

Type		MDXT82G□◇RCA000
Winding Type	VDC	48
Nominal Supply Voltage	VDC	48
Rated Speed	rpm	3000
Power Rating (at 3000rpm)	W	550
Continuous Torque	N·m	1.8
Peak Torque	N·m	7.2
Rotor Inertia	kg·m ²	0.85 x 10 ⁻⁴
Rotor Inertia-with Brake	kg·m ²	0.927 x 10 ⁻⁴
Shaft Load - Axial	N(max.)	90
Shaft Load - Radial (End of Shaft)	N(max.)	270
Weight	kg	MDXT82GNLRCA000: 2.6
		MDXT82GNBRCA000: 2.8
		MDXT82G5◇RCA000: 3.2

□ : Brake Options; ◇ : Encoder Options

□ Dimensions (Unit: mm)

1) Without Brake

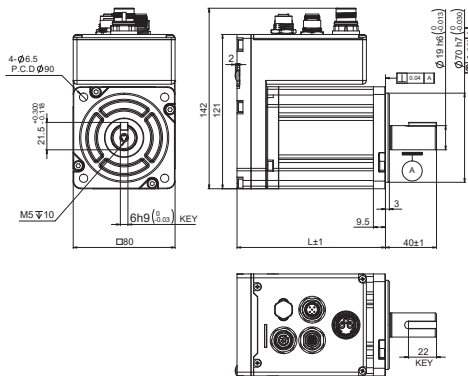

Without Brake	L
MDXT82GNLRCA000	116.5
MDXT82GNBRCA000	141

2) With Brake

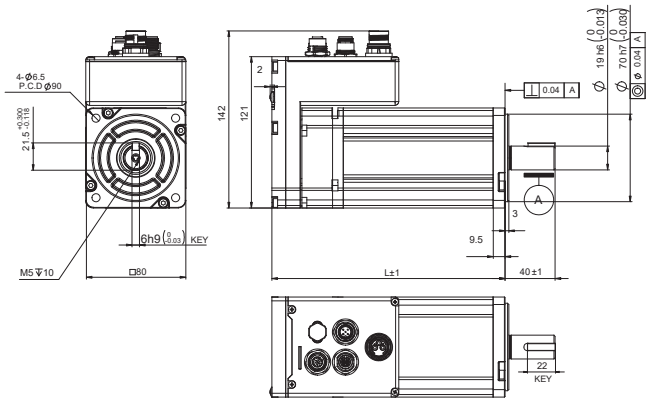

With Brake	L
MDXT82G5LRCA000	186.5
MDXT82G5BRCA000	186.5

□ Torque Curves

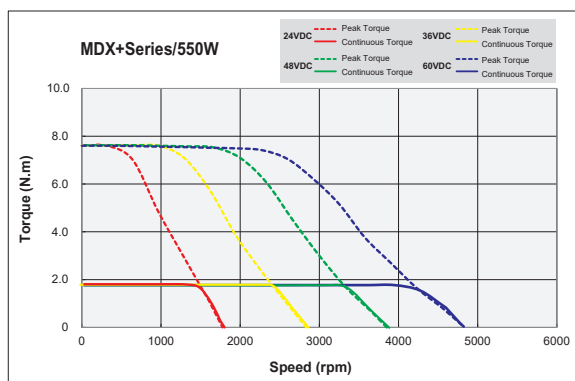

■ Frame Size 80mm—Compact IP65 Type -EC--EtherCAT



- IP65 Rating
- Frame Size: 80mm
- Power Rating: 550W
- 4 Digital Inputs
- 2 Digital Outputs
- 1 Analog Inputs
- Standard Shaft with Keyway
- Without Gearbox

Type		MDXT82G□◇ECA000
Winding Type	VDC	48
Nominal Supply Voltage	VDC	48
Rated Speed	rpm	3000
Power Rating (at 3000rpm)	W	550
Continuous Torque	N·m	1.8
Peak Torque	N·m	7.2
Rotor Inertia	kg.m ²	0.85 x 10 ⁻⁴
Rotor Inertia-with Brake	kg.m ²	0.927 x 10 ⁻⁴
Shaft Load - Axial	N(max.)	90
Shaft Load - Radial (End of Shaft)	N(max.)	270
Weight	kg	MDXT82GNLECA000: 2.6
		MDXT82GNBECA000: 2.8
		MDXT82G5◇ECA000: 3.2

□ : Brake Options; ◇ : Encoder Options

□ Dimensions (Unit: mm)

1) Without Brake

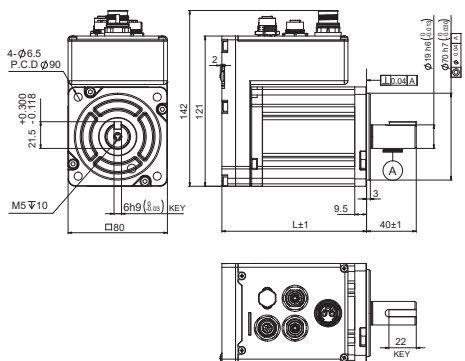

2) With Brake

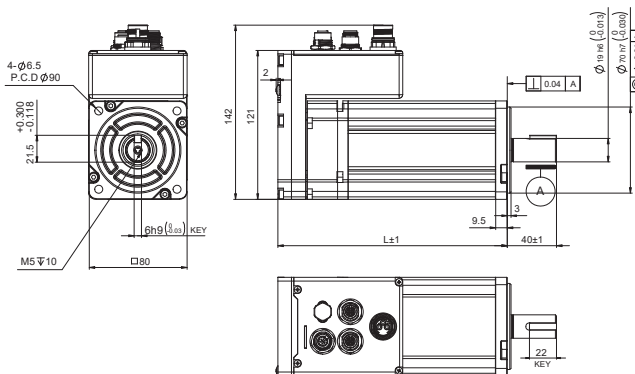

Without Brake	L
MDXT82GNLECA000	116.5
MDXT82GNBECA000	141

With Brake	L
MDXT82G5LECA000	186.5
MDXT82G5BECA000	186.5

□ Torque Curves

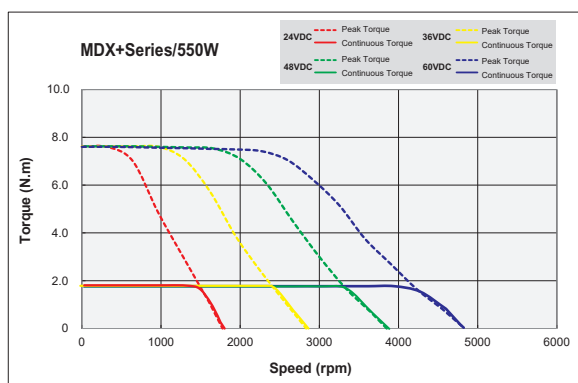

Features

Numbering System

Basic Information

System Configuration

Accessories

Ordering Information

IP20 System Configuration

■ Frame Size 40mm (100W)

● RC--RS-485, CANopen, Pulse

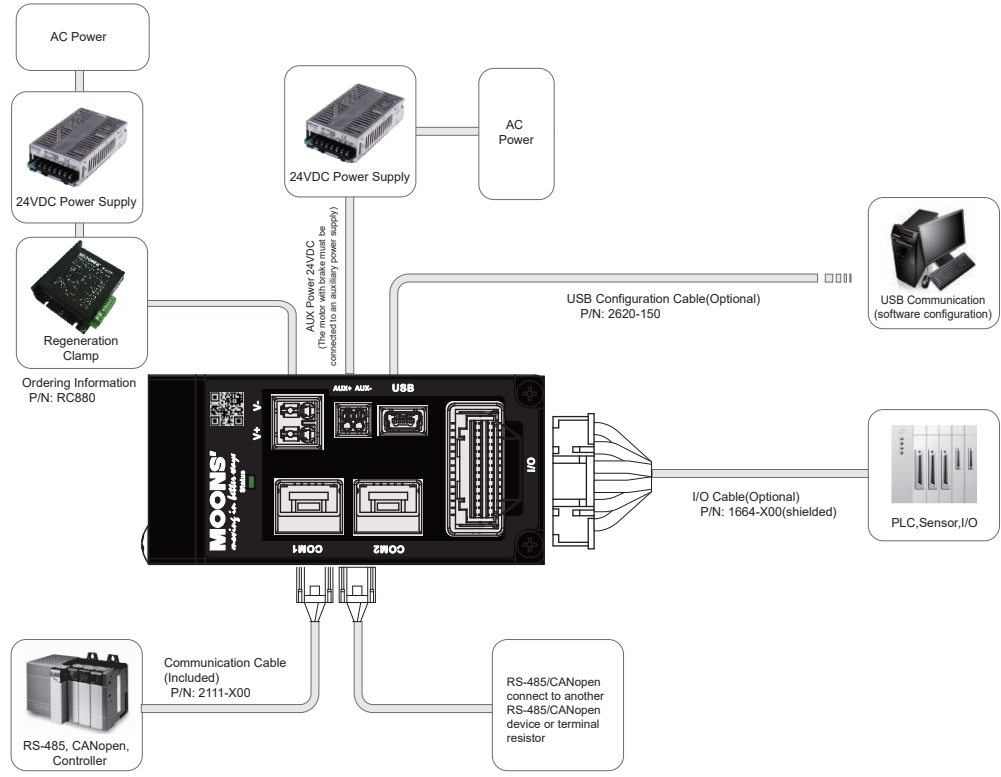

IP20 System Configuration

■ Frame Size 60mm (200W/400W)

● RC--RS-485, CANopen, Pulse

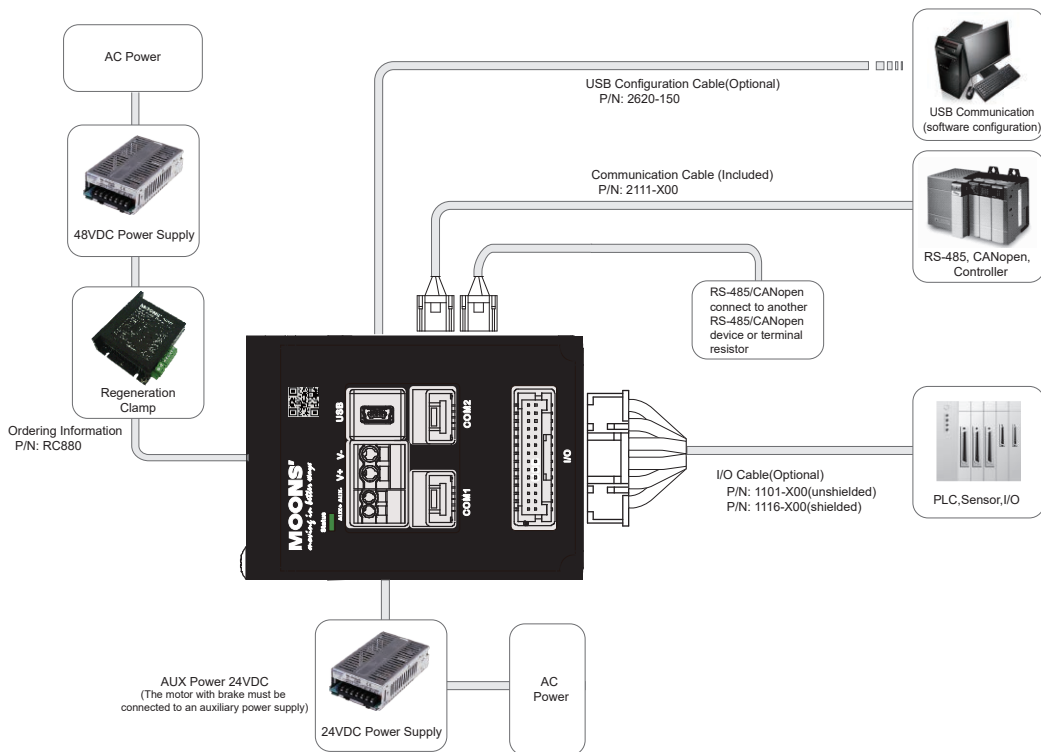

Features

Numbering System

Basic Information

System Configuration

Accessories

Ordering Information

IP20 System Configuration

■ Frame Size 80mm (550W)

● RC--RS-485, CANopen, Pulse

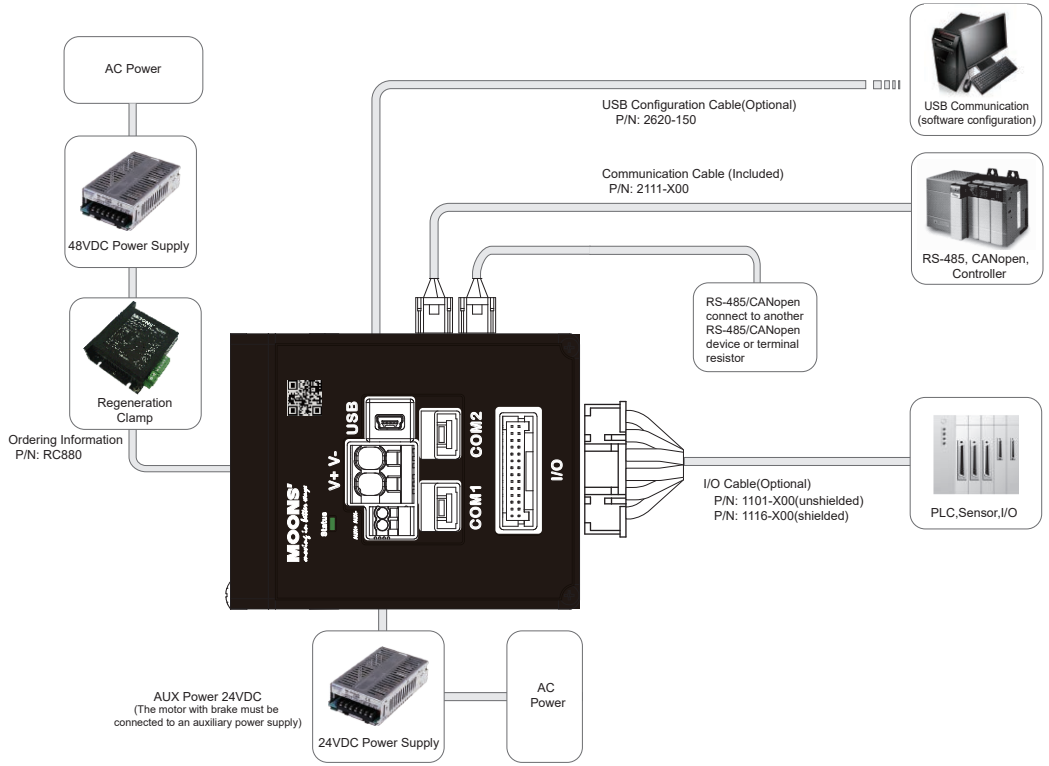

Features

Numbering System

Basic Information

System Configuration

Accessories

Ordering Information

IP65 System Configuration

■ Frame Size 40mm (100W)

● RC--RS-485, CANopen, Pulse

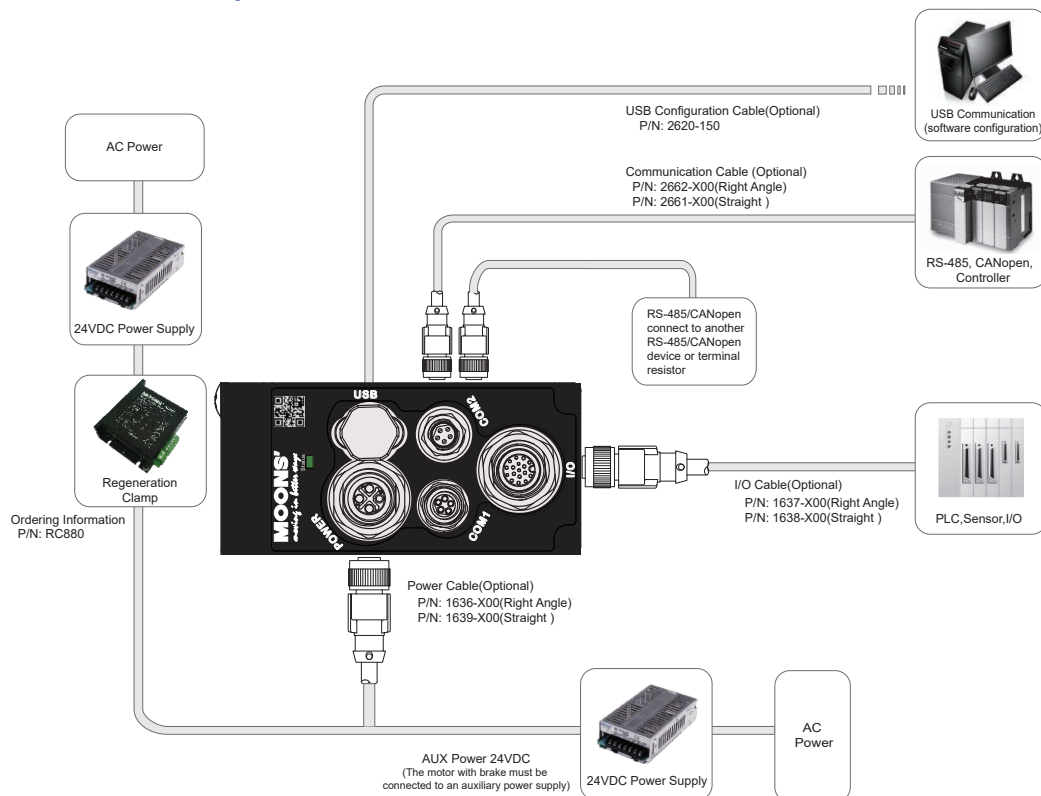

● EC--EtherCAT

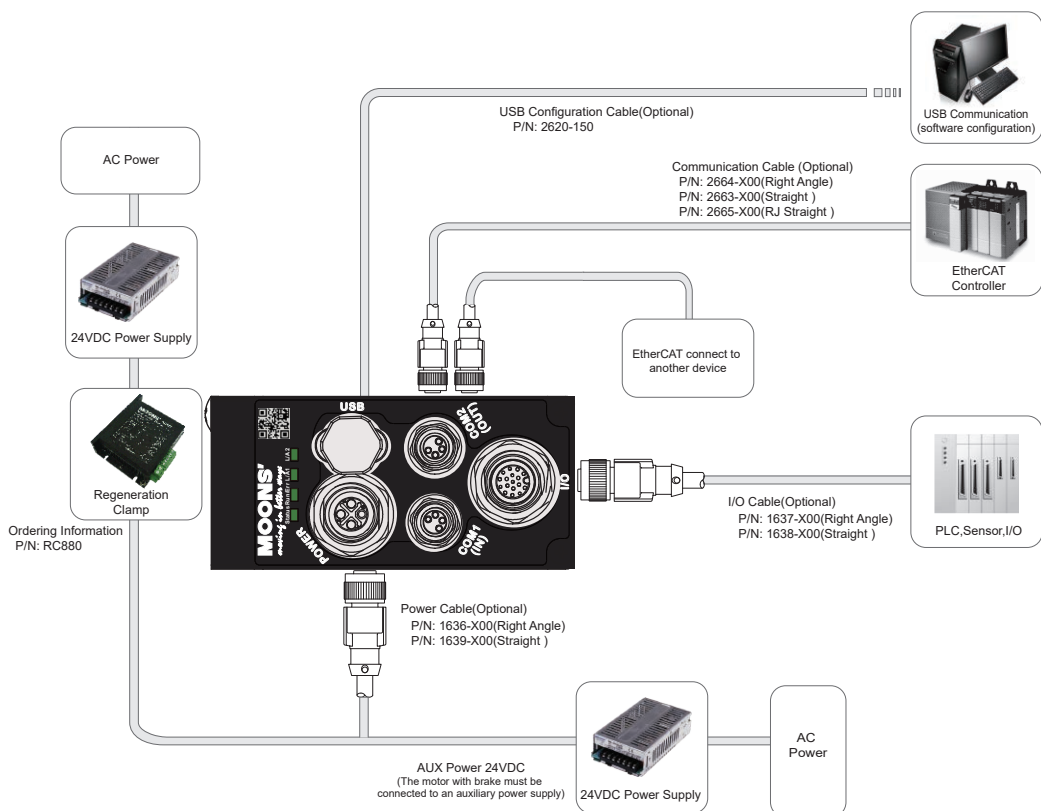

Features

Numbering System

Basic Information

System Configuration

Accessories

Ordering Information

IP65 System Configuration

■ Frame Size 60mm (200W/400W)

● RC--RS-485, CANopen, Pulse

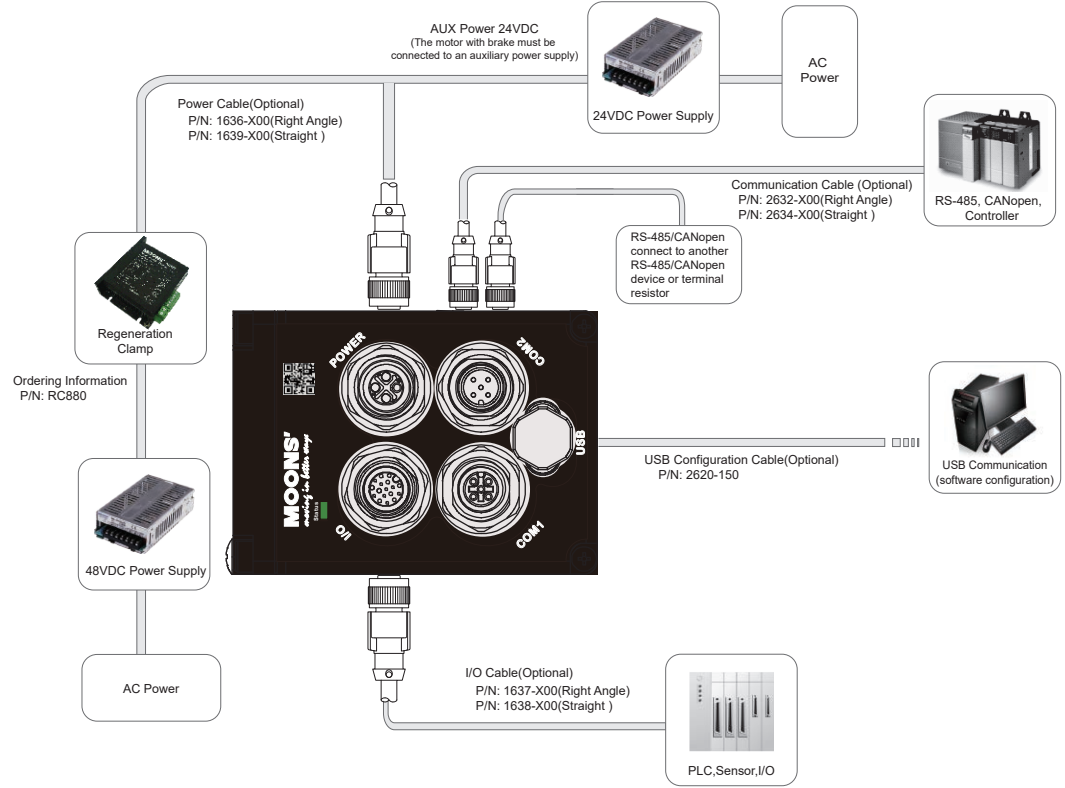

● EC--EtherCAT

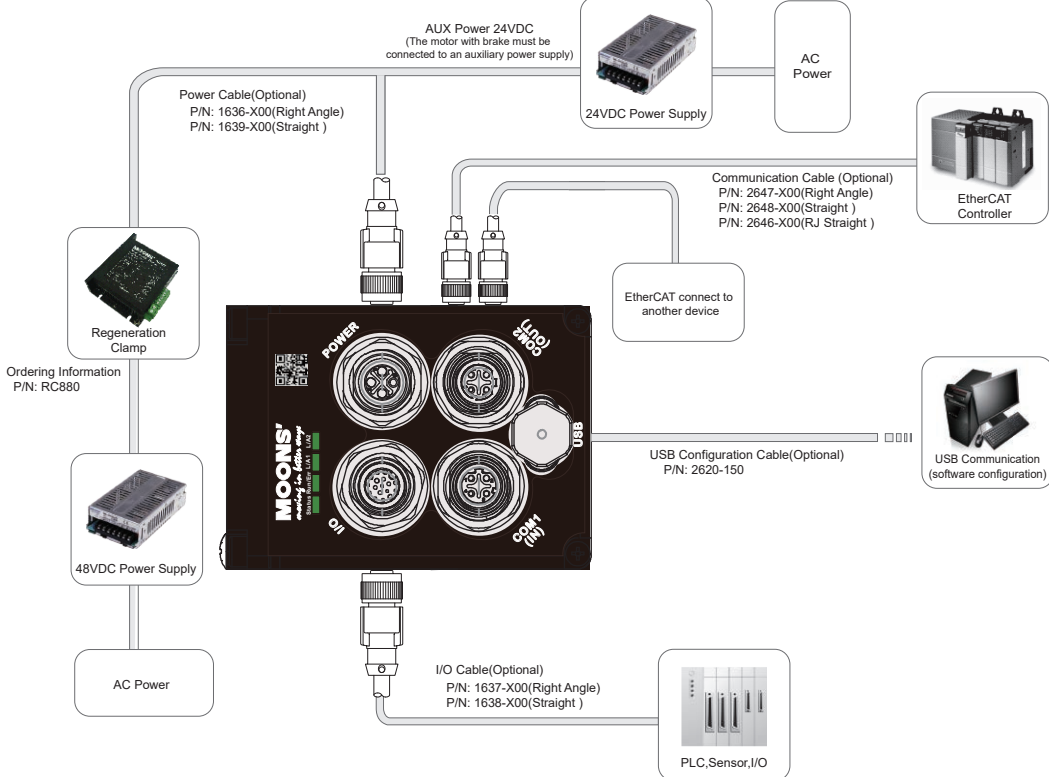

IP65 System Configuration

■ Frame Size 80mm (550W)

● RC--RS-485, CANopen, Pulse

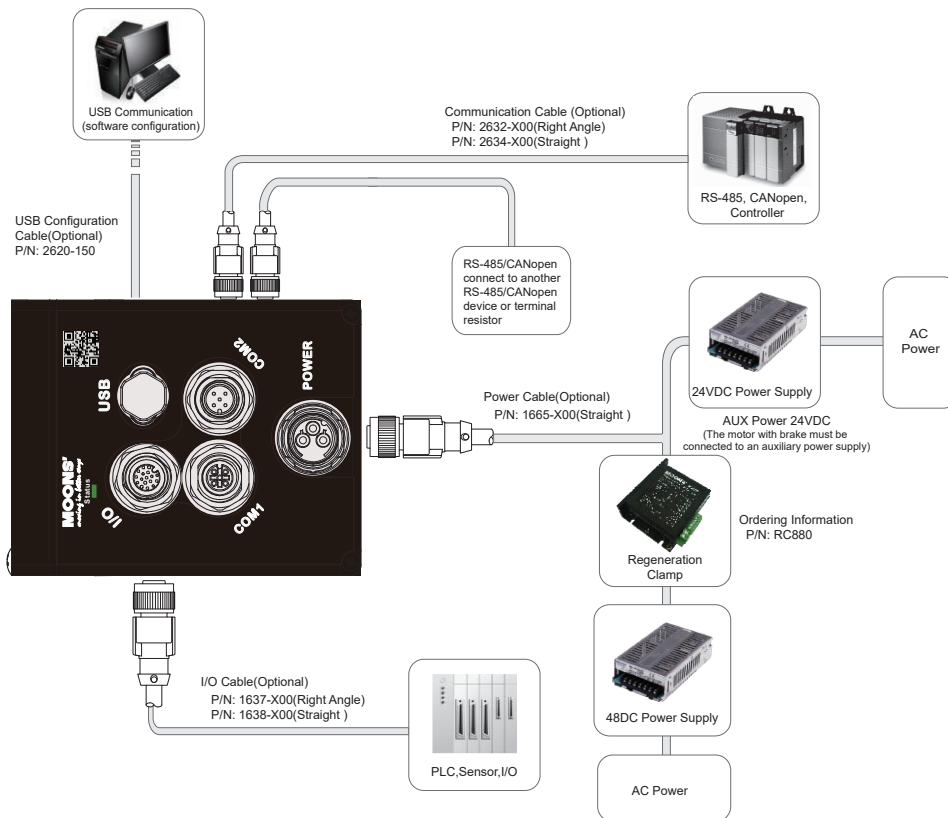

● EC--EtherCAT

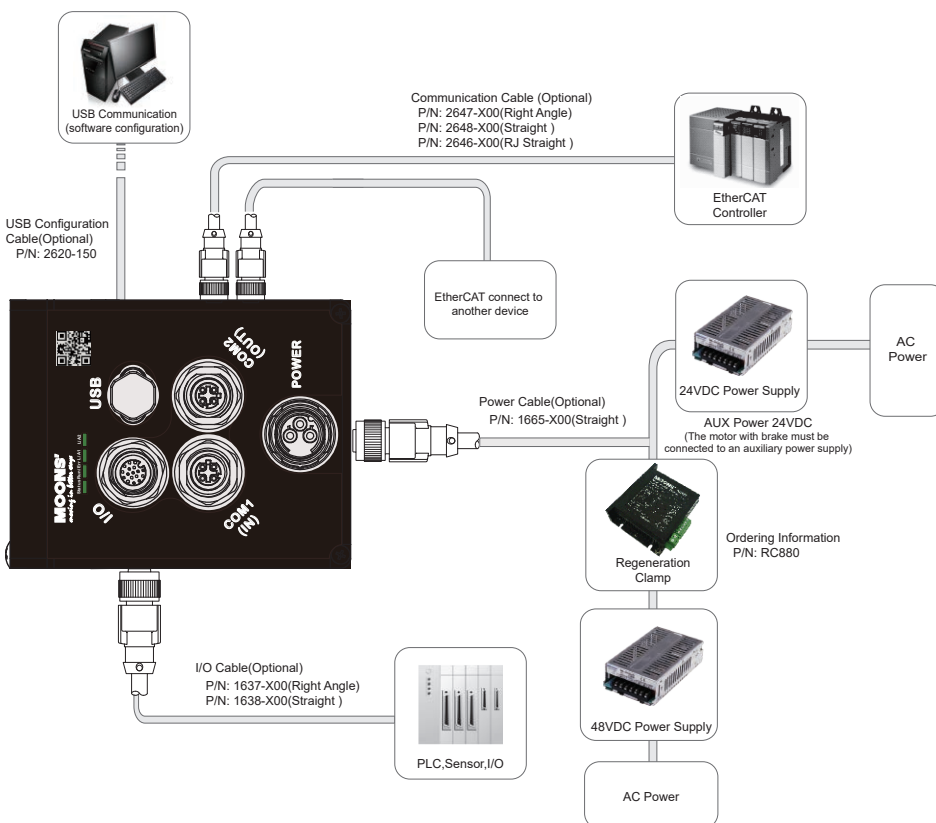

Features

Numbering System

Basic Information

System Configuration

Accessories

Ordering Information

IP20 Type Accessories (For MDXR4/MDXR6/MDXR8)

USB Cable

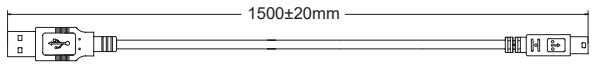
P/N	Length (L)	Description	Outline
2620-150	1.5m	USB configuration cable connect with PC and servo drive	

I/O Cable (Shielded, Only for MDXR4)

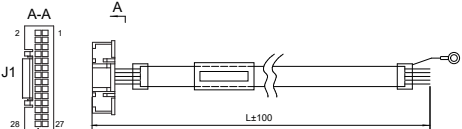
P/N	Length (L)	Outline
1664-100	1m	
1664-200	2m	
1664-300	3m	
1664-500	5m	

I/O Cable (Unshielded, Only for MDXR6/MDXR8)

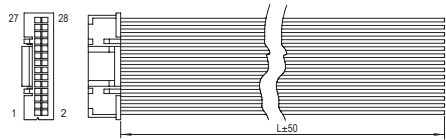
P/N	Length (L)	Outline
1101-100	1m	
1101-200	2m	
1101-500	5m	

I/O Cable (Shielded, Only for MDXR6/MDXR8)

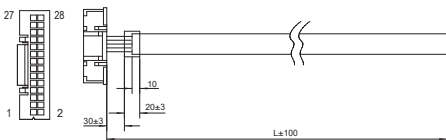
P/N	Length (L)	Outline
1116-100	1m	
1116-200	2m	
1116-300	3m	
1116-500	5m	

CANopen/RS485 Daisy Chain Communication Cable

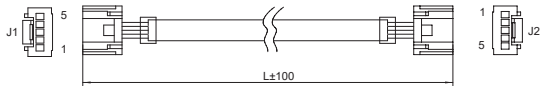
P/N	Length (L)	Outline
2111-025	0.25m	
2111-050	0.5m	
2111-100	1m	
2111-300	3m	
2111-500	5m	

IP65 Type Accessories (For MDXT4)

USB Cable

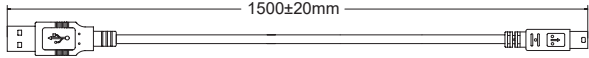
P/N	Length (L)	Description	Outline
2620-150	1.5m	USB configuration cable connect with PC and servo drive	

I/O Cable

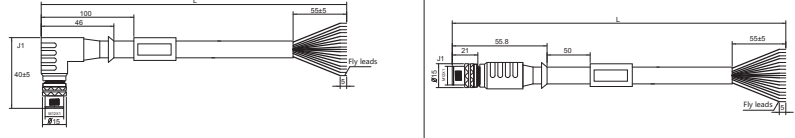
Right Angle Type	Straight Type	Length (L)	Outline
1637-100	1638-100	1m	
1637-200	1638-200	2m	

Power Cable

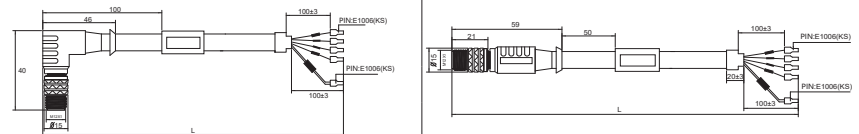
Right Angle Type	Straight Type	Length (L)	Outline
1636-100	1639-100	1m	
1636-200	1639-200	2m	
1636-300	1639-300	3m	
1636-500	1639-500	5m	

CANopen/RS485 Daisy Chain Communication Cable

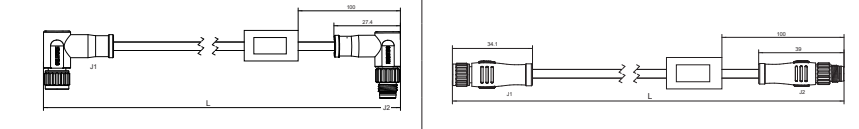
Right Angle Type	Straight Type	Length (L)	Outline
2662-100	2661-100	1m	
2662-200	2661-200	2m	
2662-300	2661-300	3m	
2662-500	2661-500	5m	

EtherCAT Daisy Chain Communication Cable

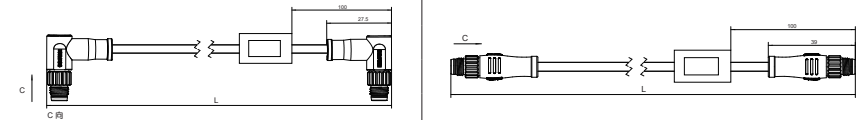
Right Angle Type	Straight Type	Length (L)	Outline
2664-100	2663-100	1m	
2664-200	2663-200	2m	
2664-300	2663-300	3m	
2664-500	2663-500	5m	

EtherCAT Communication Cable

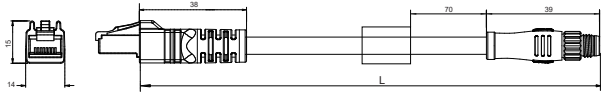
RJ45- Right Angle Type	Length (L)	Outline
2665-200	2m	
2665-300	3m	
2665-500	5m	

Water-proof Cap

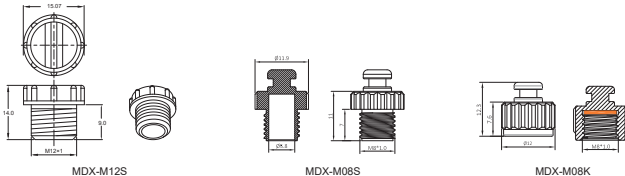
P/N	Description	Outline
MDX-M12S	External thread (I/O)	
MDX-M08S	External thread (COM1)	
MDX-M08K	Inner thread (COM2)	

Terminal matching resistor

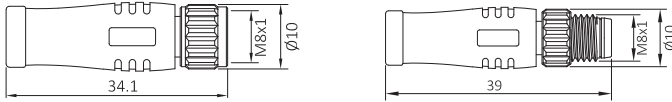
P/N	Description	Outline
MDX-FCTR-08	CANopen Female (COM2)	
MDX-MCTR-08	CANopen Male (COM2)	
MDX-FRTR-08	RS485 Female (COM2)	
MDX-MRTR-08	RS485 Male (COM1)	

Features

Numbering System

Basic Information

System Configuration

Accessories

Ordering Information

IP65 Type Accessories (For MDXT6)

USB Cable

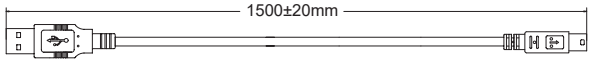
P/N	Length (L)	Description	Outline
2620-150	1.5m	USB configuration cable connect with PC and servo drive	

I/O Cable

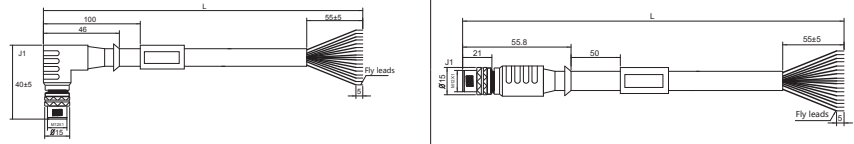
Right Angle Type	Straight Type	Length (L)	Outline
1637-100	1638-100	1m	
1637-200	1638-200	2m	

Power Cable

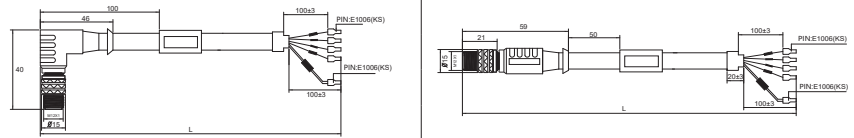
Right Angle Type	Straight Type	Length (L)	Outline
1636-100	1639-100	1m	
1636-200	1639-200	2m	
1636-300	1639-300	3m	
1636-500	1639-500	5m	

CANopen/RS485 Daisy Chain Communication Cable

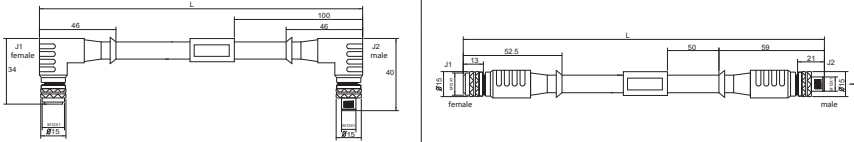
Right Angle Type	Straight Type	Length (L)	Outline
2632-100	2634-100	1m	
2632-200	2634-200	2m	
2632-300	2634-300	3m	
2632-500	2634-500	5m	

EtherCAT Daisy Chain Communication Cable

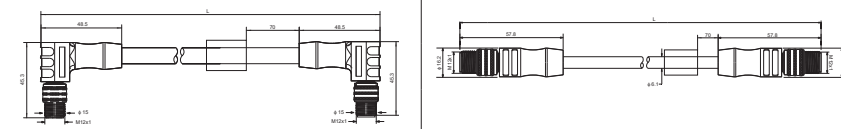
Right Angle Type	Straight Type	Length (L)	Outline
2647-200	2648-200	2m	
2647-300	2648-300	3m	
2647-500	2648-500	5m	

EtherCAT Communication Cable

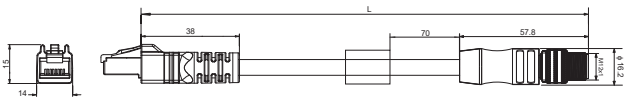
RJ45- Right Angle Type	Length (L)	Outline
2646-200	2m	
2646-300	3m	
2646-500	5m	

Water-proof Cap

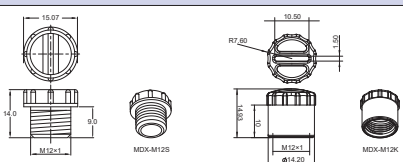
P/N	Description	Outline
MDX-M12S	External thread (I/O, COM1)	
MDX-M12K	Inner thread (COM2)	

Terminal matching resistor

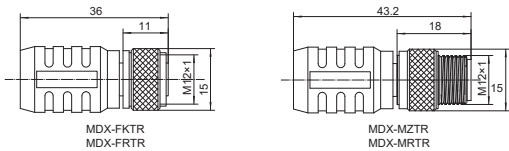
P/N	Description	Outline
MDX-FKTR	CANopen Female (COM2)	
MDX-MZTR	CANopen Male (COM1)	
MDX-FRTR	RS485 Female (COM2)	
MDX-MRTR	RS485 Male (COM1)	

IP65 Type Accessories (For MDXT8)

USB Cable

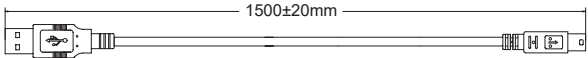
P/N	Length (L)	Description	Outline
2620-150	1.5m	USB configuration cable connect with PC and servo drive	

I/O Cable

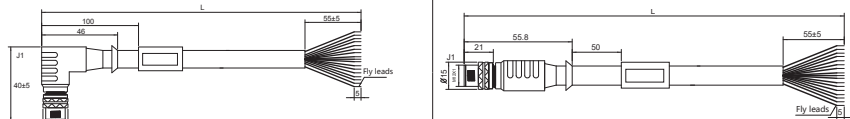
Right Angle Type	Straight Type	Length (L)	Outline
1637-100	1638-100	1m	
1637-200	1638-200	2m	

Power Cable

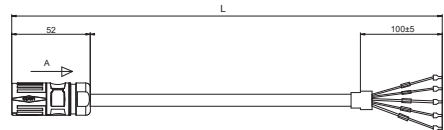
Right Angle Type	Length (L)	Outline
1665-100	1m	
1665-200	2m	
1665-300	3m	
1665-500	5m	

CANopen/RS485 Daisy Chain Communication Cable

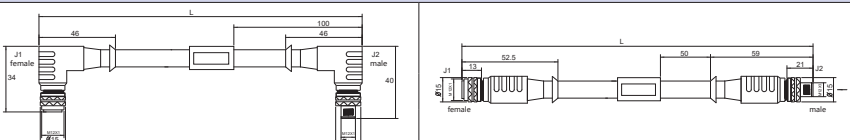
Right Angle Type	Straight Type	Length (L)	Outline
2632-100	2634-100	1m	
2632-200	2634-200	2m	
2632-300	2634-300	3m	
2632-500	2634-500	5m	

EtherCAT Daisy Chain Communication Cable

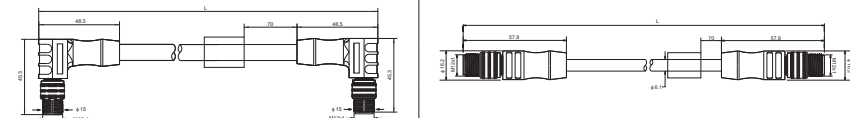
Right Angle Type	Straight Type	Length (L)	Outline
2647-200	2648-200	2m	
2647-300	2648-300	3m	
2647-500	2648-500	5m	

EtherCAT Communication Cable

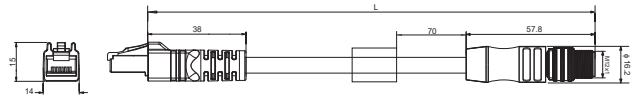
RJ45- Right Angle Type	Length (L)	Outline
2646-200	2m	
2646-300	3m	
2646-500	5m	

Water-proof Cap

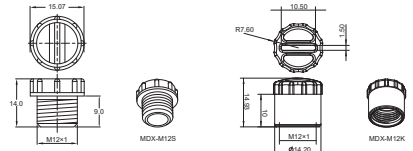
P/N	Description	Outline
MDX-M12S	External thread (I/O, COM1)	
MDX-M12K	Inner thread (COM2)	

Terminal matching resistor

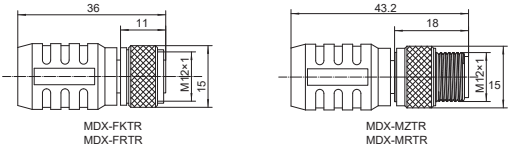
P/N	Description	Outline
MDX-FKTR	CANopen Female(COM2)	
MDX-MZTR	CANopen Male(COM1)	
MDX-FRTR	RS485 Female (COM2)	
MDX-MRTR	RS485 Male (COM1)	

Ordering Information

Part Number	Frame Size	IP Type	Power	Communications	Encoder Type	Brake		
MDXR42JNLRCA000	40mm	IP20	100W	RS-485 CANopen Pulse	L	N		
MDXR42J5LRCA000						5		
MDXR42JNBRCRCA000						N		
MDXR42J5BRCA000						5		
MDXT42JNLRCA000				IP65	RS-485 CANopen Pulse	L	N	
MDXT42J5LRCA000						5		
MDXT42JNBRCRCA000						N		
MDXT42J5BRCA000						5		
MDXT42JNLECA000					EtherCAT	L	N	
MDXT42J5LECA000						5		
MDXT42JNBECRCA000						N		
MDXT42J5BECRCA000						5		
MDXR61GNLRCA000	60mm	IP20	200W	RS-485 CANopen Pulse	L	N		
MDXR61G5LRCA000						5		
MDXR61GNBRCA000						N		
MDXR61G5BRCA000						5		
MDXT61GNLRCA000		IP65		RS-485 CANopen Pulse	L	N		
MDXT61G5LRCA000						5		
MDXT61GNBRCA000						N		
MDXT61G5BRCA000						5		
MDXT61GNLECA000				EtherCAT	L	N		
MDXT61G5LECA000						5		
MDXT61GNBECRCA000						N		
MDXT61G5BECRCA000						5		
MDXR62GNLRCA000		60mm		IP20	400W	RS-485 CANopen Pulse	L	N
MDXR62G5LRCA000								5
MDXR62GNBRCA000								N
MDXR62G5BRCA000								5
MDXT62GNLRCA000				IP65		RS-485 CANopen Pulse	L	N
MDXT62G5LRCA000								5
MDXT62GNBRCA000			N					
MDXT62G5BRCA000			5					
MDXT62GNLECA000	EtherCAT		L			N		
MDXT62G5LECA000						5		
MDXT62GNBECRCA000						N		
MDXT62G5BECRCA000						5		
MDXR82GNLRCA000	80mm	IP20	550W	RS-485 CANopen Pulse	L	N		
MDXR82G5LRCA000						5		
MDXR82GNBRCA000						N		
MDXR82G5BRCA000					5			
MDXR82GNLECA000				EtherCAT	L	N		
MDXR82G5LECA000						5		
MDXR82GNBECRCA000					N			
MDXR82G5BECRCA000		IP65		RS-485 CANopen Pulse	L	N		
MDXT82GNLRCA000						5		
MDXT82G5LRCA000						N		
MDXT82GNBRCA000					5			
MDXT82G5BRCA000					N			
MDXT82G5BRCA000			5					

Note: B: 17-bit Battery-less Absolute Multi-turn Encoder ; L: 17-bit Incremental magnetic encoder;
N: No brake, Low inertia; 5: With brake, Low inertia

Customer Service Center



+86-400-820-9661

■ MOONS' Headquarter

168 Mingjia Road, Minhang District, Shanghai 201107, P.R. China

■ MOONS' Taicang

No. 18 Yingang Rd, Fuqiao Town, Taicang City Jiangsu Province, 215434, P.R. China

■ Domestic Offices

Shenzhen

Room 3901, Building A, Zhongguan Times Square, No. 4168 Liuxian Avenue, Nanshan District, Shenzhen, Guangdong Province, 518000, P.R. China

Beijing

Room 1206, Jing Liang Mansion, No. 16 Middle Road of East, 3rd Ring, Chaoyang District, Beijing 100022, P.R. China

Nanjing

Room 1101-1102, Building 2, New Town Development Center, No. 126 Tianyuan Road, Moling Street, Jiangning District, Jiangsu Province, China, 211106, P.R. China

Qingdao

Rm 1913, Scientific and Technological Innovation Building, Floor 19, No. 171, ShanDong Road, Shibei District, QingDao, Shandong Province, 266033, P.R. China

Wuhan

Room 3001, World Trade Tower, 686 Jiefang Avenue, Jiangnan District, Wuhan, Hubei Province, 430022, P.R. China

Chengdu

Room. 3907, Maoye Plaza, No. 19, Dongyu Street, Jinjiang District, Chengdu Sichuan Province, 610066, P.R. China

Xi'an

Room 1006, Tower D, Wangzuo International City, 1 Tangyan Road, Xi'an, Shanxi Province, 710065, P.R. China

Ningbo

Rm 309, Tower B, Taifu Plaza, 565 Jiangjia Road, Jiangdong District, Ningbo, Zhejiang Province, 315040, P.R. China

Guangzhou

Rm 4006, Tower B, China Shine Plaza, 9 Linhe Xi Road, Tianhe District, Guangzhou, Guangdong Province, 510610, P.R. China

Chongqing

Room. 2108, South yuanzhu Building 20, No. 18 Fuquan Rd., Jiangbei District, Chongqing, 400000, P.R. China

Hefei

Room 1521, Building B, CBC Tuoji Plaza, Jinggang Road, Shushan District, Hefei, Anhui Province, 230088, P.R. China

Suzhou

Rm 1103-1105, North Building 4, Huizu Plaza, 758 Nanhuan East Rd, Gusu District, Suzhou, Jiangsu Province, 215007, P.R. China

Dongguan

Room. 1106-1207, Building 5, Linrunzhigu, No. 1 RD 5th Rd, Songshan Lake, Dongguan, Guangdong Province, 523000, P.R. China

■ North America Company

MOONS' Industries (AMERICA), Inc. (Chicago)

1113 North Prospect Avenue, Itasca, IL 60143, USA

MOONS' INDUSTRIES (AMERICA), INC. (Boston)

36 Cordage Park Circle, Suite 310 Plymouth, MA 02360, USA

APPLIED MOTION PRODUCTS, INC. (Morgan Hill)

18645 Madrone Parkway, Morgan Hill, CA 95037, USA

LIN ENGINEERING, INC. (Morgan Hill)

16245 Vineyard Blvd., Morgan Hill, CA 95037, USA

■ European Company

MOONS' INDUSTRIES (EUROPE) S.R.L.

Via Torri Bianche n.1 20871 Vimercate(MB) Italy

AMP & MOONS' AUTOMATION (GERMANY) GMBH

Kaiserhofstr. 15

60313 Frankfurt am Main Germany

Technosoft SA

Avenue des Alpes 20

CH 2000 Neuchâtel Switzerland

MOONS' INDUSTRIES (UK), LIMITED

Reading, Berkshire, UK

■ Singapore Company

MOONS' INDUSTRIES (SOUTH-EAST ASIA) PTE. LTD.

33 Ubi Avenue 3 #08-23 Vertex Singapore 408868

■ Japan Company

MOONS' INDUSTRIES JAPAN CO., LTD.

Room 602, 6F, Shin Yokohama Koushin Building,

2-12-1, Shin-Yokohama, Kohoku-ku, Yokohama,

Kanagawa, 222-0033, Japan

■ India Company

MOONS' INTELLIGENT MOTION SYSTEM INDIA PVT. LTD.

Rm. 908, 9th Floor, Amar Business Park,

Tal. Haveli, Baner, Pune-411045, Maharashtra, India

■ Vietnam Company

MOONS' INDUSTRIES (VIETNAM) CO., LTD.

Factory C1&D1, Lot IN3-11*A, VSIP Hai Phong Industrial

Park in Dinh Vu - Cat Hai Economic Zone, Lap Le Commune,

Thuy Nguyen District, Hai Phong City, Vietnam 04359



<https://www.moonsindustries.com/>

E-mail: ama-info@moons.com.cn

MOONS'
moving in better ways



- All the specifications, technical parameters of the products provided in this catalog are for reference only, subject to change without notice. For the latest details, please contact our sales department.