

Linear system **LSZ 60, 80, 100**



BELT DRIVE

INDEPENDENT INSTALLATION POSITION

LONG TRAVERSE PATH > 6000 MM

HIGH TORQUE ABSORPTION

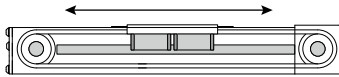
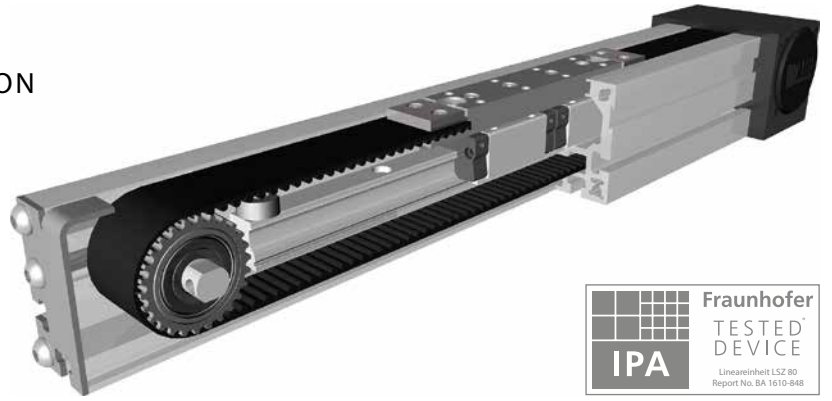

Function:

The guide body consists of an aluminium square profile with an integrated rail guide. The carriage is moved by means of a revolving interior timing belt. At the front face there is a timing belt deflection unit with integrated coupling claws integrated on two sides. The opposite front face is provided with a plate containing a tensioning device for the timing belt. With this series, multi-part assembled units with long strokes can be realized.

Mounting position:

Variable, max. one-piece-length: 6.000 mm.

Carriage connection:

By threaded holes.

Fixation:

By T-slots and mounting sets. The linear axis can be combined with any T-slot profile.

Timing belt:

HTD with reinforcing steel mesh, no backlash when changing direction, repeatability ± 0.1 mm.

Carriage support:

In the standard version the carriage is positioned on two runner blocks which can be readjusted and maintained at each central servicing position. Two grease nipples at the carriage enable relubrication of the positioning system.

Forces and torques	Size	60		80		100	
	permitted dyn. Forces*	5000 km	10000 km	5000 km	10000 km	5000 km	10000 km
F_x (N)		1073	960	1900	1800	4000	3800
F_y (N)		1410	990	3570	2550	4080	2900
F_z (N)		3520	2500	8500	6050	10300	7270
M_x (Nm)		33	23	107	75	142	101
M_y (Nm)		104	73	310	222	439	311
M_z (Nm)		100	70	296	210	412	292
All forces and torques related to the following:							
existing values $\frac{F_y}{F_{y_{dyn}}} + \frac{F_z}{F_{z_{dyn}}} + \frac{M_x}{M_{x_{dyn}}} + \frac{M_y}{M_{y_{dyn}}} + \frac{M_z}{M_{z_{dyn}}} \leq 1$							
table values $\frac{F_y}{F_{y_{dyn}}} + \frac{F_z}{F_{z_{dyn}}} + \frac{M_x}{M_{x_{dyn}}} + \frac{M_y}{M_{y_{dyn}}} + \frac{M_z}{M_{z_{dyn}}} \leq 1$							
No-load torque							
Nm		0,6		1,0		1,8	
Speed							
(m/s) max		5		5		5	
Geometrical moments of inertia of aluminium profile							
I_x mm ⁴		4,37x10 ⁵		14,6x10 ⁵		35,51x10 ⁵	
I_y mm ⁴		5,78x10 ⁵		17,1x10 ⁵		46,41x10 ⁵	
Elastic modulus N/mm ²		70000		70000		70000	

For life-time calculation use our homepage.

* referred to life-time

Driving torque:

$$M_o = \frac{F \cdot P \cdot S_i}{2000 \cdot \pi} + M_n$$

$$P_o = \frac{M_o \cdot n}{9550}$$

- F = force (N)
- P = pulley action perimeter (mm)
- S_i = safety factor 1,2 ... 2
- M_n = no-load torque (Nm)
- n = rpm pulley (min⁻¹)
- M_o = driving torque (Nm)
- P_o = motor power (KW)

Deflection:

$$f = \frac{F \cdot L^3}{E \cdot I \cdot 192}$$

- f = deflection (mm)
- F = load (N)
- L = free length (mm)
- E = elastic modulus 70000 (N/mm²)
- I = second moment of area (mm⁴)

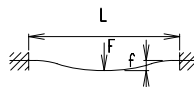

Linear system **LSZ 60, 80, 100**

Dimensions (mm)

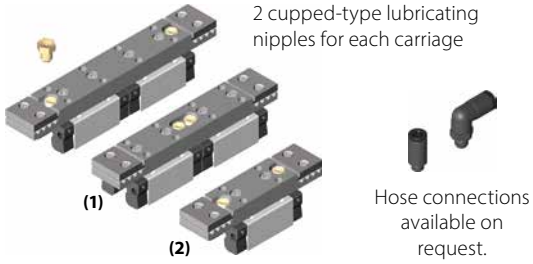
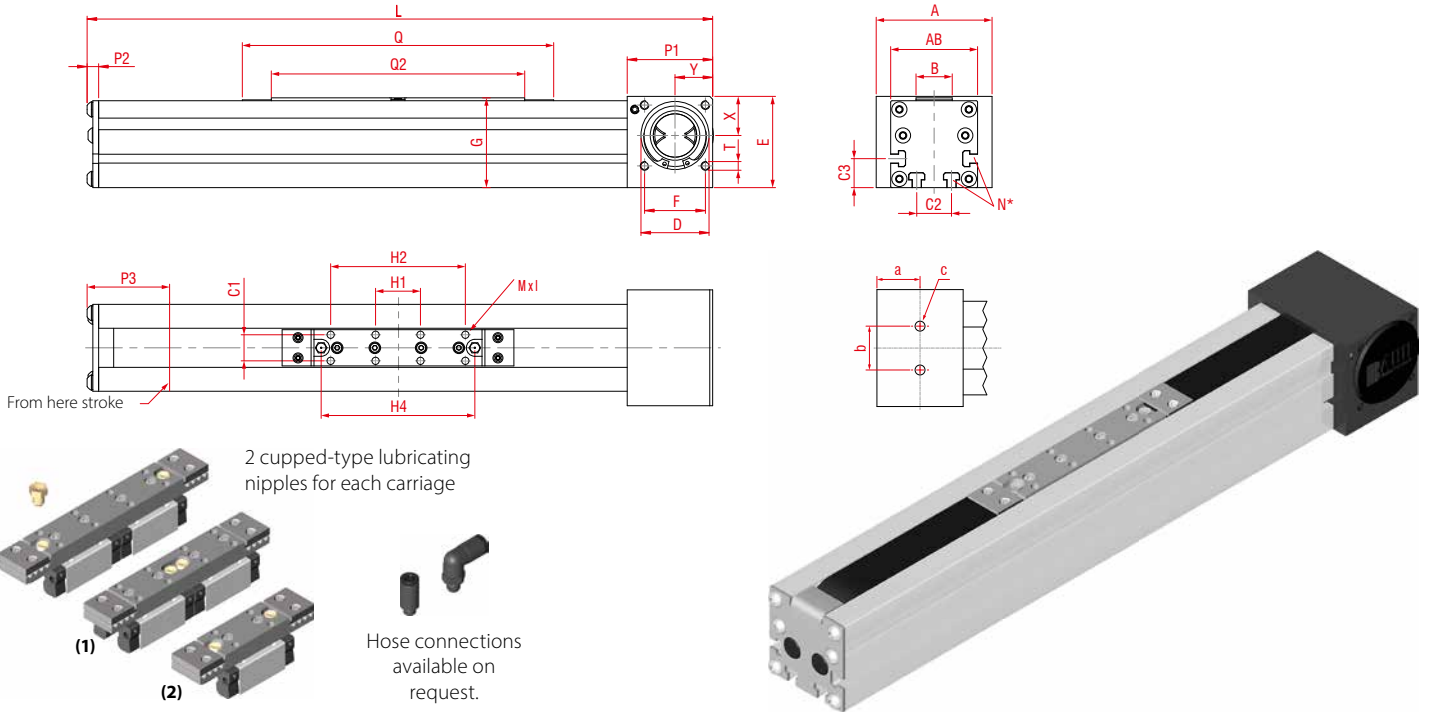

Size	A	AB	B	C1	C2	C3	D -0,05	E	F	G	MxI	N for	P1	P2	P3	T	X	Y	a	b	c	Weight per 100 mm
LSZ 60	80	60	25	18	24	20	47	63	42	62,5	M6x10	M5	59	6	55	M6	27	26	29,5	30	M8	0,53 kg
LSZ 80	100	80	25	18	30	22	68	93	60	83	M6x12	M6	90	8	73	M8	45	40	47,5	40	M10	0,87 kg
LSZ 100	130	100	42	30	40	30	90	110	80	103	M8x12	M8	110	11	109	M10	49,4	50	55	50	M12	1,35 kg

0 Choice of guide body profile:
(0) Standard **(1)** corrosion-protected screws
(4) expanded corrosion-protected version
 (depending on the availability of components)

Carriage		L	Q	Q2	H1	H2	H4	Basic weight System
LS 60	Version (0)	274	160	116	31	93	106	3,06 kg
	Version (1)	254	140	96	32	84	10	2,62 kg
	Version (2)	214	100	56	31	--	48	2,07 kg
LS 80	Version (0)	382	219	149	40	120	133	7,69 kg
	Version (1)	367	204	134	40	120	12,5	7,41 kg
	Version (2)	310	147	77	40	--	60,5	6,39 kg
LS 100	Version (0)	470	251	180	33	99	172	12,43 kg
	Version (1)	455	235	164	83	149	18	12,20 kg
	Version (2)	370	151	80	66	--	69	10,43 kg

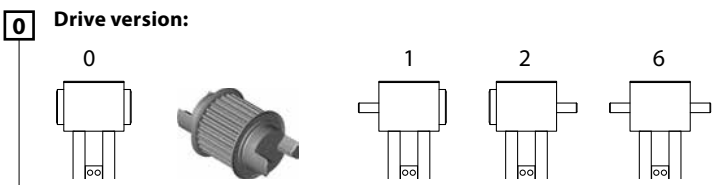
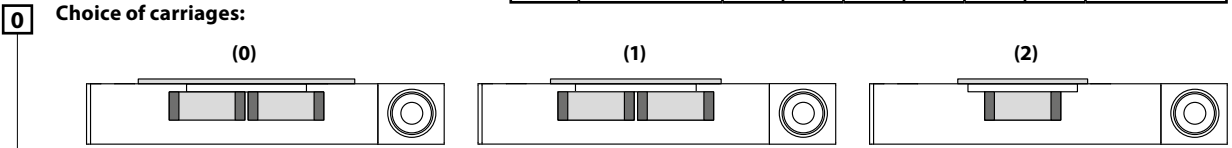

Belt table:

Code No.	Size	Belt	mm/rev.	Number of teeth
0 3	60	5M 30	130	26
0 4	80	8M 30	176	22
0 7	100	8M 50	224	28

Shaft dimensions / Coupling claw:

Size	Shaft Ø h6 x length	Feather key	Coupling
60	14 x 35	5x5x28	14
80	18 x 45	6x6x40	19
100	22 x 45	6x6x40	24

LSZ 60 1 0 0 0 0 3 1 1500 — Basic length + stroke = total length
 Pos. 1 2 3 4 5 6 7

Sample ordering code:
 LSZ60, standard body profile, standard carriage, double-sided coupling claw, 1226 mm stroke



en 21.06.731.B

Our policy is one of continued research and development.
 We therefore reserve the right to amend, without notice, the specifications
 given in this document. (2023-9481) © 2023 Bahr Modultechnik GmbH