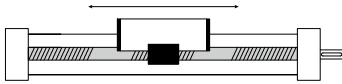
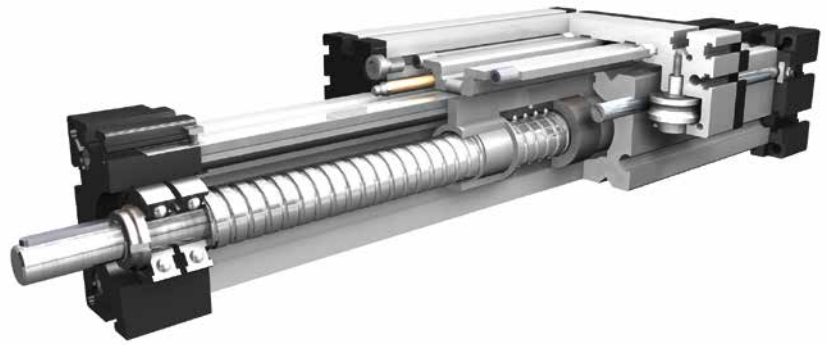

## SPINDLE DRIVEN

 LIFTING SYSTEM

 PRECISION
**Function:**

This linear unit consists of an aluminium hollow section with integral, parallel ground and hardened steel guide rods. The carriage has play-adjustable ball-bearing rollers which engage with the guide rods. The rotating trapezoidal/ballscrew causes linear motion of the ballnut, which is connected to the carriage. The slot necessary for this is covered by a stainless steel strip, making the unit dust- and splash-proof. Lateral adjustment of movement for parallel units, or when two carriages are mounted on one unit, is provided by the ballnut mounting.

**Fitting position:** As required, max. length 3.000 mm  
(**EL 30** / max. 1500 mm, **EL 40** / max. 2000 mm)

**Carriage mounting:** By T-slots and tapped holes

**Unit mounting:** By T-slots and tapped holes in the mounting surfaces.

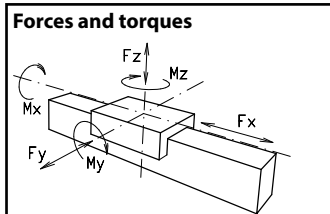

Size	EL 30		EL 40		EL 60		EL 60 S		EL 80		EL 80S		EL 100		EL 125	
Forces/Torques	static	dyna.	static	dyna.	static	dyna.	static	dyna.	static	dyna.	static	dyna.	static	dyna.	static	dyna.
$F_x$ (N)	750	600	1500	1200	2500	2000	2500	2000	5000	4000	5000	4000	10000	8000	15000	12000
$F_y$ (N)	90	60	1200	700	3000	2000	4100	3100	3000	2000	4600	3600	8000	6500	12000	9000
$F_z$ (N)	90	60	900	650	1700	1100	2160	1600	1700	1100	3000	1800	3600	2200	6000	4500
$M_x$ (Nm)	12	10	25	20	67	43	88	65	90	55	170	140	300	230	600	450
$M_y$ (Nm)	12	10	32	18	90	70	190	140	110	80	270	230	400	270	750	600
$M_z$ (Nm)	15	12	35	25	120	100	230	170	150	120	300	220	750	500	1350	1150

**All forces and torques relate to the following:**

$$\frac{F_y}{F_{y_{dyn}}} + \frac{F_z}{F_{z_{dyn}}} + \frac{M_x}{M_{x_{dyn}}} + \frac{M_y}{M_{y_{dyn}}} + \frac{M_z}{M_{z_{dyn}}} \leq 1$$

**No-load torque**

	EL 30	EL 40	EL 60	EL 60 S	EL 80	EL 80S	EL 100	EL 125
Trapezoidal thread	10x3	18x4/18x8	24x5/24x10	24x5/24x10	28x5/28x10	28x5/28x10	32x6/32x12	40x7/40x14
(Nm)	0,3	0,4/0,5	0,6/0,8	0,6/0,8	0,8/1,0	0,8/1,0	0,9/1,1	1,2/1,4
Ballscrew	8x2,5	16x5/16x10	25x5/25x10	25x5/25x10	32x5/32x10	32x5/32x10	32x5/32x10	40x10/40x20
(Nm)	0,15	0,2/0,4	0,4/0,6	0,4/0,6	0,6/0,8	0,6/0,8	0,7/0,9	1,0/1,2

**Geometrical moments of inertia of aluminium profile**

	EL 30	EL 40	EL 60	EL 60 S	EL 80	EL 80S	EL 100	EL 125
$I_x$ mm <sup>4</sup>	4,09x10 <sup>4</sup>	1,32x10 <sup>5</sup>	6,79x10 <sup>5</sup>	6,79x10 <sup>5</sup>	18,99x10 <sup>5</sup>	18,99x10 <sup>5</sup>	44,4x10 <sup>5</sup>	101,5x10 <sup>5</sup>
$I_y$ mm <sup>4</sup>	4,00x10 <sup>4</sup>	1,34x10 <sup>5</sup>	6,97x10 <sup>5</sup>	6,97x10 <sup>5</sup>	18,97x10 <sup>5</sup>	18,97x10 <sup>5</sup>	44,8x10 <sup>5</sup>	101,5x10 <sup>5</sup>
E-Modulus N/mm <sup>2</sup>	70000	70000	70000	70000	70000	70000	70000	70000

For life-time calculation of rollers use our homepage.

Driving torque:

$$M_a = \frac{F \cdot P \cdot S_i}{2000 \cdot \pi \cdot \mu} + M_n$$

$$P_a = \frac{M_a \cdot n}{9550}$$

$F$  = force (N)  
 $P$  = thread pitch (mm)  
 $S_i$  = safety factor 1,2 ... 2  
 $M_n$  = no-load torque (Nm)  
 $n$  = rpm of screw (min<sup>-1</sup>)  
 $M_a$  = driving torque (Nm)  
 $\mu$  = screw efficiency  
 $P_a$  = motor power (KW)

Efficiency of lead screws:

All ballscrew 0,900

Tr 10x3	0,375	Tr 32x6	0,360
Tr 18x4	0,399	Tr 32x12	0,524
Tr 18x8	0,565	Tr 40x7	0,344
Tr 24x5	0,384	Tr 40x14	0,509
Tr 24x10	0,550		
Tr 28x5	0,349		
Tr 28x10	0,513		

Deflection:

$$f = \frac{F \cdot L^3}{E \cdot I \cdot 192}$$

$f$  = deflection (mm)  
 $F$  = load (N)  
 $L$  = free length (mm)  
 $E$  = elastic modulus 70000 (N/mm<sup>2</sup>)  
 $I$  = second moment of area (mm<sup>4</sup>)

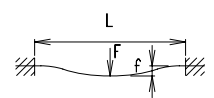

# Linear system ELT/ELK 30, 40, 60, 60S, 80, 80S, 100, 125

Dimensions (mm)



Increasing the carriage length will increase the basic length by the same amount.

Size	Basic length L	A	B	C	D ±0,05	E	F	G	H	J	K	MM for	NN for	OO for	P	Q	R	S Ø h6 x length	T	Basic weight	Weight per 100 mm
EL 30	120	70	56	42	40x1	13	35	-	-	26	47	-	M 6	M 6	18	82	-	5x15	4,2	0,7 kg	0,16 kg
EL 40	175	100	66	58	48x1	18	47	--	-	35	64	-	M 6	M 6	25	122	3x3x25	10x27	6,5	1,7 kg	0,37 kg
EL 60	245	144	96	82	62x1	30	69	-	-	49	90	-	M 8	M 8	35	168	5x5x28	14x35	8,5	5,1 kg	0,89 kg
EL 60S	270	170	108	82	62x1	30	69	-	-	53	94	-	M 8	M 8	35	194	5x5x28	14x35	8,5	5,1 kg	0,89 kg
EL 80	285	170	117	102	80x1	40	88	10,5	30,5	70	121	M 6	M 10	M 10	45	194	6x6x40	18x45	8,5	10,0 kg	1,48 kg
EL 80S	305	190	126	102	80x1	40	88	12,5	30	71	122	M 6	M 10	M 8	45	214	6x6x40	18x45	8,5	11,0 kg	1,48 kg
EL 100	410	230	155	130	110x1	50	112	-	29	89	154	M 10	M 10	M 10	55	300	6x6x40	22x45	10,5	19,0 kg	2,00 kg
EL 125	510	295	200	165	130x1	60	142	-	30	107,5	190	M 10	M 12	M 12	65	365	8x7x50	25x55	13,0	33,0 kg	2,89 kg

**T Spindle:**  
(T) Trapezoidal thread (K) Ballscrew

**1 Selection of screw:**  
(1) right hand (2) left hand (Ballscrew by inquiry)

**0 Choice of guide body profile:**  
(0) Standard (2) corrosion-protected guide rods and screws  
(4) expanded corrosion-protected version, only for trapezoidal thread (on request)

**0 Choice of carriages:**

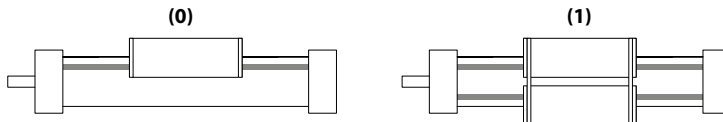

**0 Drive version:**  
(0) one shaft (locating bearing side) (1) one shaft (non-locating bearing side)  
(2) shaft on both sides

Size	Selection of screw:			
	Standard	Multistart screw	Standard	Multistart screw
30	(0) Tr 10x3		(0) Kg 8x2,5	Tr = trapezoidal thread / Kg = ballscrew
40	(0) Tr 18x4	(1) Tr 18x8	(0) Kg 16x5	(1) Kg 16x10 (2) Kg 16x16
60	(0) Tr 24x5	(1) Tr 24x10	(0) Kg 25x5	(1) Kg 20x20 (2) Kg 25x10 (3) Kg 20x50
80	(0) Tr 28x5	(1) Tr 28x10	(0) Kg 32x5	(1) Kg 25x25 (2) Kg 32x10
100	(0) Tr 32x6	(1) Tr 32x12	(0) Kg 32x5	(1) Kg 32x10 (2) Kg 32x20 (3) Kg 32x32
125	(0) Tr 40x7	(1) Tr 40x14	(0) Kg 40x10	(1) Kg 40x20 (2) Kg 40x40

**0 Ballscrew pitch accuracy:**  
(0) 0,05 mm / 300 mm (Standard) (2) 0,025 mm / 300 mm

**0 End play of ball nut:**  
(0) 0,04 mm (Standard), (1) < 0,02 mm, (2) 2% apply prestress

**Repeatability:**  
± 0,2 mm Trapezoidal  
± 0,025 mm Ballscrew

EL T 40 1 0 0 0 0 0 0 1500

Basic length + stroke = total length

Pos. 1 2 3 4 5 6 7

Sample ordering code:

ELT40, trapezoidal right hand thread, standard body profile, top carriage, one shaft (locating bearing side), spindle 18x4, 1325 mm stroke



en 21.06.717.B

Our policy is one of continued research and development. We therefore reserve the right to amend, without notice, the specifications given in this document. (2023-9467) © 2023 Bahr Modultechnik GmbH

SPINDLE DRIVEN - RIGHT-HAND AND LEFT-HAND

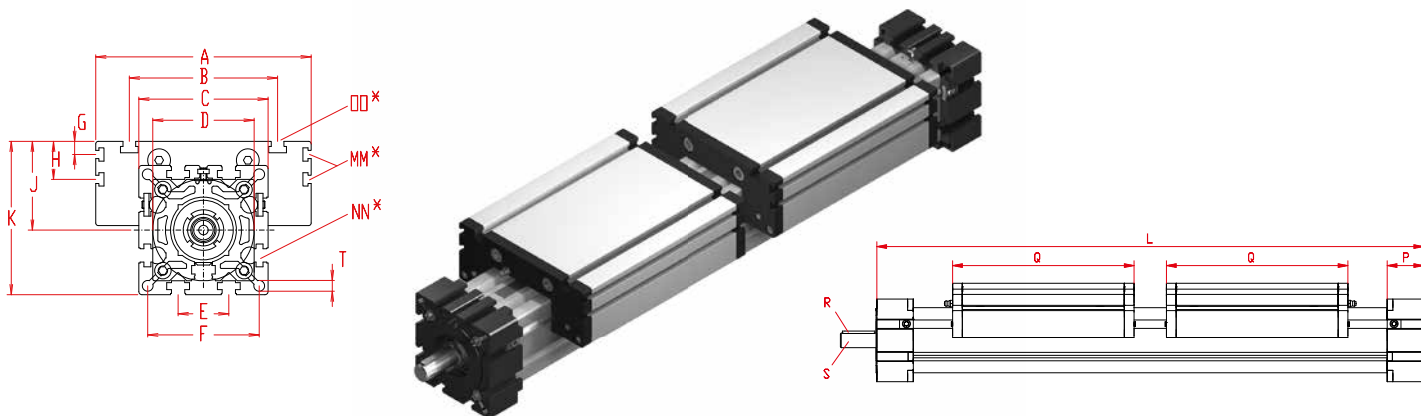

Increasing the carriage length will increase the basic length by the same amount.

Size	Basic length L	A	B	C	D ± 0,05	E	F	G	H	J	K	MM for	NN for	OO for	P	Q	R	S Ø h6 x length	T	Basic weight	Weight per 100 mm
EL 30	202	70	56	42	40x1	13	35	-	-	26	47	-	M 6	M 6	18	82	-	5 x 15	4,2	1,1 kg	0,16 kg
EL 40	300	100	66	58	48x1	18	47	-	-	35	64	-	M 6	M 6	25	122	3x3x25	10 x 27	6,5	2,5 kg	0,37 kg
EL 60	410	144	96	82	62x1	30	69	-	-	49	90	-	M 8	M 8	35	168	5x5x28	14 x 35	8,5	8,1 kg	0,89 kg
EL 60S	460	170	108	82	62x1	30	69	-	-	53	94	-	M 8	M 8	35	194	5x5x28	14 x 35	8,5	10,1 kg	0,89 kg
EL 80	480	170	117	102	80x1	40	88	10,5	30,5	70	121	M 6	M 10	M 10	45	194	6x6x40	18 x 45	8,5	15,0 kg	1,48 kg
EL 80S	520	190	126	102	80x1	40	88	12,5	30	71	122	M 6	M 10	M 8	45	214	6x6x40	18 x 45	8,5	17,0 kg	1,48 kg
EL 100	720	230	155	130	110x1	50	112	-	29	89	154	M 10	M 10	M 10	55	300	6x6x40	22 x 45	10,5	32,0 kg	2,00 kg
EL 125	880	295	200	165	130x1	60	142	-	30	107,5	190	M 10	M 12	M 12	65	365	8x7x50	25 x 55	13	48,0 kg	2,89 kg

**T Spindle:**  
(T) Trapezoidal thread (K) Ballscrew

**3 Selection of screw:**  
(3) right - left hand (4) divided spindle

**0 Choice of guide body profile:**  
(0) Standard (2) corrosion-protected guide rods and screws  
(4) expanded corrosion-protected version, only for trapezoidal thread (on request)

**0 Choice of carriages:**

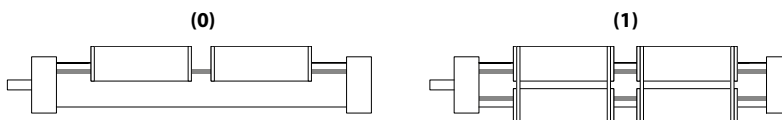

**0 Drive version:**  
(0) shaft right hand thread (1) shaft left hand thread (2) shaft on both sides

Selection of screw:				
Size	Standard	Multistart screw	Standard	Multistart screw
30	(0) Tr 10x3		(0) Kg 8x2,5*	Tr = trapezoidal thread / Kg = ballscrew
40	(0) Tr 18x4	(1) Tr 18x8	(0) Kg 16x5	(1) Kg 16x10* (2) Kg 16x16*
60	(0) Tr 24x5	(1) Tr 24x10	(0) Kg 25x5	(1) Kg 20x20* (2) Kg 25x10*
80	(0) Tr 28x5	(1) Tr 28x10	(0) Kg 32x5	(1) Kg 25x25* (2) Kg 32x10*
100	(0) Tr 32x6	(1) Tr 32x12	(0) Kg 32x5	(1) Kg 32x10* (2) Kg 32x20* (3) Kg 32x32*
125	(0) Tr 40x7	(1) Tr 40x14	(0) Kg 40x10	(1) Kg 40x20* (2) Kg 40x40*

\* = only for selection of devided spindle

**0 Ballscrew pitch accuracy:**  
(0) 0,05 mm / 300 mm (Standard) (2) 0,025 mm / 300 mm

**0 End play of ball nut:**  
(0) 0,04 mm (Standard), (1) < 0,02 mm, (2) 2% apply prestress

**Repeatability:**  
± 0,2 mm Trapezoidal  
± 0,025 mm Ballscrew

**EL T 40 3 0 0 0 0 0 0 2200** Basic length + stroke = total length

Sample ordering code:  
ELT40, trapezoidal right - left hand thread, standard body profile, 2 top carriage, shaft on right hand side, spindle 18x4, 1900 mm stroke