

BELT DRIVE - EX GUIDE

 **UNIVERSAL SYSTEM**

 **EX-GUIDE**

 **HIGH SPEED**

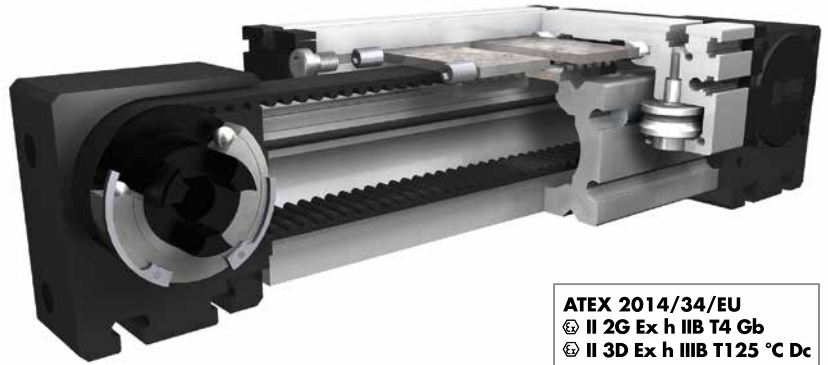

ATEX 2014/34/EU
II 2G Ex h IIB T4 Gb
II 3D Ex h IIB T125 °C Dc



Function:

Like ELZ. The positioning system is suitable for use according to the intended purpose in potentially explosive areas (see ATEX 2014/34/EU marking). An operating manual is included in the scope of delivery. The system is certified for the following areas:

ATEX 2014/34/EU II 2G EX h IIB T4 Gb:

All application areas except for underground mining. Gas atmosphere category 2, explosion protection category: protection due to secure construction (design security). Equipment group IIB. Temperature class T4=135°C, EPL Gb.

ATEX 2014/34/EU II 3D EX h IIB T125 °C Dc:

All application areas except for underground mining. Dust atmosphere category 3. Maximum permissible surface temperature: 125°C, EPL Dc.

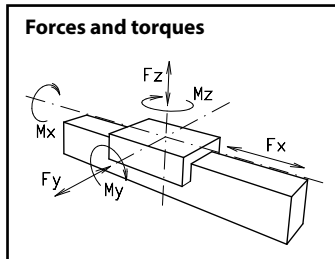

- Fitting position:** As required, max. length 6.000 mm.
- Carriage mounting:** T-slots
- Unit mounting:** By T-slots or tapped holes in the bearing block, mounting sets.
- Belt type:** HTD with steel reinforcement, no backlash when changing direction, repeatability: ± 0,1 mm.

Size	ELZex 40		ELZex 60		ELZex 60 S		ELZex 80		ELZex 80 S		ELZex 100		ELZex 125	
Forces/Torques	static	dynamic	static	dynamic	statisch	dynamic	static	dynamic	static	dynamic	static	dynamic	static	dynamic
F _x (N)	178	142	312	250	312	250	1083	866	1083	866	1127	902	2067	1654
F _y (N)	517	414	1330	1064	1910	1528	1584	1267	2219	1775	3100	2480	4980	3984
F _z (N)	355	284	742	594	935	748	613	490	1052	842	1292	1034	2190	1752
M _x (Nm)	12	10	36	29	52	41	36	29	67	54	101	81	220	176
M _y (Nm)	13	11	39	32	66	53	39	32	87	70	136	109	280	224
M _z (Nm)	19	15	70	56	137	110	100	81	182	146	326	260	636	509

All forces and torques relate to the following
existing values $\frac{F_y}{F_{y_{dyn}}} + \frac{F_z}{F_{z_{dyn}}} + \frac{M_x}{M_{x_{dyn}}} + \frac{M_y}{M_{y_{dyn}}} + \frac{M_z}{M_{z_{dyn}}} \leq 1$
table values

No-load torque							
Nm	0,3	0,6	0,7	0,9	1,2	1,4	1,8
Speed							
(m/s) max	1	1	1	1	1	1	1
Tensile force							
permanent (N)	178	312	312	1083	1083	1127	2067
Geometrical moments of inertia of aluminium profile							
I _x mm ⁴	1,32x10 ⁵	6,79x10 ⁵	6,79x10 ⁵	18,99x10 ⁵	18,99x10 ⁵	44,4x10 ⁵	101,5x10 ⁵
I _y mm ⁴	1,34x10 ⁵	6,97x10 ⁵	6,97x10 ⁵	18,97x10 ⁵	18,97x10 ⁵	44,8x10 ⁵	101,5x10 ⁵
E-Modulus N/mm ²	70000	70000	70000	70000	70000	70000	70000

For life-time calculation of rollers use our homepage.

Driving torque:

$$M_o = \frac{F \cdot P \cdot S_i}{2000 \cdot \pi} + M_n$$

$$P_o = \frac{M_o \cdot n}{9550}$$

- F = force (N)
- P = pulley action perimeter (mm)
- S_i = safety factor 1,2 ... 2
- M_n = no-load torque (Nm)
- n = rpm pulley (min⁻¹)
- M_o = driving torque (Nm)
- P_o = motor power (KW)

Deflection:

$$f = \frac{F \cdot L^3}{E \cdot I \cdot 192}$$

- f = deflection (mm)
- F = load (N)
- L = free length (mm)
- E = elastic modulus 70000 (N/mm²)
- I = second moment of area (mm⁴)

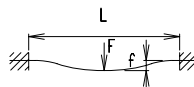

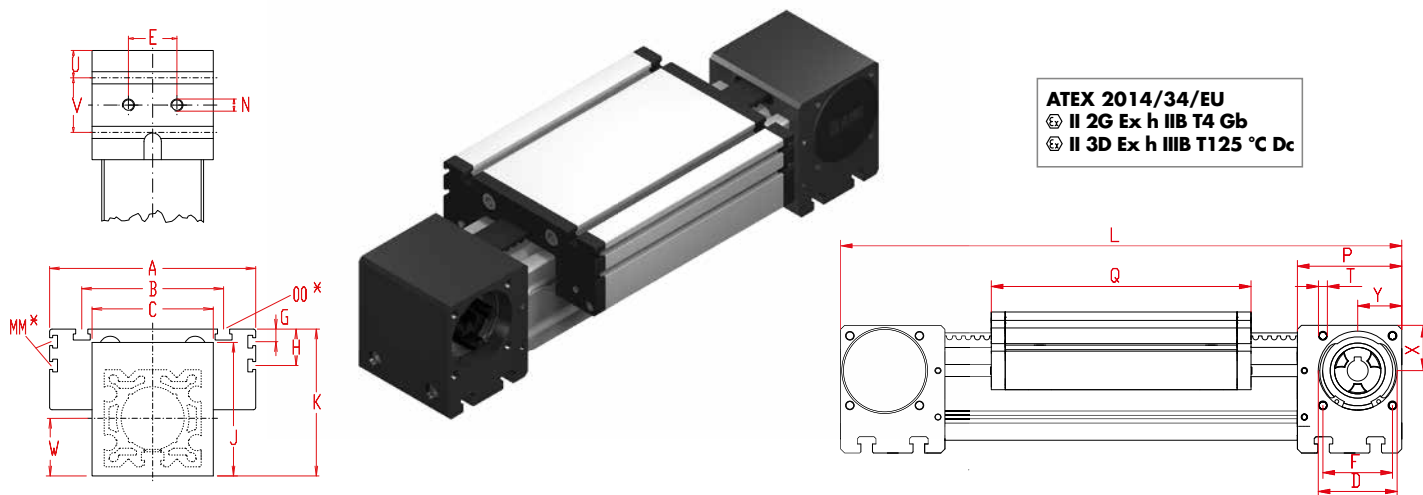

ATEX 2014/34/EU
 Ⓜ II 2G Ex h IIB T4 Gb
 Ⓜ II 3D Ex h IIB T125 °C Dc

Increasing the carriage length will increase the basic length by the same amount.

Size	Basic length L	A	B	C	D -0,05	E	F	G	H	J	K	MM for	N	OO for	P	Q	T	U	V	W	X	Y	Basic weight	Weight per 100 mm
ELZex 40	225	100	66	58	37	18	32	-	-	58	64	-	M 6	M 6	49	122	M 5	12,5	24	29	20,5	20,5	1,9 kg	0,24 kg
ELZex 60	290	144	96	80	47	30	42	-	-	82	90	-	M 8	M 8	59	168	M 6	15	30	41	27	26	4,8 kg	0,62 kg
ELZex 60 S	315	170	108	80	47	30	42	-	-	82	94	-	M 8	M 8	59	194	M 6	15	30	41	27	26	5,8 kg	0,62 kg
ELZex 80	375	170	117	100	68	40	60	10,5	30,5	110	121	M 6	M 10	M 10	90	194	M 8	22,5	45	51	39	38	10,0 kg	1,00 kg
ELZex 80 S	395	190	126	100	68	40	60	12,5	30	110	122	M 6	M 10	M 8	90	214	M 8	22,5	45	51	39	38	11,0 kg	1,00 kg
ELZex 100	530	230	155	130	90	50	80	-	29	135	154	M 10	M 12	M 10	110	300	M 10	23	64	65	50	50	24,0 kg	1,60 kg
ELZex 125	625	295	200	160	110	60	100	-	30	167	191	M 10	M 12	M 12	130	365	M 10	38	50	82	60	60	37,0 kg	2,10 kg

0 Choice of guide body profile:
 (0) Standard (2) corrosion-protected guide rods and screws

0 Choice of carriages:

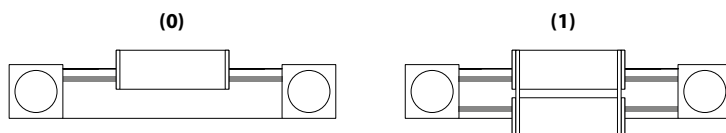

0 Drive version:

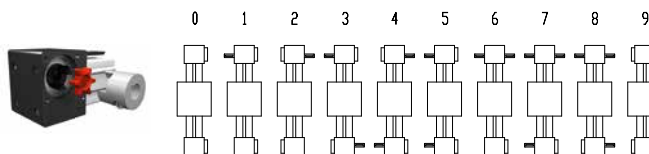

Version 9 is the same as 0, but with double sided coupling claw.

The standard version is supplied without shaft. A shaft can be retrofitted by inserting it into the pulley bore and securing it with 2 locking rings or tension sets (size 100 and 125).

Size	Version 1	
	Q	L
40	138	241
60	184	306
60S	214	335
80	210	391
80S	234	415
100	316	546
125	389	649

Belt table:

Code No.	Size	Belt	mm/rev.	Number of teeth
0 3	40	5M15	100	20
0 4	60 (S)	5M25	130	26
0 7	80 (S)	8M30	192	24
0 9	100	8M50	256	32
1 0	125	8M70	304	38

Shaft dimensions / Coupling claw:

Size	Shaft \varnothing h6 x length	Key	Coupling
40	10 x 27	3x3x22	9
60 (S)	14 x 35	5x5x28	14
80 (S)	18 x 45	6x6x40	19
100	22 x 45	6x6x40	24
125	30 x 55	8x7x50	28

ELZex 40 1 0 0 0 0 3 1 1500 Basic length + stroke = total length

Pos. 1 2 3 4 5 6 7

Sample ordering code:

ELZex 40, standard body profile, standard carriage, coupling claw on one side, 1275 mm stroke.