

Linear system QST/K 60, 80, 100

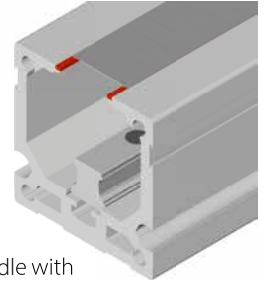

SPINDLE DRIVES

- CLEAN ROOM
- PRECISION

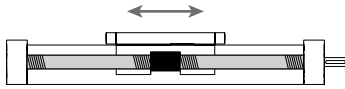

Function:

This unit consists of a square aluminium profile with an integrated ball rail. The carriage is driven by means of a rotating spindle with leading nut. The openings of the guide body are sealed by a stainless steel cover band to protect the drive from splash water and dust. In size 80, the cover tape is additionally secured with magnetic tapes (see detail picture, marked in red). High positioning and repeat accuracy. Inre-stricted installation position, flexible use as a vertical axis in a gantry system with short lifting movements and higher loads. This linear unit is suitable for application in clean rooms of clean-room classification ISO class 1 (according to DIN EN ISO 14644-1).

- Fitting position:** As required, max. length 3000mm
- Carriage connection:** By T-slots
- Unit mounting:** By half round slots and tapped holes in the bearing blocks, mounting sets.

Forces and torques	Size	QST/K 60		QST/K 80		QST/K 100	
	permitted dyn. forces*	5000 km	10000 km	5000 km	10000 km	5000 km	10000 km
	F_x (N)	900	800	2500	2000	5000	4000
	F_y (N)	1415	1010	3570	2542	4082	2910
	F_z (N)	3525	2510	8500	6050	10300	7360
	M_x (Nm)	33	23	107	76	142	101
	M_y (Nm)	190	143	604	430	838	597
	M_z (Nm)	176	125	550	392	745	532
All forces and torques related to the following:							
existing values $\frac{F_y}{F_{y_{dyn}}} + \frac{F_z}{F_{z_{dyn}}} + \frac{M_x}{M_{x_{dyn}}} + \frac{M_y}{M_{y_{dyn}}} + \frac{M_z}{M_{z_{dyn}}} \leq 1$							
table values $\frac{F_y}{F_{y_{dyn}}} + \frac{F_z}{F_{z_{dyn}}} + \frac{M_x}{M_{x_{dyn}}} + \frac{M_y}{M_{y_{dyn}}} + \frac{M_z}{M_{z_{dyn}}} \leq 1$							
No-load torque							
Trapezoidal		18x4/18x8		24x5/24x10		32x6/32x12	
Nm		0,6/0,7		0,6/0,8		1,5/1,7	
Ballscrew		16x5/16x10		25x5/20x20/25x10		32x5/32x10	
Nm		0,4/0,6		0,4/0,7/0,6		1,3/1,6	
Geometrical moments of inertia of aluminium profile							
I_x mm ⁴		4,3x10 ⁵		14,3x10 ⁵		31,8x10 ⁵	
I_y mm ⁴		5,8x10 ⁵		18,7x10 ⁵		46,5x10 ⁵	
E-Modulus N/mm ²		70000		70000		70000	

For life-time calculation use our homepage.

* referred to life-time

Driving torque:

$$M_a = \frac{F \cdot P \cdot S_i}{2000 \cdot \pi \cdot \mu} + M_n$$

$$P_a = \frac{M_a \cdot n}{9550}$$

- F = force (N)
- P = thread pitch (mm)
- S_i = safety factor 1, 2 ... 2
- M_n = no-load torque (Nm)
- n = rpm of screw (min⁻¹)
- M_a = driving torque (Nm)
- μ = screw efficiency
- P_a = motor power (KW)

Efficiency of lead screws:

- All ballscrew 0,900
- Tr 18x4 0,399
- Tr 18x8 0,565
- Tr 24x5 0,384
- Tr 24x10 0,550
- Tr 32x6 0,360
- Tr 32x12 0,524

Deflection:

$$f = \frac{F \cdot L^3}{E \cdot I \cdot 192}$$

- f = deflection (mm)
- F = load (N)
- L = free length (mm)
- E = elastic modulus 70000 (N/mm²)
- I = second moment of area (mm⁴)

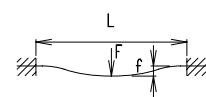

For the diagram for critical speeds of lead screws refer to chapter 4.2



Linear system QST/K 60, 80, 100

Dimensions (mm)

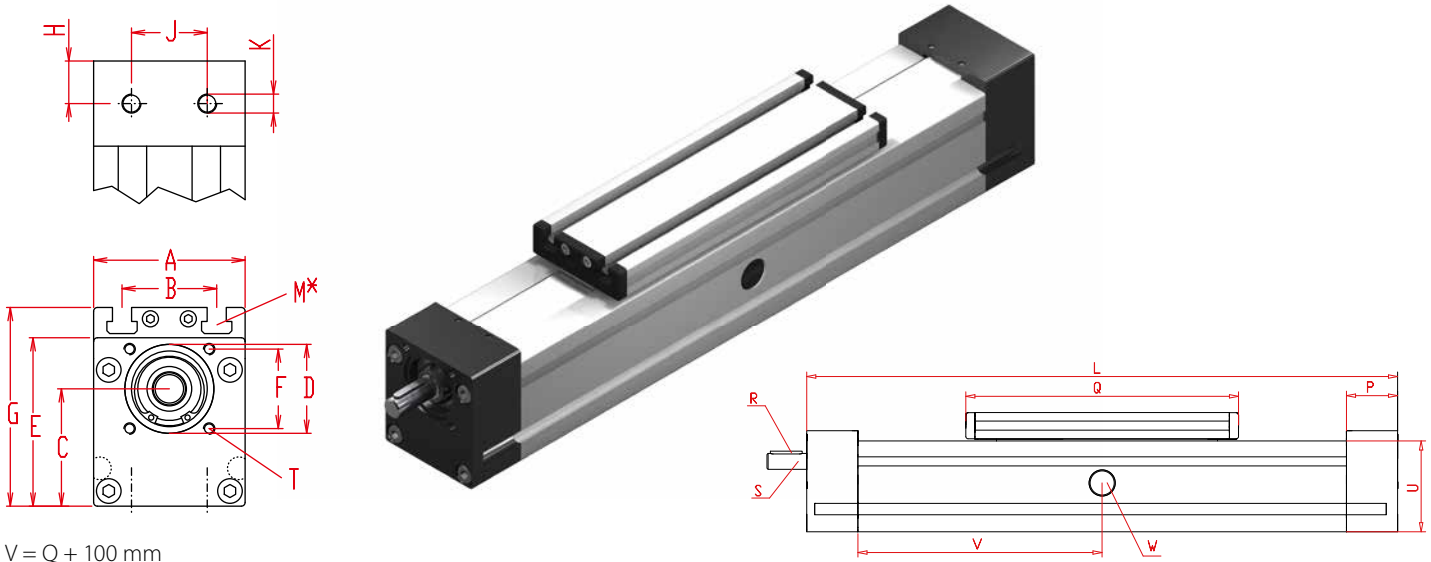

$V = Q + 100 \text{ mm}$

W = servicing position

*For slide nuts refer to chapter 2.2 page 2

Increasing the carriage length will increase the basic length by the same amount.

Size □	Basic length L	A	B	C	D -0,05	E	F □	G	H	J	K	M for	P	Q	Shaft		T for	U	Basic weight	Weight per 100 mm
															R Key	S Ø h6 x length				
QST/K 60	270	60	36	45	37	67	32	79	19	18	M6	M6	38	188	3x3x25	10 x 27	M5	60	4,1 kg	0,5 kg
QST/K 80	350	80	50	62	47	89	42	106	22,5	40	M10	M8	45	250	5x5x28	14 x 35	M6	80	7,5 kg	0,9 kg
QST/K 100	410	100	66	75	68	112	60	129	28,5	50	M10	M10	57	288	6x6x40	22 x 45	M8	100	14,8 kg	1,3 kg

K Spindle:
(T) Trapezoidal thread (K) Ballscrew

1 Selection of screw:
(1) right hand (Standard) (2) left hand (Ballscrew by inquiry)

0 Choice of carriage:

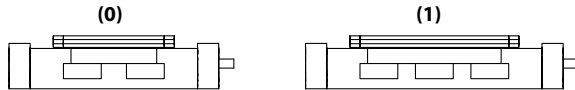

Size	Version 1	
	Q	L
60	255	350
80	336	436
100	383	510

0 Drive version:
(0) one shaft (locating bearing side) (1) one shaft (non-locating bearing side) (2) shaft on both sides

0 Selection of screw:

Size	Standard		Multistart screw		
	Trapezoidal thread		Ballscrew		
60	(0) Tr 18x4	(1) Tr 18x8	(0) Kg 16x5	(1) Kg 16x10	(2) Kg 16x16
80	(0) Tr 24x5	(1) Tr 24x10	(0) Kg 25x5	(1) Kg 20x20	(2) Kg 25x10 (3) Kg 25x25***
100	(0) Tr 32x6	(1) Tr 32x12	(0) Kg 32x5	(1) Kg 32x10	(2) Kg 32x32* (3) Kg 32x20**

* = Basic and carriage length (L and Q) increase over 47 mm
 ** = Basic and carriage length (L and Q) increase over 11 mm
 *** = Basic and carriage length (L and Q) increase over 42 mm

0 Choice of guide body profile:
(0) Standard (1) corrosion-protected screws

0 Ballscrew pitch accuracy:
(0) 0,05 mm / 300 mm (Standard) (2) 0,025 mm / 300 mm

0 End play of ball nut:
(0) 0,04 mm (Standard) (1) < 0,02 mm (2) 2% apply prestress

QS K 80 1 0 0 0 0 0 0 1500

Basic length + stroke = total length

For additional accessories refer to chapter 2.2

Sample ordering code:

QSK80, ballscrew right hand thread, standard carriage, one shaft (locating bearing side), spindle 25x5, 1150 mm stroke.



en 21.06.741.B

Our policy is one of continued research and development. We therefore reserve the right to amend, without notice, the specifications given in this document. (2023-9491) © 2023 Bahr Modultechnik GmbH

Linear system QST/K 60, 80, 100

SPINDLE DRIVEN RIGHT-HAND | LEFT-HAND | DIVIDED SPINDLE

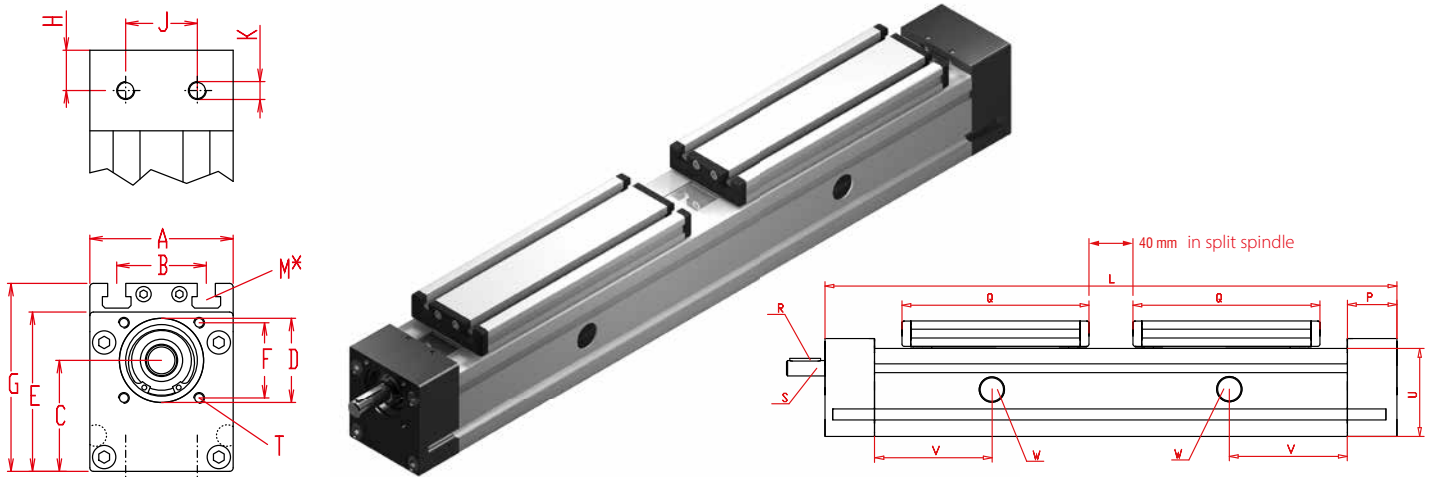

*For slide nuts refer to chapter 2.2 page 2

Increasing the carriage length will increase the basic length by the same amount.

Size □	Basic length L selection of screw		A	B	C	D -0,05	E	F □	G	H	J	K	M for	P	Q	Shaft		T for	U	Basic weight	Weight per 100 mm
	3	4														R Key	S Ø h6 x length				
QST/K 60	460	500	60	36	45	37	67	32	79	19	18	M6	M6	38	188	3x3x25	10 x 27	M5	60	5,4 kg	0,5 kg
QST/K 80	600	640	80	50	62	47	89	42	106	22,5	40	M10	M8	45	250	5x5x28	14 x 35	M6	80	9,8 kg	0,9 kg
QST/K 100	700	740	100	66	75	68	112	60	129	28,5	50	M10	M10	57	288	6x6x40	22 x 45	M8	100	18,6 kg	1,3 kg

K Spindle:

(T) Trapezoidal thread (K) Ballscrew

V = Q + 100 mm
W = servicing position

3 Selection of screw:
(3) right - left hand (4) divided spindle

0 Choice of carriage:

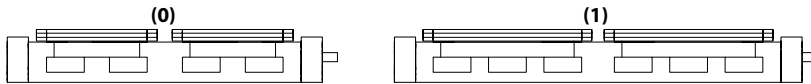

Size	Q	Carriage version 1	
		Basic length L selection of spindle	
		3	4
60	255	590	630
80	336	770	810
100	383	890	930

0 Drive version:
(0) shaft right hand thread (1) shaft left hand thread (2) shaft on both sides

Selection of screw:	Size	Standard	Multistart screw
Ballscrew right hand	60	(0) 16x5	(1) 16x10* (2) 16x16*
	80	(0) 25x5	(1) 20x20* (2) 25x10*
	100	(0) 32x5	(1) 32x10* (2) 32x32**
Ballscrew left hand	auf Anfrage		
Trapezoidal right hand thread	60	(0) 18x4	(1) 18x8
	80	(0) 24x5	(1) 24x10
	100	(0) 32x6	(1) 32x12
Trapezoidal left hand thread	60	(0) 18x4	(1) 18x8
	80	(0) 24x5	(1) 24x10
	100	(0) 32x6	(1) 32x12

* = only for selection of divided spindle
** = only for selection of divided spindle, Basic and carriage length (L and Q) increase over 94 mm

0 Choice of guide body profile:
(0) Standard (1) corrosion-protected screws
(4) expanded corrosion-protected version (depending on the availability of components)

0 Ballscrew pitch accuracy:
(0) 0,05 mm / 300 mm (Standard) (2) 0,025 mm / 300 mm

0 End play of ball nut:
(0) 0,04 mm (Standard) (1) < 0,02 mm (2) 2% apply prestress

QS K 80 3 0 0 0 0 0 1500 — Basic length + stroke = total length

Sample ordering code:

QSK80, ballscrew right - left hand thread, standard carriage, shaft on right hand thread, spindle 25x5, 860 mm stroke.