

# Smart Function Kit

for pressing and joining applications

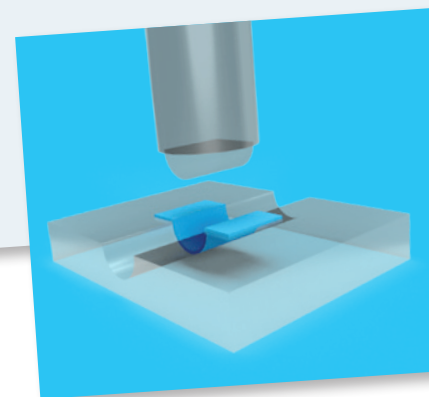

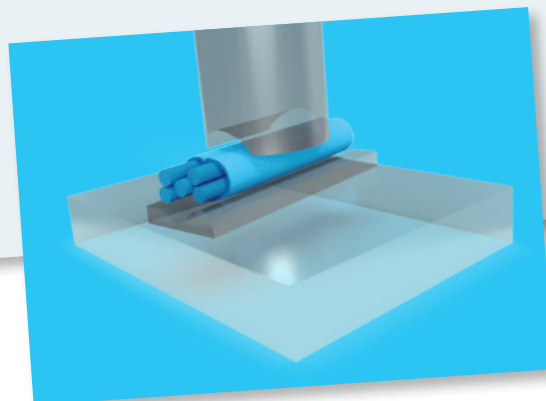
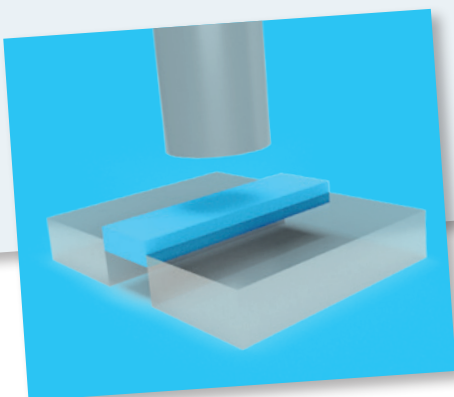
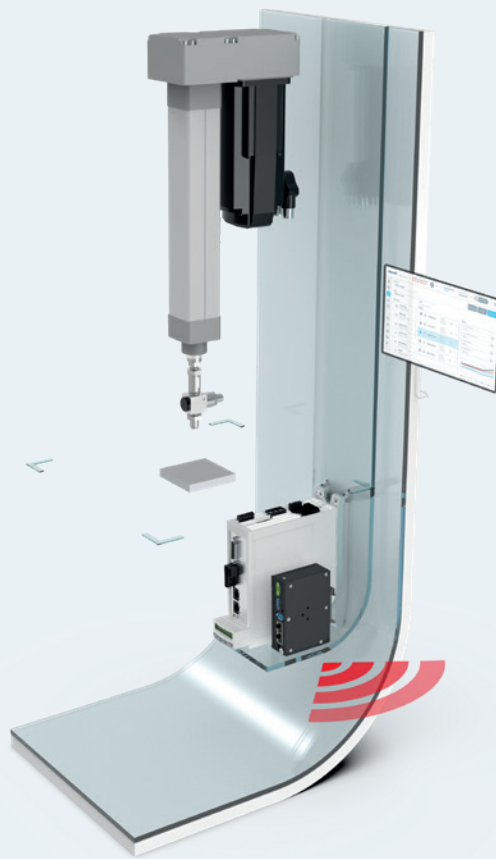

# Contents

<b>Product description</b>	<b>4</b>
Hardware	5
Software	6
<b>Technical data</b>	<b>8</b>
General information	8
Hardware	8
Electromechanical cylinder EMC	8
IndraDyn S - MS2N servo motors	12
HCS01 drive controller	14
HSZ01 safety zone module	15
PR21 industrial PC	16
Force sensor	18
Accessories	20
Software	21
General information	21
Dashboard	22
Sequence creation	22
Process and data	23
Reference curves and curve evaluation	23
Interfaces	24
<b>Configuration and CAD data</b>	<b>25</b>
<b>Ordering code</b>	<b>26</b>
<b>Additional documentation</b>	<b>27</b>

## Product description

The Smart Function Kit mechatronic subsystem is suitable for numerous pressing and joining applications.

- ▶ Observe the safety instructions in the manual R320103194.

The web-based software allows for both easy creation of a sequence by means of drag & drop of sequential modules and for the recording of the force-position curve and its subsequent evaluation (OK/NOK) by envelopes, windows and limit values.

The Smart Function Kit is thus an ideal basis for system integrators and end users and can be used as a stand-alone solution or incorporated into higher-level systems via fieldbus and/or OPC-UA.

- ▶ System kit for force range of up to 70 kN for assembly and joining processes, forming technology and test applications
- ▶ Pre-selected kits consisting of cylinder mechanics, drive controllers with integrated control and web-based operating software for easy and quick creation and evaluation of process sequences
- ▶ Easy commissioning using the pre-installed software and automatic drive parameterization
- ▶ Open interfaces for connection to higher-level controllers and data exchange via OPC-UA or the ReST API
- ▶ Optimum price/performance ratio

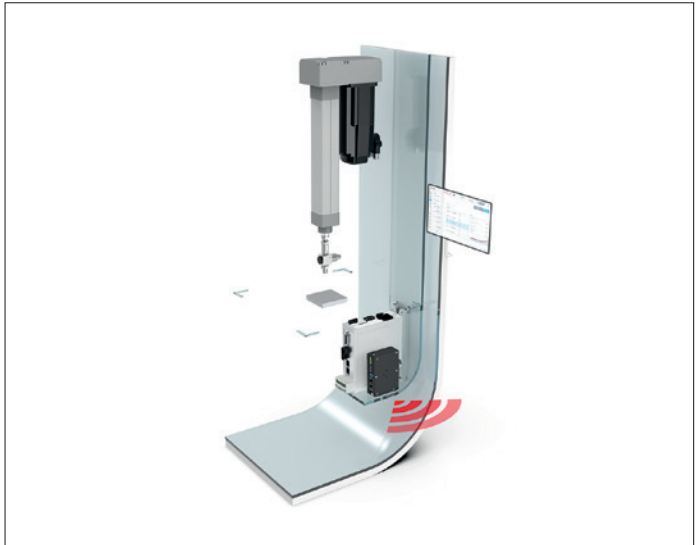

### Areas of application

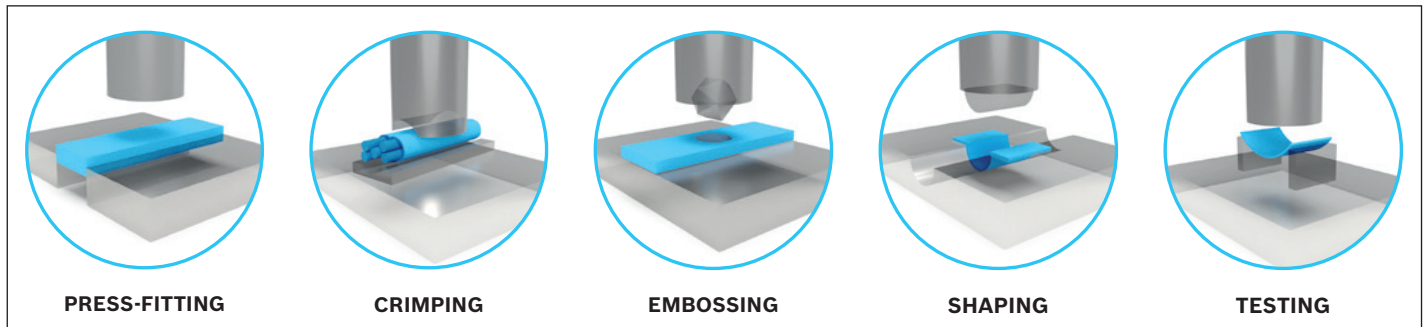

### Notes

- ▶ The SFK software does not require any programming knowledge. Only communication with higher-level control systems requires corresponding knowledge (definition of data transfer and bus interfaces as well as digital inputs and outputs). Suitable fieldbus sample projects are provided in the SFK software.
- ▶ Process data can be displayed live in the HMI. After the end of the program, they are available for further processing in JSON format.

Hardware

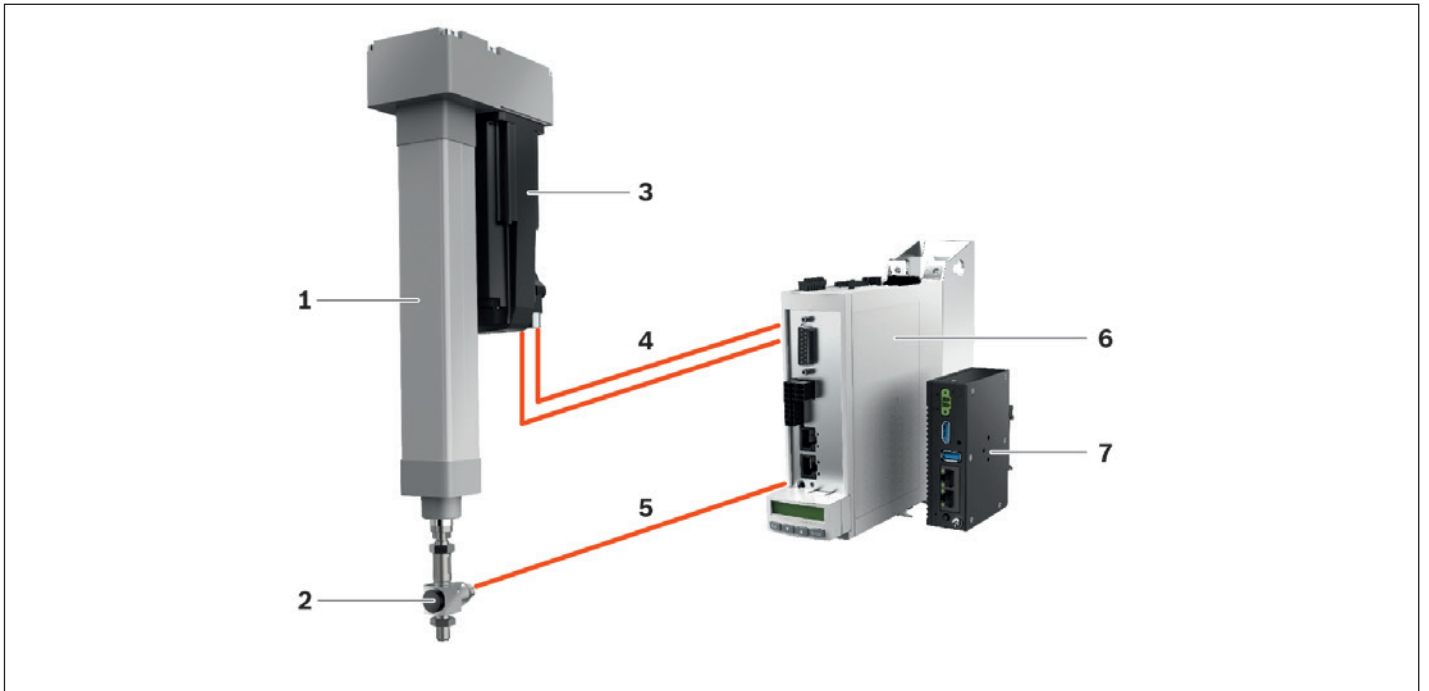

- 1 Electromechanical cylinder EMC** with freely configurable stroke up to 400 mm (longer stroke ranges upon request). Parallel or axial motor attachment
- 2 Force sensor:** DMS technology for cost-effective and robust force measurement
- 3 MS2N servo motor:** with absolute encoder and holding brake
- 4 Motor cable**
- 5 Sensor cable**
- 6 IndraDrive HCS01 drive controller** with integrated PLC IndraMotion MLD and safety function STO or Safe Motion
- 7 Industrial PC PR21** with integrated web server for providing the web-based operating software, with Linux operating system

## Software

Thanks to the modern, intuitive web HMI with modular drag-and-drop process configuration, the software is ready for immediate use, with no previous knowledge required. The straightforward process for the visual generation of all required evaluation and analysis elements is practically self-explanatory.

### Commissioning with auto configuration

- ▶ Preinstalled software
- ▶ Wizard for easy, fast commissioning
- ▶ Auto parameterization of the drive controller
- ▶ Support for commissioning with reference run and jog mode

### Simple programming and operation

- ▶ Modular process configuration with drag and drop
- ▶ Logic check of input data
- ▶ Process optimization supported by a control bar with current process values
- ▶ Simple visual definition of evaluation and analysis elements
- ▶ Visualization of process and status information in the dashboard
- ▶ Fieldbus sample projects for the easy integration into higher-level control systems

### Analysis and diagnosis via dashboard and logbook

- ▶ Live display of the sequence and the force-position curves
- ▶ Visualization of the process result (OK/NOK)
- ▶ Storing of process data for quality assurance in internal database
- ▶ Process history with filter and export function (export in JSON format)
- ▶ Diagnostic functions: System parameters as well as status reports and statistics
- ▶ Logbook with plain text error messages integrated in the software
- ▶ Data access via ReST programming interface

### Dashboard

The dashboard provides a compact overview of the system and production status. For this purpose, the four tiles contain information on production statistics, quality evaluation of the parts produced last, on the current program progress and the current process values.

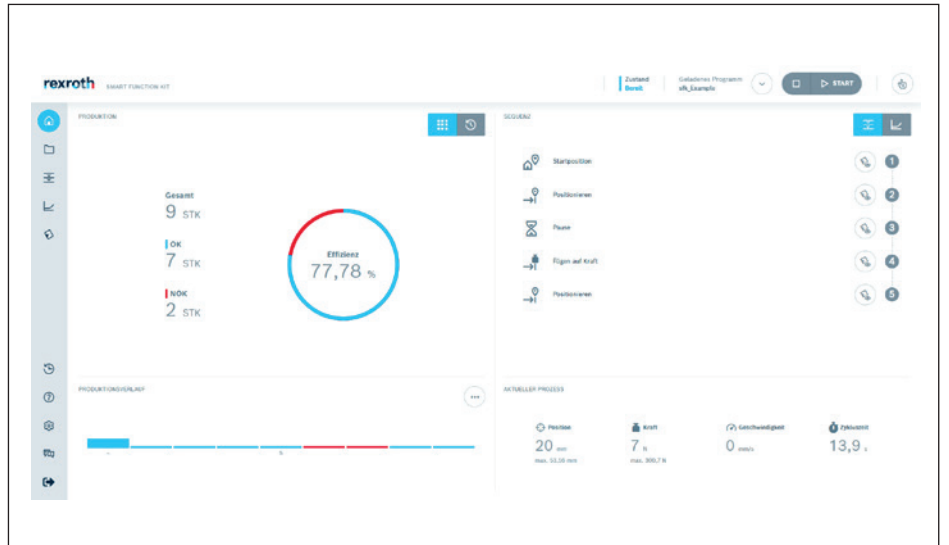

### Program creation

The process is created by dragging & dropping sequential modules from the library. The selected modules can afterwards be individually parameterized.

For quick and easy process creation, the control bar can be displayed on the right side of any screen. It allows manual traversing, taring of the force sensor and shows current values for position, force and velocity.

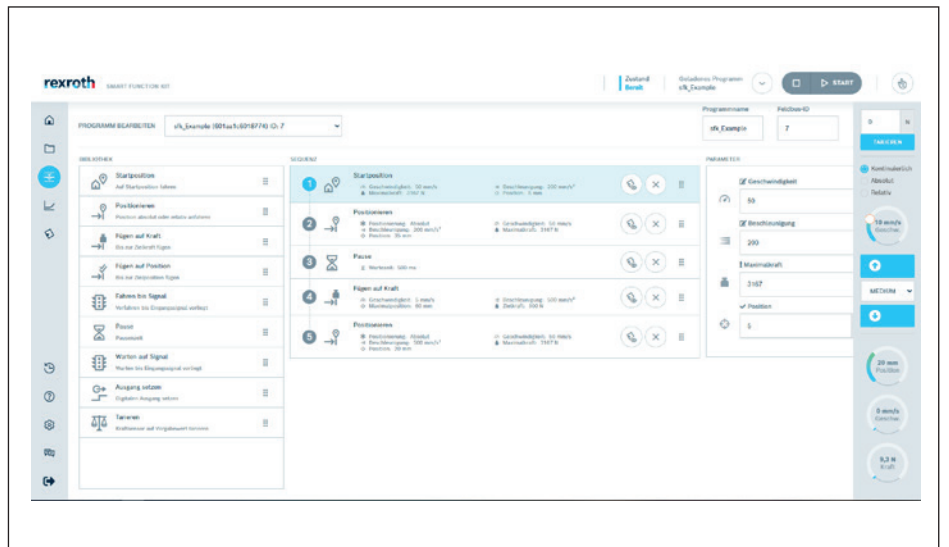

### Evaluation elements

In this area, you can individually define evaluation elements for every program in a graphical form. The elements are used for the automatic quality assessment and by means of their evaluation, the system determines whether a produced part is OK or NOK.

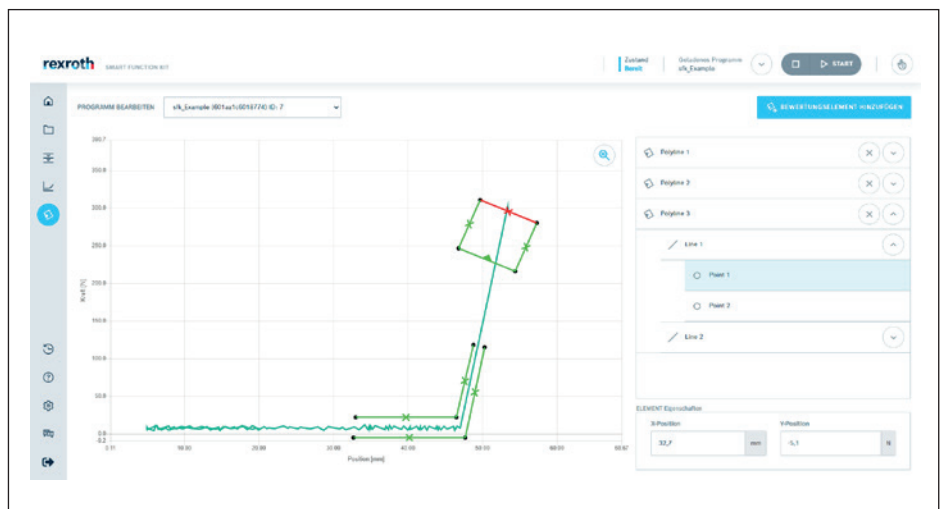

# Technical data

## General information

Smart Function Kit size		002	004	007	012	019	030	045	070
<b>Travel path</b> <sup>1)</sup>	mm	35 ... 400	40 ... 400	65 ... 400	80 ... 400	70 ... 400	90 ... 400	110 ... 400	130 ... 400
<b>Nominal force</b>	kN	2	4	7	12	19	30	45	70
<b>Maximum force</b>	kN	3	6	10	15	20	40	47	72
<b>Max. speed</b> <sup>1)</sup>	m/s	0.38	0.32	0.55	0.5	0.37	0.5	0.32	0.26 <sup>2)</sup> / 0.22 <sup>3)</sup>
<b>Repeatability</b>	mm	up to ± 0.01							

<sup>1)</sup> Higher values possible on request

<sup>2)</sup> Axial motor attachment

<sup>3)</sup> Parallel motor attachment

## Hardware

### Electromechanical cylinder EMC

Smart Function Kit / size		002	004	007	012	019	030	045	070
<b>EMC size</b>		040-NN-2	050-NN-2	063-NN-2	080-NN-2	100-NN-2	100-XC-2	130-HP	160-HP
<b>Screw lead</b>	mm	5	5	10	10	10	10	5	5
<b>Service life (on the basis of an internally defined reference cycle)</b>		> 10 million cycles							
<b>Relubrication interval in spindle revolutions</b>	Million	50	50	50	50	50	10	16	8

#### Length calculation:

Overall length of EMC for motor attachment with flange and coupling =  $L_{zs} + S_{max} + L_{ad} + L_f + L_m$

Overall length of EMC for motor attachment with belt side drive =  $L_{zs} + S_{max} + L_{ad} + G$

(for  $L_f$ ,  $L_m$  and  $G$ , see following page)



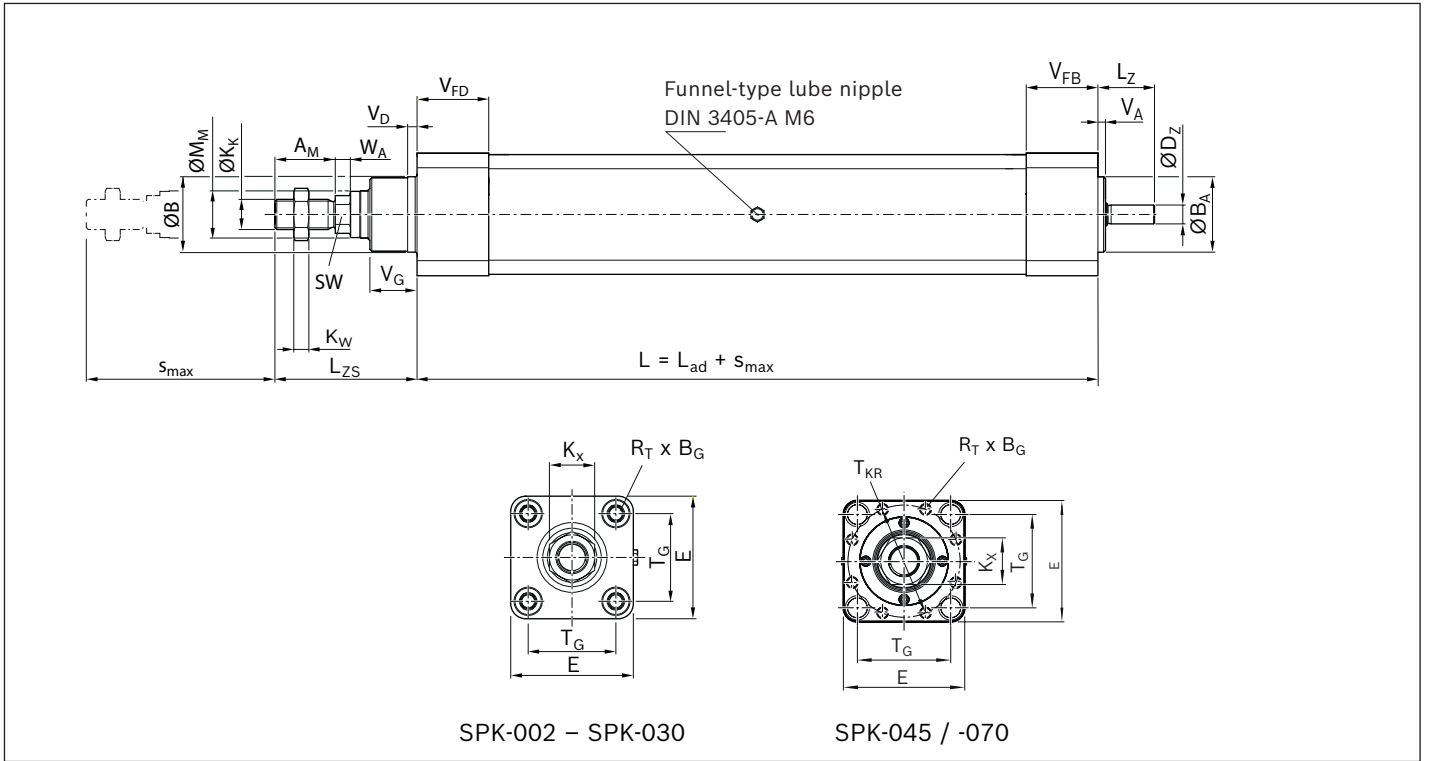

EMC / SPK	BASA d <sub>0</sub> x P	Dimensions (mm)								
		A <sub>M</sub> -0.1	B <sub>d11</sub> / B <sub>A</sub> h7	D <sup>Z</sup> h7	E ±0.1	K <sub>K</sub>	K <sub>W</sub>	K <sub>X</sub>	L <sub>ZS</sub>	
040 / 002	16 x 5	24	35	8	53	M12 x 1.25	7	19	61.50	
050 / 004	20 x 5	32	40	10	65	M16 x 1.5	8	24	76.75	
063 / 007	25 x 10	32	45	15	75	M16 x 1.5	8	24	76.50	
080 / 012	32 x 10	40	55	18	95	M20 x 1.5	10	30	94.50	
100 / 019	40 x 10	40	65	25	115	M20 x 1.5	10	30	99.25	
100XC / 030	50 x 10	72	75	32	115	M36 x 2	18	55	144.00	
130-HP / 045	39 x 5	71	ØB: 95; ØB <sub>A</sub> : 80	35	130	M33 x 2	26	50	155.00	
160-HP / 070	45 x 5 <sup>1)</sup> / 45 x 10 <sup>2)</sup>	89	ØB: 106; ØB <sub>A</sub> : 93	40	160	M42 x 2	34	65	176.00	

EMC / SPK	Dimensions (mm)															
	L <sub>ad</sub>	L <sub>Z</sub>	M <sub>M</sub> f8	R <sub>T</sub>	B <sub>G</sub>	ØT <sub>KR</sub>	R <sub>L</sub>	SW	T <sub>G</sub>	V <sub>A</sub> ±0.1	V <sub>D</sub>	V <sub>FB</sub>	V <sub>FD</sub>	V <sub>G</sub> ±0.1	W <sub>A</sub>	
040 / 002	134	25	20	M6	18		4	13	38.0	4	5	33	30	20	6	
050 / 004	142	30	25	M8	18		5	17	46.5			38	38	25	8	
063 / 007	148	35	30	M8	18		5	17	56.5			40	38	25	8	
080 / 012	163	46	38	M10	22		6	22	72.0			44	45	33	10	
100 / 019	171	57	50	M10	22		6	22	89.0			54	45	38	10	
100XC / 030	316	62	60	M12	28		7	36	89.0			121	62	38	18	
130-HP / 045	364	78	60	M12 (8x)	26	120	-	50	100.0			-	117.5	95.5	30	22
160-HP / 070	418.5	82	70	M14 (8x)	29	145	-	60	125.0	-	135	105.5	30	25		

1) Axial motor attachment  
2) Parallel motor attachment

## Motor attachment

Axial

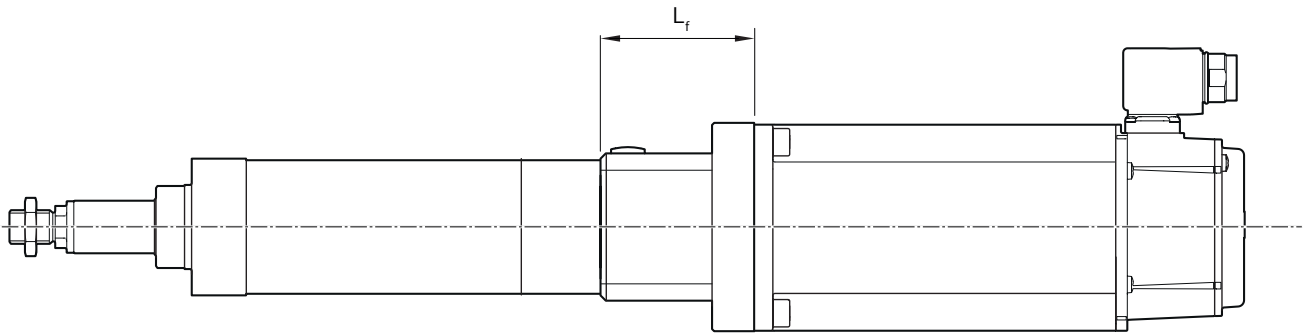

Parallel

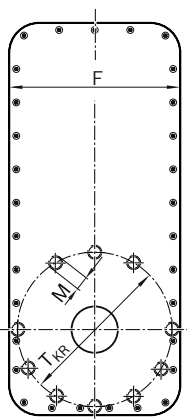

SPK-045 / -070

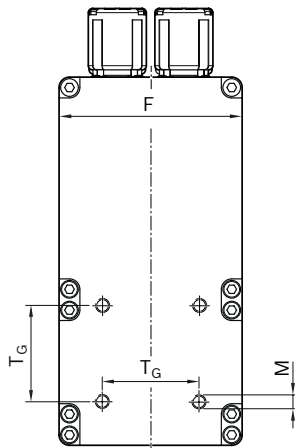

SPK-002 - SPK-030

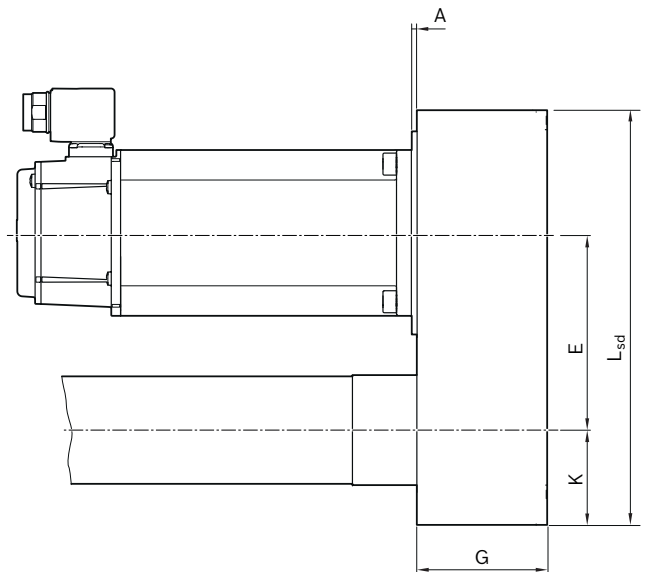

EMC SPK	For motor	i	Dimensions (mm)										
			A	E	F	G	K	L <sub>f</sub>	L <sub>sd</sub>	M	T <sub>G</sub>	ØT <sub>KR</sub>	Mt <sup>1)</sup>
<b>040 002</b>	MS2N04-B	1	–	82.2	88	55.5	44.0	61	177	M6	38.0	–	16.0
<b>050 004</b>	MS2N04-C	1	–	82.2	88	55.5	44.0	73	177	M8	46.5	–	16.0
<b>063 007</b>	MS2N05-D	1	3.0	117.2	116	77.0	56.0	95	245	M8	56.5	–	16.0
<b>080 012</b>	MS2N06-D	2	2.5	117.2	160	102.0	77.0	–	324	M10	72.0	–	16.0
	MS2N06-E	1	–	–	–	–	–	100	–	–	–	–	–
<b>100 019</b>	MS2N06-E	2	2.5	151.4	160	102.0	77.0	–	324	M10	89.0	–	16.0
	MS2N07-D	1	–	–	–	–	–	119	–	–	–	–	–
<b>100XC 030</b>	MS2N07-E	1.5	3.0	175.6	197	113.5	89.0	–	375	M12/M16	89.0/140.0	–	24.0
	MS2N10-D	1	–	–	–	–	–	145	–	–	–	–	–
<b>130-HP 045</b>	MS2N07-D	1.5	–	211.0	200	91.0	100.0	–	458	M10 (10x)	–	178	25.0
		1	–	–	–	–	–	154	–	–	–	–	–
<b>160-HP 070</b>	MS2N10-D	1.5	10.0	248.0	255	96.0	127.5	–	504	M12 (10x)	–	228	26.0
		1	–	–	–	–	–	188	–	–	–	–	–

<sup>1)</sup> Do not exceed max. permissible screw-in depth for "M" threads

Further information about motors ➡ Chapter "IndraDyn S - MS2N servo motors"

## IndraDyn S - MS2N servo motors

<b>Smart Function Kit size</b>	<b>002</b>	<b>004</b>	<b>007</b>	<b>012</b>	<b>019</b>	<b>030</b>	
<b>Axial motor attachment</b>	MS2N04-B0BTN	MS2N04-C0BTN	MS2N05-D0BRN	MS2N06-E0BRN	MS2N07-D0BRN	MS2N10-D0BHA	
<b>Parallel motor attachment</b>	MS2N04-B0BTN	MS2N04-C0BTN	MS2N05-D0BRN	MS2N06-D0BRN	MS2N06-E0BRN	MS2N07-E1BNN	
<b>Encoder type</b>	Absolute value encoder						
<b>Brake</b>	With holding brake						

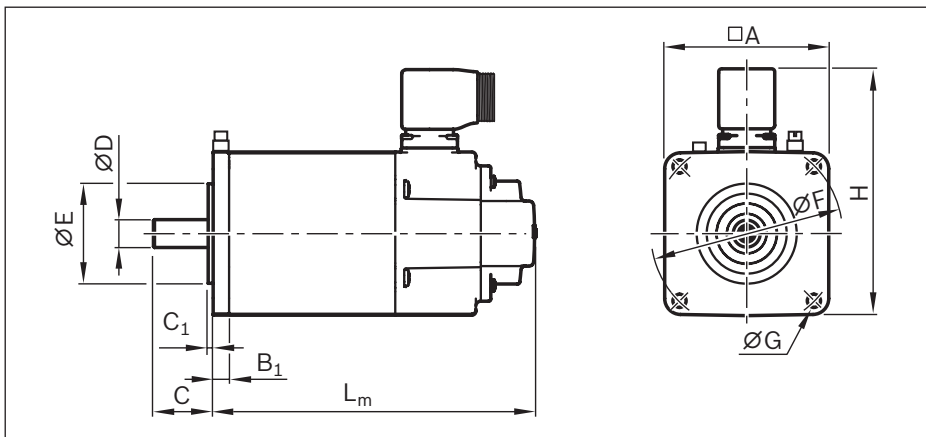

Motor representation, schematic

Motor code	Dimensions (mm)										
	□ A	B <sub>1</sub>	C	C <sub>1</sub>	Ø D <sub>k6</sub>	Ø E <sub>j6</sub>	Ø F	Ø G	H	L <sub>m</sub>	
MS2N04-B0BTN	82	8	30	2.5	14	50	95	6.6	108	194.5	
MS2N04-C0BTN	82	8	30	2.5	14	50	95	6.6	108	226.5	
MS2N05-D0BRN	98	9	40	3.0	19	95	115	9.0	124	290.0	
MS2N06-D0BRN	116	14	50	3.0	24	95	130	9.0	156	261.0	
MS2N06-E0BRN	116	14	50	3.0	24	95	130	9.0	156	301.0	
MS2N07-D0BHA	140	18	58	4.0	32	130	165	11.0	203	438.0	
MS2N07-D0BRN	140	18	58	4.0	32	130	165	11.0	180	317.0	
MS2N07-E1BNN	140	18	58	4.0	32	130	165	11.0	180	375.0	
MS2N10-D0BHA	196	20	80	4.0	38	180	215	14.0	274	454.0	

	045	070
	MS2N07-D0BHA	MS2N10-D0BHA
	MS2N07-D0BHA	MS2N10-D0BHA

### Version

- ▶ With holding brake
- ▶ Plain shaft without shaft seal ring
- ▶ Advanced multiturn encoder (CM) with AcuroLink interface
- ▶ IP64 protection class
- ▶ Special ground connection terminal near motor flange (used as needed)

	Motor data								Motor connection (cable)	Type code
	$n_{\max}$ (rpm)	$M_0$ (Nm)	$M_{\max}$ (Nm)	$M_{br}$ (Nm)	$J_m$ (kgm <sup>2</sup> )	$J_{br}$ (kgm <sup>2</sup> )	$m_m$ (kg)	$m_{br}$ (kg)		
	6,000	1.75	5.9	5.0	0.00007	0.000040	2.7	0.7	1	MS2N04-B0BTN-CMSH1-NNNNE-NN
	6,000	2.80	12.0	5.0	0.00011	0.000050	3.7	0.7	1	MS2N04-C0BTN-CMSH1-NNNNE-NN
	6,000	7.90	31.3	10.0	0.00040	0.000110	7.3	1.1	1	MS2N05-D0BRN-CMSH1-NNNNE-NN
	6,000	9.70	32.0	15.0	0.00065	0.000140	9.0	1.5	1	MS2N06-D0BRN-CMSH2-NNNNE-NN
	6,000	13.0	49.0	15.0	0.00089	0.000140	11.5	1.5	1	MS2N06-E0BRN-CMSH2-NNNNE-NN
	4,000	35.5	73.2	36.0	0.00210	0.000410	20.0	2.5	2	MS2N07-D0BHA-CMVH2-NNNNE-NN
	6,000	22.0	73.2	36.0	0.00210	0.000410	17.5	2.5	1	MS2N07-D0BRN-CMVH2-NNNNE-NN
	6,000	25.8	128.5	36.0	0.00752	0.000410	23.0	3.0	1	MS2N07-E1BNN-CMVH2-NNNNE-NN
	4,000	82.4	142.0	53.0	0.00810	0.001470	35.0	5.0	2	MS2N10-D0BHA-CMVH2-NNNNE-NN

## HCS01 drive controller (with integrated control system)

Smart Function Kit / size		002 / 004		007	012	019	030	045	070
Size	Axial motor attachment	HCS01.1E-W0008	HCS01.1E-W0013	HCS01.1E-W0028		HCS01.1E-W0054			
	Parallel motor attachment			HCS01.1E-W0028		HCS01.1E-W0054			
Mains connection voltage	1 x AC	–	110 ... 230 V	–					
	3 x AC	200 ... 500 V	110 ... 230 V	200 ... 500 V					
Maximum current (output-side)	Axial motor attachment	A	8	13	28		54		
	Parallel motor attachment	A			28		54		
Power inlet Continuous current $I_{LN}$ at $U_{LN\_rated}$ and $P_{DC\_cont}$	Single-phase, without mains choke		A	–	8.3 <sup>1)</sup>		–		
	Three-phase, without mains choke	Axial motor attachment	A	2.5 A <sup>1)</sup>	4.5 <sup>1)</sup>	8 <sup>1)</sup>		25 <sup>1)</sup>	
		Parallel motor attachment	A			8 <sup>1)</sup>		25 <sup>1)</sup>	
				Profinet, Ethernet/IP, EtherCAT, Sercos III					
Field bus interface									
Protection class		IP20							

<sup>1)</sup> The actual phase current on the supply side highly depends on the application (cycle, load case etc.) and must be calculated.

### Safety functions

Safety option	Safety function acc. to EN 61800-5-2		Safety level <sup>2)</sup> up to
L3 - STO	Safe standstill	Safe torque off (STO)	Category 4, PL e, SIL 3
S4 - Safe Motion	Safe standstill	Safe torque off (STO)	
		Safe brake control (SBC)	
		Safe operating stop (SOS)	
		Category 3, PL d, SIL 2	
	Safe shutdown	Safe stop 1 – time controlled (SS1-t)	Category 4, PL e, SIL 3
		Safe stop 1 – ramp monitored (SS1-r)	Category 3, PL d, SIL 2
		Safe stop 2 – ramp monitored (SS2-r)	
		Safe monitored deceleration (SMD) <sup>1)</sup>	
Safe motion	Safe limited speed (SLS)		
	Safe maximum speed (SMS) <sup>1)</sup>		

<sup>1)</sup> Not defined in EN 61800-5-2

<sup>2)</sup> Acc. to EN 13849-1 and EN 62061

**Note:** A cyclic test of the brake in accordance with DIN EN ISO 13849-1, category 2 is currently not supported

	HCS01.1E-W0008-A-03	HCS01.1E-W0013-A-02	HCS01.1E-W0028-A-03	HCS01.1E-W0054-A-03
Size	1	1	2	3
A mm	50	50	70	130
B <sub>1</sub> mm	215	215	268	268
B <sub>2</sub> mm	160	160	213	213
C <sub>1</sub> mm	220	220	220	220
C <sub>2</sub> mm	196	196	196	196
Mass kg	0.72	0.72	1.7	4.22

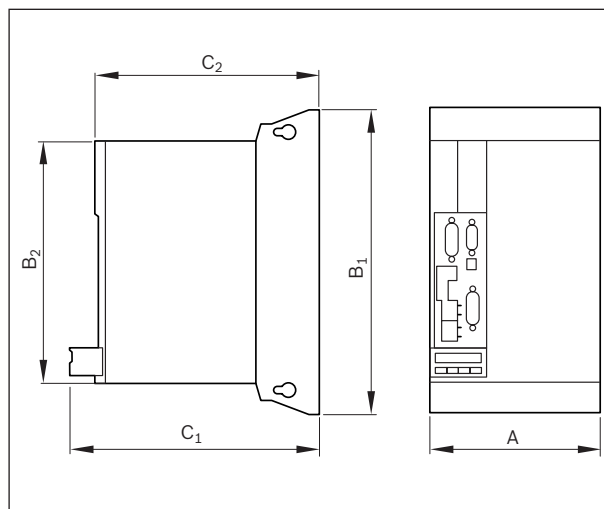

## HSZ01 safety zone module

In the drive controller option S4, the safety zone module HSZ01.1 is used in addition  
Also included in the scope of delivery: 2 x bus cable, 1 m length

<b>Designation</b>	<b>HSZ01.1-D08-D04-NNNN</b>		
<b>Protection class</b>	IP20		
<b>Conductive contamination</b>	Not permissible (They prevent conductive contamination, e.g. due to the installation of the devices in control cabinets of the protection class IP54 to IEC529.)		
<b>Permissible installation position</b>	Vertically in a control cabinet		
<b>Weight</b>	<b>m</b>	<b>kg</b>	0.65
<b>Minimum distance from the top of the device</b>	<b>d<sub>top</sub></b>	<b>mm</b>	40
<b>Minimum distance from the bottom of the device</b>	<b>d<sub>bot</sub></b>	<b>mm</b>	40
<b>Minimum distance from the side of the device</b>	<b>d<sub>hor</sub></b>	<b>mm</b>	-
<b>Permissible ambient temperature range</b>	<b>T<sub>a,work</sub></b>	<b>°C</b>	0 ... 55
<b>Permissible relative humidity</b>		<b>%</b>	5 ... 85
<b>Cooling type</b>	Natural convection		
<b>Voltage supply</b>			
<b>Input, control voltage <sup>1)</sup></b>	<b>U<sub>ext</sub></b>	<b>V</b>	19.2 ... 30
<b>Own consumption</b>	<b>P<sub>ext</sub></b>	<b>W</b>	0.5
<b>Output current <sup>2)</sup></b>	<b>I<sub>max</sub></b>	<b>A</b>	3.4

<sup>1)</sup> When selecting the control voltage, observe the requirements of the door lock

<sup>2)</sup> Total of all output currents at the outputs (excluding SDL\_Ch2)

**Note:** The Smart Function Kit is suitable for use of the S4 safety technology in connection with the HSZ01 safety zone module. Integration into a global safety system, e.g. using PROFIsafe, is possible on request.

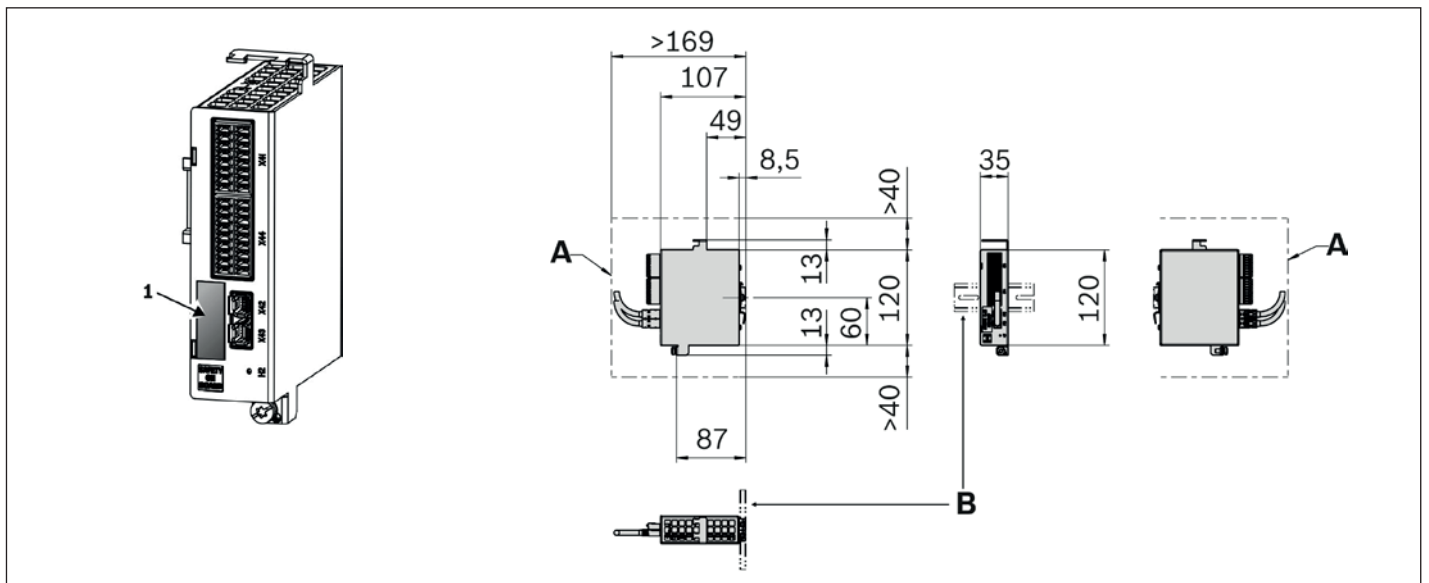

## PR21 industrial PC

<b>Operating system</b>	Linux Ubuntu Core
<b>CPU</b>	Intel Atom E3815; 1.46 GHz
<b>Storage</b>	4G DDR3L, 1066 MHz RAM
<b>Mass storage</b>	32 GB eMMC onboard
<b>Interfaces</b>	1 × USB 3.0 2 × Realtek RTL8111E GbE Ethernet 1 × HDMI video port
<b>RTC battery</b>	RTC battery button cell BR2032
<b>Assembly</b>	DIN rail mounting
<b>Input voltage range</b>	DC 24 V + 25%, -20%
<b>Power consumption</b>	Maximum 20 W
<b>Protection class</b>	IP20

<b>A<sub>1</sub></b>	<b>mm</b>	30
<b>B</b>	<b>mm</b>	100
<b>C<sub>1</sub></b>	<b>mm</b>	70
<b>C<sub>2</sub></b>	<b>mm</b>	6.5
<b>Mass</b>	<b>kg</b>	0.4

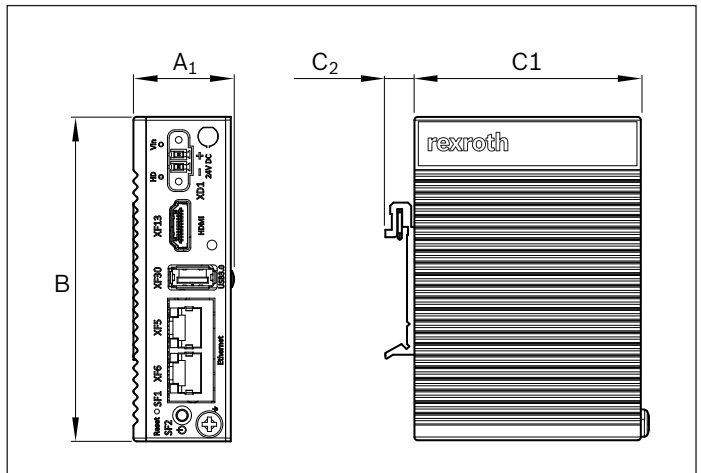





## Force sensor

### Features

- ▶ Corrosion-resistant stainless steel version
- ▶ High reproducibility
- ▶ Easy mounting directly at the EMC piston rod

### Note

- ▶ If the process requires joining to a specified force value, a force sensor is required as otherwise, no stable process result can be achieved.
- ▶ Calibration certificate included in delivery.

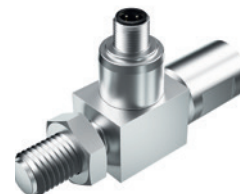

### Metrological specifications

Smart Function Kit / size	002	004	007	012	019	030	045	070	
Measurement technology	Strain gauge (DMS)								
Compressive force measuring range <sup>1)</sup>	kN	3	6	10	15	20	40	55	75
Traction force measuring range	kN	0.3	0.6	1					
Protection type		IP67							
Operating load (of the measuring range)	%	150							
Breaking load (of the measuring range)	%	300							
Non-linearity (of the measuring range)	%	± 0.3							
Relative creeping (of the measuring range)	%	0.1							
Hysteresis (of the measuring range)	%	0.1							
Temperature drift at zero point (of the measuring range per Kelvin)	%	0.02							
Temperature drift above measuring range (of the measuring range per Kelvin)	%	0.02							
Compensated temperature (min ... max)		-20 °C ... +80 °C							
Working temperature (min ... max)		-30 °C ... +80 °C							
Resolution		11 Bit							

<sup>1)</sup> Smaller measuring ranges on request

### Electrical specifications

Smart Function Kit / size	002	004	007	012	019	030	045	070	
Output signal (0kN)	0.909 V ± 0.01			0.625 V ± 0.01	0.476 V ± 0.01	0.244 V ± 0.01	0.179 V ± 0.01	0.132 V ± 0.01	
Output signal (measuring range)	0 ... +10 V								
Nominal rating	N/V	330	660	1100	1600	2100	4100	5600	7600
Power supply voltage		14 ... 30 V							
Current consumption		8 mA (24V)							
Bandwidth		1 kHz ± 0.2							
Connector		Plug M12 x 1 4-pin							

### Electrical connection

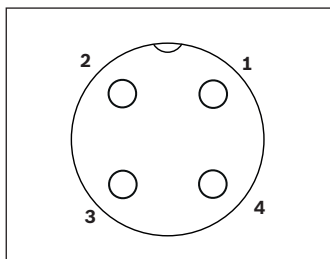

#### Force sensor

- 1 Supply (+)
- 2 -
- 3 GND
- 4 Output

#### Connection cable

- 1 brn
- 2 -
- 3 blu
- 4 blk

Connection cable length 15 m;  
with M12 connector with free cable ends

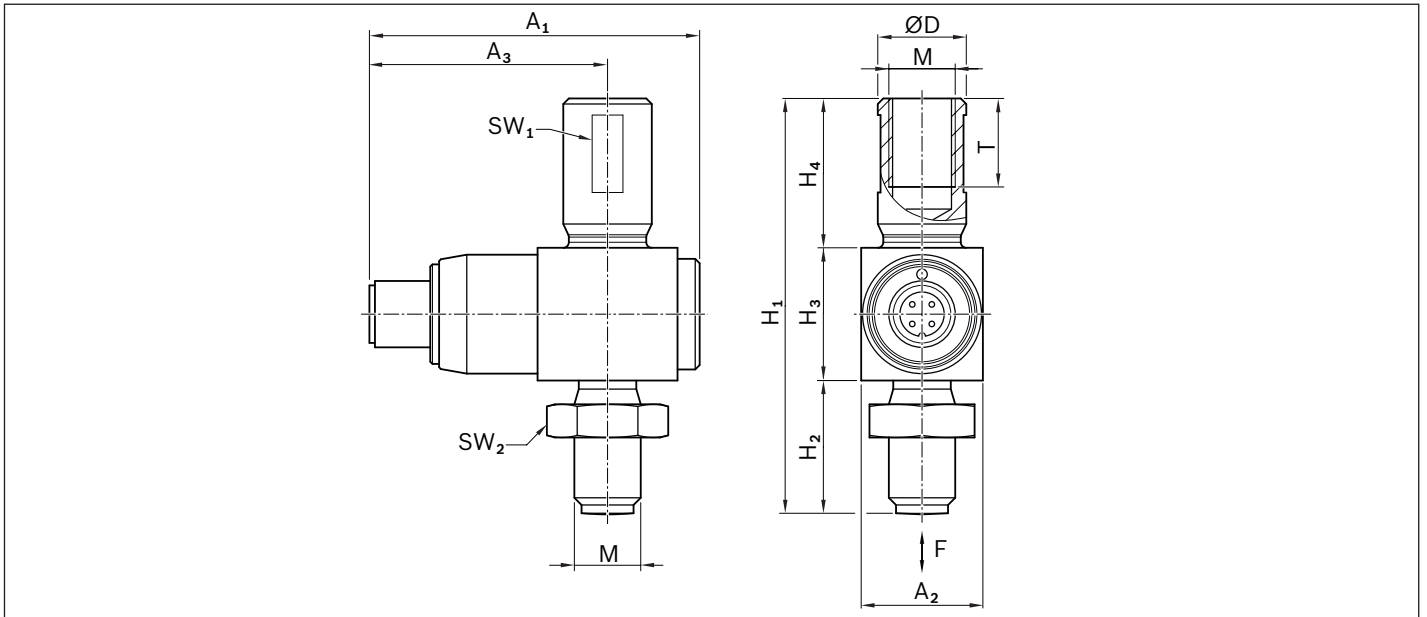

Smart Function Kit / size		002	004	007	012	019	030	045	070
A <sub>1</sub>	mm		69		71	74	82	83	98.5
A <sub>2</sub>	mm		25.3				35	37.5	50
A <sub>3</sub>	mm		56				57	58	66
ØD	mm	18	24.5		30		50	50	65
H <sub>1</sub>	mm	75	100		134		185	185	195
H <sub>2</sub>	mm	24	32		40		57	57	70
H <sub>3</sub>	mm	24	33		50			50	40
H <sub>4</sub>	mm	27	35		44		78	78	85
M		M12 x 1.25	M16 x 1.5		M20 x 1.5		M36 x 2	M33 x 2	M42 x 2
T	mm	16	23		29		49	49	59
SW <sub>1</sub>	mm	16	22		26		46	46	55
SW <sub>2</sub>	mm	19	24		30		55	50	65

### Ordering data

Smart Function Kit / size	Material number Force sensor
002	R156623001
004	R156633001
007	R156643001
012	R156653001
019	R156663001
030	R156673001
045	R156683001
070	R156693001



### Data connection cable

Model	M12, 4-pin, A-coded
Connection 1st side	Straight female connector
Connection 2nd side	Open cable ends
Cable length	15 m
Number of wires/wire cross-section	4 × 0.34 mm <sup>2</sup>
Shielding	With shielding
Operating voltage	30 V
Operating current per wire	4 A
External Ø	Less than 4.7 mm ± 5%
Drag chain values	10 million
Bending radius (moved)	10 × external Ø
Temperature range (stationary)	-40...+80 °C
Temperature range (moved)	-25...+80 °C
Protection class	IP67 in screwed condition
Cable color	Black
Approvals	UL, CSA, CE, UKCA

Connecting cable material number: **R901533653**





## Accessories

### Mounting elements

Flange mounting	Foot mounting
	

For further mounting elements please see catalog Electromechanical Cylinders R999000493

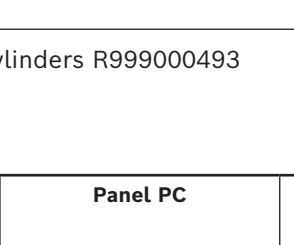
### Electrical accessories

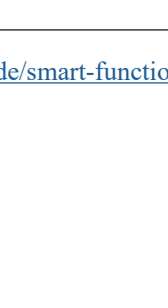
Uninterruptible power supply VAU	Mains filter NFE/NFD	Power supply unit VAP01	Panel PC WR21	Ethernet cable 5 m RKB
				

For accessories data and further accessories, please see: [www.boschrexroth.de/smart-function-kit](http://www.boschrexroth.de/smart-function-kit)

Software

**General information**

<b>Access to front end via</b>	Web browsers, such as Firefox, Chrome
<b>HMI device display formats</b>	>10 inch, software adapts automatically
<b>Languages in HMI</b>	German, English, Chinese
<b>Number of user levels</b>	Two: user, admin
<b>"User" permissions</b>	Select program, start program, view log file, change language
<b>"Admin" permissions</b>	Just as "User" and in addition machining programs, configuring evaluation elements, performing start-up, launching a reference run, accessing configuration parameters
<b>Availability of software updates</b>	Available for download on website
<b>Software license</b>	No additional license required for SFK software
<b>Front end hosting</b>	Hosting by PR21 industrial PC
<b>Connection between PR21 and HMI device</b>	Connection via network cable or wi-fi (no wi-fi router included)

## Dashboard

<b>Dashboard data</b>	Production statistics, evaluation of last produced parts, live sequence, live process data
<b>Production statistics data</b>	Number of OK parts, number of NOK parts and efficiency
<b>Time horizon production statistics</b>	Unlimited (as long as memory is available), statistical reset possible
<b>Live sequence display</b>	Program steps of the selected program with currently executed step or live curve.
<b>Data in live curve</b>	X-axis: Position or time Y-axis: Force
<b>Configurability of the live curve</b>	Display in force-position diagram or force-time diagram possible
<b>Process live data</b>	Position, force, velocity
<b>Additional cycle data</b>	Max. position, max. force, cycle time

## Sequence creation

<b>Programming scheme</b>	Programming via graphical modules which are arranged one after the other. A block corresponds to a sequence step which is filled with parameters.
<b>Available sequence modules</b>	Initial position, position, join to force (with position monitoring), force-controlled joining (with force and position monitoring), Join to position (with force monitoring), move to signal, delay, wait for signal, set output, tare, set variable, check force/position target window, Start data recording and End data recording.
<b>Data recording</b>	Sequence section in which data is recorded can be defined using the Start data recording and End data recording modules
<b>Adjustable parameters</b>	Depending on the sequence step, e.g. velocity, acceleration, target position, target force, maximum force, maximum position, ...
<b>Definition of parameter values</b>	In the front end or transfer from higher-level PLC using variables (max. 100 variables usable)
<b>Configurable termination criteria</b>	Exceeding maximum force or maximum position
<b>Handling of false entries</b>	Parameters are subject to a logic check that prevents serious incorrect inputs.
<b>Max. number of programs</b>	99
<b>Max. number of steps per sequence</b>	500
<b>Behavior between sequence steps</b>	Slurring of movement, no braking between steps (Exception: initial position).
<b>Relevance of sequence steps for evaluation</b>	Selectable during program creation whether program step for evaluation is taken into account or not.
<b>External interaction during program execution</b>	Interaction via digital (via HCS01) or virtual (via fieldbus) inputs and outputs.
<b>Number of digital inputs and outputs</b>	7 inputs (1 of which is pre-assigned for E-Stop), 1 output
<b>Number of virtual inputs and outputs</b>	16 inputs, 16 outputs
<b>Format of program export/import</b>	Export to / import from JSON file

## Process and data

<b>Monitoring options</b>	Force monitoring, position monitoring
<b>Control behavior</b>	Position control, force control
<b>Manual operations (jog mode)</b>	Continuous, absolute and relative process with individually adjustable speed
<b>Stop command options</b>	Via HMI, digital I/Os, fieldbus
<b>Error response</b>	Abort program, display of error message, if necessary prompt to clear error
<b>Program abort response time</b>	2 ms + braking time
<b>Live data evaluation</b>	Program abort when abort criteria are exceeded, or when the window defined in the "Check force/position target window" block is violated, no evaluation of trends etc.
<b>Max. data recording frequency</b>	500 Hz (one data point every 2 ms)
<b>Max. number of measuring points</b>	Total duration press cycle / 2 ms
<b>Max. duration press cycle</b>	15 minutes
<b>Process data archiving</b>	Storage of each press cycle in the internal database, ring buffer can be activated to limit the number of curves in the internal database to the defined capacity (oldest curves are automatically overwritten)
<b>Archived and exportable data</b>	Time stamp, evaluation (OK or NOK), max. position, max. force, cycle time, Serial number, program name, force/path curve with evaluation elements
<b>Filter function in press history</b>	Can be filtered by date, program name and evaluation
<b>Max. number of archived press cycles/curves</b>	Approx. 1 million (free space ~25 GB) or according to defined ring buffer capacity
<b>Format of curve export</b>	JSON
<b>Memory usage</b>	approx. 12.6 kb per second data recording for an average reference process

## Reference curves and curve evaluation

<b>Basis of evaluation</b>	Evaluation elements in conjunction with reference curve
<b>Available evaluation elements</b>	Limits, windows, envelope curves (points can be defined flexibly)
<b>Type of reference curve</b>	Force-position diagram
<b>Recommended maximum number of reference curves per program</b>	30
<b>Measurements</b>	Force, position (only actual values, no gradients)
<b>Max. number of points in envelope curve</b>	100
<b>Max. number of evaluation elements per program</b>	50
<b>Addition of evaluation element by</b>	Graphical drawing in web HMI
<b>Editability of an evaluation element after creation</b>	Graphically displaceable or by adjusting the x/y coordinates of the points
<b>Display evaluation result</b>	OK/NOK
<b>Display crosses with evaluation elements</b>	Visual representation in force-position curve, output in export file (JSON)
<b>Fault diagnostics for NOK result</b>	Output NOK, visual representation in force-position curve
<b>Response behavior in case of NOK result</b>	Output of the NOK result in the dashboard ➔ Evaluation elements are not a termination criterion during the cycle
<b>Evaluation/response to trends</b>	Trends cannot be evaluated within the SFK software
<b>Evaluation of individual evaluation elements</b>	Holistic evaluation of the force-position curve, no separate evaluation of individual evaluation elements
<b>Fieldbus evaluation results</b>	OK/NOK readable as status bit
<b>Evaluation elements via fieldbus</b>	Limits of the evaluation element window can be read out via variables
<b>Process data via fieldbus</b>	Maximum force in the window and position at maximum force can be read out via variables

## Interfaces

<b>Available interfaces:</b>	Fieldbus, REST API, OPC-UA, digital I/Os
<b>Supported field bus protocols</b>	SERCOS III, PROFINET, EtherCAT, EtherNet/IP
<b>Fieldbus commands</b>	Start program, set program active, position absolute, position relative, delete error, stop motion, reboot drive, tare force sensor, start reference run, set system variable, lock participant, set reference, read system variable (e.g. max. position, max. force and time of last cycle)
<b>Real-time data via fieldbus</b>	Active program number, live position, live speed, live force
<b>Fieldbus (0 or 1) status information</b>	Axis in reference, Program active, last pressing OK, last pressing NOK, sensor tared, press ready, error, warning, request possible, response available, notification available, SMES: Emergency stop active, SMST: Safe standstill active
<b>Trigger possibilities</b>	7 digital inputs (1 of which is pre-assigned for E-Stop), 1 digital output on the HCS01 drive controller; 16 bits each, which can be used as virtual input or output (via fieldbus)
<b>Traceability possibility</b>	Optional allocation of a serial number (max. 28 characters) at program start via fieldbus
<b>HMI</b>	SFK front end in visual representation only accessible via web browser; all HMI functionalities are also available via REST API; to a limited extent also via OPC-UA
<b>Remote maintenance capability</b>	Access via remote maintenance software (e.g. TeamViewer, VNC Viewer, ...)
<b>Readable variables via OPC-UA</b>	Active program ID, current error, current position, current program step, current force, current speed, system database online (0 or 1), system available (0 or 1), free space, program running (0 or 1)
<b>Methods via OPC-UA</b>	Abort command, delete error, display Y-parameter, position, reboot entire system, read command history, read I/Os, read S or P parameters, read out command with call context, read out SMC variable, read out Y parameters, switch between parameter and operating mode, set program active, set reference, start the program, start the reference run, tare the force sensor, write S or P parameters, write SMC variables, write Y parameters
<b>Retrievable data via REST API</b>	Account data, authentication data, configuration, curves, programs, users, evaluation elements, activity, commissioning
<b>Fieldbus function blocks available for</b>	Siemens TIA Portal, Rexroth Indra Works and Allen Bradley Studio 5000 Logix Designer











# Configuration and CAD data

The definition of the SFK with its nominal forces was based on an internally defined reference cycle. We recommend to calculate every application in our selection and sizing tool LinSelect in order to determine a suitable for the application. On the basis of this selection, CAD files can be generated and downloaded in the online configurator.

## Online tools, support & service



### Online tools, support & service

 <b>LinSelect</b>	 <b>Configurator</b>		
<b>Selection and sizing tool</b>	<b>Configurator</b>	<b>Online Catalog</b>	<b>Technical data sheet</b>
			
<b>Brochure PDF</b>	<b>Success Story</b>	<b>YouTube Playlist</b>	<b>Software</b>

[www.boschrexroth.com/sfk-pressing](http://www.boschrexroth.com/sfk-pressing)

















# Ordering code

<b>Example</b>			<b>004</b>	<b>200</b>	- <b>Axial</b> -	<b>Safe Torque Off</b>	<b>With force sensor</b>	- <b>5</b>
<b>Size</b> dependent on nominal force	=	2 kN: <b>002</b> 4 kN: <b>004</b> 7 kN: <b>007</b> 12 kN: <b>012</b> 19 kN: <b>019</b> 30 kN: <b>030</b> 45 kN: <b>045</b> 70 kN: <b>070</b>						
<b>Travel range</b> dependent on size		002 <b>35 - 400 mm</b> 004 <b>40 - 400 mm</b> 007 <b>65 - 400 mm</b> 012 <b>80 - 400 mm</b> 019 <b>70 - 400 mm</b> 030 <b>90 - 400 mm</b> 045 <b>110 - 400 mm</b> 070 <b>130 - 400 mm</b>						
<b>Motor attachment</b>	=	<b>Axial</b>						
								
		<b>Parallel</b>						
								
<b>Safety function</b> <b>Drive controller</b>	=	<b>Safe Torque Off / Safe Motion</b>						
<b>Force sensor</b> <sup>1)</sup>	=	<b>Without force sensor</b> <b>With force sensor</b>						
<b>Cable length</b>	=	<b>5 m</b> <b>10 m</b>						

<sup>1)</sup> Observe the notes in the chapter "Force sensor"

# Additional documentation

## Required and supplementary documentation

	<b>Title</b>	<b>Document number</b>	<b>Document type</b>
	Electromechanical cylinders EMC	R999000473	Catalog
	Electromechanical cylinders EMC-HP	R999002086	Catalog
	Instructions for electromechanical cylinders EMC	R320103102	Instructions
	Instructions for electromechanical cylinders EMC HP	R320103219	Instructions
	IndraDrive Cs drive assemblies with HCS01	R911322209	Description of the project planning
	MS2N synchronous servo motors	R911347582	Description of the project planning
	IndraControl PR21	R911389663	Instructions
	SMC	R911343864	Manual
	Smart Function Kit	R320103194	Instructions
	Smart Function Kit software	R320103208	Instructions
	Smart Function Kit - Fieldbus	R320103209	Instructions
	Smart Function Kit - OPC-UA + REST-API	R320103210	Instructions
	IndraDrive integrated safety technology "Safe Torque Off" (from MPx-16)	R911332633	Application description
	Integrated safety technology "Safe Motion" (from MPx-18)	R911338919	Application description
	Add-on components and accessories	R911306139	Description of the project planning

The Rexroth documentation is available for download at [www.boschrexroth.com/mediadirectory](http://www.boschrexroth.com/mediadirectory).

## Ambient conditions

<b>Smart Function Kit / size</b>	<b>002</b>	<b>004</b>	<b>007</b>	<b>012</b>	<b>019</b>	<b>030</b>	<b>045</b>	<b>070</b>
<b>Operation ambient temperature</b>	0 °C ... 40 °C, above 40 °C loss of performance							
<b>IP protection class</b>	Mechanics: Standard IP54 (up to IP65 possible) Control cabinet hardware: IP20							
<b>Duty cycle</b>	<b>%</b>	100						

**Bosch Rexroth AG**

Ernst-Sachs-Straße 100  
97424 Schweinfurt, Germany  
Phone +49 9721 937-0  
[www.boschrexroth.com](http://www.boschrexroth.com)

**Find your local contact person here:**

[www.boschrexroth.com/contact](http://www.boschrexroth.com/contact)

