

Ball screw assemblies BASA

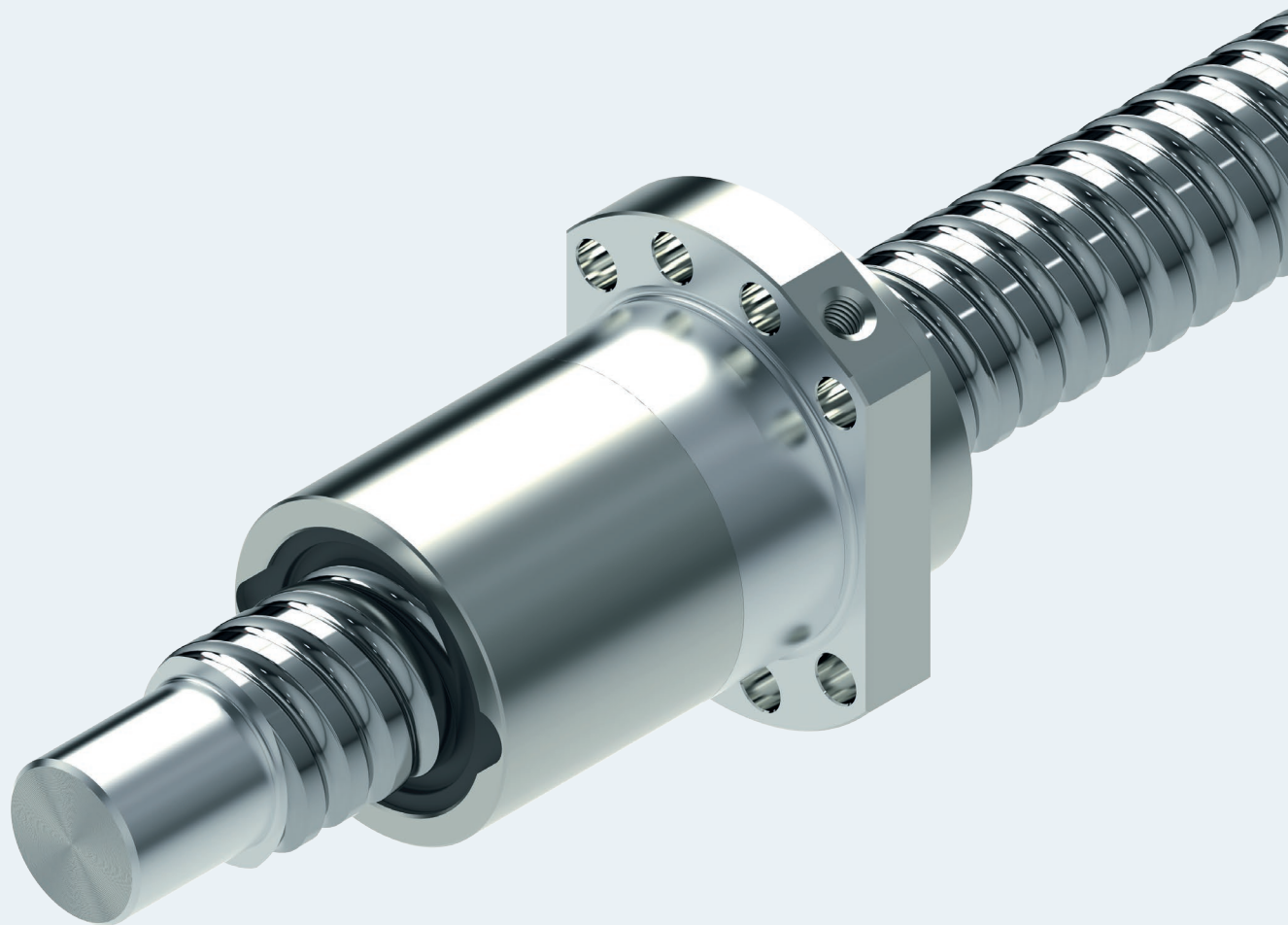

Ball screw assemblies BASA

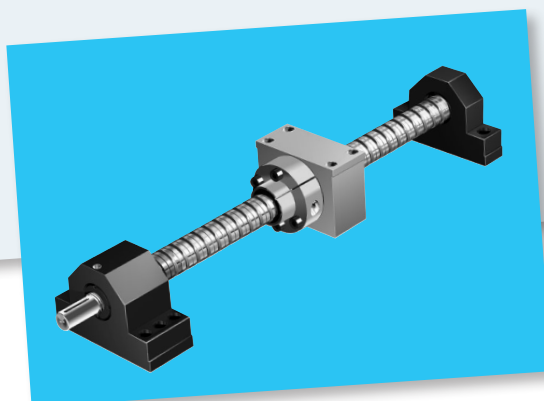
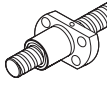
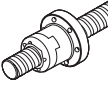
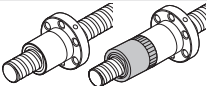
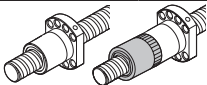
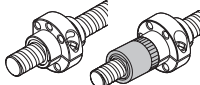
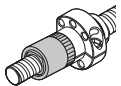
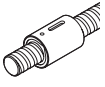
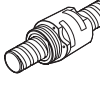
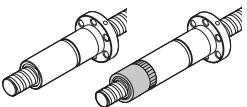

Table of contents: Ball screw assemblies

Table of contents	9	Accessories	92
Product overview	10	Overview	92
Nuts and Nut Housings	10	Nut housing MGS	94
Screws	12	Nut housing MGD	96
Bearing	14	Nut housing MGA	98
Accessories	15	Pillow block unit SEC-F assembly, aluminum	100
Definition of ball screw assembly	16	Pillow block unit SEC-L assembly, aluminum	102
Ball screw assemblies for all applications	18	Pillow block unit SES-F assembly, steel	104
		Pillow block unit SES-L assembly, steel	106
		Pillow block unit SEB-F assembly	108
		Pillow block unit SEB-L assembly	110
		Flange bearing assembly SEE-F-Z	112
		Bearing assembly LAF	114
		Bearing assembly LAN	116
		Bearing assembly LAD	118
		Bearing assembly LAL	120
		Bearing assembly LAS	122
		Slotted Nuts NMA, NMZ and NMG for fixed bearings	124
		Assembly tool for slotted nut	125
		Ring nut GWR	125
		Ball screw assembly with front lube unit	126
		Measuring pads	131
		Arrestor nut	131
		Technical data	132
		Technical notes	132
		Acceptance Conditions and Tolerance Grades	134
		Preload and rigidity	138
		Frictional torques of the seals	144
		Installation	146
		Lubrication	149
		Grease lubrication	150
		Grease lubrication	156
		Oil lubrication	162
		Lubricants	168
		Calculation and examples	170
		Calculation	170
		Critical speed n_{cr}	174
		Permissible axial load on screw F_c (buckling load)	175
		Design of drive unit FAR-B-S	176
		End Bearings	184
		Design notes, installation	184
		Mounting the housing	185
		Lubrication of the end bearings	186
		Calculation	187
		Design Calculation Service Form	189
Sample applications	19		
Inquiries and orders	20		
Nuts, miniature series	24		
Overview of formats	24		
Single nut with flange FEM-E-B	25		
Single nut with flange FEM-E-S	26		
Adjustable-preload single nut SEM-E-S	27		
Cylindrical single nut ZEM-E-S/ZEM-E-K	28		
Screw-in nut ZEV-E-S	29		
Nuts, Speed Series	30		
Single nut with flange with recirculation caps FEP-E-S	31		
Nuts, standard series	32		
Overview of formats	33		
Single nut with flange FEM-E-S	34		
Single nut with flange FEM-E-B	36		
Adjustable-preload single nut SEM-E-S	38		
Adjustable-preload single nut SEM-E-C	40		
Cylindrical single nut ZEM-E-S / ZEM-E-K / ZEM-E-A	42		
Screw-in nut ZEV-E-S	44		
Double nut with flange FDM-E-S	46		
Double nut with flange FDM-E-B	48		
Nuts, high-performance series	50		
Nuts, high-performance series	50		
Single nut with flange FED-E-B	52		
Driven single nut with flange FAR-B-S	54		
Screws	56		
Screw ends	58		
Abbreviations	59		

Nuts and Nut Housings

Nuts	Series	Miniature												Page		
	Size	FEM-E-B	FEM-E-S	SEM-E-S	ZEM-E-S	ZEM-E-K	ZEV-E-S									
Miniature series FEM-E-B / FEM-E-S / SEM-E-S / ZEM-E-S / ZEM-E-K / ZEV-E-S 	$d_0 \times P \times D_w$															from 25
	6 x 1 x 0.8															
	6 x 2 x 0.8															
	8 x 1 x 0.8															
	8 x 2 x 1.2															
	8 x 2.5 x 1.588															
Speed series Single nut with flange with recirculation caps FEP-E-S 	8 x 5 x 1.588														31	
	12 x 2 x 1.2															
	12 x 5 x 2															
	12 x 10 x 2															
Standard series Single nut with flange FEM-E-S 	Series															34
	Speed															
Single nut with flange DIN 69 051, Part 5 FEM-E-B 	Size															36
	$d_0 \times P \times D_w$															
	16 x 5 x 3		L	L	L		L									
	16 x 10 x 3															
	16 x 16 x 3															
	20 x 5 x 3		L	L	L		L	L								
	20 x 10 x 3															
	20 x 20 x 3.5															
	20 x 40 x 3.5															
	25 x 5 x 3		L	L	L		L									
	25 x 10 x 3															
	25 x 25 x 3.5															
	Adjustable-preload single nut SEM-E-S 	32 x 5 x 3.5		L	L	L		L								
32 x 10 x 3.969																
32 x 20 x 3.969																
32 x 32 x 3.969																
32 x 64 x 3.969																
40 x 5 x 3.5			L	L	L		L									
40 x 10 x 6			L	L	L		L									
40 x 12 x 6																
40 x 16 x 6																
40 x 20 x 6																
Adjustable-preload single nut DIN 69051, Part 5 SEM-E-C 	40 x 25 x 6															42
	40 x 30 x 6															
	40 x 40 x 6															
	50 x 5 x 3.5															
	50 x 10 x 6															
	50 x 12 x 6															
	50 x 16 x 6															
	50 x 20 x 6.5															
	50 x 25 x 6.5															
	50 x 30 x 6.5															
Cylindrical single nut ZEM-E-S/ZEM-E-K/ ZEM-E-A 	63 x 10 x 6															44
	63 x 20 x 6.5															
	63 x 40 x 6.5															
	80 x 10 x 6.5															
	80 x 20 x 12.7															
	80 x 40 x 12.7															
Screw-in nut ZEV-E-S 	80 x 10 x 6.5															46
	80 x 20 x 12.7															
	80 x 40 x 12.7															
	80 x 10 x 6.5															
	80 x 20 x 12.7															
	80 x 40 x 12.7															
Double nut with flange FDM-E-S 	80 x 10 x 6.5															48
	80 x 20 x 12.7															
	80 x 40 x 12.7															
	80 x 10 x 6.5															
	80 x 20 x 12.7															
	80 x 40 x 12.7															

Standard range, right-hand lead
L Left-hand lead readily available

High-performance series **Page**

<p>Single nut with flange DIN 69051, Part 5 FED-E-B</p> 		52
<p>Driven single nut with flange FAR-B-S</p> 		54

Nut housing **Page**

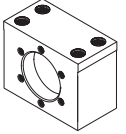
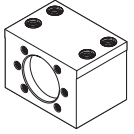
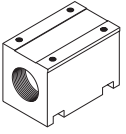
<p>MGS for standard series FEP-E-S FEM-E-S SEM-E-S FDM-E-S</p> 	<p>Lead P</p> <table border="1" style="width: 100%; text-align: center;"> <thead> <tr> <th></th> <th>5</th> <th>10</th> <th>12</th> <th>16</th> <th>20</th> <th>25</th> <th>30</th> <th>32</th> <th>40</th> <th>64</th> </tr> </thead> <tbody> <tr> <th>16</th> <td>A B</td> <td>A B</td> <td></td> <td>A B</td> <td></td> <td></td> <td></td> <td></td> <td></td> <td></td> </tr> <tr> <th>20</th> <td>A B C</td> <td>A B C</td> <td></td> <td></td> <td>A B C</td> <td></td> <td></td> <td></td> <td>A</td> <td></td> </tr> <tr> <th>25</th> <td>A B</td> <td>A B</td> <td></td> <td></td> <td></td> <td>A B</td> <td></td> <td></td> <td></td> <td></td> </tr> <tr> <th>32</th> <td>A B C</td> <td>A B C</td> <td></td> <td></td> <td>A B C</td> <td></td> <td></td> <td>A B C</td> <td></td> <td>A</td> </tr> <tr> <th>40</th> <td>A B C</td> <td>A B C</td> <td>B</td> <td>B</td> <td>A B C</td> <td>B</td> <td>B</td> <td></td> <td>A B C</td> <td></td> </tr> <tr> <th>50</th> <td>A B</td> <td>A B</td> <td>B</td> <td>A B</td> <td>A B</td> <td></td> <td>B</td> <td></td> <td>A B</td> <td></td> </tr> <tr> <th>63</th> <td></td> <td>A B</td> <td></td> <td></td> <td>B</td> <td></td> <td></td> <td></td> <td>B</td> <td></td> </tr> <tr> <th>80</th> <td></td> <td>A B</td> <td></td> <td></td> <td>B</td> <td></td> <td></td> <td></td> <td>B</td> <td></td> </tr> </tbody> </table>		5	10	12	16	20	25	30	32	40	64	16	A B	A B		A B							20	A B C	A B C			A B C				A		25	A B	A B				A B					32	A B C	A B C			A B C			A B C		A	40	A B C	A B C	B	B	A B C	B	B		A B C		50	A B	A B	B	A B	A B		B		A B		63		A B			B				B		80		A B			B				B		94
		5	10	12	16	20	25	30	32	40	64																																																																																										
16	A B	A B		A B																																																																																																	
20	A B C	A B C			A B C				A																																																																																												
25	A B	A B				A B																																																																																															
32	A B C	A B C			A B C			A B C		A																																																																																											
40	A B C	A B C	B	B	A B C	B	B		A B C																																																																																												
50	A B	A B	B	A B	A B		B		A B																																																																																												
63		A B			B				B																																																																																												
80		A B			B				B																																																																																												
<p>MGD for standard series FEM-E-B SEM-E-C FDM-E-B FED-E-B</p> 		96																																																																																																			
<p>MGA for cylindrical single nut ZEM-E-S ZEM-E-K ZEM-E-A</p> 	<p>A = MGS B = MGD C = MGA</p>	98																																																																																																			

Screws

Precision screw BAS		Page
Tolerance grades: T5, T7, T9	<p>Sizes 6 to 12</p> <p>Screw length →</p>	57
Tolerance grades: T5, T7, T9	<p>Left-hand lead</p> <p>Size</p> <p>Screw length →</p>	
Screws in tolerance grade T3 (longer versions and larger sizes available on request)	<p>Screw length →</p> <p> Standard, available at short notice on request </p>	

Precision screw BAS

Tolerance grades:
T5, T7, T9

Page

57

Größen 16 bis 80

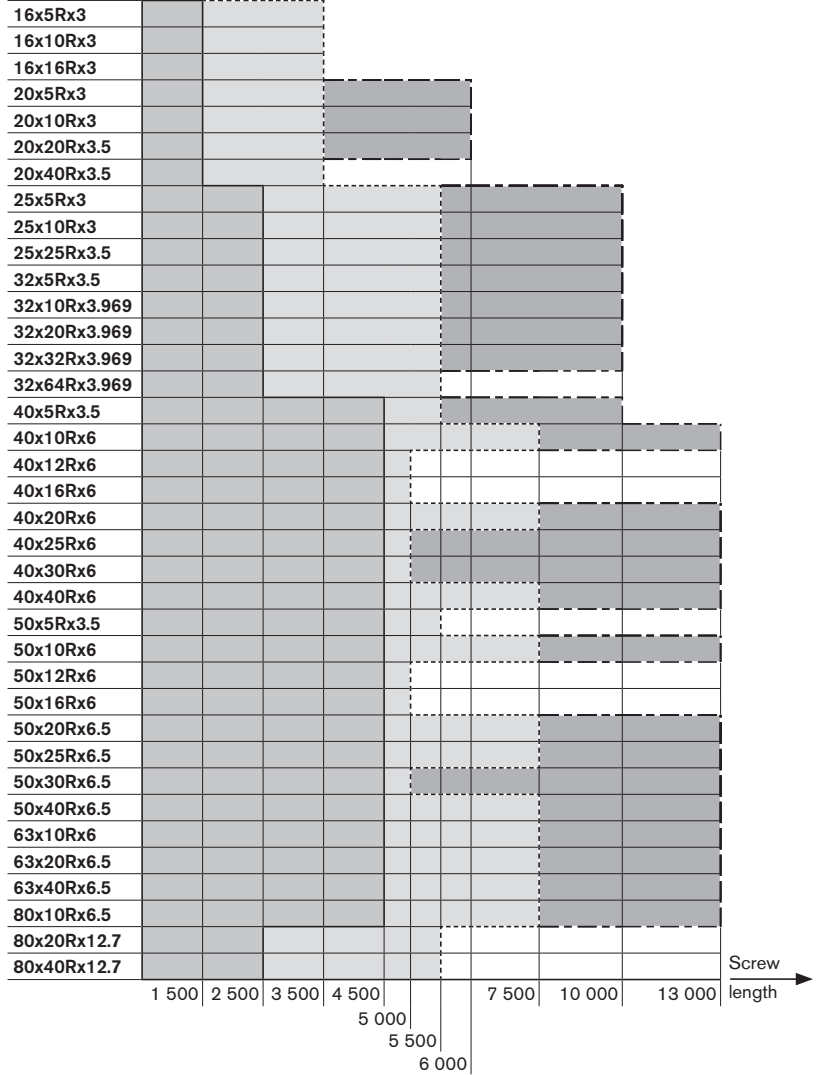

- Standard, available at short notice
- On request
- Maximum length (assembled) on request

Screw ends





Page

58

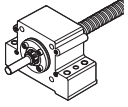
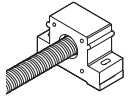
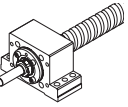
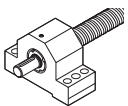
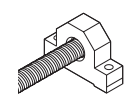
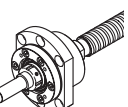
Bearing

Pillow block unit																Page		
SEC-F																100		
SEC-L		Lead P	1	2	2.5	5	10	12	16	20	25	30	32	40	64	102		
SES-F		Diameter d₀	6	A	A													104
			8	A	A	A	A											
			12		A		A											
			16			A		A		A								
			20			ABC	D	ABC	D			ABCD	D			ABC		
			25			A	C	D	A	C	D			A	C			
			32			ABC	D	ABC	D			ABCD	D			ABC		ABC
			40			ABC	D	ABC	D	ABC	ABC	ABC	D	ABC	ABC		ABCD	
			50			A		D	A		D	A	A	A		D	A	A
			63					A					A				A	
			80					A				A					A	
SEB-F		A = SEB-F and SEB-L B = SEC-F and SEC-L C = SES-F and SES-L D = SEE-F														108		
SEB-L																110		
SEE-F-Z																112		

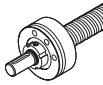
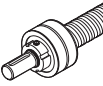
Bearing

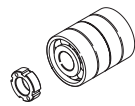
Bearing		Page
LAF		114
LAN		116
LAD		118
LAL		120
LAS		122

Diameter d ₀	Lead p												
	1	2	2,5	5	10	12	16	20	25	30	32	40	64
6	■	■											
8	■	■											
12		■											
16							■						
20				■				■				■	
25				■	■				■				
32				■	■					■		■	
40				■	■	■					■	■	
50				■	■	■	■					■	
63				■	■	■	■	■				■	
80				■	■	■	■	■	■			■	

■ LAF ■ LAN / LAD

Diameter d ₀	Lead p				
	1	2	2,5	5	10
6	■				
8	■				
12		■			
16					
20					
25					
32					







■ LAL

Diameter d ₀	Lead p								
	5	10	12	16	20	25	32	40	64
16	■	■							
20	■	■						■	
25	■	■							
32	■	■							
40	■	■	■						
50	■	■	■	■					
63	■	■	■	■	■				
80	■	■	■	■	■	■			

■ LAS

Accessories

The load capacities of bearing and ball screw drive must be kept in reasonable balance.

Single parts		Page
Slotted nut NMA, NMZ		124
Assembly tool for NMA/NMZ/NMG		125
Ring nut GWR		125
Front lube unit		126
Measuring pads		131
Arrestor nut		131
Acceptance conditions		Page 134

Definition of ball screw assembly

ISO 3408-1 defines a ball screw assembly as follows:

A unit consisting of a ball screw shaft, ball nut and balls which is able to convert rotary motion into linear motion, and vice versa. The basic functioning of a ball screw assembly is easy to describe, but there are numerous different designs and requirements for practical applications.

Several innovations and adaptations have contributed to the extension of the product portfolio.

Rexroth ball screw assemblies provide design engineers with diverse solutions for transport and positioning tasks with driven screws or with driven nuts.

At Rexroth you will be sure to find exactly the kind of tailor-made products you need for special applications.

The flange nuts from the standard series are available in versions with Rexroth or DIN mounting dimensions.

In order to make it easier in future for customers to decide between particular series and/or sizes in terms of delivery time too, we have introduced **A and B** categories for nuts.

Each individual nut part number is assigned to a particular category.

A-nuts (MTS) correspond to the GoTo Europe + premium program, and are always kept in stock in the usual order quantities.

B-nuts (MTO) correspond to the catalog program and must be requested subject to delivery capacity.

For deliveries within Europe, there is the quantity-dependent GoTo Europe Focused Delivery Program.

The special delivery times and quantities can be found in the "GoTo Europe Focused Delivery Program" catalog.

Almost all single nuts in the version with backlash can be easily mounted on the screw by the customer himself, especially during servicing. In addition, the standard series adjustable-preload single nut allows the customer to carry out preload adjustment in-house.

Appropriate nut housings for the standard series and several types of end bearings are also stocked.

Precision screws

in a variety of sizes and of unequalled quality have long been an essential part of our product range. Our comprehensive, world-wide stocks guarantee fast response times in every location. Availability is one advantage, low prices another. Every nut featured in this catalog can be combined with precision screws.

Precision screws can also be supplied without nuts to allow customers to machine the screw ends themselves.

For special servicing jobs, please consult us.

Calculation software and product configuration tool

The Linear Motion Designer (LMD) calculation software is used for designing and calculating ball screw assemblies BASA.

The CAD model is created via the product configuration tool.

This can be accessed via the Rexroth online portal / eConfigurators and Tools.

www.boschrexroth.de/gewindetriebkonfigurator

This online configuration tool makes it possible to visually configure ball screw assemblies quickly to match specific requirements in each case.

The tool automatically checks the plausibility of changed parameters. The link to the eShop means that ball screw assemblies can be directly ordered at any time of the day or night.



Benefits

- Smooth functioning due to the principle of internal recirculation
- Especially smooth running due to the optimal pick-up of balls from the raceway
- Adjustable-pre-tensioned single nut
- High load rating due to large number of balls
- Short nut length
- No protruding parts, nut is easily mounted
- Smooth outer shell
- Effective, wiping sealing
- Large range of series available ex stock

Ball screw assemblies for all applications

Drive units

You will find further system solutions in our catalog on Rexroth Drive Units.

This catalog contains ball screw assemblies with a protecting housing, including versions with integrated screw supports and matching AC servo motors.

To perform particularly demanding positioning tasks we have developed the integrated measuring system for ball rail and roller rail systems. This enables us to achieve maximum design flexibility and operating precision.

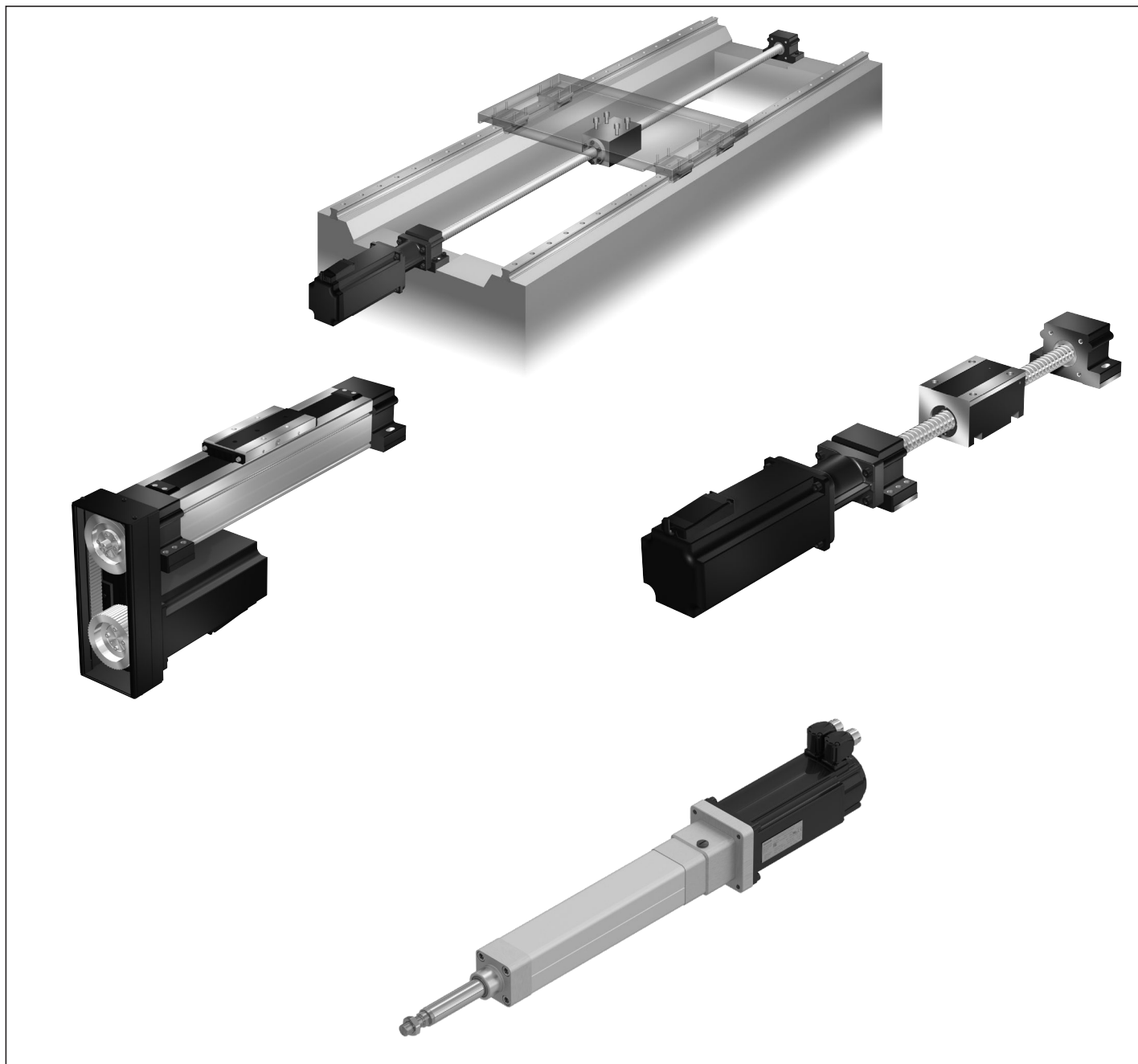

Sample applications

Rexroth ball screw assemblies have been successfully implemented worldwide in the following areas:

- Cutting operations
- Forming operations
- Automation and handling
- Woodworking
- Electrical and electronics
- Printing and paper industry
- Injection molding machines
- Food and packaging industries
- Medical technology
- Textile industry
- etc.

Machining center

Vertical axis with driven nut

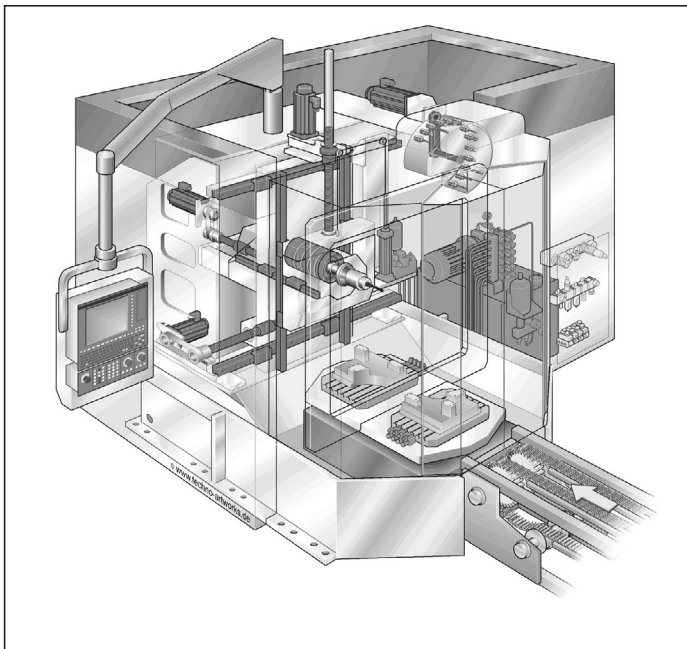

Press brake

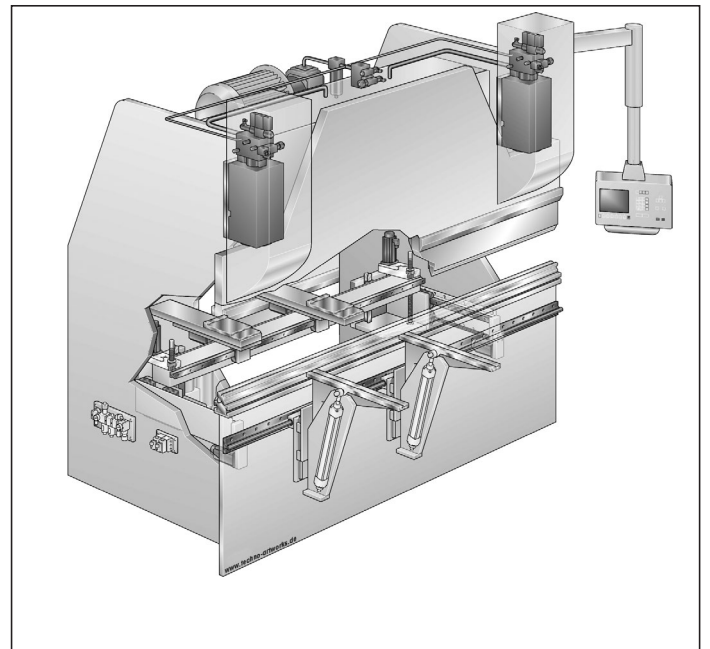

Lathe

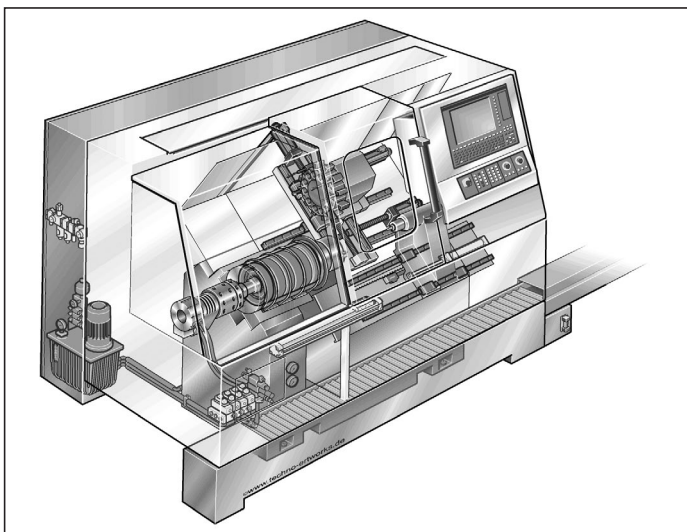

Inquiries and orders

All nuts, screws and end machining details can now be defined with the ordering code as a complete precision ball screw assembly. We have taken account of all the existing selection criteria as well as adding new ones. The diversity of possible combinations and specifications is basically limitless. Attention is focused in particular on the definition of end machining details. For many design versions there is a prepared definition, which means that a suitable solution can be devised for virtually any application. If you wish to send us an inquiry, simply complete the form at the end of this catalog.

- If you submit a manufacturing drawing as a CAD file in Pro/E, STEP or DXF, you can e-mail the data to us.
- If the drawing exists on paper only, we will of course accept a scan or a drawing sent by conventional mail.
- If no drawing is available, please specify your wishes using the variable ordering code. The available options are shown at several places in the catalog.

Each customer-specific ball screw assembly is issued with an ID number when an order is placed. For queries or repeat orders, simply quote this number. If you know the specific ordering code you can also easily generate a CAD drawing yourself in numerous file formats via the functionality provided on our website.

Rexroth offers an online product configuration tool for this and for directly submitting product requests.

To configure specific solutions quickly and easily, simply go to www.boschrexroth.de/gewindetrieb-konfigurator.

This online tool enables you to visually configure the specific ball screw assembly or planetary screw assembly that you need. You can select any catalog option or any defined product modification. The tool automatically checks the plausibility of changed parameters. Once configuration is complete, 2D and 3D data is available for download in all established formats. As regards end machining, you can choose either standard versions or tailor-made solutions. Rexroth machines the screw ends of the ball screw assembly or planetary screw assembly so that it matches the customer's connecting design and fulfills the desired requirements. The configuration tool which is incorporated into the eShop allows you to obtain a price for customer-specific ball screw assemblies, and also to directly order the product.

The screw diameter size that can be selected for ball screw assemblies ranges from 6 to 80 millimeters. In addition, any type of nut can be chosen.

Rexroth The Drive & Control Company
Bosch Group

Ball Screw Assembly

Nominal Diameter

6 d ₀ = 6 mm	8 d ₀ = 8 mm
12 d ₀ = 12 mm	16 d ₀ = 16 mm
20 d ₀ = 20 mm	25 d ₀ = 25 mm
32 d ₀ = 32 mm	40 d ₀ = 40 mm
50 d ₀ = 50 mm	63 d ₀ = 63 mm
80 d ₀ = 80 mm	

Product Information
 Consultation request
 Restart selection
 myConfiguration
 open
 save
 Configuration
 Type: KGT
 Nominal Diameter
 Lead
 Direction of Lead
 Nut Type
 Ball diameter
 Precision
 Flute
 Left screw end
 Flute
 Version
 Option
 Right screw end
 Flute
 Version
 Option
 Length
 Documentation

© Bosch Rexroth AG

Newsletter | Imprint | Privacy | Legal | Certificates | Purchasing and Logistics | © Bosch Rexroth AG | Facebook | YouTube | LinkedIn | To the top

Rexroth The Drive & Control Company
Bosch Group

You are here: Home > Products > Product Group > Linear Motion Technology catalog > Linear Screw Assemblies > Ball Screw Assemblies

Ball Screw Assembly

Version screw end left

Version
 151
 170
 175
 individually configured, max. Ø 20.9 mm, max. offset length 125 mm

Technical drawing showing dimensions: Ø 12_{h7}, M18x1, Ø 16_{h8}, 50, 16, 19, 85.

Legend
 10.00 fixed dimension
 10.00 individually configured dimension
 10.00 individually configured dimension
 10.00 dimension outside the limit values

Product Information
 Consultation request
 Restart selection
 myConfiguration
 open
 save
 Configuration
 Type: KGT
 Nominal Diameter: 25
 Lead: 10
 Direction of Lead: R
 Nut Type: ZEM E S
 Ball diameter: 3
 Number of start threads: 4
 Nut: R151224912
 Seal: none
 Preload: C0
 Lubrication: Pre-lubricated
 Precision: T3
 Screw: R
 Left screw end: F
 Form: B1
 Version
 Option
 Right screw end
 Flute
 Version
 Option
 Length
 Documentation

© Bosch Rexroth AG

Newsletter | Imprint | Privacy | Legal | Certificates | Purchasing and Logistics | © Bosch Rexroth AG | Facebook | YouTube | LinkedIn | To the top

Customers who are registered in the eShop can generate manufacturing drawings as well as requesting CAD models. This drawing can then be used directly by our production departments, which accelerates order processing and delivery. What's more, in this case you can order directly in the eShop.



In the case of configuration without prior registration, only CAD models are provided. We can refer to this if an order is placed, and use it to produce a manufacturing drawing.

Access the eShop via this link: <https://www.boschrexroth.com/eshop>

The ordering code provided on page 22 covers all the parameters of a ball screw assembly. Once you have defined the nominal diameter and lead and entered the total length, the functionality guides you through a succession of dialog boxes allowing you to select the desired options.

Nominal diameters, leads

		Lead P												
		1	2	2,5	5	10	12	16	20	25	30	32	40	64
Nominal diameter d ₀	6													
	8													
	12													
	16													
	20													
	25													
	32													
	40													
	50													
	63													
	80													

-  Available ball nut sizes
-  Combinable with VSE

Overall length L_{tot} of a ball screw assembly

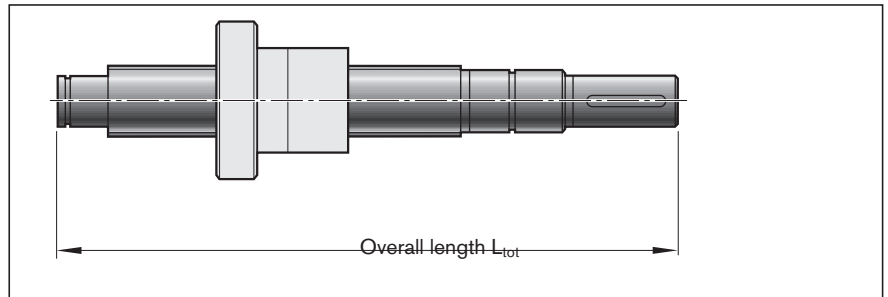

Identification system for short product names BASA / ordering data

Ball screw assembly	BASA	20	x	5	R	x3	FEM-E-B	-	4	00	1	2	T7	R	81	A	Z	120	41	A	Z	120	1234.5	0	1							
Size	Nominal diameter (mm)		Lead (mm)		Direction of lead R ... right, L ... left		Ball diameter (mm)		FEM-E-B Single nut with flange miniature series		SEM-E-S Adjustable-preload single nut		SEM-E-C Adjustable-preload single nut DIN 69051, Part 5		ZEM-E-S Cylindrical single nut		ZEM-E-K Cylindrical single nut		ZEM-E-A Cylindrical single nut		ZEV-E-S Screw-in nut		FDM-E-S ⁴⁾ Double nut with flange		FDM-E-B ⁴⁾ Double nut with flange DIN 69051, Part 5		FED-E-B Single nut with flange		FAR-B-S Driven single nut with flange		Number of ball track turns in the nut	
Nut type	FEP-E-S Single nut with flange with recirculation caps		FEM-E-S Single nut with flange		FEM-E-B Single nut with flange DIN 69051, Part 5		SEM-E-S Adjustable-preload single nut		SEM-E-C Adjustable-preload single nut DIN 69051, Part 5		ZEM-E-S Cylindrical single nut		ZEM-E-K Cylindrical single nut		ZEM-E-A Cylindrical single nut		ZEV-E-S Screw-in nut		FDM-E-S ⁴⁾ Double nut with flange		FDM-E-B ⁴⁾ Double nut with flange DIN 69051, Part 5		FED-E-B Single nut with flange		FAR-B-S Driven single nut with flange		Number of ball track turns in the nut					
Nut rework	00 ... no rework		02 ... axial lube point																													
Sealing system	0 ... no seals		2 ¹⁾ ... reinforced seal		1 ... standard seal		3 ²⁾ ... low-friction seal																									
Preload classes	0 ... C0 (standard backlash)		4 ... C4 (high preload DN ⁶⁾)		1 ... C00 (reduced backlash)		5 ... C5 (average preload DN ⁶⁾)		2 ... C3 ³⁾ (high preload SN ⁵⁾)		6 ... C2 (average preload SN)		3 ... C1 (slight preload SN ⁵⁾)																			
Accuracy	T3, T5, T7 , T9																															
Screw	R ... Precision screw BAS																															
Left screw end	Form:		... standard form		... A with wrench flat on the ball screw		... B with wrench flat on the collar		Option		Z ... centering per DIN 332-D		(machining of end face):		S... hex socket		G... female thread		K... none		Versions:		... standard version									
Right screw end			... see left screw end																													
Overall length [mm]																																
Documentation	0 ... Standard (acceptance test report)		2 ... Torque test report		1 ... Lead test report		3 ... Lead and torque test report		5 ... Two-point compensation		6 ... Torque test report and Two-point compensation																					
Lubrication	0 ... Preserved		1 ... Preserved and nut with basic greasing		2 ... Front lube unit on left, ball nut with basic greasing		3 ... Front lube unit on right, ball nut with basic greasing		4 ... Front lube unit at both ends, ball nut with basic greasing																							

1) only for d₀ 25 to 63; consider the higher frictional torque! See page 144
 2) See page 144 for sizes
 3) only for d₀ 16 to 80
 4) FDM-E-S and FDM-E-B only available as a complete ball screw assembly.
 5) SN = Single nut
 6) DN = Double nut

Mounting direction of nut types

Definition: The centering diameter on a nut with flange, the slotted nut on a driven nut, and the lube bore on a cylindrical nut points to the right end of the screw.

Note: The front lube unit is delivered ready-mounted to the ball screw assembly.

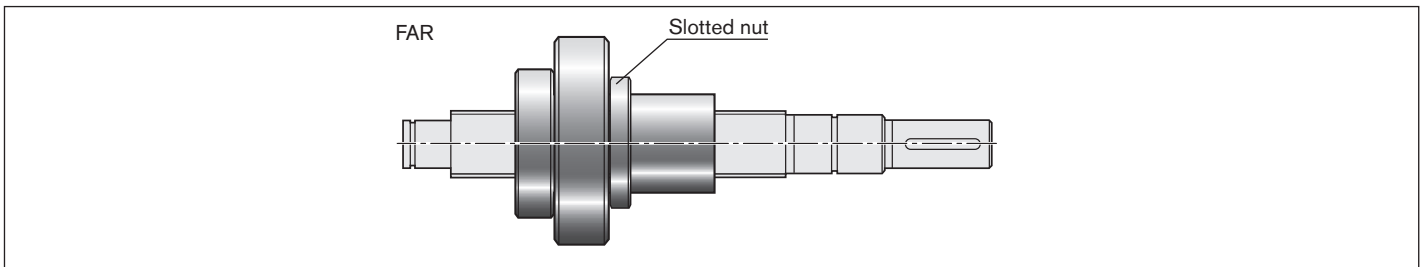
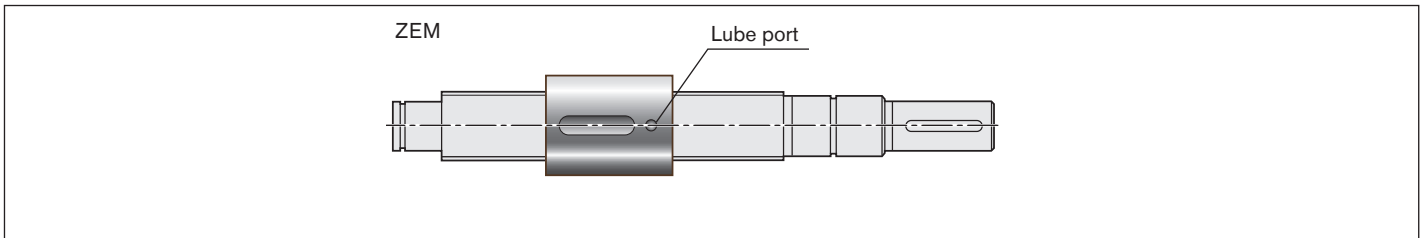
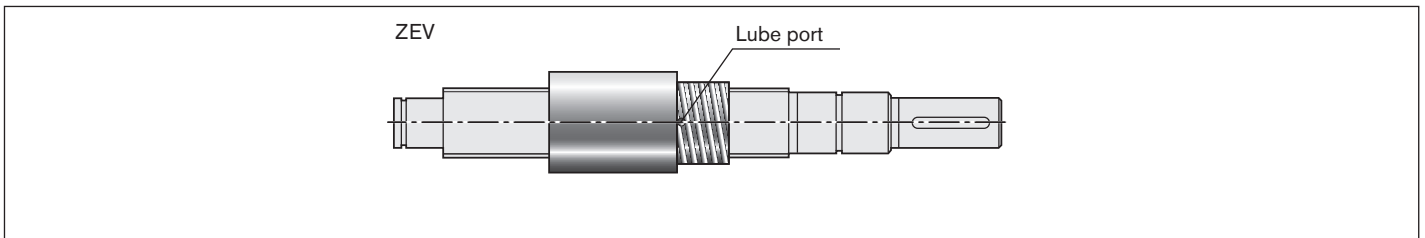
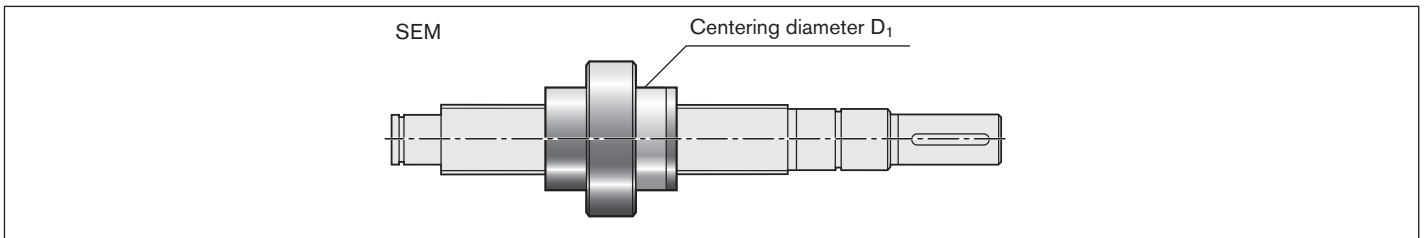
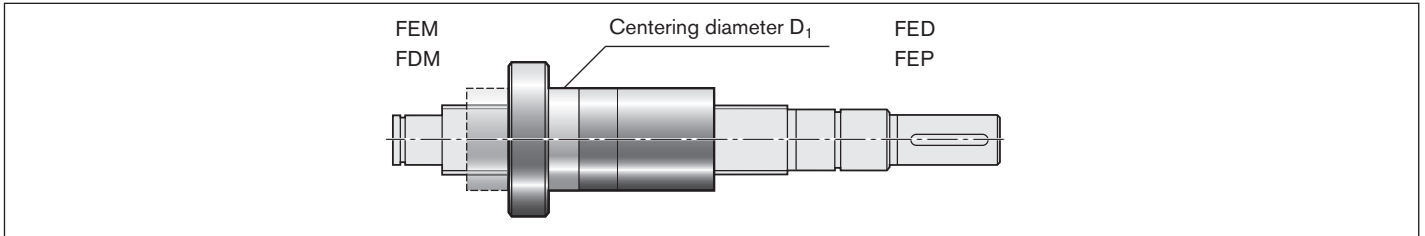

Ball screw assemblies BASA

Nuts, miniature series

Miniature series

Miniature series ball screw assemblies are available with nominal diameters of 6 – 12 mm, and leads of 1 – 10 mm.

The nut types are flange, cylindrical and adjustable-preload single nuts as well as screw-in nuts.

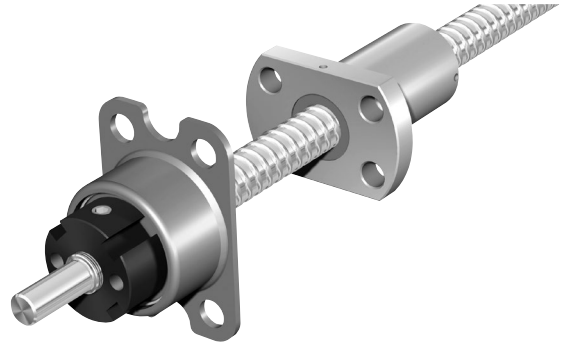

Overview of formats



Preload classes

Option	Preload class	Definition
0	C0	Standard backlash
1	C00	Reduced backlash
2	C3	High preload (single nut)
3	C1	Moderate preload (single nut)
4	C4	High preload (double nut)
5	C5	Average preload (double nut)
6	C2	Average preload (single nut)

See nut versions for allocation of the preload classes

Single nut with flange FEM-E-B

Rexroth connection dimensions flange type B

With seals, preload class: C0, C00
Except for size 8 x 2.5 and 12 x 5/10:
Preload class C1.
Tolerance grade: T5, T7, T9



Ordering data:

BASA	8 x 2R x 1.2	FEM-E-B - 4	00	1	1	T7	R	831K062	41K050	250	0	1
------	--------------	-------------	----	---	---	----	---	---------	--------	-----	---	---

d_0 = nominal diameter
 P = lead
(R = right-hand side)
 D_w = ball diameter
 i = number of ball track turns

Category	Size $d_0 \times P \times D_w - i$	Part number	Load ratings ³⁾		Linear speed ¹⁾ v_{max} (m/min)
			dyn. C (N)	stat. C ₀ (N)	
A	6 x 1R x 0.8 - 3 ²⁾	R1532 100 16	1,080	1,030	6
A	6 x 2R x 0.8 - 3 ²⁾	R1532 120 16	1,070	1,020	12
A	8 x 1R x 0.8 - 4 ²⁾	R1532 200 16	1,310	1,850	6
A	8 x 2R x 1.2 - 4 ²⁾	R1532 220 16	2,360	2,950	12
A	8 x 2.5R x 1.588 - 3	R1532 230 06	2,640	2,800	15
B	8 x 5R x 1.588 - 3	R1532 260 06	2,500	2,650	30
A	12 x 2R x 1.2 - 4 ²⁾	R1532 420 06	2,690	4,160	12
A	12 x 5R x 2 - 3	R1532 460 06	4,560	5,800	30
A	12 x 10R x 2 - 2	R1532 490 06	3,000	3,600	60

- 1) See "Characteristic speed $d_0 \cdot n$ " on page 133 and "Critical speed n_{cr} " on page 174
- 2) Supplied only as complete ball screw assembly.
- 3) The load ratings are valid for tolerance grade T3 and T5 only.
For other tolerance grades, please take into account the correction factor f_{ac} on page 133.

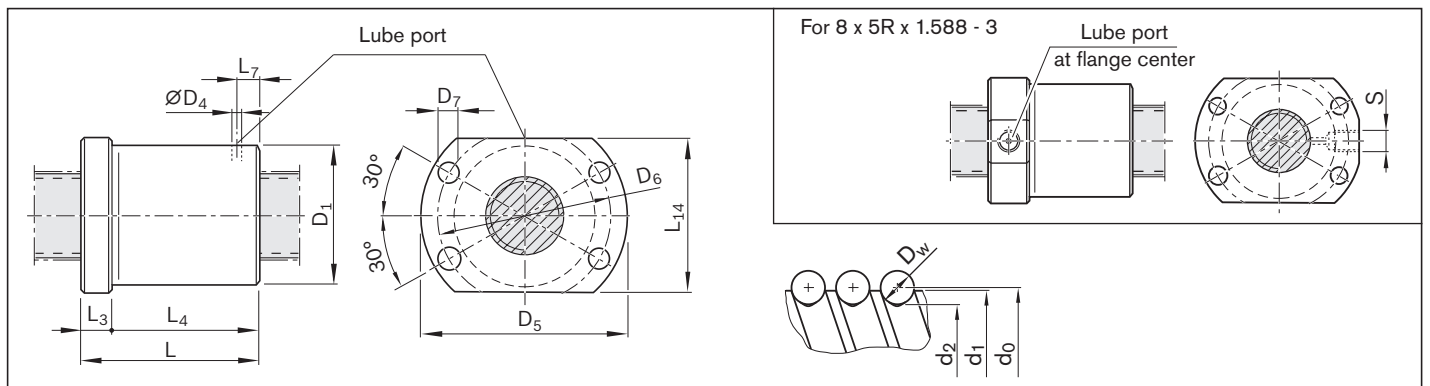

Size	(mm)													Mass m (kg)
	d_1	d_2	D_1 g6	D_4	D_5	D_6	D_7	L	L_3	L_4	L_7	L_{14}	S	
$d_0 \times P \times D_w - i$														
6 x 1R x 0.8 - 3	6.0	5.3	12	1.5	24	18	3.4	11.6	3.5	8.1	3.5	16	-	0.020
6 x 2R x 0.8 - 3	6.0	5.3	12	1.5	24	18	3.4	14.6	3.5	11.1	3.0	16	-	0.020
8 x 1R x 0.8 - 4	8.0	7.3	16	1.5	28	22	3.4	15.5	6.0	9.5	3.5	19	-	0.035
8 x 2R x 1.2 - 4	8.0	7.0	16	1.5	28	22	3.4	19.5	6.0	13.5	3.0	19	-	0.050
8 x 2.5R x 1.588 - 3	7.5	6.3	16	2.0	28	22	3.4	16.0	6.0	10.0	3.0	19	-	0.030
8 x 5R x 1.588 - 3	7.5	6.3	16	-	28	22	3.4	23.5	6.0	17.5	-	19	M3	0.050
12 x 2R x 1.2 - 4	11.7	10.8	20	2.0	37	29	4.5	19.0	8.0	11.0	2.5	24	-	0.055
12 x 5R x 2 - 3	11.4	9.9	22	2.0	37	29	4.5	28.0	8.0	20.0	6.0	24	-	0.075
12 x 10R x 2 - 2	11.4	9.9	22	2.0	37	29	4.5	33.0	8.0	25.0	8.0	24	-	0.085

Single nut with flange FEM-E-S

Rexroth connection dimensions

With seals
Preload class: C0, C00, C1
Tolerance grade: T5, T7, T9

d_0 = nominal diameter
 P = lead (R = right-hand)
 D_w = ball diameter
 i = number of ball track turns



Ordering data:

BASA	12 x 5R x 2	FEM-E-S - 3	00	1	1	T7	R	81K060	41K060	250	0	1
------	-------------	-------------	----	---	---	----	---	--------	--------	-----	---	---

Category	Size $d_0 \times P \times D_w - i$	Part number	Load ratings ²⁾		Linear speed ¹⁾ v_{max} (m/min)
			dyn. C (N)	stat. C ₀ (N)	
A	8 x 2.5R x 1.588 - 3	R1532 230 03	2,640	2,800	15
A	12 x 5R x 2 - 3	R1532 460 23	4,560	5,800	30
A	12 x 10R x 2 - 2	R1532 490 13	3,000	3,600	60

- See "Characteristic speed $d_0 \cdot n$ " on page 133 and "Critical speed n_{cr} " on page 174
- The load ratings are valid for tolerance grade T5 only.
For other tolerance grades, please take into account the correction factor f_{ac} on page 133.

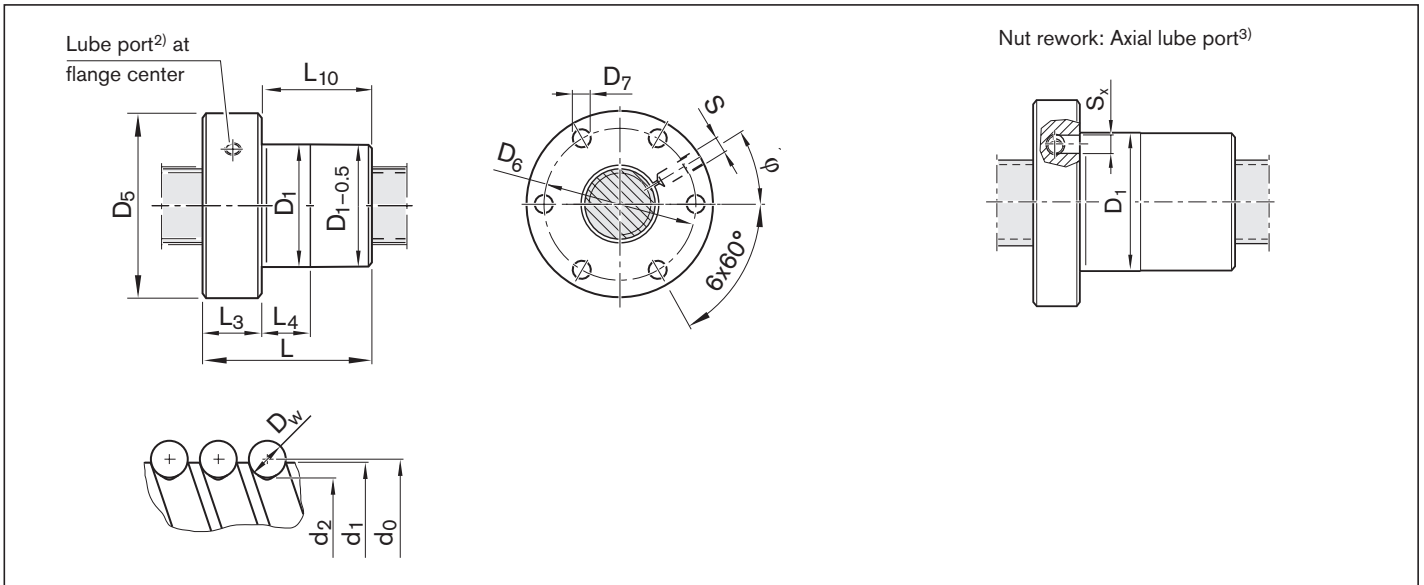

3) The axial lube port S_x is always located on the pitch circle D_6 of the nut unit.

Size	(mm)											Mass		
	d_1	d_2	D_1 g6	D_5	D_6	D_7	L	L_3	L_4	L_{10}	$S^4)$	S_x	φ (°)	m (kg)
$d_0 \times P \times D_w - i$														
8 x 2.5R x 1.588 - 3	7.5	6.3	16	30	23	3.4	16	8	8.0	8	Ø4	-	30.0	0.05
12 x 5R x 2 - 3	11.4	9.9	24	40	32	4.5	28	12	10.0	16	M6	4	330.0	0.12
12 x 10R x 2 - 2	11.4	9.9	24	40	32	4.5	33	12	16.0	21	M6	4	330.0	0.14

4) Lube port machining: flat surface $L_3 \leq 15$ mm, for size 8 x 2.5 a DIN 3405 funnel-type lube nipple is provided.

Adjustable-preload single nut SEM-E-S

Rexroth connection dimensions

With seals
Adjustable preload
Tolerance grade: T5, T7



d_0 = nominal diameter
 P = lead (R = right-hand)
 D_w = ball diameter
 i = number of ball track turns

Ordering data:

BASA	12 x 5R x 2	SEM-E-S - 3	00	1	2	T7	R	81K060	41K060	250	0	1
------	-------------	-------------	----	---	---	----	---	--------	--------	-----	---	---

Category	Size $d_0 \times P \times D_w - i$	Part number	Load ratings ²⁾		Linear speed ¹⁾ v_{max} (m/min)	Centering diameter D_1 after adjustment	
			dyn. C (N)	stat. C_0 (N)		min. (mm)	max. (mm)
B	8 x 2.5R x 1.588 - 3	R1532 230 04	2,640	2,800	15	15.953	15.987
A	12 x 5R x 2 - 3	R1532 460 24	4,560	5,800	30	23.940	23.975
B	12 x 10R x 2 - 2	R1532 490 14	3,000	3,600	60	23.940	23.975

1) See "Characteristic speed $d_0 \cdot n$ " on page 133 and "Critical speed n_{cr} " on page 174

2) The load ratings are valid for tolerance grade T3 and T5 only. For other tolerance grades, please take into account the correction factor f_{ac} on page 133.

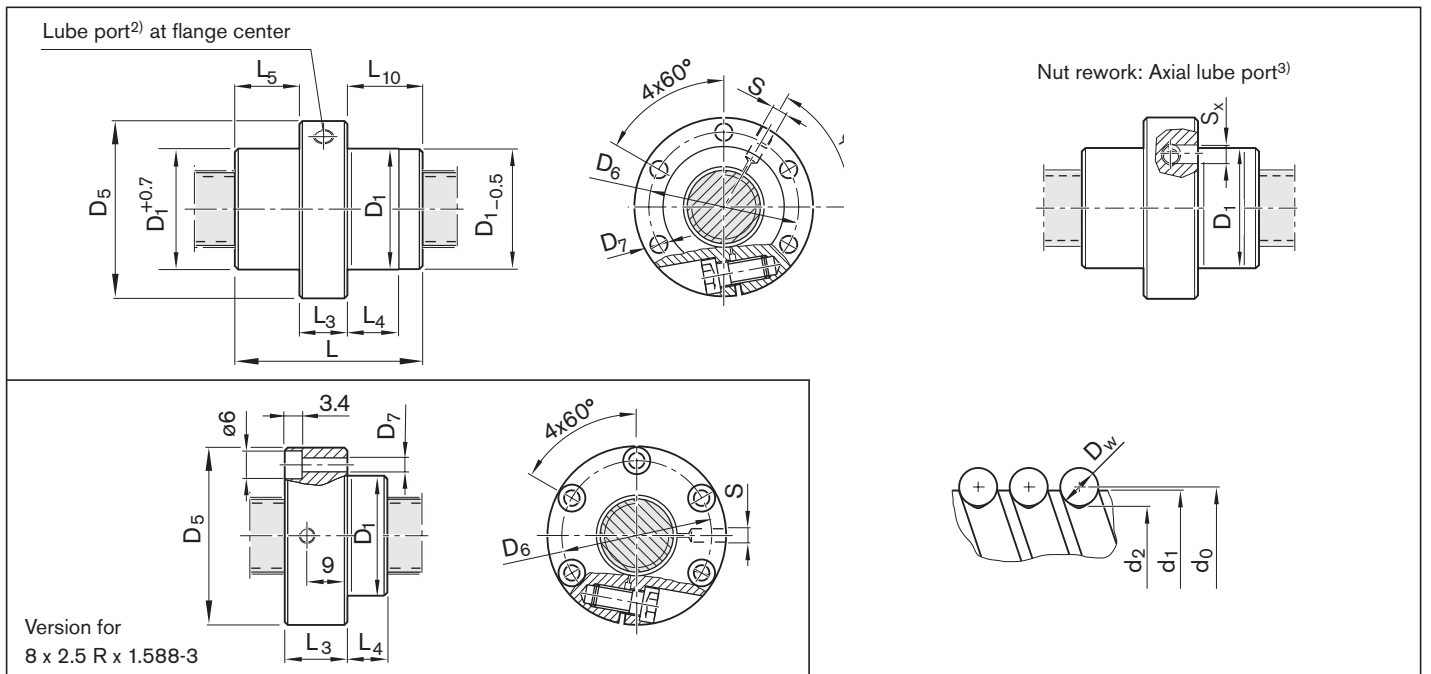

3) The axial lube port S_x is always located on the pitch circle D_6 of the nut unit.

Size	(mm)														Mass	
	d_1	d_2	D_1 f9	D_5	D_6	D_7	L	L_3	L_4	L_5	L_{10}	$S^4)$	S_x	φ (°)	m (kg)	
8 x 2.5R x 1.588 - 3	7.5	6.3	16	30	23	3.4	16	13	3.0	—	3.0	Ø4	—	0	0.06	
12 x 5R x 2 - 3	11.4	9.9	24	40	32	4.5	28	12	8.0	8.0	8.0	M6	4	55	0.12	
12 x 10R x 2 - 2	11.4	9.9	24	40	32	4.5	33	12	10.5	10.5	10.5	M6	4	55	0.13	

4) Lube port machining: flat surface $L_3 \leq 15$ mm, for size 8 x 2.5 a DIN 3405 funnel-type lube nipple is provided.

Cylindrical single nut ZEM-E-S/ZEM-E-K

Rexroth connection dimensions

With seals

Preload class: C0, C00, C1

Except for size 6 x 1/2, 8 x 1/2, 12 x 2:

Preload class C0, C00

Tolerance grade: T5, T7, T9



Ordering data:

BASA	12 x 5R x 2	ZEM-E-S - 3	00	1	1	T7	R	81K060	41K060	250	0	1
------	-------------	-------------	----	---	---	----	---	--------	--------	-----	---	---

d_0 = nominal diameter
P = lead (R = right-hand)
 D_w = ball diameter
i = number of ball track turns

Category	Size $d_0 \times P \times D_w - i$	Part number	Load ratings ³⁾		Linear speed ²⁾	
			dyn. C (N)	stat. C ₀ (N)	v_{max} (m/min)	
B	6 x 1R x 0.8 - 3 ¹⁾	R1532 102 10	1 080	1 030		6
B	6 x 2R x 0.8 - 3 ¹⁾	R1532 122 10	1 070	1 020		12
B	8 x 1R x 0.8 - 4 ¹⁾	R1532 202 10	1 310	1 850		6
A	8 x 2R x 1.2 - 4 ¹⁾	R1532 222 10	2 360	2 950		12
A	8 x 2.5R x 1.588 - 3	R1532 230 02	2,640	2,800		15
B	8 x 5R x 1.588 - 3	R1532 260 02	2 500	2 650		30
A	12 x 2R x 1.2 - 4 ¹⁾	R1532 422 01	2,690	4,160		12
A	12 x 5R x 2 - 3	R1532 460 32	4,560	5,800		30
A	12 x 5R x 2 - 3	R1532 462 25	4,560	5,800		30
A	12 x 10R x 2 - 2	R1532 490 22	3,000	3,600		60
A	12 x 10R x 2 - 2	R1532 492 00	3,000	3,600		60

- 1) Supplied only as complete ball screw assembly.
- 2) See "Characteristic speed $d_0 \cdot n$ " on page 133 and critical speed n_{cr} on page 174
- 3) The load ratings are valid for tolerance grade T5 only. For other tolerance grades, please take into account the correction factor f_{ac} on page 133.

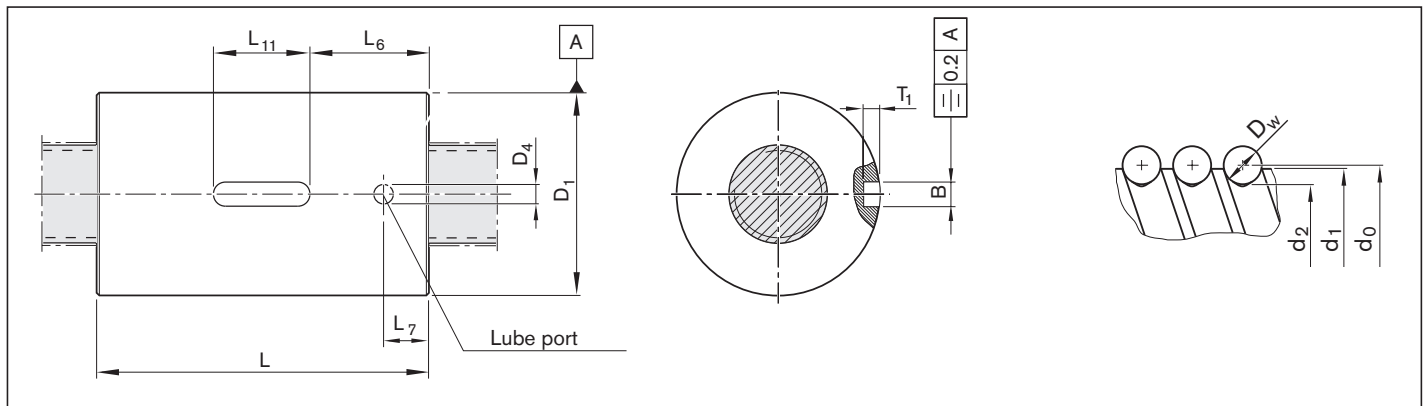

Size $d_0 \times P \times D_w - i$	(mm)										Mass m (kg)
	d_1	d_2	D_1 g6	D_4	L ± 0.1	L_6	L_7	L_{11} $+0.2$	B P9	T_1 $+0.1$	
6 x 1R x 0.8 - 3 ¹⁾	6.0	5.3	12	1.5	11.6	-	3.5	-	-	-	0.014
6 x 2R x 0.8 - 3 ¹⁾	6.0	5.3	12	1.5	14.6	-	3.1	-	-	-	0.015
8 x 1R x 0.8 - 4 ¹⁾	8.0	7.3	16	1.5	15.5	5.00	3.5	6	3	1.2	0.023
8 x 2R x 1.2 - 4 ¹⁾	8.0	7.0	16	1.5	19.5	5.00	3.1	6	3	1.8	0.037
8 x 2.5R x 1.588 - 3	7.5	6.3	16	2	16.0	5.00	3.5	6	3	1.8	0.02
8 x 5R x 1.588 - 3	7.5	6.3	16	2	23.5	7.75	3.5	8	3	1.8	0.04
12 x 2R x 1.2 - 4 ¹⁾	11.7	10.8	21	2	19.0	5.50	3.5	8	3	1.8	0.03
12 x 5R x 2 - 3	11.4	9.9	24	2	28.0	8.00	3.5	12	5	3.0	0.06
12 x 5R x 2 - 3	11.4	9.9	21	2	28.0	8.00	3.5	12	3	1.8	0.04
12 x 10R x 2 - 2	11.4	9.9	24	2	33.0	10.50	3.5	12	5	3.0	0.07
12 x 10R x 2 - 2	11.4	9.9	21	2	33.0	10.50	3.5	12	3	1.8	0.05

Screw-in nut ZEV-E-S

Rexroth connection dimensions

With low-friction seal,
preload class: C0, C00, C1

Tolerance grade: T5, T7, T9



- d_0 = nominal diameter
- P = lead (R = right-hand)
- D_w = ball diameter
- i = number of ball track turns

Ordering data:

BASA	12 x 5R x 2	ZEV-E-S - 3	00	3	1	T7	R	81K060	41K060	250	0	1
------	-------------	-------------	----	---	---	----	---	--------	--------	-----	---	---

Category	Size $d_0 \times P \times D_w - i$	Part number	Load ratings ²⁾		Linear speed ¹⁾
			dyn. C (N)	stat. C ₀ (N)	v_{max} (m/min)
B	8 x 2.5R x 1.588 - 4	R2542 230 05	3,490	3,910	15.0
A	12 x 5R x 2 - 3	R2542 430 05	4,560	5,800	30.0
A	12 x 10R x 2 - 2	R2542 430 15	3,000	3,600	60.0

- 1) See "Characteristic speed $d_0 \cdot n$ " on page 133 and "Critical speed n_{cr} " on page 174
- 2) The load ratings are valid for tolerance grade T3 and T5 only.
For other tolerance grades, please take into account the correction factor f_{ac} on page 133.

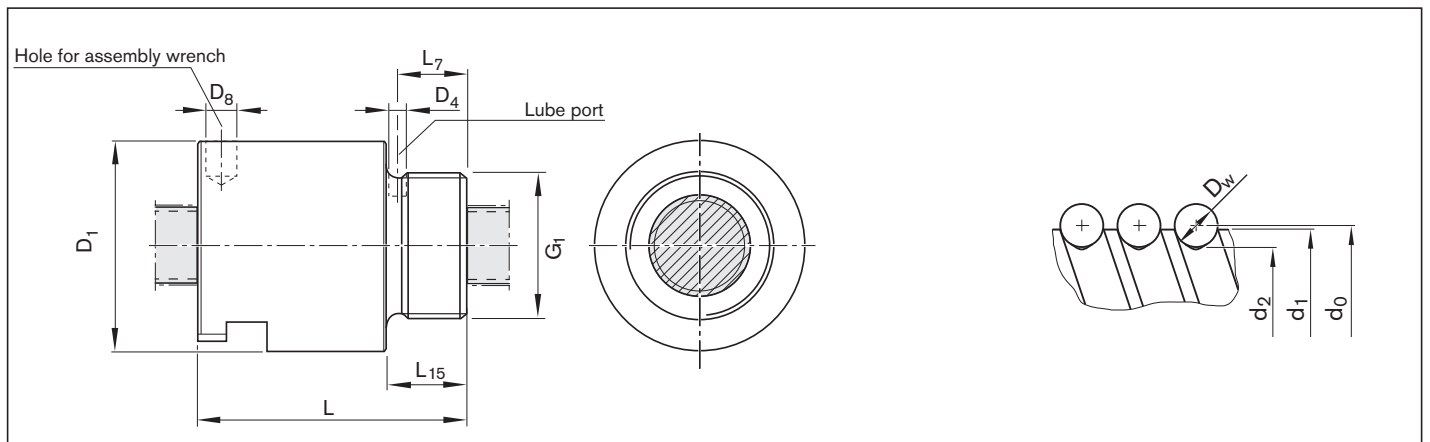

Size	(mm)							L	L ₇	L ₁₅	Mass	
	d_1	d_2	D_1 h10	D_4	D_8	G_1	m (kg)					
$d_0 \times P \times D_w - i$							± 0.3					
8 x 2.5R x 1.588 - 4	7.5	6.3	20.0	1.5	3.2	M18x1	20.5	6.7	8	0.06		
12 x 5R x 2 - 3	11.4	9.9	25.5	2.7	3.2	M20 x 1.0	36	8.5	10	0.09		
12 x 10R x 2 - 2	11.4	9.9	25.5	2.7	3.2	M20 x 1.0	40	8.5	10	0.10		

Nuts, Speed Series

Speed series

Speed series ball screw assemblies are available with nominal diameters of 20 – 32 mm, and leads of 25 – 64 mm.

The nut type is a single nut with flange.

The distinguishing feature of the speed series is its compact design.

Multi-start screws allow a higher load rating with a short nut. The oversquare leads enable the realization of high traversing speeds.



Preload classes

Option	Preload class	Definition
0	C0	Standard backlash
1	C00	Reduced backlash
2	C3	High preload (single nut)
3	C1	Moderate preload (single nut)
4	C4	High preload (double nut)
5	C5	Average preload (double nut)
6	C2	Average preload (single nut)

See nut versions for allocation of the preload classes

Single nut with flange with recirculation caps FEP-E-S

Rexroth connection dimensions

With seals, preload class: C0, C00, C1
Tolerance grade: T5, T7, T9

⚠ Do not exert force on the plastic recirculation caps or allow them to collide with end stops.

Note: Supplied only as complete ball screw assembly.



Ordering data:

BASA	25 x 25R x 3.5	FEM-E-S - 4.8	00	1	0	T5	R	81K170	41K170	1100	0	1
------	----------------	---------------	----	---	---	----	---	--------	--------	------	---	---

d_0 = nominal diameter
P = lead (R = right-hand)
 D_w = ball diameter
i = number of ball track turns

Category	Size $d_0 \times P \times D_w - i$	Part number	Load ratings ²⁾		Linear speed ¹⁾ v_{max} (m/min)
			dyn. C (N)	stat. C ₀ (N)	
A	20 x 40R x 3.5 - 4	R2522 100 11	14,000	26,200	240
A	25 x 25R x 3.5 - 4.8	R2522 200 01	19,700	39,400	150
A	32 x 32R x 3.969 - 4.8	R2522 300 01	26,300	57,600	150
A	32 x 64R x 3.969 - 4	R2522 300 21	21,100	49,000	300

1) See "Characteristic speed $d_0 \cdot n$ " on page 133 and "Critical speed n_{cr} " on page 174

2) The load ratings are valid for tolerance grade T3 and T5 only.

For other tolerance grades, please take into account the correction factor f_{ac} on page 133.

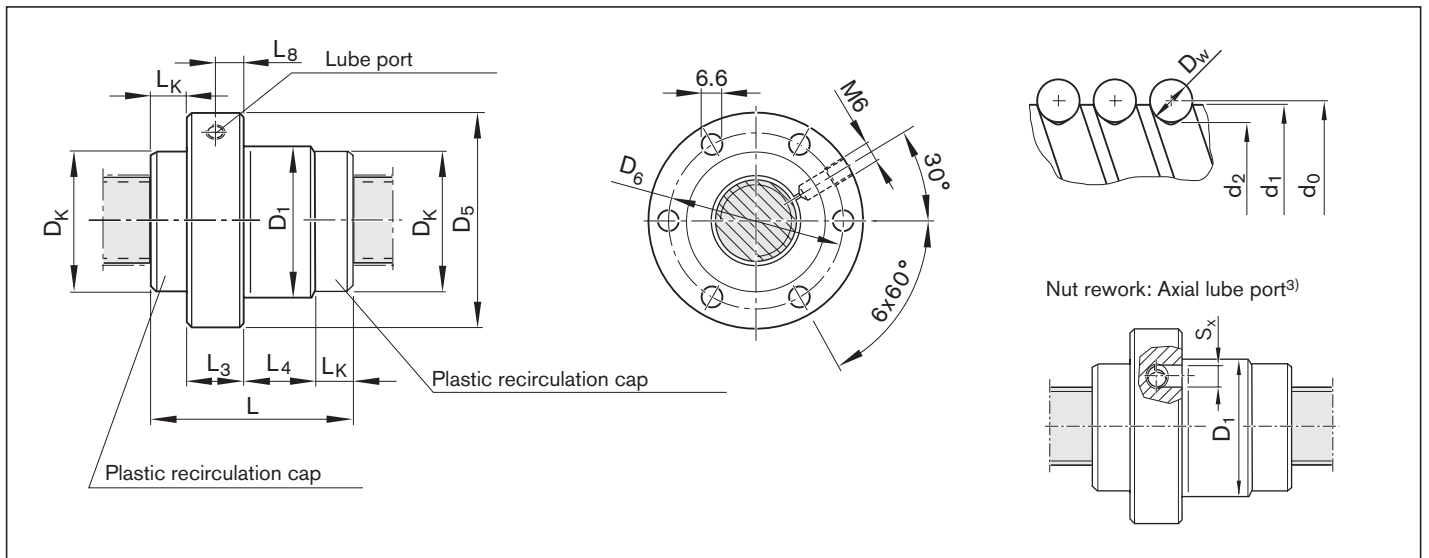

3) The axial lube port S_x is always located on the pitch circle D_6 of the nut unit.

Size $d_0 \times P \times D_w - i$	(mm)												Mass m (kg)
	d_1	d_2	D_1 g6	D_5	D_6	D_K	L ± 0.5	L_3	L_4	L_8	L_K	S_x	
20 x 40R x 3.5 - 4	19	16.4	38	63	50	37.5	57	12	23	8.0	11	4	0.51
25 x 25R x 3.5 - 4.8	24	21.4	48	73	60	40.0	52	12	14	5.0	13	4	0.51
32 x 32R x 3.969 - 4.8	31	27.9	56	80	68	50.0	68	15	21	7.7	16	4	0.78
32 x 64R x 3.969 - 4	31	27.9	56	80	68	50.0	88	15	45	7.5	14	4	1.06

Nuts, standard series

Standard series ball screw assemblies

are available with nominal diameters of 16 – 80 mm, and leads of 5 – 40 mm.
The nut types are flange, cylindrical and adjustable-preload single nuts, double nuts with flange, as well as screw-in nuts.

Benefits

- High axial load-bearing capacity
- High dynamics
- High rigidity
- Low friction
- Available from stock in many versions and sizes
- Nut housing with reference edge (both sides)

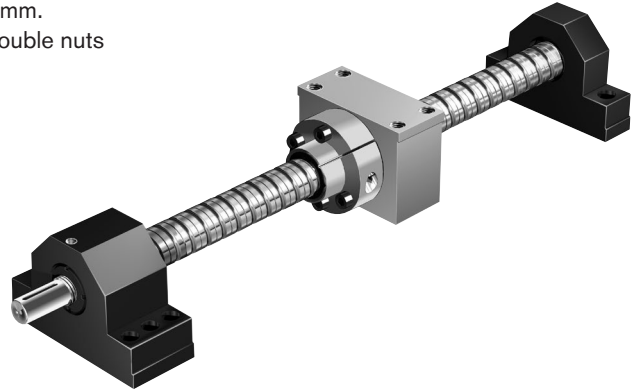

Preload classes

Option	Preload class	Definition
0	C0	Standard backlash
1	C00	Reduced backlash
2	C3	High preload (single nut)
3	C1	Moderate preload (single nut)
4	C4	High preload (double nut)
5	C5	Average preload (double nut)
6	C2	Average preload (single nut)

See nut versions for allocation of the preload classes

Overview of formats

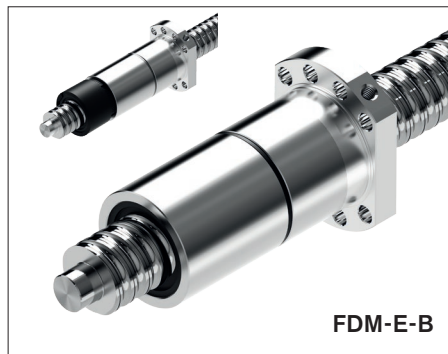
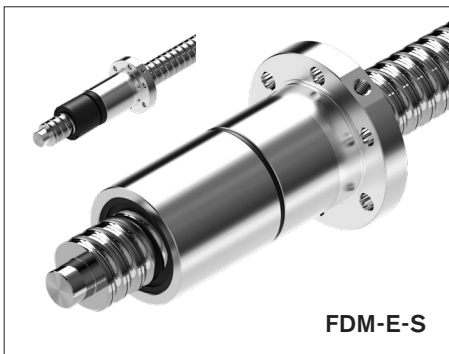
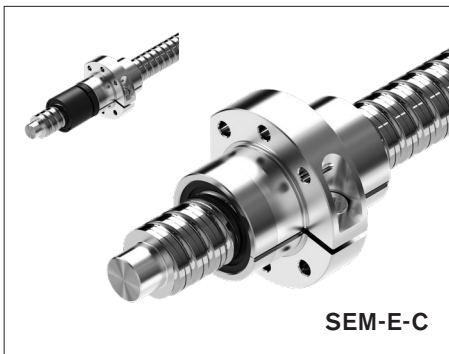
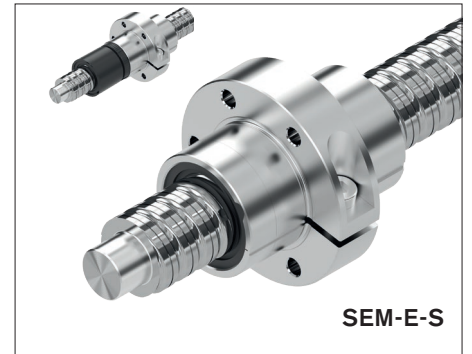
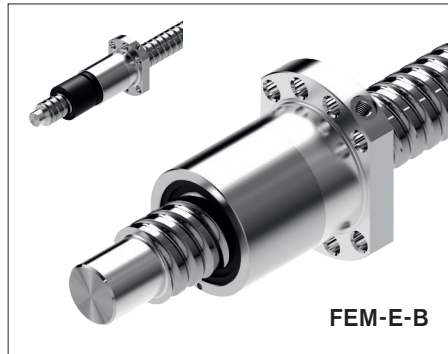
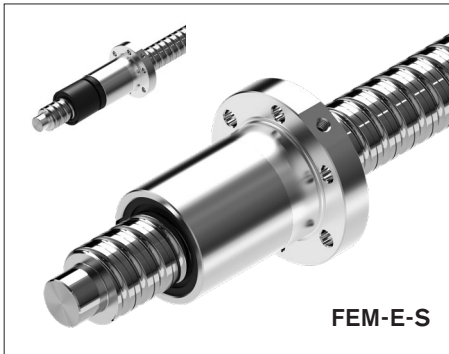

Single nut with flange FEM-E-S

Rexroth connection dimensions

With seals

Left-hand version in some cases

Preload class: C0, C00, C1, C2, C3

Tolerance grade: T3²⁾, T5, T7, T9

Note: The front lube unit is only available for the right-hand version.

⚠ When setting up applications, do not allow components to collide with the front lube unit.



Ordering data:

BASA	20 x 5R x 3	FEM-E-S - 4	00	1	2	T7	R	82Z120	41Z120	1250	0	1
------	-------------	-------------	----	---	---	----	---	--------	--------	------	---	---

d_0 = nominal diameter

P = lead (R = right-hand, L = left-hand)

D_w = ball diameter

i = number of ball track turns

Category	Size $d_0 \times P \times D_w - i$	Part number	Load ratings ³⁾		Linear speed ¹⁾ v_{max} (m/min)
			dyn. C (N)	stat. C ₀ (N)	
A	16 x 5R x 3 - 4	R1512 010 23	14,800	16,100	30
A	16 x 10R x 3 - 3	R1512 040 13	11,500	12,300	60
A	16 x 16R x 3 - 2	R1512 060 13	7,560	7,600	96
A	20 x 5R x 3 - 4	R1512 110 13	17,200	21,500	30
A	20 x 10R x 3 - 4	R1512 140 13	16,900	21,300	60
A	20 x 20R x 3.5 - 2	R1512 170 13	10,900	12,100	120
A	25 x 5R x 3 - 4	R1512 210 13	19,100	27,200	30
A	25 x 10R x 3 - 4	R1512 240 13	18,800	27,000	60
A	25 x 25R x 3.5 - 2	R1512 280 13	12,100	15,100	150
A	32 x 5R x 3.5 - 4	R1512 310 13	25,900	40,000	23
A	32 x 10R x 3.969 - 5	R1512 340 13	38,000	58,300	47
A	32 x 20R x 3.969 - 2	R1512 370 13	16,200	21,800	94
A	32 x 32R x 3.969 - 2	R1512 390 13	16,100	22,000	150
A	40 x 5R x 3.5 - 5	R1512 410 13	34,900	64,100	19
A	40 x 10R x 6 - 4	R1512 440 13	60,000	86,400	38
A	40 x 10R x 6 - 6	R1512 440 23	86,500	132,200	38
A	40 x 20R x 6 - 3	R1512 470 13	45,500	62,800	75
A	40 x 40R x 6 - 2	R1512 490 13	30,600	40,300	150
A	50 x 5R x 3.5 - 5	R1512 510 13	38,400	81,300	15
A	50 x 10R x 6 - 6	R1512 540 13	95,600	166,500	30
B	50 x 16R x 6 - 6	R1512 560 13	95,300	166,000	48
A	50 x 20R x 6.5 - 3	R1512 570 13	57,500	87,900	60
A	50 x 40R x 6.5 - 2	R1512 590 13	38,500	55,800	120
A	63 x 10R x 6 - 6	R1512 640 13	106,600	214,300	24
B	63 x 20R x 6.5 - 3	R1512 670 13	63,800	112,100	48
B	63 x 40R x 6.5 - 2	R1512 690 13	44,300	74,300	95
A	80 x 10R x 6.5 - 6	R1512 740 13	130,100	291,700	19
A	80 x 20R x 12.7 - 6	R1512 770 23	315,200	534,200	30
Versions with left-hand lead					
B	16 x 5L x 3 - 4	R1552 010 03	14,800	16,100	30
B	20 x 5L x 3 - 4	R1552 110 13	17,200	21,500	30
B	25 x 5L x 3 - 4	R1552 210 13	19,100	27,200	30
B	32 x 5L x 3.5 - 4	R1552 310 03	25,900	40,000	23
B	40 x 5L x 3.5 - 5	R1552 410 03	34,900	64,100	19
B	40 x 10L x 6 - 4	R1552 440 03	60,000	86,400	38

1) See "Characteristic speed $d_0 \cdot n$ " on page 133 and "Critical speed n_{cr} " on page 174

2) Tolerance grade T3 for sizes shown in table page 12

3) The load ratings are valid for tolerance grade T3 and T5 only.

For other tolerance grades, please take into account the correction factor f_{ac} on page 133.

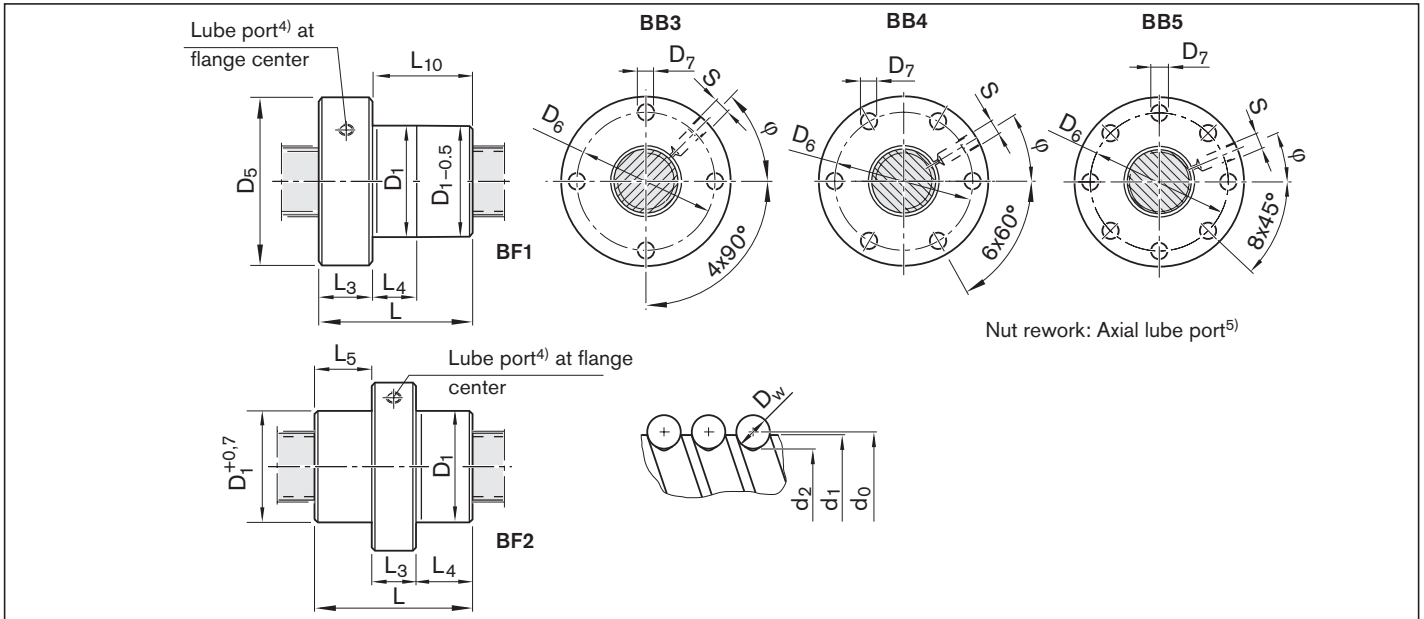

- 4) Lube port machining: flat surface $L_3 \leq 15$ mm, countersink $L_3 > 15$ mm;
5) The axial lube port S_x is always located on the pitch circle D_6 of the nut unit.

Size	(mm)																Mass
$d_0 \times P \times D_w - i$	d_1	d_2	D_1 g6	D_5	Hole pattern	D_6	D_7	Design style	L	L_3	L_4	L_5	L_{10}	$S^4)$	S_x	φ (°)	m (kg)
16 x 5R x 3 - 4	15.0	12.9	28	53	BB3	40	6.6	BF1	38	12	10.0	-	26	M6	4	315.0	0.24
16 x 10R x 3 - 3	15.0	12.9	28	53	BB3	40	6.6	BF1	45	12	16.0	-	33	M6	4	315.0	0.25
16 x 16R x 3 - 2	15.0	12.9	33	58	BB4	45	6.6	BF2	45	15	15.0	15.0	-	M6	4	30.0	0.39
20 x 5R x 3 - 4	19.0	16.9	33	58	BB4	45	6.6	BF1	40	12	10.0	-	28	M6	4	30.0	0.28
20 x 10R x 3 - 4	19.0	16.9	33	58	BB4	45	6.6	BF1	60	12	16.0	-	48	M6	4	30.0	0.36
20 x 20R x 3.5 - 2	19.0	16.7	38	63	BB4	50	6.6	BF2	57	20	18.5	18.5	-	M6	4	30.0	0.60
25 x 5R x 3 - 4	24.0	21.9	38	63	BB4	50	6.6	BF1	45	12	10.0	-	33	M6	4	30.0	0.35
25 x 10R x 3 - 4	24.0	21.9	38	63	BB4	50	6.6	BF1	64	12	16.0	-	52	M6	4	30.0	0.44
25 x 25R x 3.5 - 2	24.0	21.4	48	73	BB4	60	6.6	BF2	70	25	22.5	22.5	-	M6	4	18.0	1.09
32 x 5R x 3.5 - 4	31.0	28.4	48	73	BB4	60	6.6	BF1	48	13	10.0	-	35	M6	4	30.0	0.54
32 x 10R x 3.969 - 5	31.0	27.9	48	73	BB4	60	6.6	BF1	77	13	16.0	-	64	M6	4	30.0	0.72
32 x 20R x 3.969 - 2	31.0	27.9	56	80	BB4	68	6.6	BF1	64	15	25.0	-	49	M6	4	30.0	1.02
32 x 32R x 3.969 - 2	31.0	27.9	56	80	BB4	68	6.6	BF2	88	20	34.0	34.0	-	M6	4	30.0	1.40
40 x 5R x 3.5 - 5	39.0	36.4	56	80	BB4	68	6.6	BF1	54	15	10.0	-	39	M8x1	5	30.0	0.71
40 x 10R x 6 - 4	38.0	33.8	63	95	BB4	78	9.0	BF1	70	15	16.0	-	55	M8x1	5	30.0	1.29
40 x 10R x 6 - 6	38.0	33.8	63	95	BB4	78	9.0	BF1	90	15	16.0	-	75	M8x1	5	30.0	1.59
40 x 20R x 6 - 3	38.0	33.8	63	95	BB4	78	9.0	BF1	88	15	25.0	-	73	M8x1	5	30.0	1.54
40 x 40R x 6 - 2	38.0	33.8	72	110	BB4	90	11.0	BF2	102	40	31.0	31.0	-	M8x1	5	19.0	3.59
50 x 5R x 3.5 - 5	49.0	46.4	68	98	BB4	82	9.0	BF1	54	15	10.0	-	39	M8x1	5	30.0	1.02
50 x 10R x 6 - 6	48.0	43.8	72	110	BB4	90	11.0	BF1	90	18	16.0	-	72	M8x1	5	30.0	2.02
50 x 16R x 6 - 6	48.0	43.8	72	110	BB4	90	11.0	BF1	128	18	25.0	-	110	M8x1	5	30.0	2.58
50 x 20R x 6.5 - 3	48.0	43.4	85	125	BB4	105	11.0	BF1	92	22	25.0	-	70	M8x1	5	30.0	3.40
50 x 40R x 6.5 - 2	48.0	43.4	85	125	BB4	105	11.0	BF1	109	22	45.0	-	87	M8x1	5	30.0	3.87
63 x 10R x 6 - 6	61.0	56.8	85	125	BB4	105	11.0	BF1	90	22	16.0	-	68	M8x1	5	30.0	2.62
63 x 20R x 6.5 - 3	61.0	56.4	95	140	BB4	118	14.0	BF1	92	22	25.0	-	70	M8x1	5	30.0	3.71
63 x 40R x 6.5 - 2	61.0	56.4	95	140	BB4	118	14.0	BF1	109	22	45.0	-	87	M8x1	5	30.0	4.21
80 x 10R x 6.5 - 6	78.0	73.3	105	150	BB4	125	14.0	BF1	95	22	16.0	-	73	M8x1	5	30.0	3.78
80 x 20R x 12.7 - 6	76.0	67.0	125	180	BB5	152	18.0	BF1	170	25	25.0	-	145	M8x1	5	22.5	11.00
Versions with left-hand lead																	
16 x 5L x 3 - 4	15.0	12.9	28	53	BB3	40	6.6	BF1	38	12	10.0	-	26	M6	4	45.0	0.24
20 x 5L x 3 - 4	19.0	16.9	33	58	BB4	45	6.6	BF1	40	12	10.0	-	28	M6	4	30.0	0.28
25 x 5L x 3 - 4	24.0	21.9	38	63	BB4	50	6.6	BF1	45	12	10.0	-	33	M6	4	30.0	0.35
32 x 5L x 3.5 - 4	31.0	28.4	48	73	BB4	60	6.6	BF1	48	13	10.0	-	35	M6	4	30.0	0.54
40 x 5L x 3.5 - 5	39.0	36.4	56	80	BB4	68	6.6	BF1	54	15	10.0	-	39	M8x1	5	30.0	0.71
40 x 10L x 6 - 4	38.0	33.8	63	95	BB4	78	9.0	BF1	70	15	16.0	-	55	M8x1	5	30.0	1.29

Single nut with flange FEM-E-B

Mounting dimensions similar to
DIN 69051, Part 5
Flange type B

With seals
With left-hand version in some cases
Preload class: C0, C00, C1, C2, C3
Tolerance grade: T3²⁾, T5, T7, T9

Note: The front lube unit is only available
for the right-hand version.

▲ When setting up applications, do not
allow components to collide with the
front lube unit.

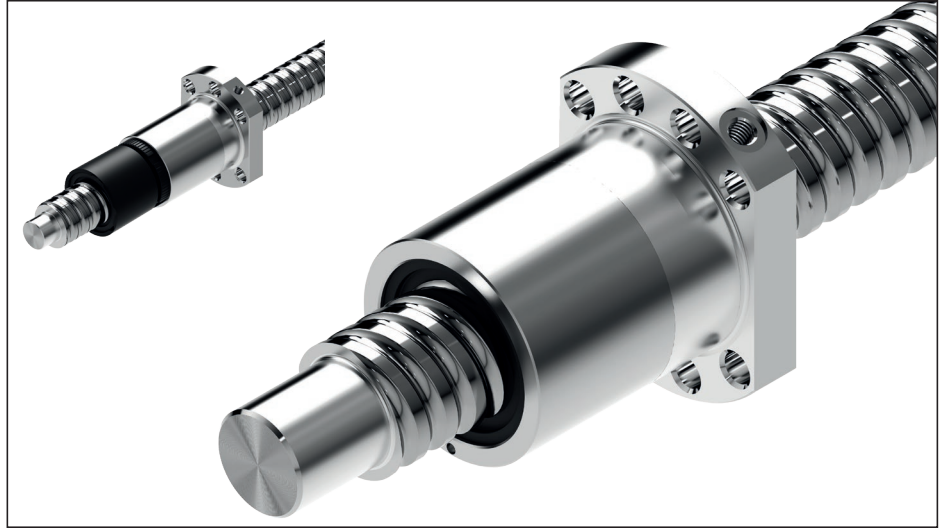

Ordering data:

BASA	20 x 5R x 3	FEM-E-B - 4	00	1	2	T7	R	82Z120	41Z120	1250	0	1
------	-------------	-------------	----	---	---	----	---	--------	--------	------	---	---

d_0 = nominal diameter
 P = lead (R = right-hand, L = left-hand)
 D_w = ball diameter
 i = number of ball track turns

Category	Size $d_0 \times P \times D_w - i$	Part number	Load ratings ³⁾		Linear speed ¹⁾ v_{max} (m/min)
			dyn. C (N)	stat. C ₀ (N)	
A	16 x 5R x 3 - 4	R1502 010 63	14,800	16,100	30
A	16 x 10R x 3 - 3	R1502 040 83	11,500	12,300	60
A	16 x 16R x 3 - 3	R1502 060 63	11,200	12,000	96
A	20 x 5R x 3 - 4	R1502 110 83	17,200	21,500	30
A	20 x 10R x 3 - 4	R1502 140 63	16,900	21,300	60
A	20 x 20R x 3.5 - 3	R1502 170 63	16,000	18,800	120
A	25 x 5R x 3 - 4	R1502 210 83	19,100	27,200	30
A	25 x 10R x 3 - 4	R1502 240 83	18,800	27,000	60
A	25 x 25R x 3.5 - 3	R1502 280 63	17,600	23,300	150
A	32 x 5R x 3.5 - 4	R1502 310 83	25,900	40,000	23
A	32 x 10R x 3.969 - 5	R1502 340 84	38,000	58,300	47
A	32 x 20R x 3.969 - 3	R1502 370 63	23,600	33,700	94
A	32 x 32R x 3.969 - 3	R1502 390 63	23,400	34,000	150
A	40 x 5R x 3.5 - 5	R1502 410 84	34,900	64,100	19
A	40 x 10R x 6 - 4	R1502 440 83	60,000	86,400	38
A	40 x 10R x 6 - 6	R1502 440 84	86,500	132,200	38
A	40 x 12R x 6 - 4	R1502 450 63	59,900	86,200	45
A	40 x 16R x 6 - 4	R1502 460 63	59,600	85,900	60
A	40 x 20R x 6 - 3	R1502 470 83	45,500	62,800	75
B	40 x 25R x 6 - 4	R1502 480 83	56,900	85,800	93
B	40 x 30R x 6 - 4	R1502 4A0 83	56,300	85,100	112
A	40 x 40R x 6 - 3	R1502 490 63	44,400	62,300	150
A	50 x 5R x 3.5 - 5	R1502 510 84	38,400	81,300	15
A	50 x 10R x 6 - 6	R1502 540 84	95,600	166,500	30
A	50 x 12R x 6 - 6	R1502 550 64	95,500	166,400	36
A	50 x 16R x 6 - 6	R1502 560 64	95,300	166,000	48
A	50 x 20R x 6.5 - 5	R1502 570 84	90,800	149,700	60
B	50 x 25R x 6.5 - 4	R1502 580 84	71 800	149 700	75
B	50 x 30R x 6.5 - 4	R1502 5A0 83	71,300	118,800	90
A	50 x 40R x 6.5 - 3	R1502 590 63	55,800	85,900	120
A	63 x 10R x 6 - 6	R1502 640 84	106,600	214,300	24
A	63 x 20R x 6.5 - 5	R1502 670 84	100,700	190,300	48
A	63 x 40R x 6.5 - 3	R1502 690 63	64,100	114,100	95
A	80 x 10R x 6.5 - 6	R1502 740 84	130,100	291,700	19
A	80 x 20R x 12.7 - 6	R1502 770 94	315,200	534,200	30
B	80 x 40R x 12.7 - 4	R1502 790 94	216,600	367,600	60
Versions with left-hand lead					
B	16 x 5L x 3 - 4	R1552 010 63	14,800	16,100	30
A	20 x 5L x 3 - 4	R1552 110 83	17,200	21,500	30
B	25 x 5L x 3 - 4	R1552 210 83	19,100	27,200	30
B	32 x 5L x 3.5 - 4	R1552 310 63	25,900	40,000	23
B	40 x 5L x 3.5 - 5	R1552 410 64	34,900	64,100	19
B	40 x 10L x 6 - 4	R1552 440 63	60,000	86,400	38

- See "Characteristic speed $d_0 \cdot n$ " on page 133 and "Critical speed n_{cr} " on page 174
- Tolerance grade T3 for sizes shown in table page 12
- The load ratings are valid for tolerance grade T3 and T5 only.
For other tolerance grades, please take into account the correction factor f_{ac} on page 133.
- Lube port machining: flat surface $L_3 \leq 15$ mm, countersink $L_3 > 15$ mm;
- With left-hand lead the lube port position mirrors its position with right-hand lead!
- The axial lube port S_x is always located on the pitch circle D_6 of the nut unit.

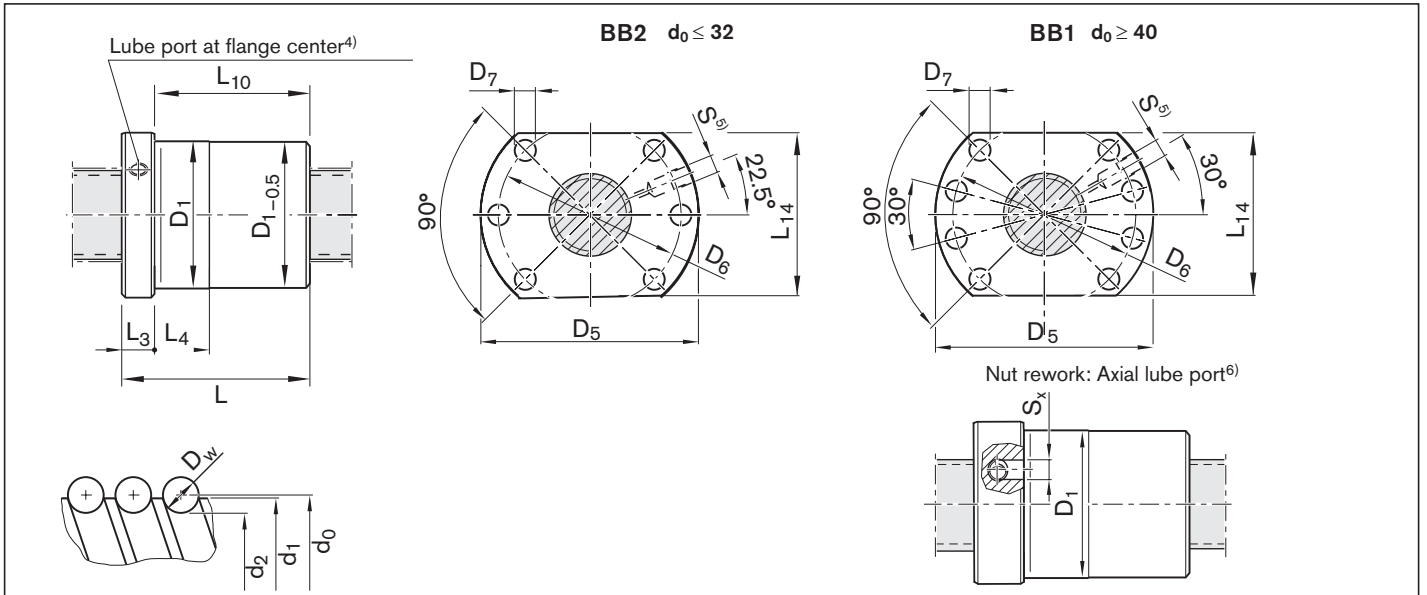

Size $d_0 \times P \times D_w - i$	(mm)														Mass	
	d_1	d_2	D_1 g6	D_5	Hole pattern	D_6	D_7	L	L_3	L_4	L_{10}	L_{14}	$S^4)$	S_x	m (kg)	
16 x 5R x 3 - 4	15	12.9	28	48	BB2	38	5.5	38	12	10	26	40.0	M6	4	0.19	
16 x 10R x 3 - 3	15	12.9	28	48	BB2	38	5.5	45	12	16	33	40.0	M6	4	0.21	
16 x 16R x 3 - 3	15	12.9	28	48	BB2	38	5.5	61	12	20	49	40.0	M6	4	0.26	
20 x 5R x 3 - 4	19	16.9	36	58	BB2	47	6.6	40	12	10	28	44.0	M6	4	0.31	
20 x 10R x 3 - 4	19	16.9	36	58	BB2	47	6.6	60	12	16	48	44.0	M6	4	0.40	
20 x 20R x 3.5 - 3	19	16.7	36	58	BB2	47	6.6	77	12	25	65	44.0	M6	4	0.49	
25 x 5R x 3 - 4	24	21.9	40	62	BB2	51	6.6	45	12	10	33	48.0	M6	4	0.36	
25 x 10R x 3 - 4	24	21.9	40	62	BB2	51	6.6	64	12	16	52	48.0	M6	4	0.47	
25 x 25R x 3.5 - 3	24	21.4	40	62	BB2	51	6.6	95	12	30	83	48.0	M6	4	0.63	
32 x 5R x 3.5 - 4	31	28.4	50	80	BB2	65	9.0	48	13	10	35	62.0	M6	4	0.62	
32 x 10R x 3.969 - 5	31	27.9	50	80	BB2	65	9.0	77	13	16	64	62.0	M6	4	0.84	
32 x 20R x 3.969 - 3	31	27.9	50	80	BB2	65	9.0	84	13	25	71	62.0	M6	4	0.90	
32 x 32R x 3.969 - 3	31	27.9	50	80	BB2	65	9.0	120	13	40	107	62.0	M6	4	1.21	
40 x 5R x 3.5 - 5	39	36.4	63	93	BB1	78	9.0	54	15	10	39	70.0	M8x1	5	1.03	
40 x 10R x 6 - 4	38	33.8	63	93	BB1	78	9.0	70	15	16	55	70.0	M8x1	5	1.19	
40 x 10R x 6 - 6	38	33.8	63	93	BB1	78	9.0	90	15	16	75	70.0	M8x1	5	1.49	
40 x 12R x 6 - 4	38	33.8	63	93	BB1	78	9.0	75	15	25	60	70.0	M8x1	5	1.27	
40 x 16R x 6 - 4	38	33.8	63	93	BB1	78	9.0	90	15	25	75	70.0	M8x1	5	1.51	
40 x 20R x 6 - 3	38	33.8	63	93	BB1	78	9.0	88	15	25	73	70.0	M8x1	5	1.44	
40 x 25R x 6 - 4	38	33.8	63	93	BB1	78	9.0	127	15	30	112	70.0	M8x1	5	1.91	
40 x 30R x 6 - 4	38	33.8	63	93	BB1	78	9.0	145	15	35	130	70.0	M8x1	5	2.21	
40 x 40R x 6 - 4	38	33.8	63	93	BB1	78	9.0	142	15	45	127	70.0	M8x1	5	2.16	
50 x 5R x 3.5 - 5	49	46.4	75	110	BB1	93	11.0	54	15	10	39	85.0	M8x1	5	1.39	
50 x 10R x 6 - 6	48	43.8	75	110	BB1	93	11.0	90	18	16	72	85.0	M8x1	5	2.14	
50 x 12R x 6 - 6	48	43.8	75	110	BB1	93	11.0	105	18	25	87	85.0	M8x1	5	2.38	
50 x 16R x 6 - 6	48	43.8	75	110	BB1	93	11.0	128	18	25	110	85.0	M8x1	5	2.75	
50 x 20R x 6.5 - 5	48	43.4	75	110	BB1	93	11.0	132	18	25	114	85.0	M8x1	5	2.73	
50 x 25R x 6.5 - 4	48	43.4	75	110	BB1	93	11.0	132	18	25	114	85.0	M8x1	-	2.78	
50 x 30R x 6.5 - 4	48	43.4	75	110	BB1	93	11.0	151	18	35	133	85.0	M8x1	5	3.12	
50 x 40R x 6.5 - 3	48	43.4	75	110	BB1	93	11.0	149	18	45	131	85.0	M8x1	5	3.04	
63 x 10R x 6 - 6	61	56.8	90	125	BB1	108	11.0	90	22	16	68	95.0	M8x1	5	2.56	
63 x 20R x 6.5 - 5	61	56.4	95	135	BB1	115	13.5	132	22	25	110	100.0	M8x1	5	4.51	
63 x 40R x 6.5 - 3	61	56.4	95	135	BB1	115	13.5	149	22	45	127	100.0	M8x1	5	5.04	
80 x 10R x 6.5 - 6	78	73.3	105	145	BB1	125	13.5	95	22	16	73	110.0	M8x1	5	3.40	
80 x 20R x 12.7 - 6	76	67.0	125	165	BB1	145	13.5	170	25	25	145	130.0	M8x1	5	10.20	
80 x 40R x 12.7 - 4	76	67.0	125	165	BB1	145	13.5	206	25	25	181	130.0	M8x1	5	11.60	
Versions with left-hand lead																
16 x 5L x 3 - 4	15	12.9	28	48	BB2	38	5.5	38	12	10	26	40.0	M6	4	0.19	
20 x 5L x 3 - 4	19	16.9	36	58	BB2	47	6.6	40	12	10	28	44.0	M6	4	0.31	
25 x 5L x 3 - 4	24	21.9	40	62	BB2	51	6.6	45	12	10	33	48.0	M6	4	0.36	
32 x 5L x 3.5 - 4	31	28.4	50	80	BB2	65	9.0	48	13	10	35	62.0	M6	4	0.62	
40 x 5L x 3.5 - 5	39	36.4	63	93	BB1	78	9.0	54	15	10	39	70.0	M8x1	5	1.03	
40 x 10L x 6 - 4	38	33.8	63	93	BB1	78	9.0	70	15	16	55	70.0	M8x1	5	1.19	

Adjustable-preload single nut SEM-E-S

Rexroth connection dimensions

With seals
Left-hand version in some cases
Preload adjustable
Tolerance grade T3², T5, T7

Note: The front lube unit is only available for the right-hand version.

⚠ When setting up applications, do not allow components to collide with the front lube unit.

d_0 = nominal diameter
 P = lead (R = right-hand, L = left-hand)
 D_w = ball diameter
 i = number of ball track turns



Ordering data:

BASA	20 x 5R x 3	SEM-E-S - 4	00	1	2	T7	R	82Z120	41Z120	1250	0	1
------	-------------	-------------	----	---	---	----	---	--------	--------	------	---	---

Category	Size $d_0 \times P \times D_w - i$	Part number	Load ratings ³⁾		Linear speed ¹⁾ v_{max} (m/min)	Centering diameter D_1 after adjustment	
			dyn. C (N)	stat. C_0 (N)		min. (mm)	max. (mm)
A	16 x 5R x 3 - 4	R1512 010 24	14,800	16,100	30	27.940	27.975
B	16 x 10R x 3 - 3	R1512 040 14	11,500	12,300	60	27.940	27.975
B	16 x 16R x 3 - 2	R1512 060 14	7,560	7,600	96	32.945	32.973
A	20 x 5R x 3 - 4	R1512 110 14	17,200	21,500	30	32.935	32.970
A	20 x 20R x 3.5 - 2	R1512 170 14	10,900	12,100	120	37.945	37.973
A	25 x 5R x 3 - 4	R1512 210 14	19,100	27,200	30	37.935	37.970
A	25 x 10R x 3 - 4	R1512 240 14	18,800	27,000	60	37.935	37.970
A	25 x 25R x 3.5 - 2	R1512 280 14	12,100	15,100	150	47.945	47.973
A	32 x 5R x 3.5 - 4	R1512 310 14	25,900	40,000	23	47.935	47.970
A	32 x 10R x 3.969 - 5	R1512 340 14	38,000	58,300	47	47.935	47.970
A	32 x 20R x 3.969 - 2	R1512 370 14	16,200	21,800	94	55.941	55.969
A	32 x 32R x 3.969 - 2	R1512 390 14	16,100	22,000	150	55.941	55.969
A	40 x 5R x 3.5 - 5	R1512 410 14	34,900	64,100	19	55.931	55.966
A	40 x 10R x 6 - 4	R1512 440 14	60,000	86,400	38	62.931	62.966
A	40 x 20R x 6 - 3	R1512 470 14	45,500	62,800	75	62.941	62.969
A	40 x 40R x 6 - 2	R1512 490 14	30,600	40,300	150	71.941	71.969
B	50 x 5R x 3.5 - 5	R1512 510 14	38,400	81,300	15	67.931	67.966
A	50 x 10R x 6 - 6	R1512 540 14	95,600	166,500	30	71.931	71.966
B	50 x 20R x 6.5 - 3	R1512 570 14	57,500	87,900	60	84.936	84.964
B	50 x 40R x 6.5 - 2	R1512 590 14	38,500	55,800	120	84.936	84.964
A	63 x 10R x 6 - 6	R1512 640 14	106,600	214,300	24	84.926	84.961
B	63 x 20R x 6.5 - 3	R1512 670 14	63,800	112,100	48	94.936	94.964
B	63 x 40R x 6.5 - 2	R1512 690 14	44,300	74,300	95	94.936	94.964
B	80 x 10R x 6.5 - 6	R1512 740 14	130,100	291,700	19	104.926	104.961
B	80 x 20R x 12.7 - 6	R1512 770 24	315,200	534,200	30	124.931	124.959
Versions with left-hand lead							
B	16 x 5L x 3 - 4	R1552 010 04	14,800	16,100	30	27.94	27.975
B	20 x 5L x 3 - 4	R1552 110 14	17,200	21,500	30	32.935	32.970
B	25 x 5L x 3 - 4	R1552 210 14	19,100	27,200	30	37.935	37.970
A	32 x 5L x 3.5 - 4	R1552 310 04	25,900	40,000	23	47.935	47.970
B	40 x 5L x 3.5 - 5	R1552 410 04	34,900	64,100	19	55.931	55.966
A	40 x 10L x 6 - 4	R1552 440 04	60,000	86,400	38	62.931	62.966

1) See "Characteristic speed $d_0 \cdot n$ " on page 133 and "Critical speed n_{cr} " on page 174

2) Tolerance grade T3 for sizes shown in table page 12

3) The load ratings are valid for tolerance grade T3 and T5 only.

For other tolerance grades, please take into account the correction factor f_{ac} on page 133.

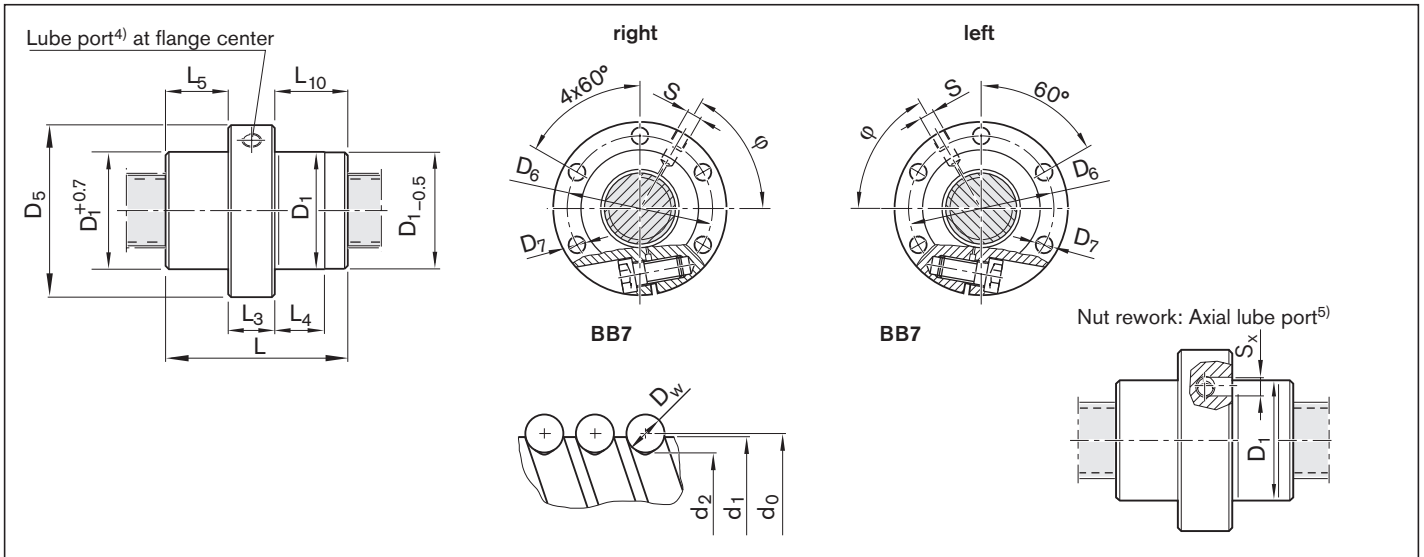

- 4) Lube port machining: flat surface $L_3 \leq 15$ mm, countersink $L_3 > 15$ mm. For size 8 x 2.5, a funnel-type lube nipple DIN 3405 is provided.
5) The axial lube port S_x is always located on the pitch circle D_6 of the nut unit.

Size	(mm)															φ	Mass m (kg)
	d_1	d_2	D_1 f9	D_5	Hole pattern	D_6	D_7	L	L_3	L_4	L_5	L_{10}	S^4	S_x			
$d_0 \times P \times D_w - i$																	
16 x 5R x 3 - 4	15.0	12.9	28	53	BB7	40	6.6	38	15	10.0	11.5	11.5	M6	4	53	0.24	
16 x 10R x 3 - 3	15.0	12.9	28	53	BB7	40	6.6	45	15	15.0	15.0	15.0	M6	4	180	0.25	
16 x 16R x 3 - 2	15.0	12.9	33	58	BB7	45	6.6	45	15	15.0	15.0	15.0	M6	4	50	0.42	
20 x 5R x 3 - 4	19.0	16.9	33	58	BB7	45	6.6	40	15	10.0	12.5	12.5	M6	4	56	0.31	
20 x 20R x 3.5 - 2	19.0	16.7	38	63	BB7	50	6.6	57	20	18.5	18.5	18.5	M6	4	60	0.63	
25 x 5R x 3 - 4	24.0	21.9	38	63	BB7	50	6.6	45	20	10.0	12.5	12.5	M6	4	60	0.44	
25 x 10R x 3 - 4	24.0	21.9	38	63	BB7	50	6.6	64	20	16.0	22.0	22.0	M6	4	60	0.53	
25 x 25R x 3.5 - 2	24.0	21.4	48	73	BB7	60	6.6	70	25	22.5	22.5	22.5	M6	4	48	1.13	
32 x 5R x 3.5 - 4	31.0	28.4	48	73	BB7	60	6.6	48	20	10.0	14.0	14.0	M6	4	60	0.64	
32 x 10R x 3.969 - 5	31.0	27.9	48	73	BB7	60	6.6	77	20	16.0	28.5	28.5	M6	4	168	0.87	
32 x 20R x 3.969 - 2	31.0	27.9	56	80	BB7	68	6.6	64	20	22.0	22.0	22.0	M6	4	60	1.14	
32 x 32R x 3.969 - 2	31.0	27.9	56	80	BB7	68	6.6	88	20	34.0	34.0	34.0	M6	4	60	1.44	
40 x 5R x 3.5 - 5	39.0	36.4	56	80	BB7	68	6.6	54	20	10.0	17.0	17.0	M8x1	5	65	0.87	
40 x 10R x 6 - 4	38.0	33.8	63	95	BB7	78	9.0	70	25	16.0	22.5	22.5	M8x1	5	57	1.53	
40 x 20R x 6 - 3	38.0	33.8	63	95	BB7	78	9.0	88	25	25.0	31.5	31.5	M8x1	5	180	1.77	
40 x 40R x 6 - 2	38.0	33.8	72	110	BB7	90	11.0	102	40	31.0	31.0	31.0	M8x1	5	49	3.77	
50 x 5R x 3.5 - 5	49.0	46.4	68	98	BB7	82	9.0	54	25	10.0	14.5	14.5	M8x1	5	67	1.23	
50 x 10R x 6 - 6	48.0	43.8	72	110	BB7	90	11.0	90	30	16.0	30.0	30.0	M8x1	5	61	2.44	
50 x 20R x 6.5 - 3	48.0	43.3	85	125	BB7	105	11.0	92	30	25.0	31.0	31.0	M8x1	5	180	3.94	
50 x 40R x 6.5 - 2	48.0	43.3	85	125	BB7	105	11.0	109	30	39.5	39.5	39.5	M8x1	5	60	4.42	
63 x 10R x 6 - 6	61.0	56.8	85	125	BB7	105	11.0	90	30	16.0	30.0	30.0	M8x1	5	65	2.94	
63 x 20R x 6.5 - 3	61.0	56.3	95	140	BB7	118	14.0	92	30	25.0	31.0	31.0	M8x1	5	190	4.45	
63 x 40R x 6.5 - 2	61.0	56.3	95	140	BB7	118	14.0	109	30	39.5	39.5	39.5	M8x1	5	70	4.95	
80 x 10R x 6.5 - 6	78.0	73.3	105	150	BB7	125	14.0	95	30	16.0	32.5	32.5	M8x1	5	67	4.20	
80 x 20R x 12.7 - 6	76.0	67.0	125	180	BB7	152	18.0	170	50	25.0	60.0	60.0	M8x1	5	60	13.3	
Versions with left-hand lead																	
16 x 5L x 3 - 4	15.0	12.9	28	53	BB7	40	6.6	38	15	10.0	11.5	11.5	M6	4	53	0.24	
20 x 5L x 3 - 4	19.0	16.9	33	58	BB7	45	6.6	40	15	10.0	12.5	12.5	M6	4	56	0.31	
25 x 5L x 3 - 4	24.0	21.9	38	63	BB7	50	6.6	45	20	10.0	12.5	12.5	M6	4	60	0.44	
32 x 5L x 3.5 - 4	31.0	28.4	48	73	BB7	60	6.6	48	20	10.0	14.0	14.0	M6	4	59	0.64	
40 x 5L x 3.5 - 5	39.0	36.4	56	80	BB7	68	6.6	54	20	10.0	17.0	17.0	M8x1	5	65	0.87	
40 x 10L x 6 - 4	38.0	33.8	63	95	BB7	78	9.0	70	25	16.0	22.5	22.5	M8x1	5	57	1.53	

Adjustable-preload single nut SEM-E-C

Mounting dimensions similar to
DIN 69051, Part 5
flange type C

With seals Adjustable preload
Tolerance grade T3², T5, T7

⚠ When setting up applications, do not
allow components to collide with the
front lube unit.

d_0 = nominal diameter
P = lead (R = right-hand)
 D_w = ball diameter
i = number of ball track turns



Ordering data:

BASA	20 x 5R x 3	SEM-E-C - 4	00	1	2	T7	R	82Z120	41Z120	1250	0	1
------	-------------	-------------	----	---	---	----	---	--------	--------	------	---	---

Category	Size $d_0 \times P \times D_w - i$	Part number	Load ratings ³⁾		Linear speed ¹⁾ v_{max} (m/min)	Centering diameter D_1 after adjustment	
			dyn. C (N)	stat. C_0 (N)		min. (mm)	max. (mm)
A	16 x 5R x 3 - 4	R1512 010 55	14,800	16,100	30	27.940	27.975
B	16 x 10R x 3 - 3	R1512 040 75	11,500	12,300	60	27.940	27.975
B	16 x 16R x 3 - 3	R1512 060 55	11,200	12,000	96	27.950	27.978
A	20 x 5R x 3 - 4	R1512 110 75	17,200	21,500	30	35.935	35.970
A	20 x 20R x 3.5 - 3	R1512 170 55	16,000	18,800	120	35.945	35.973
A	25 x 5R x 3 - 4	R1512 210 75	19,100	27,200	30	39.935	39.970
A	25 x 10R x 3 - 4	R1512 240 75	18,800	27,000	60	39.935	39.970
B	25 x 25R x 3.5 - 3	R1512 280 55	17,600	23,300	150	39.945	39.973
A	32 x 5R x 3.5 - 4	R1512 310 75	25,900	40,000	23	49.935	49.970
A	32 x 10R x 3.969 - 5	R1512 340 75	38,000	58,300	47	49.935	49.970
A	32 x 20R x 3.969 - 3	R1512 370 55	23,600	33,700	94	49.945	49.973
B	32 x 32R x 3.969 - 3	R1512 390 55	23,400	34,000	150	49.945	49.973
A	40 x 5R x 3.5 - 5	R1512 410 75	34,900	64,100	19	62.931	62.966
B	40 x 10R x 6 - 4	R1512 440 75	60,000	86,400	38	62.931	62.966
B	40 x 12R x 6 - 4	R1512 450 55	59,900	86,200	45	62.931	62.966
B	40 x 20R x 6 - 3	R1512 470 75	45,500	62,800	75	62.941	62.969
B	40 x 40R x 6 - 3	R1512 490 55	44,400	62,300	150	62.941	62.969
B	50 x 5R x 3.5 - 5	R1512 510 75	38,400	81,300	15	74.931	74.966
B	50 x 10R x 6 - 6	R1512 540 75	95,600	166,500	30	74.931	74.966
B	50 x 12R x 6 - 6	R1512 550 55	95,500	166,400	36	74.931	74.966
A	50 x 20R x 6.5 - 5	R1512 570 76	90,800	149,700	60	74.941	74.969
B	50 x 40R x 6.5 - 3	R1512 590 55	55,800	85,900	120	74.941	74.969
B	63 x 10R x 6 - 6	R1512 640 75	106,600	214,300	24	89.926	89.961
B	63 x 20R x 6.5 - 5	R1512 670 76	100,700	190,300	48	94.936	94.964
B	63 x 40R x 6.5 - 3	R1512 690 55	64,100	114,100	95	94.936	94.964
B	80 x 10R x 6.5 - 6	R1512 740 75	130,100	291,700	19	104.926	104.961
B	80 x 20R x 12.7 - 6	R1512 770 56	315,200	534,200	30	124.931	124.959

1) See "Characteristic speed $d_0 \cdot n$ " on page 133 and "Critical speed n_{cr} " on page 174

2) Tolerance grade T3 for sizes shown in table page 12

3) The load ratings are valid for tolerance grade T3 and T5 only.

For other tolerance grades, please take into account the correction factor f_{ac} on page 133.

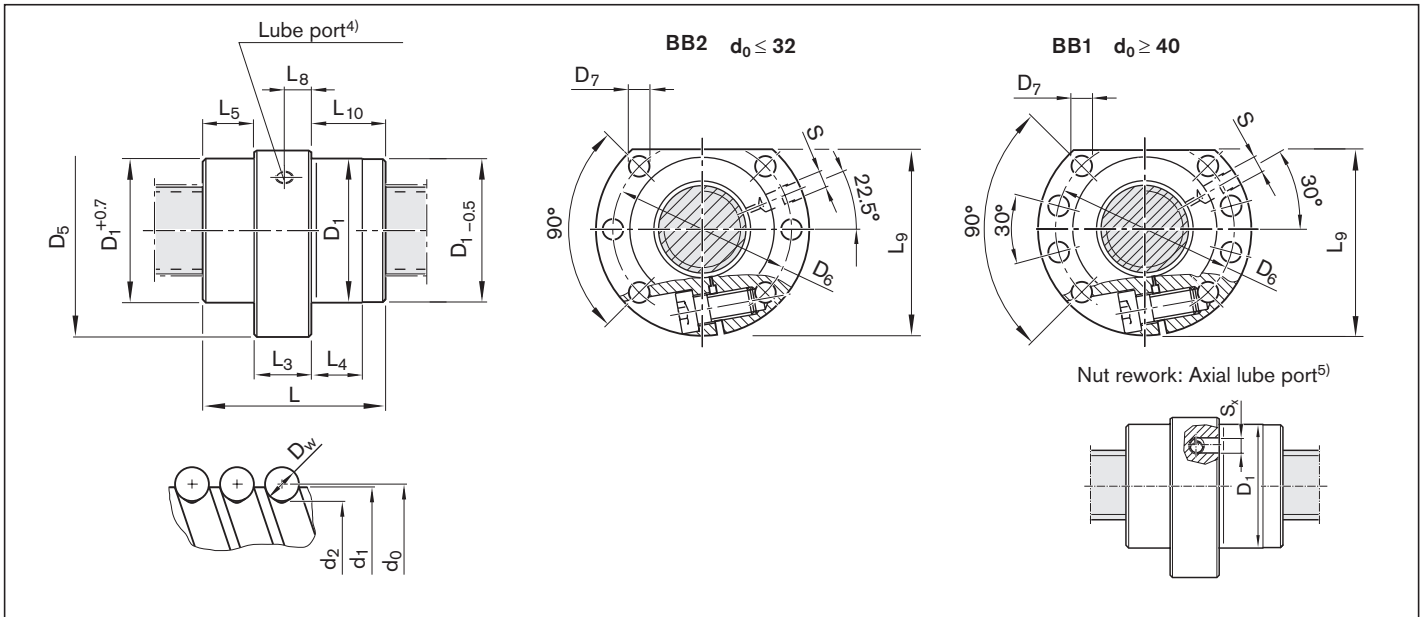

- 4) Lube port machining: flat surface $L_3 \leq 15$ mm, countersink $L_3 > 15$ mm
 5) The axial lube port S_x is always located on the pitch circle D_6 of the nut unit.

Size $d_0 \times P \times D_w - i$	(mm)																Mass m (kg)
	d_1	d_2	D_1 f9	D_5	Hole pattern	D_6	D_7	L	L_3	L_4	L_5	L_8	L_9	L_{10}	$S^4)$	S_x	
16 x 5R x 3 - 4	15.0	12.9	28	48	BB2	38	5.5	38	15	10	11.5	7.1	44.0	11.5	M6	4	0.20
16 x 10R x 3 - 3	15.0	12.9	28	48	BB2	38	5.5	45	15	15	15.0	11.0	44.0	15.0	M6	4	0.22
16 x 16R x 3 - 3	15.0	12.9	28	48	BB2	38	5.5	61	15	20	23.0	10.0	44.0	23.0	M6	4	0.29
20 x 5R x 3 - 4	19.0	16.9	36	58	BB2	47	6.6	40	15	10	12.5	7.1	51.0	12.5	M6	4	0.33
20 x 20R x 3.5 - 3	19.0	16.7	36	58	BB2	47	6.6	77	20	25	28.5	12.5	51.0	28.5	M6	4	0.56
25 x 5R x 3 - 4	24.0	21.9	40	62	BB2	51	6.6	45	20	10	12.5	9.5	55.0	12.5	M6	4	0.43
25 x 10R x 3 - 4	24.0	21.9	40	62	BB2	51	6.6	64	20	16	22.0	10.0	55.0	22.0	M6	4	0.54
25 x 25R x 3.5 - 3	24.0	21.4	40	62	BB2	51	6.6	95	25	30	35.0	14.0	55.0	35.0	M6	4	0.77
32 x 5R x 3.5 - 4	31.0	28.4	50	80	BB2	65	9.0	48	20	10	14.0	9.7	71.0	14.0	M6	4	0.74
32 x 10R x 3.969 - 5	31.0	27.9	50	80	BB2	65	9.0	77	20	16	28.5	12.5	71.0	28.5	M6	4	0.97
32 x 20R x 3.969 - 3	31.0	27.9	50	80	BB2	65	9.0	84	20	25	32.0	12.5	71.0	32.0	M6	4	1.04
32 x 32R x 3.969 - 3	31.0	27.9	50	80	BB2	65	9.0	120	20	40	50.0	12.5	71.0	50.0	M6	4	1.34
40 x 5R x 3.5 - 5	39.0	36.4	63	93	BB1	78	9.0	54	25	10	14.5	12.0	81.5	14.5	M8x1	5	1.25
40 x 10R x 6 - 4	38.0	33.8	63	93	BB1	78	9.0	70	25	16	22.5	11.8	81.5	22.5	M8x1	5	1.39
40 x 12R x 6 - 4	38.0	33.8	63	93	BB1	78	9.0	75	25	25	25.0	12.5	81.5	25.0	M8x1	5	1.47
40 x 20R x 6 - 3	38.0	33.8	63	93	BB1	78	9.0	88	25	25	31.5	16.5	81.5	31.5	M8x1	5	1.55
40 x 40R x 6 - 3	38.0	33.8	63	93	BB1	78	9.0	142	40	45	51.0	25.0	81.5	51.0	M8x1	5	2.69
50 x 5R x 3.5 - 5	49.0	46.4	75	110	BB1	93	11.0	54	25	10	14.5	12.0	97.5	14.5	M8x1	5	1.67
50 x 10R x 6 - 6	48.0	43.8	75	110	BB1	93	11.0	90	30	16	30.0	14.1	97.5	30.0	M8x1	5	2.46
50 x 12R x 6 - 6	48.0	43.8	75	110	BB1	93	11.0	105	30	25	37.5	15.0	97.5	37.5	M8x1	5	2.69
50 x 20R x 6.5 - 5	48.0	43.4	75	110	BB1	93	11.0	132	30	25	51.0	20.0	97.5	51.0	M8x1	5	3.08
50 x 40R x 6.5 - 3	48.0	43.4	75	110	BB1	93	11.0	149	30	45	59.5	18.0	97.5	59.5	M8x1	5	3.39
63 x 10R x 6 - 6	61.0	56.8	90	125	BB1	108	11.0	90	30	16	30.0	14.0	110.0	30.0	M8x1	5	2.83
63 x 20R x 6.5 - 5	61.0	56.4	95	135	BB1	115	13.5	132	30	25	51.0	20.0	117.5	51.0	M8x1	5	4.86
63 x 40R x 6.5 - 3	61.0	56.4	95	135	BB1	115	13.5	149	30	45	59.5	18.0	117.5	59.5	M8x1	5	5.36
80 x 10R x 6.5 - 6	78.0	73.3	105	145	BB1	125	13.5	95	30	16	32.5	14.0	127.5	32.5	M8x1	5	3.73
80 x 20R x 12.7 - 6	76.0	67.0	125	165	BB1	145	13.5	170	50	25	60.0	24.0	147.5	60.0	M8x1	5	13.50

Cylindrical single nut ZEM-E-S / ZEM-E-K¹⁾ / ZEM-E-A²⁾

Rexroth connection dimensions

With seals Left-hand version in some cases

Preload class: C0, C00, C1, C2, C3

Tolerance grade T3⁴⁾, T5, T7, T9



Ordering data:

BASA	20 x 5R x 3	ZEM-E-S - 5	00	1	2	T7	R	82Z120	41Z120	1250	0	1
------	-------------	-------------	----	---	---	----	---	--------	--------	------	---	---

d_0 = nominal diameter
P = lead (R = right-hand, L = left-hand)
 D_w = ball diameter
i = number of ball track turns

Category	Size $d_0 \times P \times D_w - i$	Part number	Load ratings ⁵⁾		Linear speed ³⁾ v_{max} (m/min)
			dyn. C (N)	stat. C ₀ (N)	
A	16 x 5R x 3 - 4	R1512 010 22	14,800	16,100	30
A	16 x 5R x 3 - 4	R1512 012 67 ¹⁾	14,800	16,100	30
A	16 x 10R x 3 - 3	R1512 040 12	11,500	12,300	60
A	16 x 10R x 3 - 3	R1512 042 08 ¹⁾	11,500	12,300	60
A	16 x 10R x 3 - 3	R1512 042 09 ¹⁾	11,500	12,300	60
A	16 x 16R x 3 - 2	R1512 060 12	7,560	7,600	96
A	16 x 16R x 3 - 2	R1512 062 10 ¹⁾	7,560	7,600	96
A	16 x 16R x 3 - 3	R1512 060 52	11,200	12,300	96
B	16 x 16R x 3 - 3	R1512 062 11 ¹⁾	11,200	12,300	96
B	20 x 5R x 3 - 4	R1512 112 43 ¹⁾	17,200	21,500	30
A	20 x 5R x 3 - 5	R1512 110 12	21,000	27,300	30
A	20 x 10R x 3 - 4	R1512 140 12	16,900	21,300	60
B	20 x 10R x 3 - 4	R1512 142 04 ¹⁾	16,900	21,300	60
A	20 x 20R x 3.5 - 2	R1512 170 12	10,900	12,100	120
B	20 x 20R x 3.5 - 3	R1512 170 52	16,000	18,800	120
A	20 x 20R x 3.5 - 3	R1512 172 07 ¹⁾	16,000	18,800	120
A	25 x 5R x 3 - 4	R1512 210 12	19,100	27,200	30
A	25 x 10R x 3 - 4	R1512 240 12	18,800	27,000	60
A	25 x 25R x 3.5 - 2	R1512 280 12	12,100	15,100	150
A	25 x 25R x 3.5 - 3	R1512 280 52	17,600	23,300	150
A	32 x 5R x 3.5 - 4	R1512 310 12	25,900	40,000	23
A	32 x 5R x 3.5 - 4	R1512 310 52 ²⁾	25,900	40,000	23
A	32 x 10R x 3.969 - 5	R1512 340 12	38,000	58,300	47
A	32 x 10R x 3.969 - 5	R1512 340 52 ²⁾	38,000	58,300	47
B	32 x 20R x 3.969 - 2	R1512 370 12	16,200	21,800	94
A	32 x 20R x 3.969 - 3	R1512 370 52	23,600	33,700	94
B	32 x 32R x 3.969 - 2	R1512 390 12	16,100	22,000	150
A	32 x 32R x 3.969 - 3	R1512 390 52	23,400	34,000	150
A	40 x 5R x 3.5 - 5	R1512 410 12	34,900	64,100	19
B	40 x 5R x 3.5 - 5	R1512 412 21 ¹⁾	34,900	64,100	19
A	40 x 10R x 6 - 4	R1512 440 12	60,000	86,400	38
B	40 x 10R x 6 - 6	R1512 440 22	86,500	132,200	38
A	40 x 20R x 6 - 3	R1512 470 12	45,500	62,800	75
A	40 x 40R x 6 - 2	R1512 490 12	30,600	40,300	150
A	40 x 40R x 6 - 3	R1512 490 52	44,400	62,300	150
B	50 x 5R x 3.5 - 5	R1512 510 12	38,400	81,300	15
A	50 x 10R x 6 - 6	R1512 540 12	95,600	166,500	30
B	50 x 20R x 6.5 - 3	R1512 570 12	57,500	87,900	60
B	63 x 10R x 6 - 6	R1512 640 12	106,600	214,300	24
B	80 x 10R x 6.5 - 6	R1512 740 12	130,100	291,700	19
Versions with left-hand lead					
A	16 x 5L x 3 - 4	R1552 010 02	14,800	16,100	30
B	20 x 5L x 3 - 5	R1552 110 12	21,000	27,300	30
B	20 x 5L x 3 - 4	R1552 112 04 ¹⁾	17,200	21,500	30
B	25 x 5L x 3 - 4	R1552 210 12	19,100	27,200	30
B	32 x 5L x 3.5 - 4	R1552 310 02	25,900	40,000	23
B	40 x 5L x 3.5 - 5	R1552 410 02	34,900	64,100	19
B	40 x 10L x 6 - 4	R1552 440 02	60,000	86,400	38

- 1) ZEM-E-K / nuts for Rexroth modules and drive units
- 2) ZEM-E-A / nuts with mounting dimensions as per DIN 69051, Part 5
- 3) See "Characteristic speed $d_0 \cdot n$ " on page 133 and "Critical speed n_{cr} " on page 174
- 4) Tolerance grade T3 for sizes shown in table page 12
- 5) The load ratings are valid for tolerance grade T3 and T5 only.
For other tolerance grades, please take into account the correction factor f_{ac} on page 133.

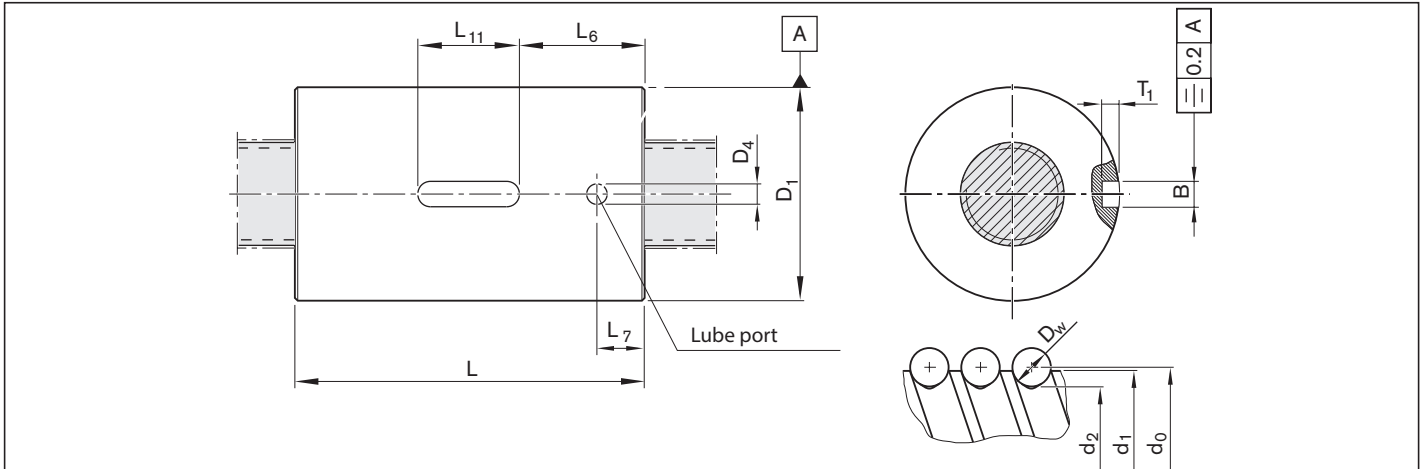

Size d ₀ x P x D _w - i	(mm)											Mass m (kg)
	d ₁	d ₂	D ₁ g6	D ₄	L ±0.1	L ₆	L ₇	L ₁₁ +0.2	B P9	T ₁ +0.1		
16 x 5R x 3 - 4	15.0	12.9	28	4	35	14.5	9.5	12	5	3.0	0.09	
16 x 5R x 3 - 4	15.0	12.9	33	2	45	14.5	9.5	16	5	3.0	0.17	
16 x 10R x 3 - 3	15.0	12.9	28	4	45	14.5	9.5	16	5	3.0	0.12	
16 x 10R x 3 - 3	15.0	12.9	38	4	54	19.0	9.5	16	5	3.0	0.35	
16 x 10R x 3 - 3	15.0	12.9	33	4	45	14.5	9.5	16	5	3.0	0.20	
16 x 16R x 3 - 2	15.0	12.9	33	4	45	14.5	9.5	16	5	3.0	0.20	
16 x 16R x 3 - 2	15.0	12.9	28	4	45	14.5	9.5	16	5	3.0	0.12	
16 x 16R x 3 - 3	15.0	12.9	28	4	61	22.5	9.5	16	5	3.0	0.16	
16 x 16R x 3 - 3	15.0	12.9	38	4	61	22.5	9.5	16	5	3.0	0.42	
20 x 5R x 3 - 4	19.0	16.9	38	4	40	21.0	9.5	12	5	3.0	0.21	
20 x 5R x 3 - 5	19.0	16.9	33	4	45	14.5	9.5	16	5	3.0	0.16	
20 x 10R x 3 - 4	19.0	16.9	33	4	60	22.0	9.5	16	5	3.0	0.31	
20 x 10R x 3 - 4	19.0	16.9	38	4	64	22.0	9.5	20	5	3.0	0.46	
20 x 20R x 3.5 - 2	19.0	16.7	38	4	64	22.0	9.5	20	5	3.0	0.34	
20 x 20R x 3.5 - 3	19.0	16.7	36	4	77	28.5	9.5	20	5	3.0	0.37	
20 x 20R x 3.5 - 3	19.0	16.7	38	4	77	28.5	9.5	20	5	3.0	0.44	
25 x 5R x 3 - 4	24.0	21.9	38	4	45	14.5	9.5	16	5	3.0	0.19	
25 x 10R x 3 - 4	24.0	21.9	38	4	64	22.0	9.5	20	5	3.0	0.28	
25 x 25R x 3.5 - 2	24.0	21.4	48	4	80	30.0	10.5	20	5	3.0	0.73	
25 x 25R x 3.5 - 3	24.0	21.4	40	4	95	37.5	10.5	20	5	3.0	0.50	
32 x 5R x 3.5 - 4	31.0	28.4	48	4	48	14.0	9.5	20	5	3.0	0.32	
32 x 5R x 3.5 - 4	31.0	28.4	50	4	48	14.0	9.5	20	5	3.0	0.35	
32 x 10R x 3.969 - 5	31.0	27.9	48	4	77	28.5	9.5	20	5	3.0	0.50	
32 x 10R x 3.969 - 5	31.0	27.9	50	4	77	28.5	9.5	20	5	3.0	0.61	
32 x 20R x 3.969 - 2	31.0	27.9	56	4	64	22.0	9.5	20	5	3.0	0.74	
32 x 20R x 3.969 - 3	31.0	27.9	50	4	84	32.0	9.5	20	5	3.0	0.66	
32 x 32R x 3.969 - 2	31.0	27.9	56	4	88	34.0	9.5	20	5	3.0	1.03	
32 x 32R x 3.969 - 3	31.0	27.9	50	4	120	50.0	9.5	20	5	3.0	0.97	
40 x 5R x 3.5 - 5	39.0	36.4	56	4	54	17.0	9.5	20	5	3.0	0.44	
40 x 5R x 3.5 - 5	39.0	36.4	63	4	70	25.0	14.0	20	5	3.0	0.82	
40 x 10R x 6 - 4	38.0	33.8	63	4	70	25.0	14.0	20	5	3.0	0.88	
40 x 10R x 6 - 6	38.0	33.8	63	4	90	35.0	14.0	20	5	3.0	1.15	
40 x 20R x 6 - 3	38.0	33.8	63	4	88	34.0	14.0	20	5	3.0	1.13	
40 x 40R x 6 - 2	38.0	33.8	72	4	113	46.5	14.0	20	5	3.0	2.23	
40 x 40R x 6 - 3	38.0	33.8	63	4	142	61.0	14.0	20	5	3.0	1.85	
50 x 5R x 3.5 - 5	49.0	46.4	68	4	54	17.0	9.5	20	5	3.0	0.62	
50 x 10R x 6 - 6	48.0	43.8	72	5	90	35.0	14.0	20	5	3.0	1.34	
50 x 20R x 6.5 - 3	48.0	43.4	85	5	92	30.0	14.0	32	6	3.5	2.39	
63 x 10R x 6 - 6	61.0	56.8	85	5	90	29.0	14.0	32	6	3.5	1.59	
80 x 10R x 6.5 - 6	78.0	73.3	105	5	95	31.5	15.0	32	6	3.5	2.23	
Versions with left-hand lead												
16 x 5L x 3 - 4	15.0	12.9	28	4	35	14.5	9.5	12	5	3.0	0.09	
20 x 5L x 3 - 5	19.0	16.9	33	4	45	14.5	9.5	16	5	3.0	0.16	
20 x 5L x 3 - 4	19.0	16.9	38	4	40	21.0	9.5	12	5	3.0	0.21	
25 x 5L x 3 - 4	24.0	21.9	38	4	45	14.5	9.5	16	5	3.0	0.19	
32 x 5L x 3.5 - 4	31.0	28.4	48	4	48	14.0	9.5	20	5	3.0	0.32	
40 x 5L x 3.5 - 5	39.0	36.4	56	4	54	17.0	9.5	20	5	3.0	0.44	
40 x 10L x 6 - 4	38.0	33.8	63	4	70	25.0	14.0	20	5	3.0	0.88	

Screw-in nut ZEV-E-S

Rexroth connection dimensions

With low-friction seal,
preload class: C0, C00, C1
Tolerance grade T3²⁾, T5, T7, T9



Ordering data:

BASA	20 x 5R x 3	ZEV-E-S - 4	00	0	0	T7	R	81K120	41K120	550	0	0
------	-------------	-------------	----	---	---	----	---	--------	--------	-----	---	---

d_0 = nominal diameter
 P = lead (R = right-hand)
 D_w = ball diameter
 i = number of ball track turns

Category	Size $d_0 \times P \times D_w - i$	Part number	Load ratings ³⁾		Linear speed ¹⁾
			dyn. C (N)	stat. C ₀ (N)	v_{max} (m/min)
A	16 x 5R x 3 - 3	R2542 000 05	11,300	11,800	30.0
A	16 x 10R x 3 - 3	R2542 000 15	11,500	12,300	60.0
B	20 x 5R x 3 - 4	R2542 100 05	17,200	21,500	30.0
A	25 x 5R x 3 - 7	R2542 200 05	31,400	48,700	24.0
A	25 x 10R x 3 - 5	R2542 200 15	23,200	34,200	48.0
B	32 x 5R x 3.5 - 5	R2542 300 05	31,700	50,600	18.8
B	32 x 10R x 3.969 - 5	R2542 300 15	38,000	58,300	37.5

- 1) See "Characteristic speed $d_0 \cdot n$ " on page 133 and "Critical speed n_{cr} " on page 174
- 2) Tolerance grade T3 for sizes shown in table page 12
- 3) The load ratings are valid for tolerance grade T3 and T5 only.
For other tolerance grades, please take into account the correction factor f_{ac} on page 133.

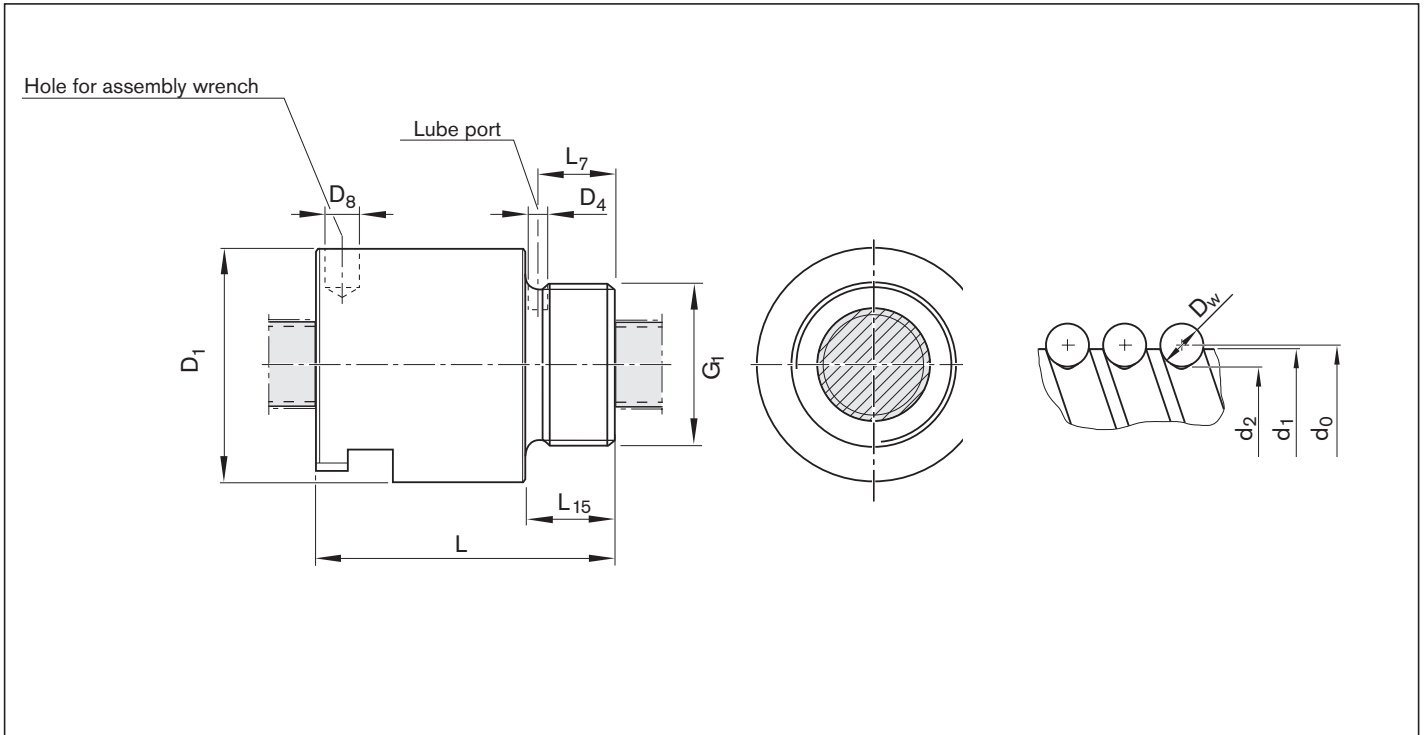

Size	(mm)										Mass	
	d ₁	d ₂	D ₁ h10	D ₄	D ₈	G ₁	L ±0.3	L ₇	L ₁₅	m (kg)		
d ₀ x P x D _w - i												
16 x 5R x 3 - 3	15.0	12.9	32.5	2.7	4.2	M26 x 1.5	40	10.5	12	0.14		
16 x 10R x 3 - 3	15.0	12.9	32.5	2.7	4.2	M26 x 1.5	54	10.5	12	0.21		
20 x 5R x 3 - 4	19.0	16.9	38.0	2.7	8.0	M35 x 1.5	50	12.5	14	0.25		
25 x 5R x 3 - 7	24.0	21.9	43.0	1.5	8.0	M40 x 1.5	60	17.5	19	0.36		
25 x 10R x 3 - 5	24.0	21.9	43.0	2.0	8.0	M40 x 1.5	74	17.7	19	0.45		
32 x 5R x 3.5 - 5	31.0	28.4	54.0	2.7	8.0	M48 x 1.5	69	17.5	19	0.58		
32 x 10R x 3.969 - 5	31.0	27.9	54.0	2.7	8.0	M48 x 1.5	95	17.5	19	0.88		

Double nut with flange FDM-E-S

Rexroth connection dimensions

With seals,
preload class: C4, C5
Tolerance grades T3²⁾, T5, T7

Note: Supplied only as complete ball screw assembly.

⚠ When setting up applications, do not allow components to collide with the front lube unit.



d_0 = nominal diameter
P = lead (R = right-hand)
 D_w = ball diameter
i = number of ball track turns

Ordering data:

BASA	20 x 5R x 3	FDM-E-S - 4	00	1	5	T7	R	82Z120	41Z120	1250	0	1
------	-------------	-------------	----	---	---	----	---	--------	--------	------	---	---

Category	Size $d_0 \times P \times D_w - i$	Part number	Load ratings ³⁾		Linear speed ¹⁾ v_{max} (m/min)
			dyn. C (N)	stat. C ₀ (N)	
B	16 x 5R x 3 - 4	R1502 010 23	14,800	16,100	30
B	20 x 5R x 3 - 4	R1502 110 33	17,200	21,500	30
B	25 x 5R x 3 - 4	R1502 210 33	19,100	27,200	30
B	25 x 10R x 3 - 4	R1502 240 33	18,800	27,000	60
B	32 x 5R x 3.5 - 4	R1502 310 33	25,900	40,000	23
B	32 x 10R x 3.969 - 5	R1502 340 33	38,000	58,300	47
B	40 x 5R x 3.5 - 5	R1502 410 33	34,900	64,100	19
B	40 x 10R x 6 - 4	R1502 440 33	60,000	86,400	38
B	40 x 10R x 6 - 6	R1502 440 34	86,500	132,200	38
B	40 x 20R x 6 - 3	R1502 470 33	45,500	62,800	75
B	50 x 5R x 3.5 - 5	R1502 510 33	38,400	81,300	15
B	50 x 10R x 6 - 4	R1502 540 33	66,500	109,000	30
B	50 x 10R x 6 - 6	R1502 540 34	95,600	166,500	30
B	50 x 20R x 6.5 - 5	R1502 570 34	90,800	149,700	60
B	63 x 10R x 6 - 4	R1502 640 33	74,200	140,500	24
B	63 x 10R x 6 - 6	R1502 640 34	106,600	214,300	24
B	63 x 20R x 6.5 - 5	R1502 670 34	100,700	190,300	48
B	80 x 10R x 6.5 - 6	R1502 740 34	130,100	291,700	19
B	80 x 20R x 12.7 - 6	R1502 770 04	315,200	534,200	30

- 1) See "Characteristic speed $d_0 \cdot n$ " on page 133 and "Critical speed n_{cr} " on page 174
- 2) Tolerance grade T3 for sizes shown in table page 12
- 3) The load ratings are valid for tolerance grade T3 and T5 only.
For other tolerance grades, please take into account the correction factor f_{ac} on page 133.

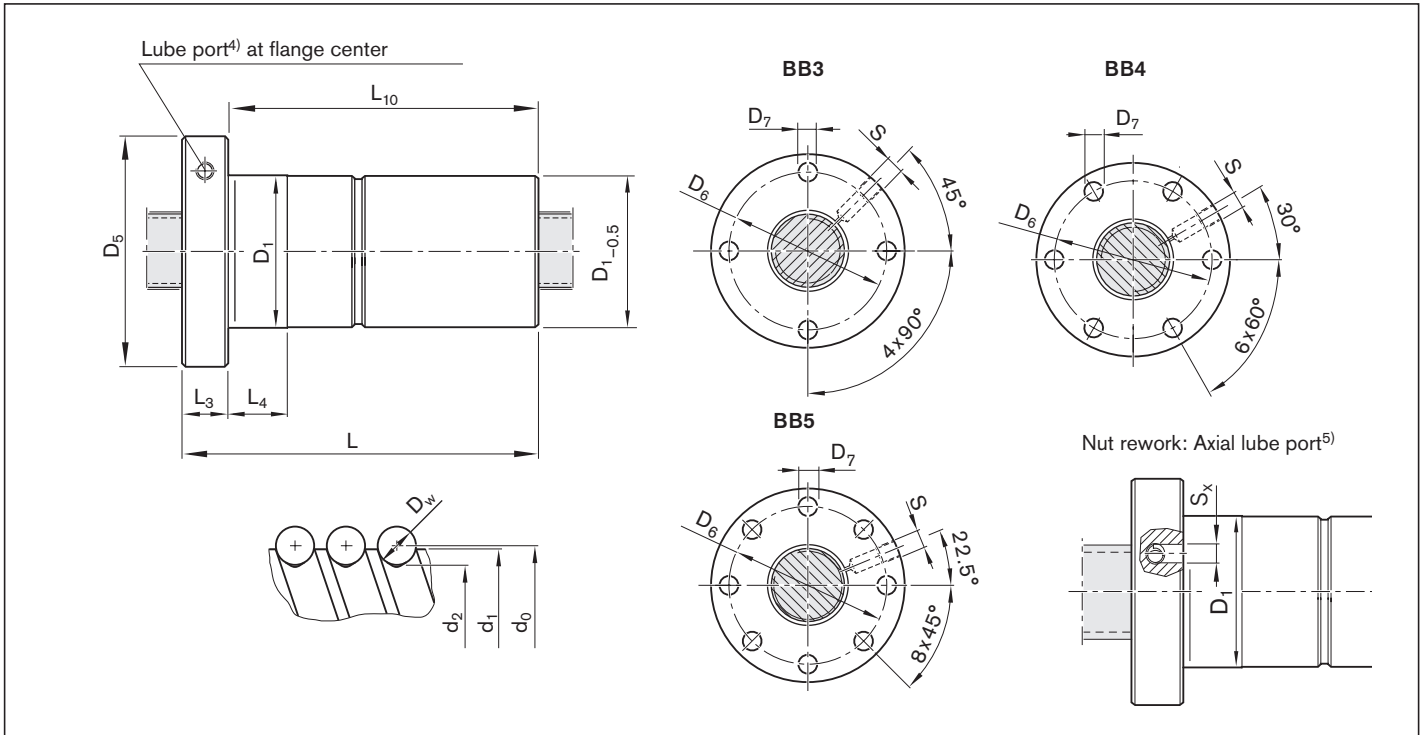

- 4) Lube port machining: flat surface $L_3 \leq 15$ mm, countersink $L_3 > 15$ mm
5) The axial lube port S_x is always located on the pitch circle D_6 of the nut unit.

Size	(mm)													Mass m (kg)
	d_1	d_2	D_1 g6	D_5	Hole pattern	D_6	D_7	L	L_3	L_4	L_{10}	$S^4)$	S_x	
$d_0 \times P \times D_w - i$														
16 x 5R x 3 - 4	15.0	12.9	28	53	BB3	40	6.6	72	12	10	60	M6	4	0.33
20 x 5R x 3 - 4	19.0	16.9	33	58	BB4	45	6.6	82	12	10	70	M6	4	0.45
25 x 5R x 3 - 4	24.0	21.9	38	63	BB4	50	6.6	82	12	10	70	M6	4	0.53
25 x 10R x 3 - 4	24.0	21.9	38	63	BB4	50	6.6	120	12	16	108	M6	4	0.70
32 x 5R x 3.5 - 4	31.0	28.4	48	73	BB4	60	6.6	88	13	10	75	M6	4	0.84
32 x 10R x 3.969 - 5	31.0	27.9	48	73	BB4	60	6.6	146	13	16	133	M6	4	1.22
40 x 5R x 3.5 - 5	39.0	36.4	56	80	BB4	68	6.6	100	15	10	85	M8x1	5	1.13
40 x 10R x 6 - 4	38.0	33.8	63	95	BB4	78	9.0	140	15	16	125	M8x1	5	2.25
40 x 10R x 6 - 6	38.0	33.8	63	95	BB4	78	9.0	180	15	16	165	M8x1	5	2.83
40 x 20R x 6 - 3	38.0	33.8	63	95	BB4	78	9.0	175	15	25	160	M8x1	5	2.66
50 x 5R x 3.5 - 5	49.0	46.4	68	98	BB4	82	9.0	100	15	10	85	M8x1	5	1.60
50 x 10R x 6 - 4	48.0	43.8	72	110	BB4	90	11.0	140	18	16	122	M8x1	5	2.74
50 x 10R x 6 - 6	48.0	43.8	72	110	BB4	90	11.0	180	18	16	162	M8x1	5	3.39
50 x 20R x 6.5 - 5	48.0	43.4	85	125	BB4	105	11.0	255	22	25	233	M8x1	5	6.71
63 x 10R x 6 - 4	61.0	56.8	85	125	BB4	105	11.0	140	22	16	118	M8x1	5	3.53
63 x 10R x 6 - 6	61.0	56.8	85	125	BB4	105	11.0	180	22	16	158	M8x1	5	4.32
63 x 20R x 6.5 - 5	61.0	56.3	95	140	BB4	118	14.0	255	22	25	233	M8x1	5	8.65
80 x 10R x 6.5 - 6	78.0	73.3	105	150	BB4	125	14.0	190	22	16	168	M8x1	5	6.35
80 x 20R x 12.7 - 6	76.0	67.0	125	180	BB5	152	18.0	340	25	25	315	M8x1	5	20.20

Double nut with flange FDM-E-B

Mounting dimensions similar to
DIN 69051, Part 5
Flange type B

With seals, preload class: C4, C5
Tolerance grades T3²⁾, T5, T7

Note: Supplied only as complete
ball screw assembly.

⚠ When setting up applications, do not
allow components to collide with the
front lube unit.



d_0 = nominal diameter
 P = lead (R = right-hand)
 D_w = ball diameter
 i = number of ball track turns

Ordering data:

BASA	20 x 5R x 3	FDM-E-B - 4	00	1	5	T7	R	82Z120	41Z120	1250	0	1
------	-------------	-------------	----	---	---	----	---	--------	--------	------	---	---

Category	Size $d_0 \times P \times D_w - i$	Part number	Load ratings ³⁾		Linear speed ¹⁾ v_{max} (m/min)
			dyn. C (N)	stat. C ₀ (N)	
B	16 x 5R x 3 - 4	R1502 010 53	14,800	16,100	30
B	20 x 5R x 3 - 4	R1502 110 73	17,200	21,500	30
B	25 x 5R x 3 - 4	R1502 210 73	19,100	27,200	30
B	25 x 10R x 3 - 4	R1502 240 73	18,800	27,000	60
B	32 x 5R x 3.5 - 4	R1502 310 73	25,900	40,000	23
B	32 x 10R x 3.969 - 5	R1502 340 74	38,000	58,300	47
B	40 x 5R x 3.5 - 5	R1502 410 74	34,900	64,100	19
B	40 x 10R x 6 - 4	R1502 440 73	60,000	86,400	38
B	40 x 10R x 6 - 6	R1502 440 74	86,500	132,200	38
B	40 x 20R x 6 - 3	R1502 470 73	45,500	62,800	75
B	50 x 5R x 3.5 - 5	R1502 510 74	38,400	81,300	15
B	50 x 10R x 6 - 4	R1502 540 73	66,500	109,000	30
B	50 x 10R x 6 - 6	R1502 540 74	95,600	166,500	30
B	50 x 20R x 6.5 - 5	R1502 570 74	90,800	149,700	60
B	63 x 10R x 6 - 4	R1502 640 73	74,200	140,500	24
B	63 x 10R x 6 - 6	R1502 640 74	106,600	214,300	24
B	63 x 20R x 6.5 - 5	R1502 670 74	100,700	190,300	48
B	80 x 10R x 6.5 - 6	R1502 740 74	130,100	291,700	19
B	80 x 20R x 12.7 - 6	R1502 770 44	315,200	534,200	30

- 1) See "Characteristic speed $d_0 \cdot n$ " on page 133 and "Critical speed $n_{c,r}$ " on page 174
- 2) Tolerance grade T3 for sizes shown in table page 12
- 3) The load ratings are valid for tolerance grade T3 and T5 only.
For other tolerance grades, please take into account the correction factor f_{ac} on page 133.

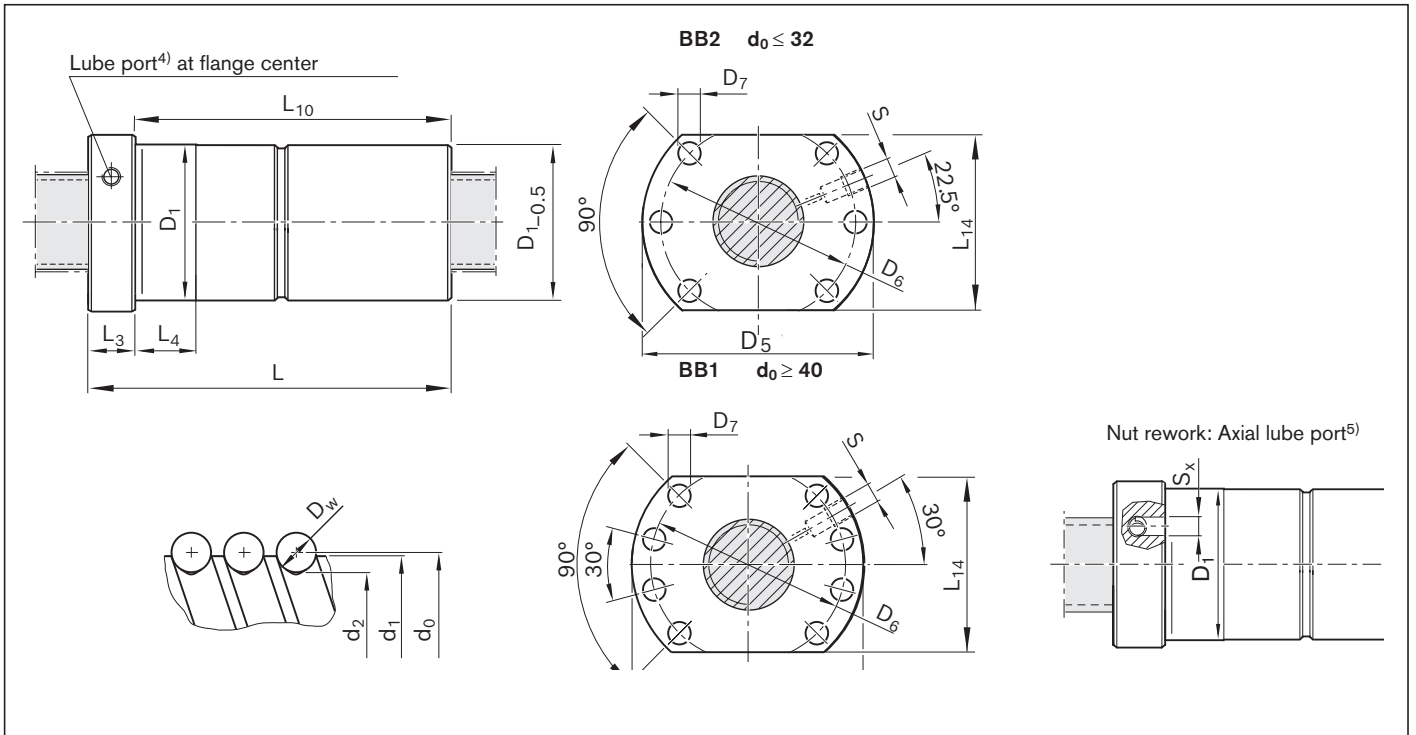

- 4) Lube port machining: flat surface $L_3 \leq 15$ mm, countersink $L_3 > 15$ mm
5) The axial lube port S_x is always located on the pitch circle D_6 of the nut unit.

Size	(mm)															Mass m (kg)
	d_1	d_2	D_1 g6	D_5	Hole pattern	D_6	D_7	L	L_3	L_4	L_{10}	L_{14}	$S^4)$	S_x		
$d_0 \times P \times D_w - i$																
16 x 5R x 3 - 4	15.0	12.9	28	48	BB2	38	5.5	72	12	10	60	40.0	M6	4	0.29	
20 x 5R x 3 - 4	19.0	16.9	36	58	BB2	47	6.6	82	12	10	70	44.0	M6	4	0.53	
25 x 5R x 3 - 4	24.0	21.9	40	62	BB2	51	6.6	82	12	10	70	48.0	M6	4	0.57	
25 x 10R x 3 - 4	24.0	21.9	40	62	BB2	51	6.6	120	12	16	108	48.0	M6	4	0.77	
32 x 5R x 3.5 - 4	31.0	28.4	50	80	BB2	65	9.0	88	13	10	75	62.0	M6	4	0.96	
32 x 10R x 3.969 - 5	31.0	27.9	50	80	BB2	65	9.0	146	13	16	133	62.0	M6	4	1.34	
40 x 5R x 3.5 - 5	39.0	36.4	63	93	BB1	78	9.0	100	15	10	85	70.0	M8x1	5	1.68	
40 x 10R x 6 - 4	38.0	33.8	63	93	BB1	78	9.0	140	15	16	125	70.0	M8x1	5	2.15	
40 x 10R x 6 - 6	38.0	33.8	63	93	BB1	78	9.0	180	15	16	165	70.0	M8x1	5	2.73	
40 x 20R x 6 - 3	38.0	33.8	63	93	BB1	78	9.0	175	15	25	160	70.0	M8x1	5	2.56	
50 x 5R x 3.5 - 5	49.0	46.4	75	110	BB1	93	11.0	100	15	10	85	85.0	M8x1	5	2.25	
50 x 10R x 6 - 4	48.0	43.8	75	110	BB1	93	11.0	140	18	16	122	85.0	M8x1	5	2.97	
50 x 10R x 6 - 6	48.0	43.8	75	110	BB1	93	11.0	180	18	16	162	85.0	M8x1	5	3.73	
50 x 20R x 6.5 - 5	48.0	43.3	75	110	BB1	93	11.0	255	18	25	237	85.0	M8x1	5	4.93	
63 x 10R x 6 - 4	61.0	56.8	90	125	BB1	108	11.0	140	22	16	118	95.0	M8x1	5	4.00	
63 x 10R x 6 - 6	61.0	56.8	90	125	BB1	108	11.0	180	22	16	158	110.0	M8x1	5	4.45	
63 x 20R x 6.5 - 5	61.0	56.3	95	135	BB1	115	13.5	255	22	25	233	100.0	M8x1	5	8.21	
80 x 10R x 6.5 - 6	78.0	73.3	105	145	BB1	125	13.5	190	22	16	168	110.0	M8x1	5	5.93	
80 x 20R x 12.7 - 6	76.0	67.0	125	165	BB1	145	13.5	340	25	25	315	130.0	M8x1	5	19.40	

Nuts, high-performance series

High-performance series

HP series ball screw assemblies are available with nominal diameters of 20 – 63 mm, and leads of 10 – 40 mm. The HP nut type is a single nut with flange which is available with a driven screw or as a driven nut.

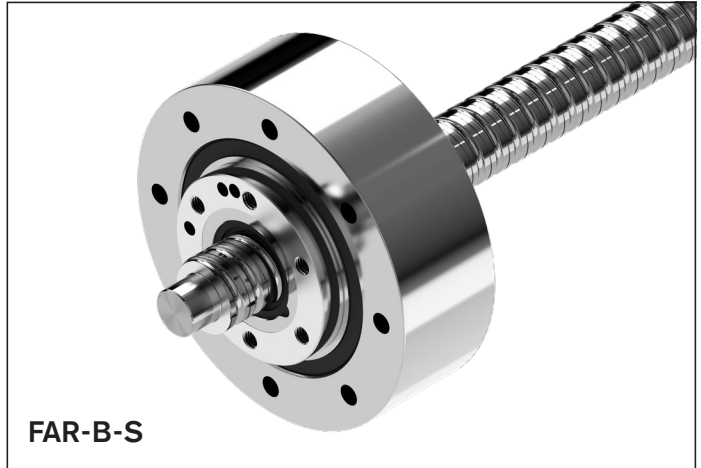
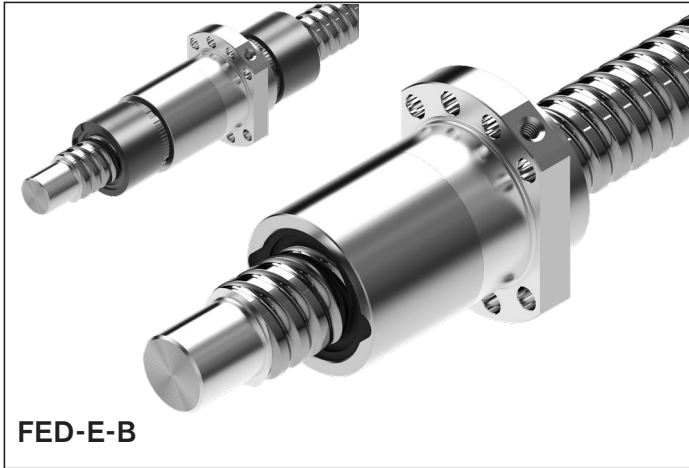

Preload classes

Option	Preload class	Definition
0	C0	Standard backlash
1	C00	Reduced backlash
2	C3	High preload (single nut)
3	C1	Moderate preload (single nut)
4	C4	High preload (double nut)
5	C5	Average preload (double nut)
6	C2	Average preload (single nut)

See nut versions for allocation of the preload classes

Driven single nut with flange FAR-B-S

Fundamental advantages of systems with driven nuts

Moment of inertia

In the case of long screws, the screw does not have to be rotated in the acceleration phase, only the nut.

The mass moment of inertia of the screw is not therefore critical. The moment of inertia of the nut is comparatively low and it is no longer dependent on the required stroke.

Dynamics

The intricate end bearing designs required for high dynamics, for example, fixed bearing on both ends with angular-contact ball bearings, are no longer necessary.

Screw extenders

Since the screw is stationary, relatively effort is needed to stretch the screw

- Increase in permissible axial loading (buckling load); not limited by end bearings
- Compensation of temperature influences
- Increase in overall rigidity

Design and manufacturing tolerances

The use of nuts with a high level of axial and radial runout precision minimizes the induced screw vibration. All functional components are supplied from a single source. In-house designs are no longer needed.

Liquid cooling

Improved cooling can easily be provided by using a hollow-bored screw:

cooling of the stationary screw can be provided with comparatively little effort. Controlled cooling virtually eliminates changes in length due to temperature fluctuations.

User benefits

- Economic efficiency provided by complete unit
- Adjustment to various speeds and loads is possible using the screw lead and the speed reducing belt
- Small installation space thanks to its compact construction
- Integral functionality and little installation work for the customer
- Low system costs
- High positioning accuracy
- For particularly demanding positioning tasks, it can be combined with the direct position measuring system that is integrated in the guide rail

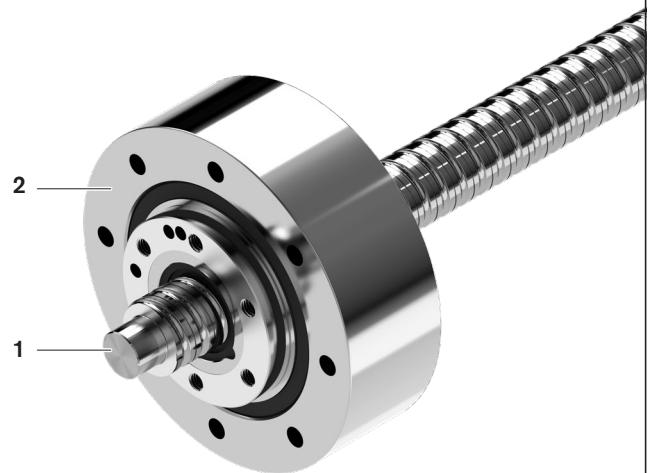

1 Ball screw assemblies (BASA) screw
2 Driven nut FAR

Single nut with flange FED-E-B

Mounting dimensions similar to
DIN 69051, Part 5 flange type B

Nut for significantly increasing the dynamic
and static load capacity
With standard seals
Preload class: C0, C00, C1, C2
Tolerance grade T3¹⁾, T5, T7, T9

⚠ When setting up applications, do not
allow components to collide with the
front lube unit.



Ordering data:

BASA	40x20R x 6	FED-E-B - 8	00	1	2	T5	R	82Z300	41K300	1250	0	1
------	------------	-------------	----	---	---	----	---	--------	--------	------	---	---

Category	Size $d_0 \times P \times D_W - i$	Part number	Load ratings ³⁾		Linear speed ²⁾ v_{max} (m/min)
			dyn. C (N)	stat. C ₀ (N)	
B	16 x 16 R x 3 - 6	R1512 060 32	17 800	24 200	96
B	20 x 20 R x 3.5 - 6	R1512 170 32	25 700	38 100	120
B	25 x 25 R x 3.5 - 6	R1512 280 32	28 500	47 100	150
A	32 x 20 R x 3.969 - 6	R1512 370 32	38 300	67 300	94
A	32 x 32 R x 3.969 - 6	R1512 390 32	37 900	68 000	150
A	40 x 20 R x 6 - 8	R1512 470 32	95 500	171 100	75
B	40 x 25 R x 6 - 8	R1512 480 32	91 400	171 700	93
B	40 x 30 R x 6 - 8	R1512 4A0 32	90 400	170 300	112
A	40 x 40 R x 6 - 6	R1512 490 32	71 500	124 500	150
A	50 x 20 R x 6.5 - 8	R1512 570 32	116 500	240 000	60
B	50 x 25 R x 6.5 - 6	R1512 580 32	92 600	175 100	75
B	50 x 30 R x 6.5 - 6	R1512 5A0 32	114 500	237 700	90
B	50 x 40 R x 6.5 - 6	R1512 590 32	89 300	171 500	120
A	63 x 20 R x 6.5 - 8	R1512 670 32	130 800	292 000	48
A	63 x 40 R x 6.5 - 6	R1512 690 32	100 000	230 600	95

1) Tolerance grade T3 for sizes shown in table page 12

2) See "Characteristic speed $d_0 \cdot n$ " on page 133 and "Critical speed n_{cr} " on page 174

3) The load ratings are valid for tolerance grade T3 and T5 only.

For other tolerance grades, please take into account the correction factor f_{acc} on page 133.

d_0 = nominal diameter
P = lead (R = right-hand)
 D_W = ball diameter
i = number of ball track turns

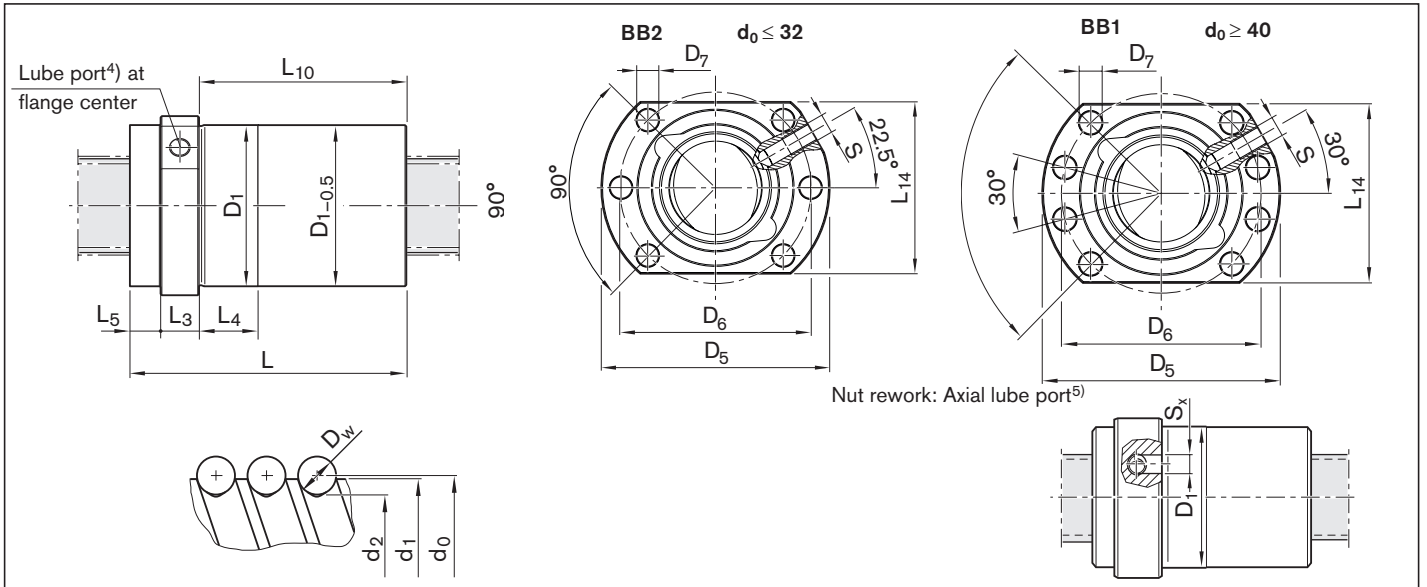

- 4) Lube port machining: flat surface $L_3 \leq 15$ mm, countersink $L_3 > 15$ mm
 5) The axial lube port S_x is always located on the pitch circle D_6 of the nut unit.

Size $d_0 \times P \times D_w - i$	(mm)															Mass m (kg)
	d_1	d_2	D_1 g6	D_5	Hole pattern	D_6	D_7	L	L_3	L_4	L_5	L_{10}	L_{14}	$S^4)$	S_x	
16 x 16 R x 3 - 6	15.0	12.9	28	48	BB2	38	5.5	61	12	20	6.0	43.0	40	M6	4	0.27
20 x 20 R x 3.5 - 6	19.0	16.7	36	58	BB2	47	6.6	77	12	25	8.0	57.0	44	M6	4	0.48
25 x 25 R x 3.5 - 6	24.0	21.4	40	62	BB2	51	6.6	95	12	30	9.0	74.0	48	M6	4	0.63
32 x 20 R x 3.969 - 6	31.0	27.9	50	80	BB2	65	9.0	84	13	25	11.0	60.0	62	M6	4	0.91
32 x 32 R x 3.969 - 6	31.0	27.9	50	80	BB2	65	9.0	120	13	40	12.0	95.0	62	M6	4	1.25
40 x 20 R x 6 - 8	38.0	33.8	63	93	BB1	78	9.0	108	15	25	13.0	80.0	70	M8x1	5	1.85
40 x 25 R x 6 - 8	38.0	33.8	63	93	BB1	78	9.0	127	15	30	11.5	100.5	70	M8x1	5	1.88
40 x 30 R x 6 - 8	38.0	33.8	63	93	BB1	78	9.0	145	15	35	11.5	118.5	70	M8x1	5	2.13
40 x 40 R x 6 - 6	38.0	33.8	63	93	BB1	78	9.0	142	15	45	11.5	115.5	70	M8x1	5	2.35
50 x 20 R x 6.5 - 8	48.0	43.3	75	110	BB1	93	11.0	112	18	25	13.0	81.0	85	M8x1	5	2.50
50 x 25 R x 6.5 - 6	48.0	43.3	75	110	BB1	93	11.0	107	18	25	13.5	75.5	85	M8x1	5	2.45
50 x 30 R x 6.5 - 6	48.0	43.3	75	110	BB1	93	11.0	151	18	35	15.0	118.0	85	M8x1	5	3.04
50 x 40 R x 6.5 - 6	48.0	43.3	75	110	BB1	93	11.0	149	18	45	15.0	116.0	85	M8x1	5	3.40
63 x 20 R x 6.5 - 8	61.0	56.3	95	135	BB1	115	13.5	112	22	25	11.0	79.0	100	M8x1	5	3.90
63 x 40 R x 6.5 - 6	61.0	56.3	95	135	BB1	115	13.5	149	22	45	12.0	115.0	100	M8x1	5	5.05

Driven single nut with flange FAR-B-S

Rexroth connection dimensions

With seals,
preload class: C1, C2, C3
Tolerance grade T3²⁾, T5, T7

The unit consists of:
nut, angular-contact thrust ball bearing and
slotted nut NMZ

When in standstill, it can be relubricated
with NLGI Class 2 grease via the stationary
lube port of the bearing outer race

Note: Supplied only as complete
ball screw assembly.

d_0 = nominal diameter
 P = lead (R = right-hand)
 D_w = ball diameter
 i = number of ball track turns

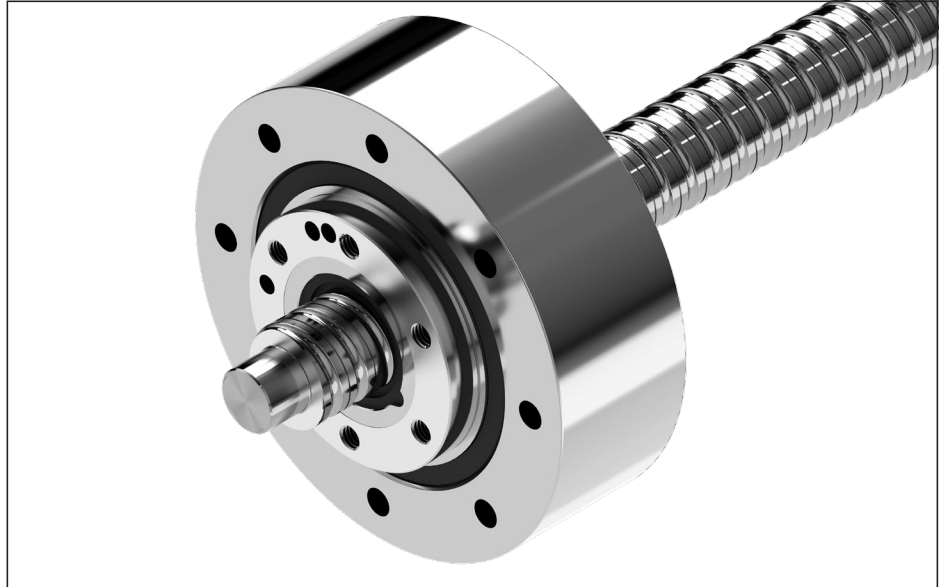

Ordering data:

BASA	40x20R x 6	FAR-B-S - 3	00	1	6	T5	R	51K300	51K300	1250	0	1
------	------------	-------------	----	---	---	----	---	--------	--------	------	---	---

Cat- egory	FAR size	Size $d_0 \times P \times D_w - i$	Part number Module	Load ratings ^{1) 4)}		Mass m_{FAR} (kg)	Mass moment of inertia J_{rotFAR} ($kg \cdot m^2 \cdot 10^{-4}$)	Frictional torque Bearing		Max. speed ³⁾ n_G (rpm)
				dyn. C (N)	stat. C ₀ (N)			M _{RL} (Nm)		
A	32	32 x 10R x 3.969 - 5	R2532 301 01	38,000	58,300	5.8	22.5	1.0	3 000	
B		32 x 20R x 3.969 - 3	R2532 301 11	23,600	33,700	5.9	22.9			
B		32 x 32R x 3.969 - 3	R2532 301 21	23,400	34,000	6.3	25.1			
A	40	40 x 10R x 6 - 5	R2532 401 01	73,400	109,300	7.3	42.7	1.2	2 800	
B		40 x 20R x 6 - 3	R2532 401 31	45,500	62,800	7.5	43.9			
B		40 x 40R x 6 - 3	R2532 401 41	44,400	62,300	8.4	50.7			
A	50	50 x 10R x 6 - 6	R2532 501 01	95,600	166,500	8.3	67.6	1.4	2 700	
B		50 x 20R x 6.5 - 5	R2532 501 31	90,800	149,700	9.1	76.0			
B		50 x 40R x 6.5 - 3	R2532 501 41	55,800	85,900	9.5	79.8			
B	63	63 x 10R x 6 - 6	R2532 601 01	106,600	214,300	12.8	139.0	2.3	2 300	
B		63 x 20R x 6.5 - 5	R2532 601 11	100,700	190,300	13.5	156.4			
B		63 x 40R x 6.5 - 3	R2532 601 21	64,100	114,100	13.9	161.6			

1) Load ratings calculated according to DIN ISO 3408-5

2) Tolerance grade T3 for sizes shown in table page 12

3) Limited by the max. speed of the bearing. Bearing pre-tensioned without external operating load. Duty cycle 25%; max. steady-state temp. +50 °C

4) The load ratings are valid for tolerance grade T3 and T5 only.

For other tolerance grades, please take into account the correction factor f_{ac} on page 133.

FAR rigidity levels

FAR size	Size $d_0 \times P \times D_w - i$	Rigidity		Overall rigidity of the nut unit (N/ μ m)		
		Screw R_S (Nm/ μ m)	Bearing R_{aL} (N/ μ m)	Preload class C1 R_G	Preload class C2 R_G	Preload class C3 R_G
32	32 x 10R x 3.969 - 5	141	860	320	350	380
	32 x 20R x 3.969 - 3	141	860	220	250	280
	32 x 32R x 3.969 - 3	141	860	220	240	270
40	40 x 10R x 6 - 5	211	950	390	420	450
	40 x 20R x 6 - 3	211	950	270	300	330
	40 x 40R x 6 - 3	211	950	270	290	330
50	50 x 10R x 6 - 6	345	1,050	490	520	560
	50 x 20R x 6.5 - 5	340	1,050	450	480	530
	50 x 40R x 6.5 - 3	340	1,050	320	350	390
63	63 x 10R x 6 - 6	569	1,150	560	600	640
	63 x 20R x 6.5 - 5	563	1,150	520	560	610
	63 x 40R x 6.5 - 3	563	1,150	390	420	460

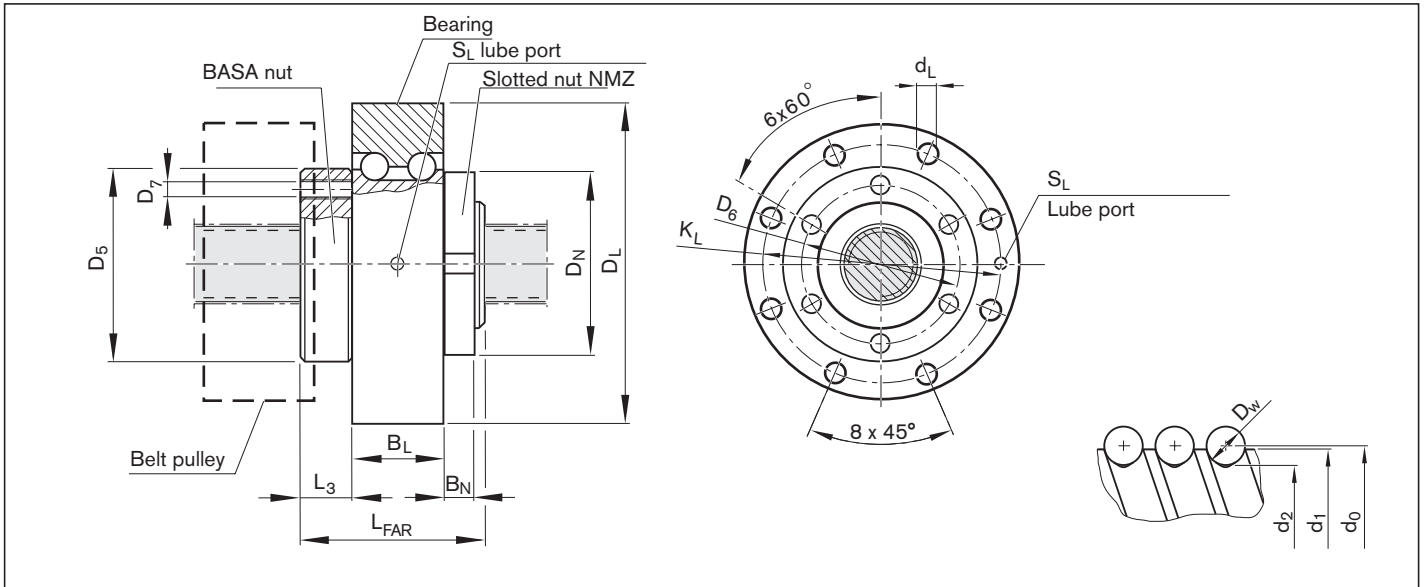

FAR size	Size $d_0 \times P \times D_w - i$	Dimensions (mm)													
		d_1	d_2	L_{FAR}	D_5 h6	D_6	D_7	L_3	D_L -0.018	B_L	K_L	d_L +0.3/-0.1	$S_L^{5)}$	D_N	B_N
32	32 x 10R x 3.969 - 5	31	27.9	77	80	65	M8	11	145	49	120	8.8	M6	75	16
	84														
	120														
40	40 x 10R x 6 - 5	38	33.8	80	93	80	M8	12	155	49	130	8.8	M6	92	18
	88														
	142														
50	50 x 10R x 6 - 6	48	43.8	90	105	90	M8	13	165	49	140	8.8	M6	105	18
	43.3		132												
	149														
63	63 x 10R x 6 - 6	61	56.8	100	130	110	M10	20	190	60	165	11.0	M6	120	20
	56.3		132												
	149														

5) Condition on delivery: lube ports S_L sealed by setscrews (M6).
The desired lube port can be opened by removing the set screw.

Precision screw

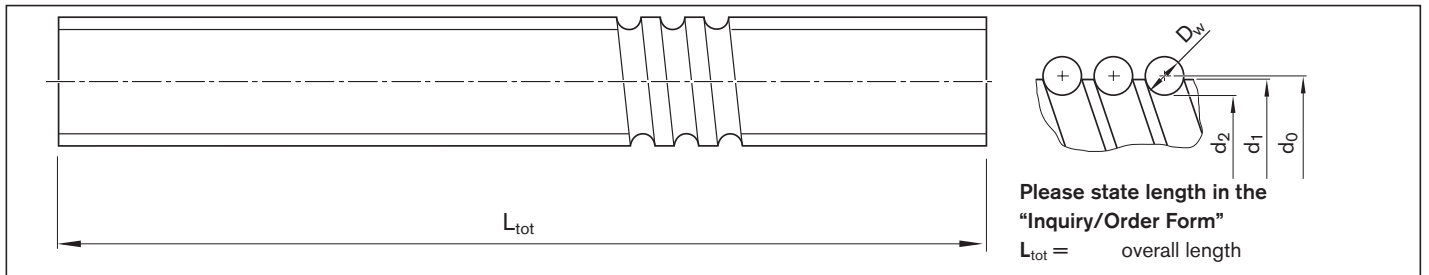





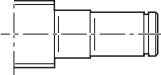
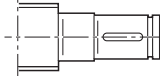
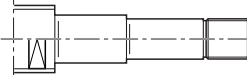
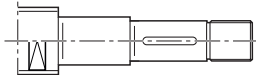

Size d ₀ x P x D _w	Part number Tolerance grade			(mm)		Moment of inertia J _s (kg · cm ² /m)	Maximum length (mm)		Mass (kg/m)
	T5	T7	T9	d ₁	d ₂		Standard	on request	
6 ¹⁾ x 1R x 0.8	–	–	–	6.0	5.3	0.02	–	–	0.19
6 ¹⁾ x 2R x 0.8	–	–	–	6.0	5.3	0.02	–	–	0.19
8 ¹⁾ x 1R x 0.8	–	–	–	8.0	7.3	0.04	–	–	0.36
8 ¹⁾ x 2R x 1.2	–	–	–	8.0	7.0	0.04	–	–	0.36
8 x 2.5R x 1.588	R1531 235 00	R1531 237 00	R1531 239 00	7.5	6.3	0.04	1 500	2 500	0.30
8 x 5R x 1.588	R1531 265 00	R1531 267 00	R1531 269 00	7.5	6.3	0.04	1 500	2 500	0.30
12 ¹⁾ x 2R x 1.2	–	–	–	11.7	10.7	0.13	–	–	0.79
12 x 5R x 2	R1531 465 10	R1531 467 10	R1531 469 10	11.4	9.9	0.11	1 500	2 500	0.75
12 x 10R x 2	R1531 495 00	R1531 497 00	R1531 499 00	11.4	9.9	0.11	–	–	0.74
16 x 5L x 3	R1551 015 00	R1551 017 00	R1551 019 00	15.0	12.9	0.31	1 500	3 500	1.24
16 x 5R x 3	R1511 015 00	R1511 017 00	R1511 019 00	15.0	12.9	0.31	–	–	1.24
16 x 10R x 3	R1511 045 00	R1511 047 00	R1511 049 00	15.0	12.9	0.31	–	–	1.23
16 x 16R x 3	R1511 065 10	R1511 067 10	R1511 069 10	15.0	12.9	0.34	–	–	1.29
20 x 5R x 3	R1511 115 00	R1511 117 00	R1511 119 00	19.0	16.9	0.84	1 500	3 500	2.03
20 x 5L x 3	R1551 115 00	R1551 117 00	R1551 119 00	19.0	16.9	0.84	–	–	2.03
20 x 10R x 3	R1511 145 00	R1511 147 00	R1511 149 00	19.0	16.9	0.84	–	–	2.03
20 x 20R x 3.5	R1511 175 10	R1511 177 10	R1511 179 10	19.0	16.7	0.81	–	–	1.99
20 ¹⁾ x 40R x 3.5	–	–	–	19.0	16.4	0.86	–	–	2.06
25 x 5R x 3	R1511 215 00	R1511 217 00	R1511 219 00	24.0	21.9	2.22	2 500	5 500	3.31
25 x 5L x 3	R1551 215 00	R1551 217 00	R1551 219 00	24.0	21.9	2.22	–	–	3.31
25 x 10R x 3	R1511 245 00	R1511 247 00	R1511 249 00	24.0	21.9	2.39	–	–	3.43
25 x 25R x 3.5	R1511 285 10	R1511 287 10	R1511 289 10	24.0	21.4	2.15	–	–	3.25
32 x 5R x 3.5	R1511 315 00	R1511 317 00	R1511 319 00	31.0	28.4	6.05	2 500	5 500	5.45
32 x 5L x 3.5	R1551 315 00	R1551 317 00	R1551 319 00	31.0	28.4	6.05	–	–	5.45
32 x 10R x 3.969	R1511 345 10	R1511 347 10	R1511 349 10	31.0	27.9	6.40	–	–	5.60
32 x 20R x 3.969	R1511 375 10	R1511 377 10	R1511 379 10	31.0	27.9	6.39	–	–	5.60
32 x 32R x 3.969	R1511 395 10	R1511 397 10	R1511 399 10	31.0	27.9	6.17	–	–	5.50
32 ¹⁾ x 64R x 3.969	–	–	–	31.0	27.9	6.04	–	–	5.44
40 x 5R x 3.5	R1511 415 00	R1511 417 00	R1511 419 00	39.0	36.4	15.64	4 500	5 500	8.78
40 x 5L x 3.5	R1551 415 00	R1551 417 00	R1551 419 00	39.0	36.4	15.64	–	–	8.78
40 x 10R x 6	R1511 445 00	R1511 447 00	R1511 449 00	38.0	33.8	13.55	–	7 500	8.15
40 x 10L x 6	R1551 445 00	R1551 447 00	R1551 449 00	38.0	33.8	13.55	–	–	8.15
40 x 12R x 6	R1511 455 00	R1511 457 00	R1511 459 00	38.0	33.8	13.97	–	5 000	8.27
40 x 16R x 6	R1511 465 00	R1511 467 00	R1511 469 00	38.0	33.8	12.90	–	–	7.95
40 x 20R x 6	R1511 475 00	R1511 477 00	R1511 479 00	38.0	33.8	13.52	–	7 500	8.14
40 x 25R x 6	R1511 485 00	R1511 487 00	R1511 489 00	38.0	33.8	13.51	–	5 000	8.67
40 x 30R x 6	R1511 4A5 00	R1511 4A7 00	R1511 4A9 00	38.0	33.8	13.71	–	–	8.67
40 x 40R x 6	R1511 495 10	R1511 497 10	R1511 499 10	38.0	33.8	13.42	–	7 500	8.11
50 x 5R x 3.5	R1511 515 00	R1511 517 00	R1511 519 00	49.0	46.4	40.03	4 500	5 500	14.05
50 x 10R x 6	R1511 545 00	R1511 547 00	R1511 549 00	48.0	43.8	35.71	–	7 500	13.25
50 x 12R x 6	R1511 555 00	R1511 557 00	R1511 559 00	48.0	43.8	36.58	–	5 000	13.41
50 x 16R x 6	R1511 565 00	R1511 567 00	R1511 569 00	48.0	43.8	34.37	–	–	13.00
50 x 20R x 6.5	R1511 575 10	R1511 577 10	R1511 579 10	48.0	43.3	34.50	–	7 500	13.01
50 x 25R x 6.5	R1511 585 00	R1511 587 00	R1511 589 00	48.0	43.3	32.40	–	–	12.58
50 x 30R x 6.5	R1511 5A5 00	R1511 5A7 00	R1511 5A9 00	48.0	43.3	36.64	–	5 000	13.42
50 x 40R x 6.5	R1511 595 10	R1511 597 10	R1511 599 10	48.0	43.3	34.34	–	7 500	12.98
63 x 10R x 6	R1511 645 00	R1511 647 00	R1511 649 00	61.0	56.8	95.82	4 500	7 500	21.72
63 x 20R x 6.5	R1511 675 10	R1511 677 10	R1511 679 10	61.0	56.3	93.29	–	–	21.42
63 x 40R x 6.5	R1511 695 10	R1511 697 10	R1511 699 10	61.0	56.3	93.08	–	–	21.40
80 x 10R x 6.5	R1511 745 00	R1511 747 00	R1511 749 00	78.0	73.3	256.86	4 500	7 500	35.58
80 ¹⁾ x 20R x 12.7	–	–	–	76.0	67.0	211.51	–	–	32.16
80 ¹⁾ x 40R x 12.7	–	–	–	76.0	67.0	243.51	–	–	33.88

1) Size not available as cut length

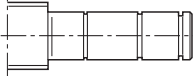
Overview of screw ends

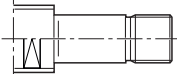
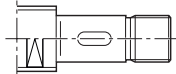
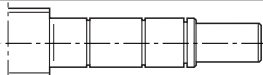
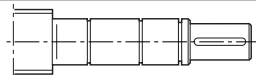
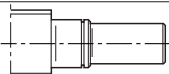
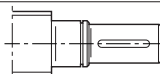
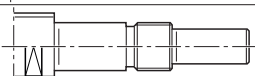
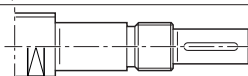
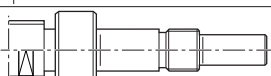
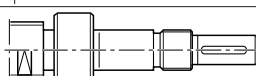
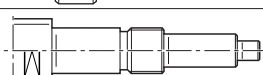
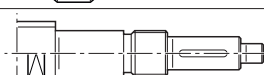
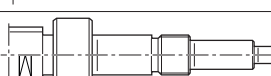
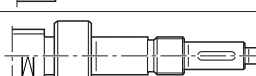
Screw ends, forms for a left or right screw end

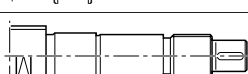
Basic version		with keyway	
00		page 59	
L1		page 60	
			02  page 62
K1 K1A		page 64	
			12 12A  page 66
21		page 68	22  page 68
31		page 70	
41		page 72	
51 51A		page 74	52 52A  page 74
61		page 76	62  page 76
71		page 78	72  page 78
81 81A		page 80	82 82A  page 80
831/83 83A		page 84	841/84 84A  page 84
91 91A		page 86	92 92A  page 86
931/93 93A		page 88	941/94 94A  page 88
N1 N1A		page 90	N2 N2A  page 90

End machining of end-face

Z Centering hole DIN 332-D	S Hex socket	G Female thread
		

Abbreviations

- C = dynamic load rating
- C₀ = static load rating
- d₀ x P = size
- d₀ = nominal diameter
- F_{aB} = axial breaking load of slotted nut
- G = female thread
- n_G = limit speed (grease)
- No. = part number
- M_A = tightening torque of slotted nut
- M_{AG} = tightening torque of set screw
- M_{RL} = bearing friction torque with seal
- M_p = maximum permissible drive torque (condition: no radial load at drive journal)
- R_{fb} = rigidity (axial)
- R_{ki} = rigidity against tilting
- P = lead (R = right-hand)
- S = hex socket
- Z = centering hole

Form 00

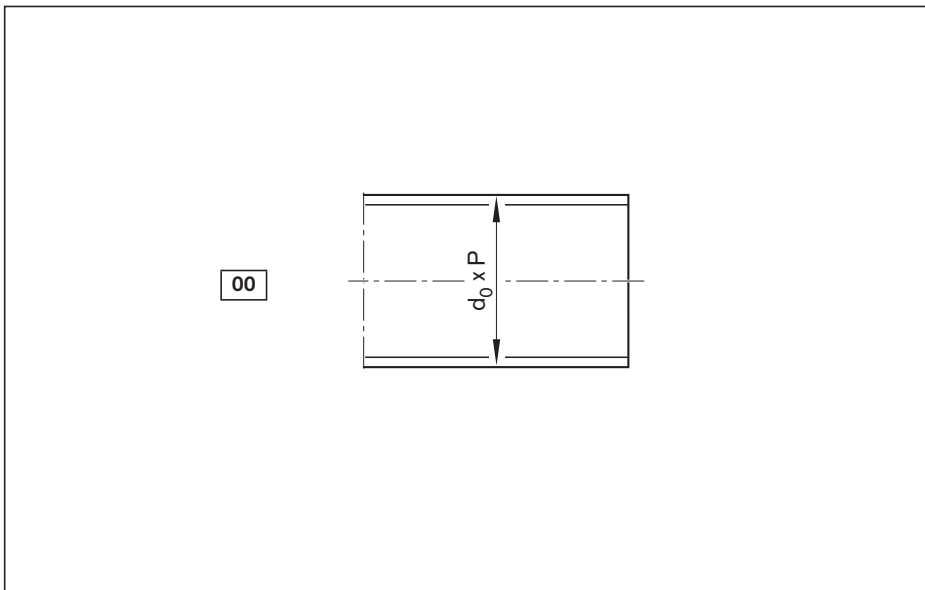

Option (machining of end face)	
K	None
Z	
S	
G	

Ordering data:

BASA	20x5R x 3	SEM-E-S - 4	00	1	2	T7	R	00Z200	82Z120	1250	0	1
------	-----------	-------------	----	---	---	----	---	--------	--------	------	---	---

Form	Version	Size		(mm)		Centering hole		Hex socket		Thread	
		d ₀	P	Z	t _z	S	t _s	G	t _g		
00	060	6	1/2	-	-	-	-	-	-	-	-
	080	8	1/2/2.5/5	-	-	-	-	-	-	-	-
	120	12	2/5/10	M3	9	4	4	M4	6	6	
	160	16	5/10/16	M4	10	5	5	M5	8	8	
	200	20	5/10/20/40	M6	16	8	8	M6	9	9	
	250	25	5/10/25	M8	19	10	10	M8	12	12	
	320	32	5/10/20/32/64	M10	22	12	12	M10	15	15	
	400	40	5/10/12/16/20/25/30/40	M12	28	14	14	M12	18	18	
	500	50	5/10/12/16/20/25/30/40	M16	36	17	17	M16	24	24	
	630	63	10/20/40	M20	42	17	17	M20	30	30	
800	80	10/20/40	M20	42	19	19	M24	36	36		

Form L1

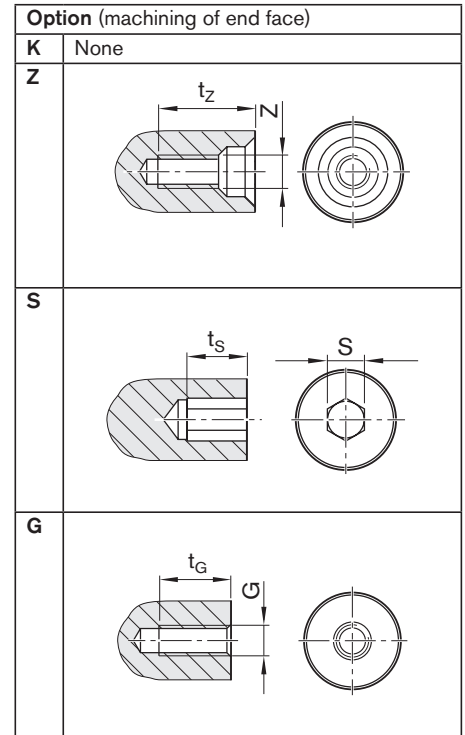
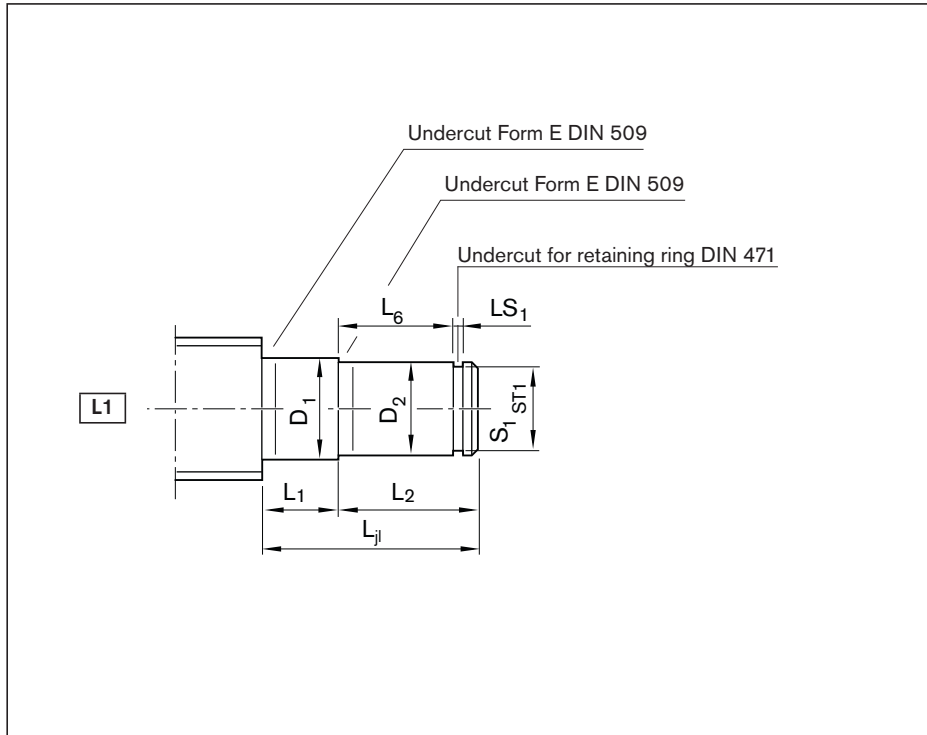

Ordering data:

BASA	20x5R x 3	SEM-E-S - 4	00	1	2	T7	R	02Z120	82Z120	1250	0	1
------	-----------	-------------	----	---	---	----	---	--------	--------	------	---	---

Form	Version ¹⁾	(mm)										
		d ₀	P	L _{ji}	D ₁ h11	L ₁	D ₂ j6	L ₂	L ₆	S ₁	S _{T1}	L _{S1} H13
L1	050	8	1/2/2.5/5	17	6.0	10	5	7	5	4.8	h10	0.70
	060	12	2/5/10	18	9.5	10	6	8	6	5.7	h10	0.80
	100	16	5/10/16	22	12.5	10	10	12	9	9.6	h10	1.10
	120	20	5/10/20/40	23	16.0	10	12	13	10	11.5	h11	1.10
	150	20	5/10/20/40	24	16.0	10	15	14	11	14.3	h11	1.10
	170	25	5/10/25	25	21.0	10	17	15	12	16.2	h11	1.10
	200	32	5/10/20/32/64	28	27.5	10	20	18	14	19.0	h11	1.30
	250	32	5/10/20/32/64	29	27.5	10	25	19	15	23.9	h12	1.30
	300	40	5/10/12/16/20/25/30/40	30	33.5	10	30	20	16	28.6	h12	1.60
	350	50	5/10/12/16/20/25/30/40	32	43.0	10	35	22	17	33.0	h12	1.60
	500	63	10/20/40	37	56.0	10	50	27	20	47.0	h12	2.15
600	80	10/20/40	39	66.5	10	60	29	22	57.0	h12	2.15	

1) The allocation of screw ends to the bearing assemblies is clearly defined by the version.

End bearings for screw ends
Form L1

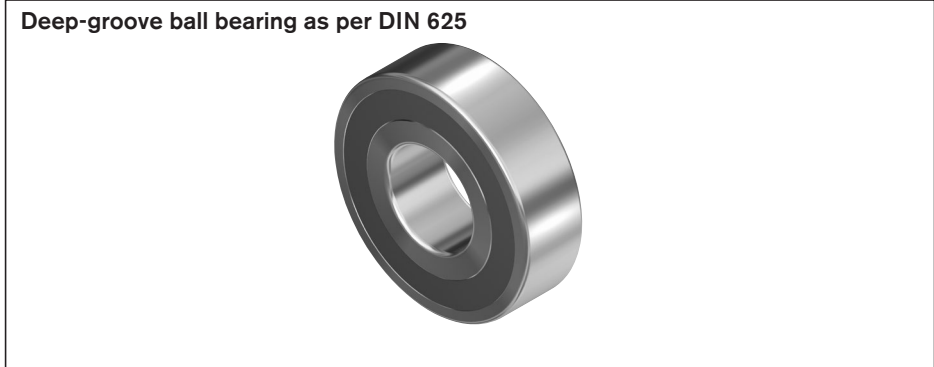

Version ¹⁾	Centering hole		Hex socket			Thread		Deep-groove ball bearing		Retaining ring	
	Z	t _z	S	t _s	G	t _g	Abbreviation	Part number	Abbreviation	Part number	
050	–	–	–	–	–	–	625.2RS	R3414 048 00	5x0.6	R3410 742 00	
060	–	–	–	–	–	–	626.2RS	R3414 043 00	10x1	R3410 736 00	
100	M3	9.0	4	4	M4	6	6200.2RS	R3414 049 00	10x1	R3410 745 00	
120	M4	10.0	4	4	M5	8	6201.2RS	R3414 042 00	12x1	R3410 712 00	
150	M5	12.5	4	4	M6	9	6202.2RS	R3414 074 00	15x1	R3410 748 00	
170	M6	16.0	5	5	M6	9	6203.2RS	R3414 050 00	17x1	R3410 749 00	
200	M6	16.0	5	5	M8	12	6204.2RS	R3414 038 00	20x1.2	R3410 735 00	
250	M10	22.0	8	8	M10	15	6205.2RS	R3414 063 00	25x1.2	R3410 750 00	
300	M10	22.0	10	10	M12	18	6206.2RS	R3414 051 00	30x1.5	R3410 724 00	
350	M12	28.0	12	12	M12	18	6207.2RS	R3414 075 00	35x1.5	R3410 725 00	
500	M16	36.0	19	19	M20	30	6210.2RS	R3414 077 00	50x2	R3410 727 00	
600	M20	42.0	19	19	M24	36	6212.2RS	R3414 078 00	60x2	R3410 764 00	

Form 02

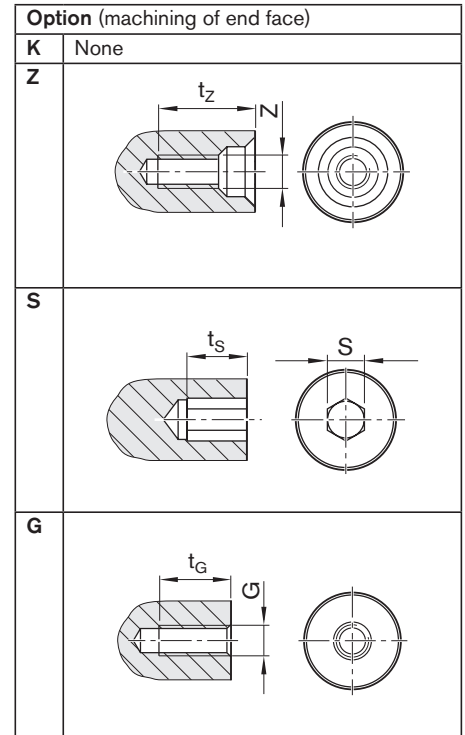
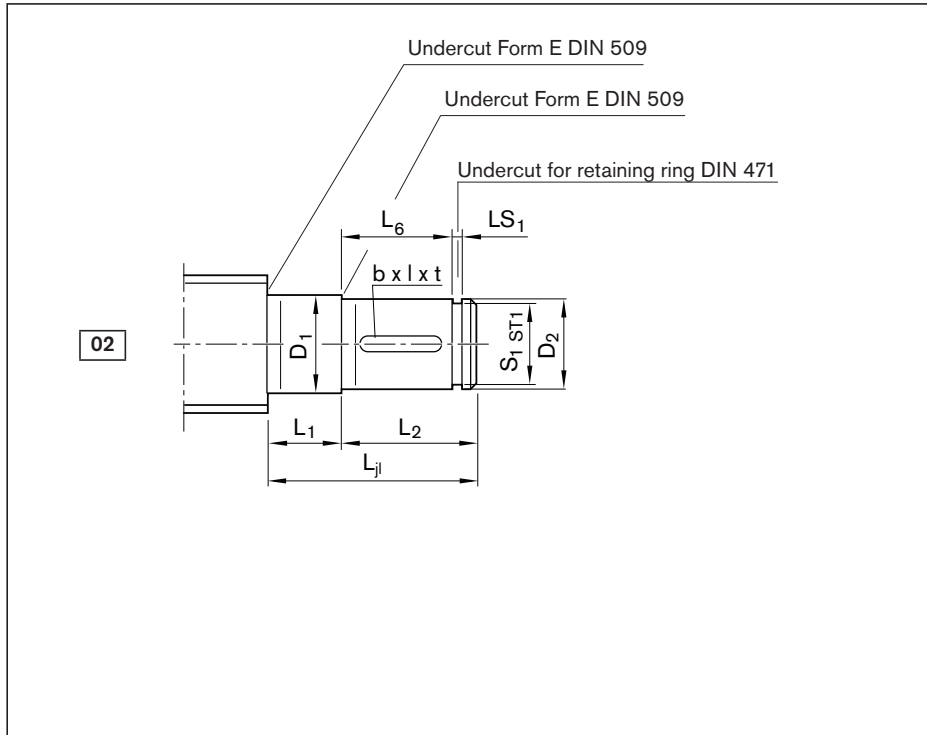

Ordering data:

BASA	20x5R x 3	SEM-E-S - 4	00	1	2	T7	R	02Z120	82Z120	1250	0	1
------	-----------	-------------	----	---	---	----	---	--------	--------	------	---	---

Form	Version ¹⁾	Size		(mm)										Keyway as per DIN 6885		
		d ₀	P	L _{ji}	D ₁ j6	L ₁	D ₂ h7	L ₂	L ₆	S ₁	ST1	LS ₁ H13	b P9	l	t	
02	100	16	5/10/16	32	10	9	8	23	20	7.6	h10	0.90	2	14	1.2	
	120	20	5/10/20/40	38	12	10	10	28	25	9.6	h10	1.10	3	20	1.8	
	150	20	5/10/20/40	39	15	11	12	28	25	11.5	h11	1.10	4	20	2.5	
	170	25	5/10/25	45	17	12	15	33	30	14.3	h11	1.10	5	25	3.0	
	200	32	5/10/20/32/64	58	20	14	18	44	40	17.0	h11	1.30	6	28	3.5	
	250	32	5/10/20/32/64	69	25	15	22	54	50	21.0	h11	1.30	6	36	3.5	
	300	40	5/10/12/16/20/25/30/40	70	30	16	28	54	50	26.6	h12	1.60	8	36	4.0	
	350	50	5/10/12/16/20/25/30/40	82	35	17	32	65	60	30.3	h12	1.60	10	40	5.0	
	500	63	10/20/40	107	50	20	48	87	80	45.5	h12	1.85	14	63	5.5	
	600	80	10/20/40	109	60	22	58	87	80	55.0	h12	2.15	16	63	6.0	

1) The allocation of screw ends to the bearing assemblies is clearly defined by the version.

**End bearings for screw ends
Form 02**

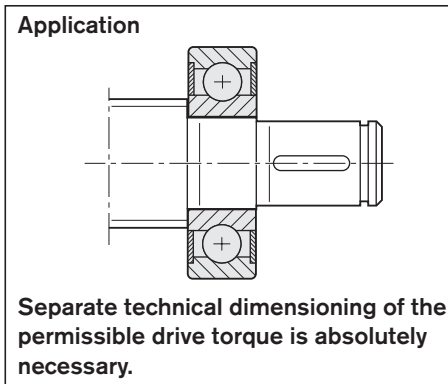
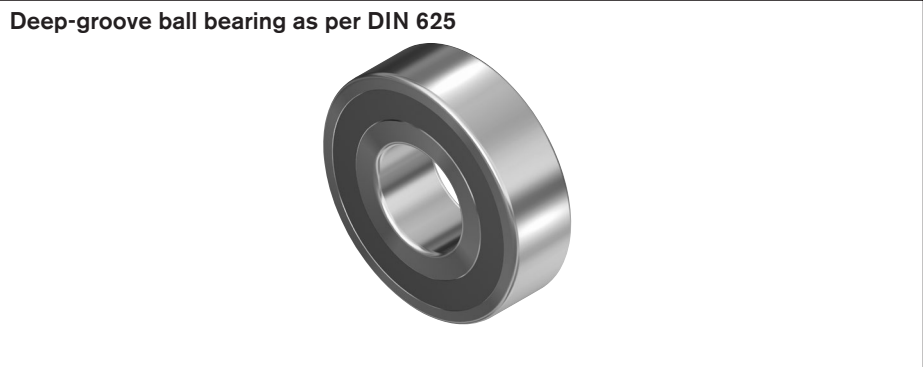

Version ¹⁾	Centering hole		Hex socket		Thread		Deep-groove ball bearing		Retaining ring	
	Z	t _Z	S	t _S	G	t _G	Abbreviation	Part number	Abbreviation	Part number
100	M3	9.0	-	-	M3	5	6200.2RS	R3414 049 00	8x0.8	R3410 737 00
120	M3	9.0	4	4	M4	6	6201.2RS	R3414 042 00	10x1	R3410 745 00
150	M4	10.0	4	4	M5	8	6202.2RS	R3414 074 00	12x1	R3410 712 00
170	M5	12.5	4	4	M6	9	6203.2RS	R3414 050 00	15x1	R3410 748 00
200	M6	16.0	5	5	M6	9	6204.2RS	R3414 038 00	18x1.2	R3410 723 00
250	M8	19.0	6	6	M8	12	6205.2RS	R3414 063 00	22x1.2	R3410 714 00
300	M10	22.0	10	10	M10	15	6206.2RS	R3414 051 00	28x1.5	R3410 752 00
350	M12	28.0	10	10	M12	18	6207.2RS	R3414 075 00	32x1.5	R3410 753 00
500	M16	36.0	17	17	M16	24	6210.2RS	R3414 077 00	48x1.75	R3410 718 00
600	M20	42.0	19	19	M20	30	6212.2RS	R3414 078 00	58x2	R3410 728 00

Form K1, K1A

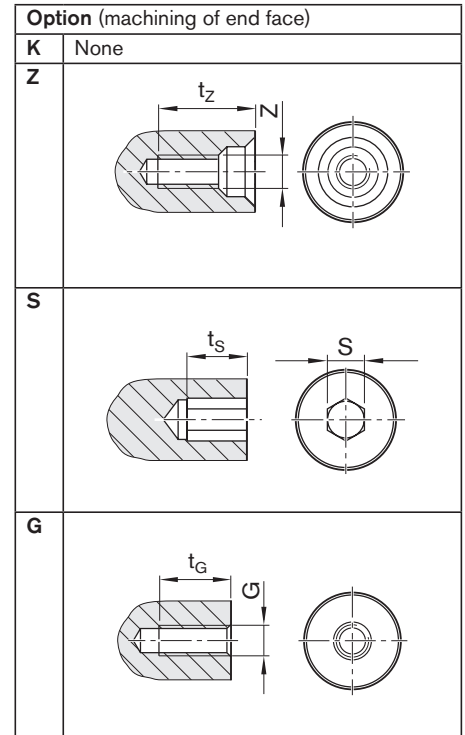
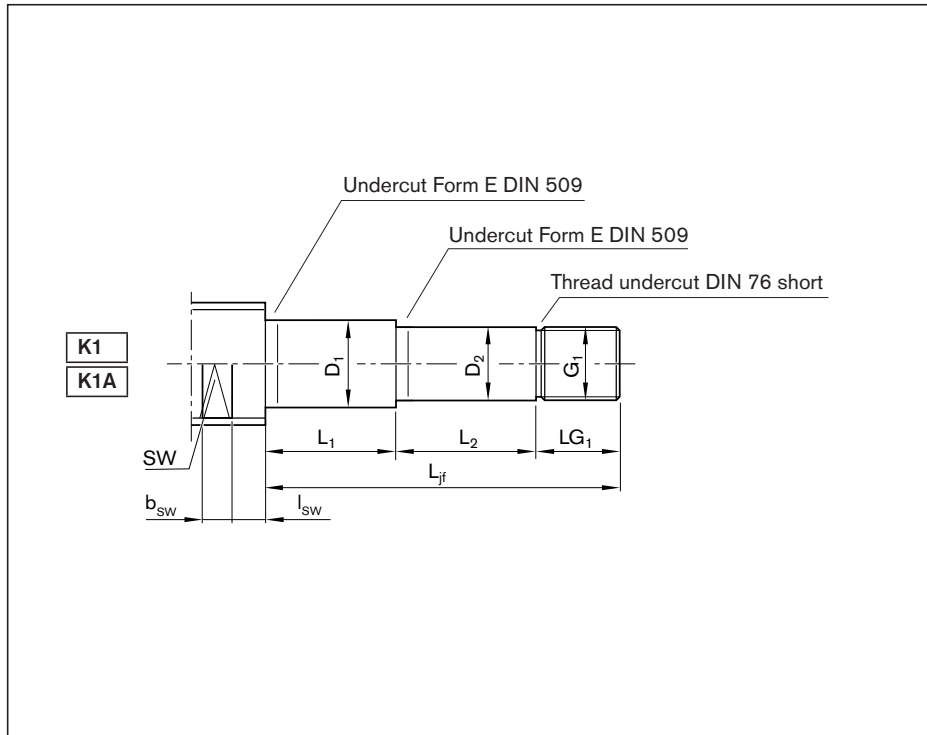

Ordering data:

BASA	20x5R x 3	SEM-E-S - 4	00	1	2	T7	R	K1AZ120	41Z120	1250	0	1
------	-----------	-------------	----	---	---	----	---	---------	--------	------	---	---

Form	Version ¹⁾	Size		(mm)								Centering hole		Hex socket	
		d ₀	P	L _{jf}	D ₁ h11	L ₁ h6	D ₂	L ₂	G ₁	L _{G1}	Z	t _z	S	t _s	
K1/K1A	100	16	5/10/16	40	12.5	10	10	18	M10x1	12	M3	9.0	4	4	
	120	20	5/10/20/40	45	16.0	10	12	23	M12x1	12	M4	10.0	4	4	
	170	25	5/10/25	55	21.0	10	17	23	M17x1	22	M6	16.0	5	5	
	200	32	5/10/20/32/64	58	27.5	10	20	26	M20x1	22	M6	16.0	5	5	
	250	40	5/10/12/16/20/25/30/40	90	33.5	10	25	54	M25x1.5	26	M10	22.0	8	8	
	300	40	5/10/12/16/20/25/30/40	61	33.5	10	30	25	M30x1.5	26	M10	22.0	10	10	
	301	50	5/10/12/16/20/25/30/40	90	43.0	10	30	54	M30x1.5	26	M10	22.0	10	10	
	350	50	5	70	45.0	10	35	32	M35x1.5	28	M12	28.0	12	12	
	400	63	10/20/40	82	56.0	10	40	44	M40x1.5	28	M16	36.0	12	12	
	500	80	10/20/40	94	66.5	10	50	52	M50x1.5	32	M16	36.0	19	19	

1) The allocation of screw ends to the bearing assemblies is clearly defined by the version.

End bearings for screw ends
Form K1, K1A



Version ¹⁾	Thread		Wrench size			Angular-contact thrust ball bearing				Slotted nut	
						LGF		LGN		NMZ/NMA	
	G	t _g	SW	b _{sw}	l _{sw}	Abbreviation	Part number	Abbreviation	Part number	Abbreviation	Part number
100	M4	6	11	10	8.5	–	–	LGN-B-1034	R3414 003 06	NMZ 10x1	R3446 002 04
120	M5	8	15	10	8.5	LGF-B-1255	R3414 009 06	LGN-B-1242	R3414 004 06	NMZ 12x1	R3446 003 04
170	M6	9	19	10	10.5	LGF-B-1762	R3414 010 06	LGN-B-1747	R3414 005 06	NMA 17x1	R3446 014 04
200	M8	12	24	15	10.5	LGF-B-2068	R3414 001 06	LGN-B-2052	R3414 006 06	NMA 20x1	R3446 015 04
250	M10	15	30	15	12.5	LGF-C-2575	R3414 015 06	LGN-C-2557	R3414 014 06	NMA 25x1.5	R3446 011 04
300	M12	18	30	15	12.5	LGF-B-3080	R3414 011 06	LGN-B-3062	R3414 007 06	NMA 30x1.5	R3446 016 04
301	M12	18	41	22	15.5	LGF-C-3080	R3414 027 06	LGN-C-3062	R3414 023 06	NMA 30x1.5	R3446 016 04
350	M12	18	41	22	15.5	LGF-B-3590	R3414 026 06	LGN-B-3572	R3414 022 06	NMA 35x1.5	R3446 012 04
400	M16	24	50	27	16.5	LGF-B-40115	R3414 028 06	LGN-A-4090	R3414 024 06	NMA 40x1.5	R3446 018 04
500	M20	30	60	27	18.5	LGF-A-50140	R3414 029 06	LGN-A-50110	R3414 025 06	NMA 50x1.5	R3446 019 04

Form 12, 12A

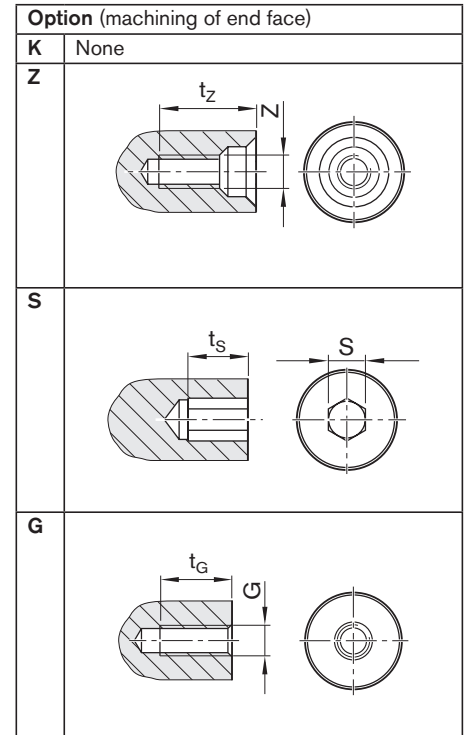
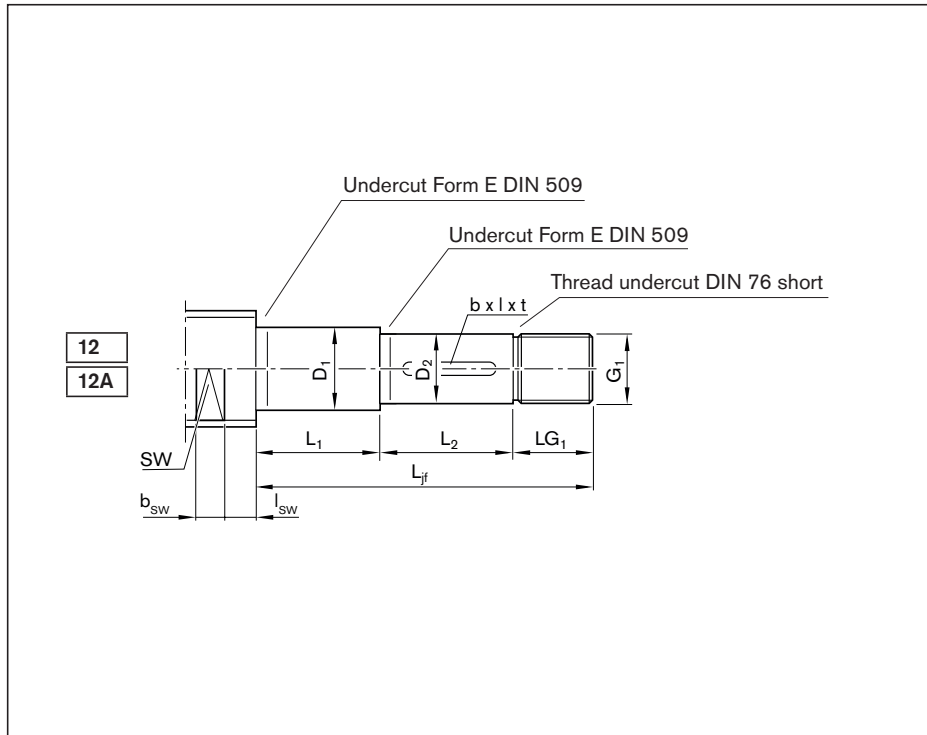

Ordering data:

BASA	20x5R x 3	SEM-E-S - 4	00	1	2	T7	R	K1AZ120	41Z120	1250	0	1
------	-----------	-------------	----	---	---	----	---	---------	--------	------	---	---

Form	Version ¹⁾	Size		(mm)								Keyway as per DIN 6885			Centering hole		Hex socket	
		d ₀	P	L _{ff}	D ₁ h6	L ₁	D ₂ h7	L ₂	G ₁	LG ₁	b P9	l	t	Z	t _z	S	t _s	
12/12A	100	16	5/10/16	48	10	18	8	20	M6x0.5	10	2	14	1.2	-	-	-	-	
	120	20	5/10/20/40	60	12	23	10	25	M10x1	12	3	20	1.8	M3	9.0	4	4	
	170	25	5/10/25	75	17	23	15	30	M15x1	22	5	25	3.0	M5	12.5	4	4	
	200	32	5/10/20/32/64	88	20	26	18	40	M17x1	22	6	28	3.5	M6	16.0	5	5	
	250	40	5/10/12/16/20/25/30/40	126	25	54	22	50	M20x1	22	6	36	3.5	M6	16.0	5	5	
	300	40	5/10/12/16/20/25/30/40	101	30	25	28	50	M25x1.5	26	8	36	4.0	M10	22.0	8	8	
	301	50	5/10/12/16/20/25/30/40	130	30	54	28	50	M25x1.5	26	8	36	4.0	M10	22.0	8	8	
	350	50	5	118	35	32	32	60	M30x1.5	26	10	40	5.0	M10	22.0	10	10	
	400	63	10/20/40	132	40	44	38	60	M35x1.5	28	10	40	5.0	M12	28.0	12	12	
	500	80	10/20/40	160	50	52	48	80	M40x1.5	28	14	63	5.5	M16	36.0	12	12	

1) The allocation of screw ends to the bearing assemblies is clearly defined by the version.

End bearings for screw ends
Form 12, 12A

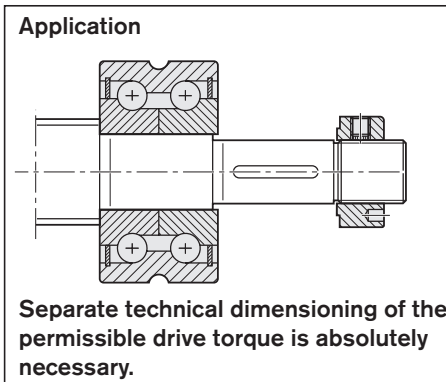

Version ¹⁾	Thread		Wrench size			Angular-contact thrust ball bearing				Slotted nut	
	G	t _G	SW	b _{SW}	l _{SW}	LGF		LGN		NMZ/NMA	
						Abbreviation	Part number	Abbreviation	Part number	Abbreviation	Part number
100	-	-	11	10	8.5	-	-	LGN-B-1034	R3414 003 06	NMZ6x0.5	R3446 001 04
120	M4	6	15	10	8.5	LGF-B-1255	R3414 009 06	LGN-B-1242	R3414 004 06	NMZ10x1	R3446 002 04
170	M6	9	19	10	10.5	LGF-B-1762	R3414 010 06	LGN-B-1747	R3414 005 06	NMA15x1	R3446 020 04
200	M6	9	24	15	10.5	LGF-B-2068	R3414 001 06	LGN-B-2052	R3414 006 06	NMA17x1	R3446 014 04
250	M8	12	30	15	12.5	LGF-B-2575	R3414 015 06	LGN-C-2557	R3414 014 06	NMA20x1	R3446 015 04
300	M10	15	30	15	12.5	LGF-B-3080	R3414 011 06	LGN-B-3062	R3414 007 06	NMA25x1.5	R3446 011 04
301	M10	15	41	22	15.5	LGF-C-3080	R3414 027 06	LGN-C-3062	R3414 023 06	NMA25x1.5	R3446 011 04
350	M12	18	41	22	15.5	LGF-B-3590	R3414 026 06	LGN-B-3572	R3414 022 06	NMA30x1.5	R3446 016 04
400	M12	18	50	27	16.5	LGF-B-40115	R3414 028 06	LGN-A-4090	R3414 024 06	NMA35x1.5	R3446 012 04
500	M16	24	60	27	18.5	LGF-A-50140	R3414 029 06	LGN-A-50110	R3414 025 06	NMA40x1.5	R3446 018 04

Form 21, 22

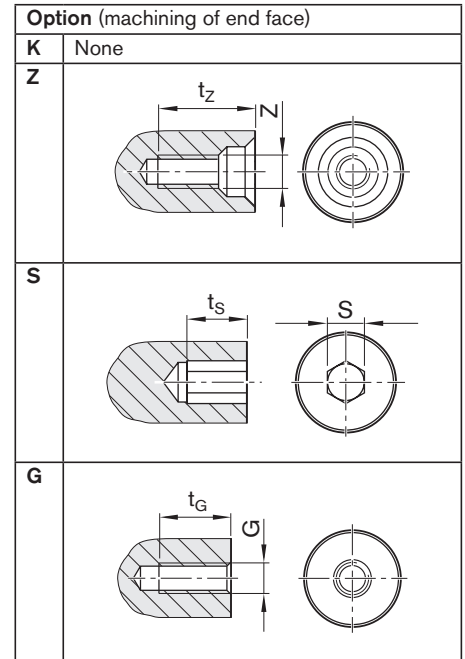
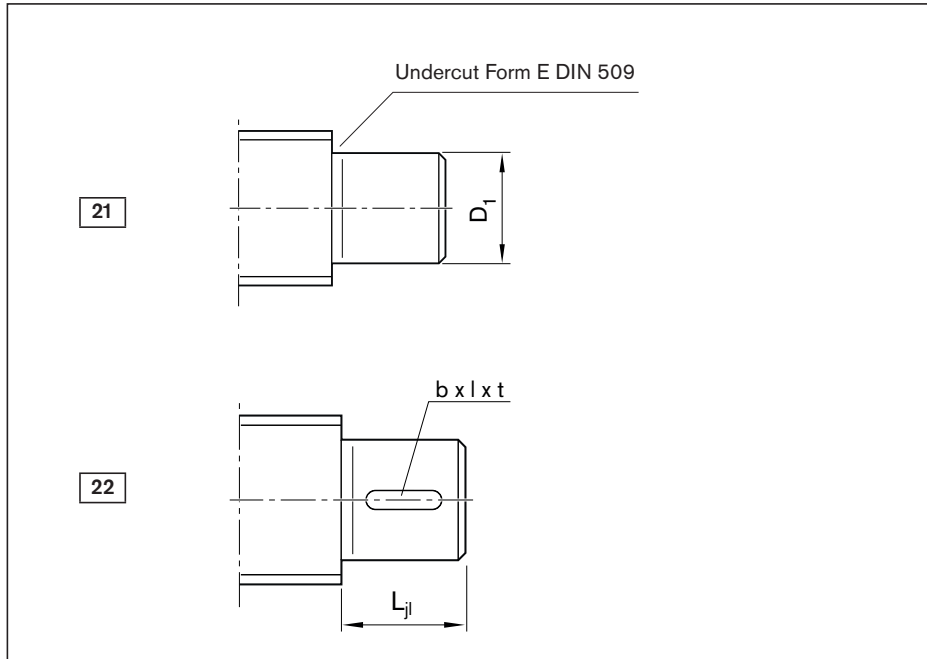

Ordering data:

BASA	20x5R x 3	SEM-E-S - 4	00	1	2	T7	R	21Z120	82Z120	1250	0	1
------	-----------	-------------	----	---	---	----	---	--------	--------	------	---	---

Form	Version ¹⁾	Size		(mm)		Keyway as per DIN 6885			Centering hole	
		d_0	P	L_{jl}	D_1 j6	b P9	l	t	Z	t_z
21	050	8	1/2/2.5/5	5	5	-	-	-	-	-
	060	12	2/5/10	6	6	-	-	-	-	-
	100	16	5/10/16	9	10	-	-	-	M3	9.0
	120	20	5/10/20/40	10	12	-	-	-	M4	10.0
	150	20	5/10/20/40	11	15	-	-	-	M5	12.5
	170	25	5/10/25	12	17	-	-	-	M6	16.0
	200	32	5/10/20/32/64	14	20	-	-	-	M6	16.0
	250	32	5/10/20/32/64	15	25	-	-	-	M10	22.0
	300	40	5/10/12/16/20/25/30/40	16	30	-	-	-	M10	22.0
	350	50	5/10/12/16/20/25/30/40	17	35	-	-	-	M12	28.0
500	63	10/20/40	20	50	-	-	-	M16	36.0	
600	80	10/20	22	60	-	-	-	M20	42.0	
22	100	16	5/10/16	11	10	3	6	1.8	M3	9.0
	120	20	5/10/20/40	13	12	4	8	2.5	M4	10.0
	150	20	5/10/20/40	15	15	5	10	3.0	M5	12.5
	170	25	5/10/25	15	17	5	10	3.0	M6	16.0
	200	32	5/10/20/32/64	24	20	6	14	3.5	M6	16.0
	250	32	5/10/20/32/64	28	25	8	18	4.0	M10	22.0
	300	40	5/10/12/16/20/25/30/40	28	30	8	18	4.0	M10	22.0
	350	50	5/10/12/16/20/25/30/40	32	35	10	22	5.0	M12	28.0
	500	63	10/20/40	46	50	14	36	5.5	M16	36.0
	600	80	10/20/40	60	60	18	50	7.0	M20	42.0

1) The allocation of screw ends to the bearing assemblies is clearly defined by the version.

End bearings for screw ends in Form 21

Application

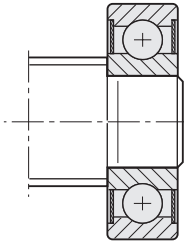

Separate technical dimensioning of the permissible drive torque is absolutely necessary.

Bearing assembly LAD²⁾



Version ¹⁾	Hex socket S	t _s	Thread G	t _G	Bearing assembly (deep-groove ball bearing as per DIN 625) LAD	
					Abbreviation	Part number
050	–	–	–	–	625.2RS	R3414 048 00
060	–	–	–	–	626.2RS	R3414 043 00
100	4	4	M4	6	6200.2RS	R3414 049 00
120	4	4	M5	8	6201.2RS	R3414 042 00
150	4	4	M6	9	6202.2RS	R3414 074 00
170	5	5	M6	9	6203.2RS	R3414 050 00
200	5	5	M8	12	6204.2RS	R3414 038 00
250	8	8	M10	15	6205.2RS	R3414 063 00
300	10	10	M12	18	6206.2RS	R3414 051 00
350	12	12	M12	18	6207.2RS	R3414 075 00
500	19	19	M20	30	6210.2RS	R3414 077 00
600	19	19	M24	36	6212.2RS	R3414 078 00
100	4	4	M4	6	–	–
120	4	4	M5	8	–	–
150	4	4	M6	9	–	–
170	5	5	M6	9	–	–
200	5	5	M8	12	–	–
250	8	8	M10	15	–	–
300	10	10	M12	18	–	–
350	12	12	M12	18	–	–
500	19	19	M20	30	–	–
600	19	19	M24	36	–	–

2) Scope of delivery: 1 bearing, 2 retaining rings.

Form 31

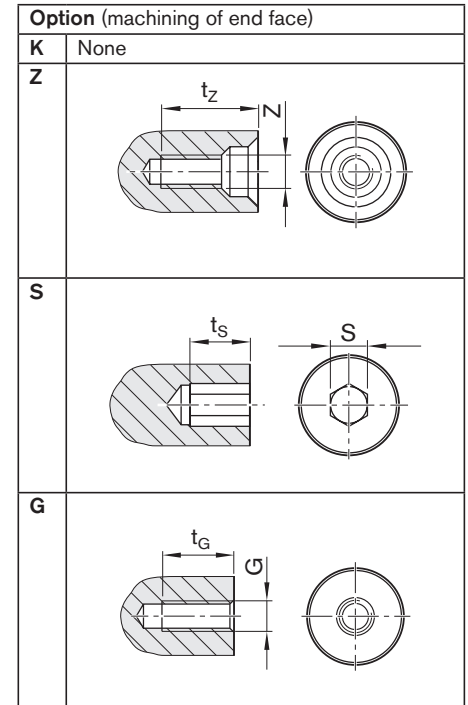
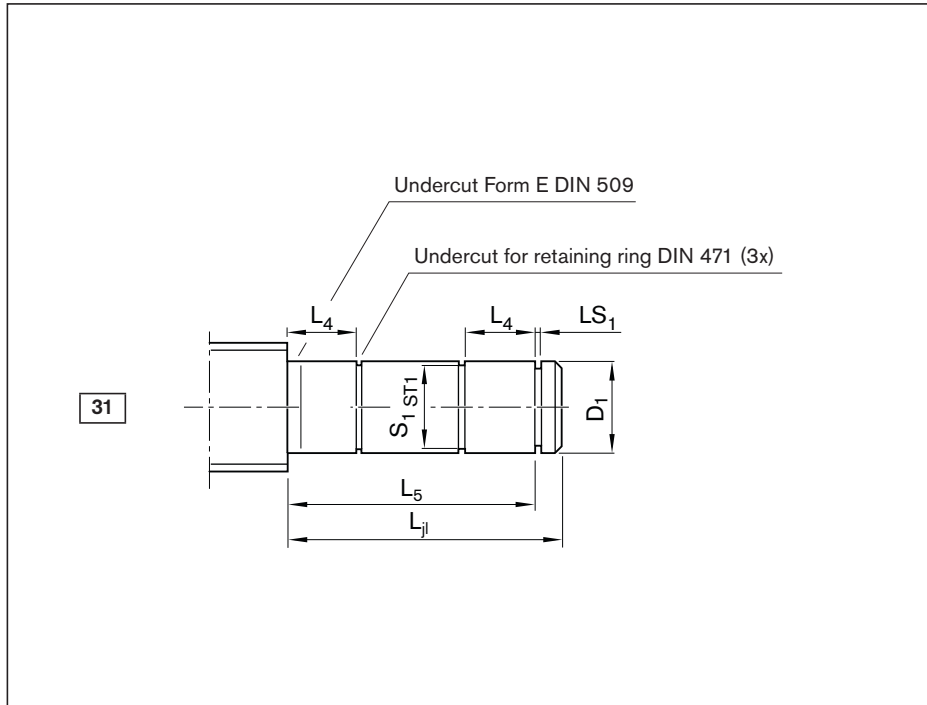

Ordering data:

BASA	20x5R x 3	SEM-E-S - 4	00	1	2	T7	R	31Z120	82Z120	1250	0	1
------	-----------	-------------	----	---	---	----	---	--------	--------	------	---	---

Form	Version ¹⁾	Size		(mm)							Centering hole	
		d_0	P	L_{ij}	D_1 j6	L_4	L_5	S_1	ST1	LS_1 H13	Z	t_z
31	050	8	1/2/2.5/5	22	5	5	20	4.8	h10	0.70	-	-
	060	12	2/5/10	26	6	6	24	5.7	h10	0.80	-	-
	100	16	5/10/16	39	10	9	36	9.6	h10	1.10	M3	9.0
	120	20	5/10/20/40	43	12	10	40	11.5	h11	1.10	M4	10.0
	150	20	5/10/20/40	47	15	11	44	14.3	h11	1.10	M5	12.5
	170	25	5/10/25	51	17	12	48	16.2	h11	1.10	M6	16.0
	200	32	5/10/20/32/64	60	20	14	56	19.0	h11	1.30	M6	16.0
	250	32	5/10/20/32/64	64	25	15	60	23.9	h12	1.30	M10	22.0
	300	40	5/10/12/16/20/25/30/40	68	30	16	64	28.6	h12	1.60	M10	22.0
	350	50	5/10/12/16/20/25/30/40	73	35	17	68	33.0	h12	1.60	M12	28.0
	500	63	10/20/40	87	50	20	80	47.0	h12	2.15	M16	36.0
600	80	10/20/40	95	60	22	88	57.0	h12	2.15	M20	42.0	

1) The allocation of screw ends to the bearing assemblies is clearly defined by the version.
Note: Form 31 with double floating bearing increases the critical speed, n_{cr} . See "Critical speed n_{cr} " on page 174.

**End bearings
for screw ends in Form 31**

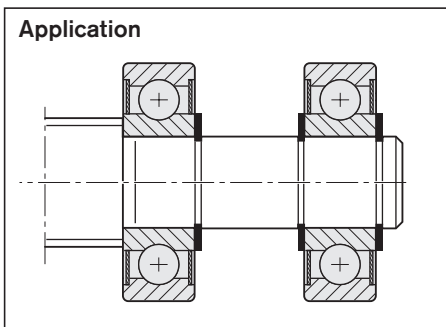
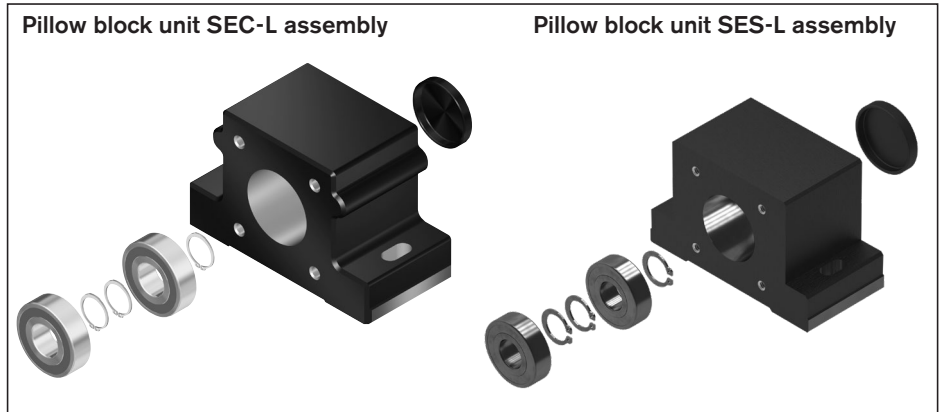

Version ¹⁾	Hex socket		Thread G	t _G	Module Pillow block unit		Bearing LAD ²⁾ Part number
	S	t _S			SEC-L Part number	SES-L Part number	
050	-	-	-	-	-	-	R1590 605 00
060	-	-	-	-	-	-	R1590 606 00
100	4	4	M4	6	-	-	R1590 610 00
120	4	4	M5	8	-	-	R1590 612 00
150	4	4	M6	9	R1594 615 00	R1595 615 00	R1590 615 00
170	5	5	M6	9	-	R1595 617 00	R1590 617 00
200	5	5	M8	12	R1594 620 00	R1595 620 00	R1590 620 00
250	8	8	M10	15	-	-	R1590 625 00
300	10	10	M12	18	R1594 630 00	R1595 630 00	R1590 630 00
350	12	12	M12	18	-	-	R1590 635 00
500	19	19	M20	30	-	-	R1590 650 00
600	19	19	M24	36	-	-	R1590 660 00

2) Items delivered per bearing LAD: 1 bearing, 2 retaining rings. For application with form 31: 2x assemblies required.

Form 41

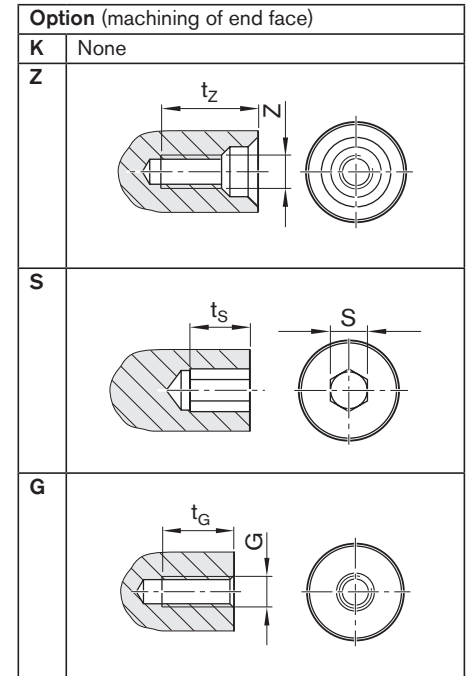
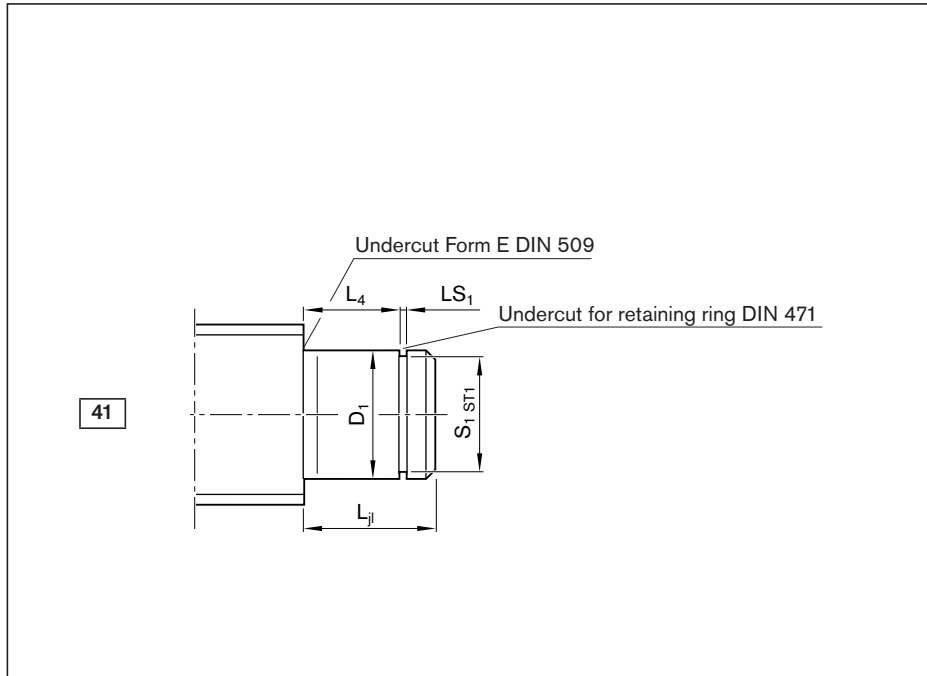

Ordering data:

BASA	20x5R x 3	SEM-E-S - 4	00	1	2	T7	R	41Z120	82Z120	1250	0	1
------	-----------	-------------	----	---	---	----	---	--------	--------	------	---	---

Form	Version ¹⁾	Size		(mm)							Centering hole	
		d_0	P	L_{ji}	D_1	L_4	S_1	ST1	LS_1	Z	t_z	
41	050	8	1/2/2.5/5	7	5	5	4.8	h10	0.70	–	–	
	060	12	2/5/10	8	6	6	5.7	h10	0.80	–	–	
	100	16	5/10/16	12	10	9	9.6	h10	1.10	M3	9.0	
	120	20	5/10/20/40	13	12	10	11.5	h11	1.10	M4	10.0	
	150	20	5/10/20/40	14	15	11	14.3	h11	1.10	M5	12.5	
	151	20	5/10/20/40	14	15	9	14.3	h11	1.10	M5	12.5	
	170	25	5/10/25	15	17	12	16.2	h11	1.10	M6	16.0	
	200	32	5/10/20/32/64	18	20	14	19.0	h11	1.30	M6	16.0	
	202	25	5/10/25	19	20	14	19.0	h11	1.30	M6	16.0	
	250	32	5/10/20/32/64	19	25	15	23.9	h12	1.30	M10	22.0	
	252	32	5/10/20/32/64	20	25	15	23.9	h12	1.30	M10	22.0	
	300	40	5/10/12/16/20/25/30/40	20	30	16	28.6	h12	1.60	M10	22.0	
	350	50	5/10/12/16/20/25/30/40	22	35	17	33.0	h12	1.60	M12	28.0	
	500	63	10/20/40	27	50	20	47.0	h12	2.15	M16	36.0	
600	80	10/20/40	29	60	22	57.0	h12	2.15	M20	42.0		

1) The allocation of screw ends to the bearing assemblies is clearly defined by the version.

**End bearings
for screw ends in Form 41**

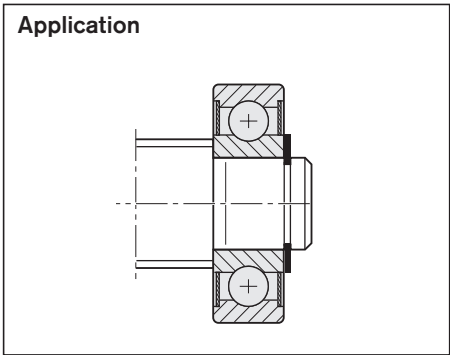
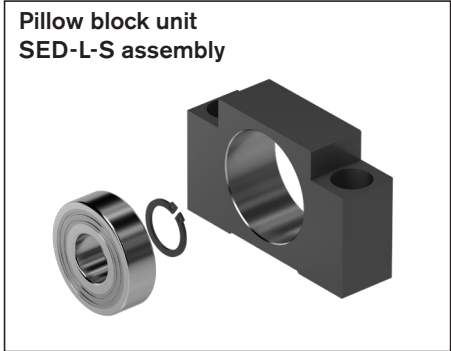
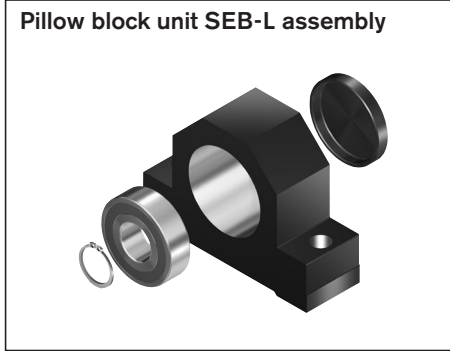

Version ¹⁾	Hex socket S	t _S	Thread G	t _G	Bearing assembly LAD ²⁾ Part number	Pillow block unit SEB-L Part number	Pillow block unit SED-L-S Part number
050	–	–	–	–	R1590 605 00	R1591 605 00	–
060	–	–	–	–	R1590 606 00	R1591 606 20	–
100	4	4	M4	6	R1590 610 00	R1591 610 20	–
120	4	4	M5	8	R1590 612 00	R1591 612 20	–
150	4	4	M6	9	R1590 615 00	–	–
151	4	4	M6	9	–	–	R1596 615 00
170	5	5	M6	9	R1590 617 00	R1591 617 20	–
200	5	5	M8	12	R1590 620 00	R1591 620 20	–
202	5	5	M8	12	–	–	R1596 620 00
250	8	8	M10	15	R1590 625 00	–	–
252	8	8	M10	15	–	–	R1596 625 00
300	10	10	M12	18	R1590 630 00	R1591 630 20	–
350	12	12	M12	18	R1590 635 00	R1591 635 20	–
500	19	19	M20	30	R1590 650 00	R1591 650 20	–
600	19	19	M24	36	R1590 660 00	R1591 660 20	–

2) Scope of delivery: 1 bearing, 2 retaining rings.

Form 51, 51A, 52, 52A

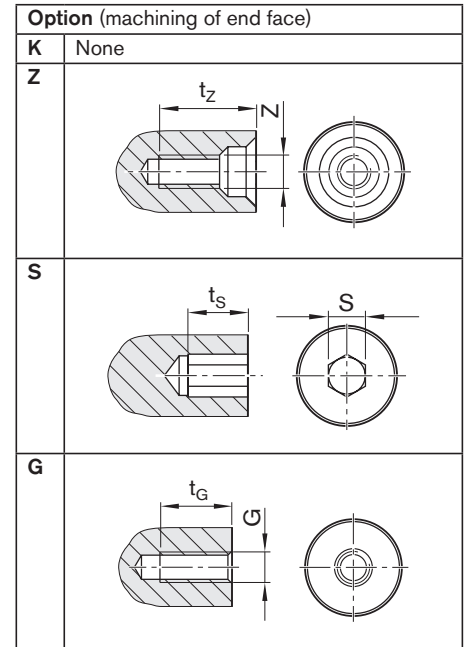
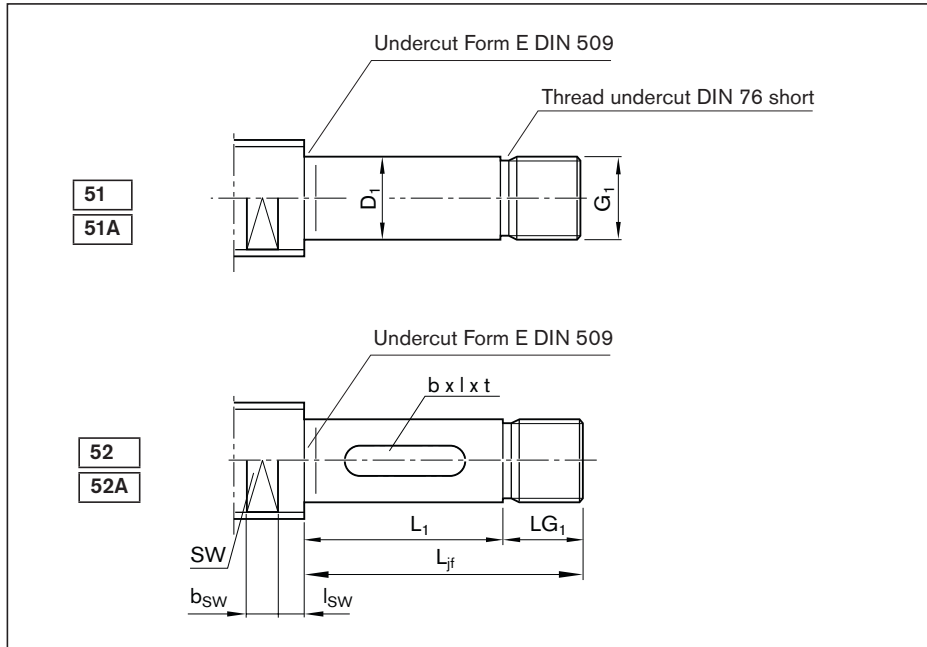

Ordering data:

BASA	20x5R x 3	SEM-E-S - 4	00	1	2	T7	R	52AZ120	82Z120	1250	0	1
------	-----------	-------------	----	---	---	----	---	---------	--------	------	---	---

Form	Version ¹⁾	Size		(mm)						Keyway as per DIN 6885		
		d ₀	P	L _{jf}	D ₁ h6	L ₁	G ₁	LG ₁	b P9	l	t	
51/51A	060	12	2/5/10	24	6	14	M6x0.5	10	-	-	-	
	100	16	5/10/16	30	10	18	M10x1	12	-	-	-	
	120	20	5/10/20/40	35	12	23	M12x1	12	-	-	-	
	170	25	5/10/25	45	17	23	M17x1	22	-	-	-	
	200	32	5/10/20/32/64	48	20	26	M20x1	22	-	-	-	
	209	32	5/10/20/32/64	108	20	77	M20x1	31	-	-	-	
	250	40	5/10/12/16/20/25/30/40	80	25	54	M25x1.5	26	-	-	-	
	300	40	5/10/12/16/20/25/30/40	51	30	25	M30x1.5	26	-	-	-	
	301	50	5/10/12/16/20/25/30/40	80	30	54	M30x1.5	26	-	-	-	
	309	40	5/10/12/16/20/25/30/40	117	30	83	M30x1.5	34	-	-	-	
	350	50	5	60	35	32	M35x1.5	28	-	-	-	
	359	50	5/10/20/30/40	145	35	109	M35x1.5	36	-	-	-	
	400	63	10/20/40	72	40	44	M40x1.5	28	-	-	-	
	409	63	10/20/40	183	40	147	M40x1.5	36	-	-	-	
500	80	10/20/40	84	50	52	M50x1.5	32	-	-	-		
52/52A	080	12	2/5/10	30	8	20	M8x0.75	10	2	14	1.2	
	100	16	5/10/16	37	10	25	M10x1	12	3	20	1.8	
	120	20	5/10/20/40	37	12	25	M12x1	12	4	20	2.5	
	170	25	5/10/25	52	17	30	M17x1	22	5	25	3.0	
	200	32	5/10/20/32/64	62	20	40	M20x1	22	6	28	3.5	
	250	40	5/10/12/16/20/25/30/40	76	25	50	M25x1.5	26	8	36	4.0	
	300	40	5/10/12/16/20/25/30/40	76	30	50	M30x1.5	26	8	36	4.0	
	350	50	5/10/12/16/20/25/40	78	35	50	M35x1.5	28	10	40	5.0	
	400	63	10/20/40	88	40	60	M40x1.5	28	12	50	5.0	
	500	80	10/20/40	112	50	80	M50x1.5	32	14	63	5.5	

1) The allocation of screw ends to the bearing assemblies is clearly defined by the version.

**End bearings
for screw ends Form
51, 51A**

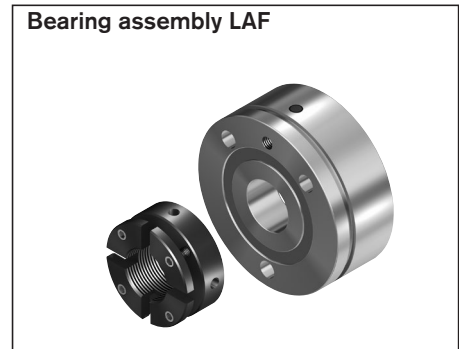
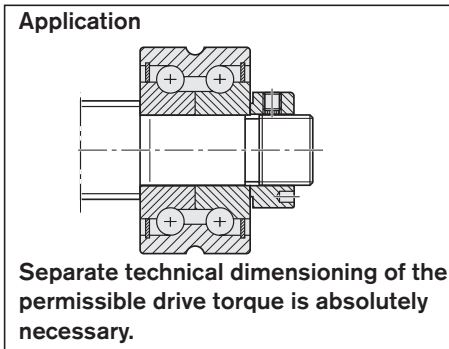
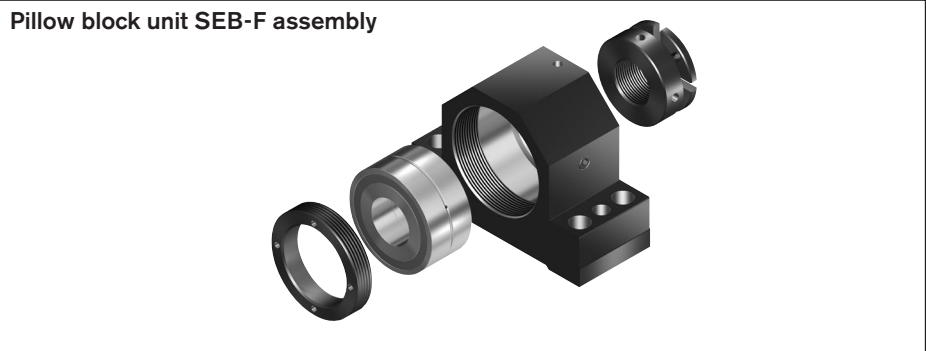

Ball screw assemblies BASA

Version ¹⁾	Centering hole		Hex socket		Thread		Wrench size			Module		
	Z	tz	S	t _s	G	t _G	SW	bSW	ISW	Pillow block unit SEB-F Part number	Bearing LAF Part number	Bearing LAN Part number
060	-	-	-	-	-	-	9	10	8.5	R1591 106 20	-	R1590 106 00
100	M3	9	4	4	M4	6	11	10	8.5	R1591 110 20	-	R1590 110 00
120	M4	10	4	4	M5	8	15	10	8.5	R1591 112 20	R1590 012 00	R1590 112 00
170	M6	16	5	5	M6	9	19	10	10.5	R1591 117 30	R1590 017 30	R1590 117 30
200	M6	16	5	5	M8	12	24	15	10.5	R1591 120 30	R1590 020 30	R1590 120 30
209	M6	16	5	5	M8	12	24	15	10.5	-	-	-
250	M10	22	8	8	M10	15	30	15	12.5	R1591 225 30	R1590 325 30	R1590 225 30
300	M10	22	10	10	M12	18	30	15	12.5	R1591 130 30	R1590 030 30	R1590 130 30
301	M10	22	10	10	M12	18	41	22	15.5	R1591 230 30	R1590 330 30	R1590 230 30
309	M10	22	10	10	M12	18	30	15	12.5	-	-	-
350	M12	28	12	12	M12	18	41	22	15.5	R1591 135 30	R1590 035 30	R1590 135 30
359	M12	28	12	12	M12	18	41	22	15.5	-	-	-
400	M16	36	12	12	M16	24	50	27	16.5	R1591 140 30	R1590 040 30	R1590 140 30
409	M16	36	12	12	M16	24	50	27	16.5	-	-	-
500	M16	36	19	19	M20	30	60	27	18.5	R1591 150 30	R1590 050 30	R1590 150 30
080	M3	9	-	-	M3	5	9	10	8.5	-	-	-
100	M3	9	4	4	M4	6	11	10	8.5	-	-	-
120	M4	10	4	4	M5	8	15	10	8.5	-	-	-
170	M6	16	5	5	M6	9	19	10	10.5	-	-	-
200	M6	16	5	5	M8	12	24	15	10.5	-	-	-
250	M10	22	8	8	M10	15	30	15	12.5	-	-	-
300	M10	22	10	10	M12	18	30	15	12.5	-	-	-
350	M12	28	12	12	M12	18	41	22	15.5	-	-	-
400	M16	36	12	12	M16	24	50	27	16.5	-	-	-
500	M16	36	19	19	M20	30	60	27	18.5	-	-	-

Form 61, 62

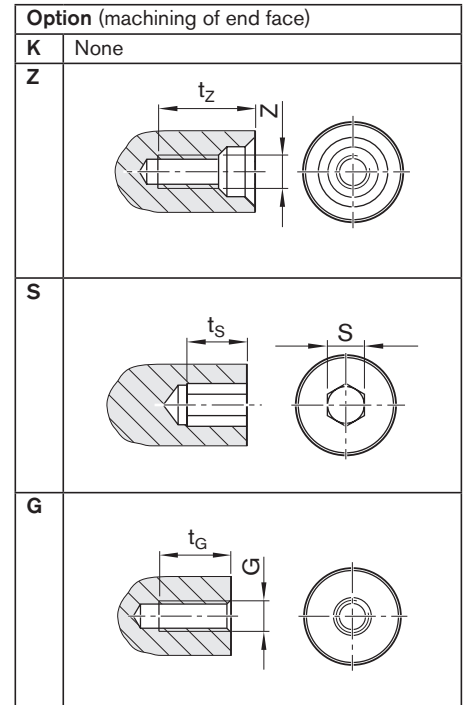
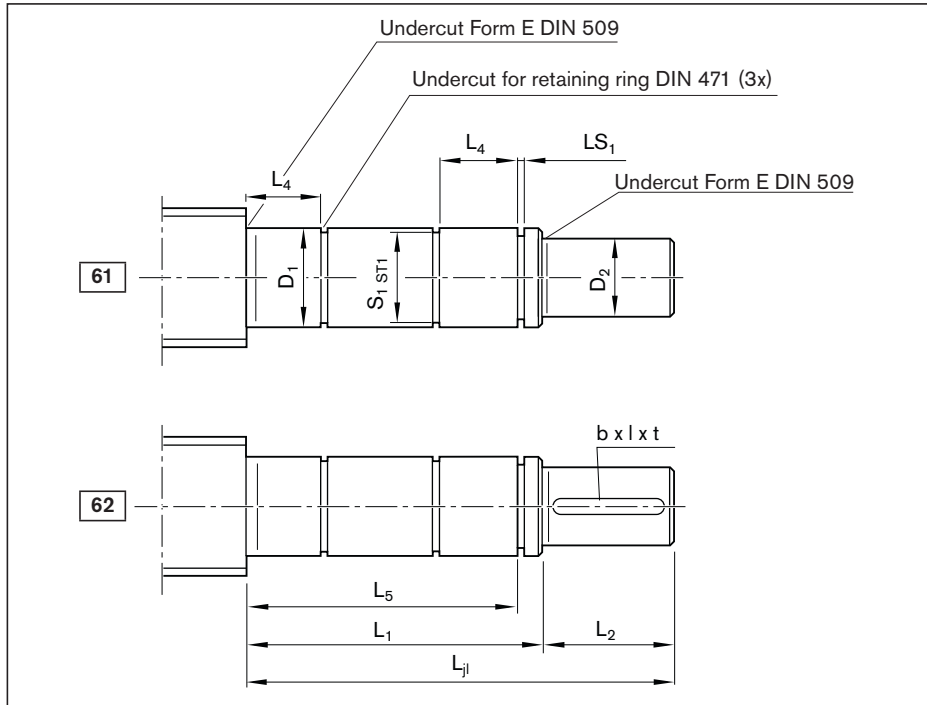

Ordering data:

BASA 20x5R x 3 SEM-E-S - 4 00 1 2 T7 R 62Z120 51Z120 1250 0 1

Form	Version ¹⁾	Size		(mm)										
		d ₀	P	L _{jl}	D ₁ j6	L ₁	D ₂ h7	L ₂	L ₄	L ₅	S ₁	ST1	LS ₁ H13	
61	050	8	1/2/2.5/5	34	5	22	4	12	5	20	4.8	h10	0.70	
	060	12	2/5/10	42	6	26	5	16	6	24	5.7	h10	0.80	
	100	16	5/10/16	59	10	39	8	20	9	36	9.6	h10	1.10	
	120	20	5/10/20/40	68	12	43	10	25	10	40	11.5	h11	1.10	
	150	20	5/10/20/40	72	15	47	12	25	11	44	14.3	h11	1.10	
	170	25	5/10/25	81	17	51	15	30	12	48	16.2	h11	1.10	
	200	32	5/10/20/32/64	100	20	60	18	40	14	56	19.0	h11	1.30	
	250	32	5/10/20/32/64	114	25	64	22	50	15	60	23.9	h12	1.30	
	300	40	5/10/12/16/20/25/30/40	118	30	68	28	50	16	64	28.6	h12	1.60	
	350	50	5/10/12/16/20/25/30/40	133	35	73	32	60	17	68	33.0	h12	1.60	
	500	63	10/20/40	167	50	87	48	80	20	80	47.0	h12	2.15	
600	80	10/20/40	175	60	95	58	80	22	88	57.0	h12	2.15		
62	100	16	5/10/16	59	10	39	8	20	9	36	9.6	h10	1.10	
	120	20	5/10/20/40	68	12	43	10	25	10	40	11.5	h11	1.10	
	150	20	5/10/20/40	72	15	47	12	25	11	44	14.3	h11	1.10	
	170	25	5/10/25	81	17	51	15	30	12	48	16.2	h11	1.10	
	200	32	5/10/20/32/64	100	20	60	18	40	14	56	19.0	h11	1.30	
	250	32	5/10/20/32/64	114	25	64	22	50	15	60	23.9	h12	1.30	
	300	40	5/10/12/16/20/25/30/40	118	30	68	28	50	16	64	28.6	h12	1.60	
	350	50	5/10/12/16/20/25/30/40	133	35	73	32	60	17	68	33.0	h12	1.60	
	500	63	10/20/40	167	50	87	48	80	20	80	47.0	h12	2.15	
	600	80	10/20/40	175	60	95	58	80	22	88	57.0	h12	2.15	

1) The allocation of screw ends to the bearing assemblies is clearly defined by the version.

**End bearings
for screw ends Form 61, 62**

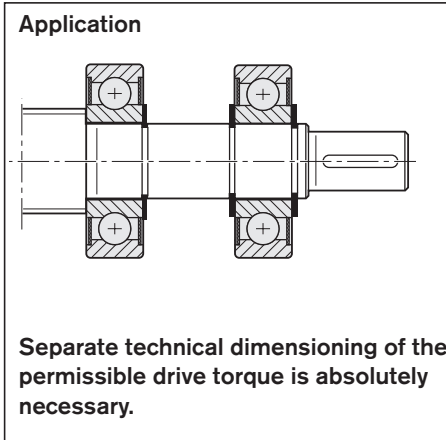

Version ¹⁾	Keyway as per DIN 6885			Centering hole		Hex socket		Thread		Bearing assembly LAD ²⁾ Part number
	b Pg	l	t	Z	t _Z	S	t _S	G	t _G	
050	-	-	-	-	-	-	-	-	-	R1590 605 00
060	-	-	-	-	-	-	-	-	-	R1590 606 00
100	-	-	-	M3	9.0	-	-	M3	5	R1590 610 00
120	-	-	-	M3	9.0	4	4	M4	6	R1590 612 00
150	-	-	-	M4	10.0	4	4	M5	8	R1590 615 00
170	-	-	-	M5	12.5	4	4	M6	9	R1590 617 00
200	-	-	-	M6	16.0	5	5	M6	9	R1590 620 00
250	-	-	-	M8	19.0	6	6	M8	12	R1590 625 00
300	-	-	-	M10	22.0	10	10	M10	15	R1590 630 00
350	-	-	-	M12	28.0	10	10	M12	18	R1590 635 00
500	-	-	-	M16	36.0	17	17	M16	24	R1590 650 00
600	-	-	-	M20	42.0	19	19	M20	42	R1590 660 00
100	2	14	1.2	M3	9.0	-	-	M3	5	R1590 610 00
120	3	20	1.8	M3	9.0	4	4	M4	6	R1590 612 00
150	4	20	2.5	M4	10.0	4	4	M5	8	R1590 615 00
170	5	25	3.0	M5	12.5	4	4	M6	9	R1590 617 00
200	6	28	3.5	M6	16.0	5	5	M6	9	R1590 620 00
250	6	36	3.5	M8	19.0	6	6	M8	12	R1590 625 00
300	8	36	4.0	M10	22.0	10	10	M10	15	R1590 630 00
350	10	40	5.0	M12	28.0	10	10	M12	18	R1590 635 00
500	14	63	5.5	M16	36.0	17	17	M16	24	R1590 650 00
600	16	63	6.0	M20	42.0	19	19	M20	42	R1590 660 00

2) Scope of delivery per assembly: 1 bearing, 2 retaining rings. For application with form 61-62: 2x assemblies required.

Form 71, 72

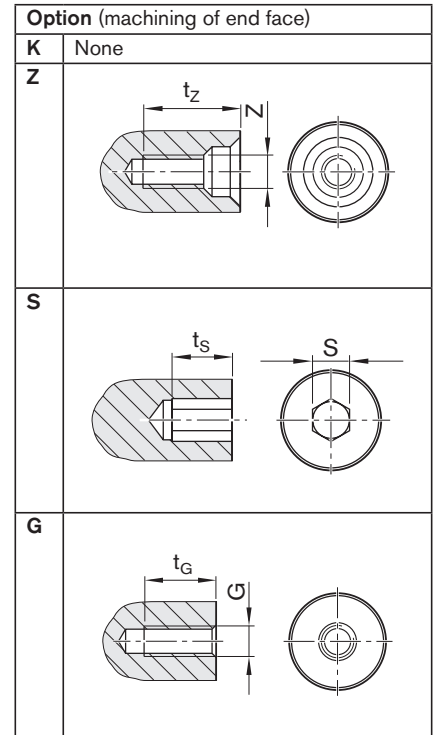
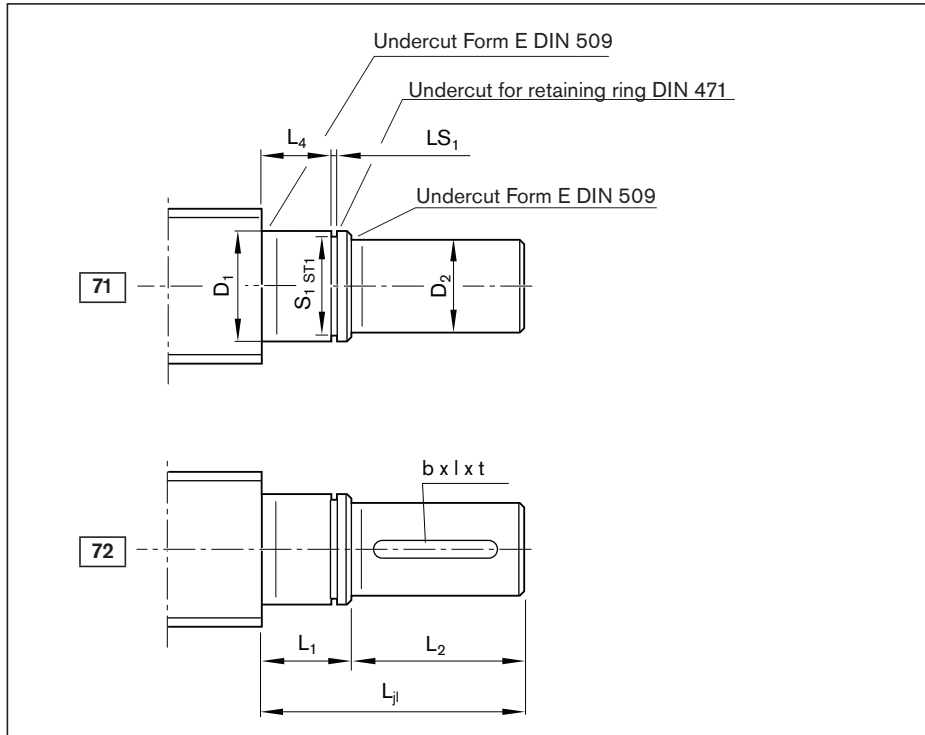

Ordering data:

BASA	20x5R x 3	SEM-E-S - 4	00	1	2	T7	R	72Z120	51Z120	1250	0	1
------	-----------	-------------	----	---	---	----	---	--------	--------	------	---	---

Form	Version ¹⁾	Size		(mm)								
		d ₀	P	L _{j1}	D ₁ j6	L ₁	D ₂ h7	L ₂	L ₄	S ₁	ST1	LS ₁ H13
71	050	8	1/2/2.5/5	19	5	7	4	12	5	4.8	h10	0.70
	060	12	2/5/10	24	6	8	5	16	6	5.7	h10	0.80
	100	16	5/10/16	32	10	12	8	20	9	9.6	h10	1.10
	120	20	5/10/20/40	38	12	13	10	25	10	11.5	h11	1.10
	150	20	5/10/20/40	39	15	14	12	25	11	14.3	h11	1.10
	170	25	5/10/25	45	17	15	15	30	12	16.2	h11	1.10
	200	32	5/10/20/32/64	58	20	18	18	40	14	19.0	h11	1.30
	250	32	5/10/20/32/64	69	25	19	22	50	15	23.9	h12	1.30
	300	40	5/10/12/16/20/25/30/40	70	30	20	28	50	16	28.6	h12	1.60
	350	50	5/10/12/16/20/25/30/40	82	35	22	32	60	17	33.0	h12	1.60
	500	63	10/20/40	107	50	27	48	80	20	47.0	h12	2.15
	600	80	10/20/40	109	60	29	58	80	22	57.0	h12	2.15
72	100	16	5/10/16	32	10	12	8	20	9	9.6	h10	1.10
	120	20	5/10/20/40	38	12	13	10	25	10	11.5	h11	1.10
	150	20	5/10/20/40	39	15	14	12	25	11	14.3	h11	1.10
	170	25	5/10/25	45	17	15	15	30	12	16.2	h11	1.10
	200	32	5/10/20/32/64	58	20	18	18	40	14	19.0	h11	1.30
	250	32	5/10/20/32/64	69	25	19	22	50	15	23.9	h12	1.30
	300	40	5/10/12/16/20/25/30/40	70	30	20	28	50	16	28.6	h12	1.60
	350	50	5/10/12/16/20/25/30/40	82	35	22	32	60	17	33.0	h12	1.60
	500	63	10/20/40	107	50	27	48	80	20	47.0	h12	2.15
600	80	10/20/40	109	60	29	58	80	22	57.0	h12	2.15	

1) The allocation of screw ends to the bearing assemblies is clearly defined by the version.

**End bearings
for screw ends Form 71, 72**

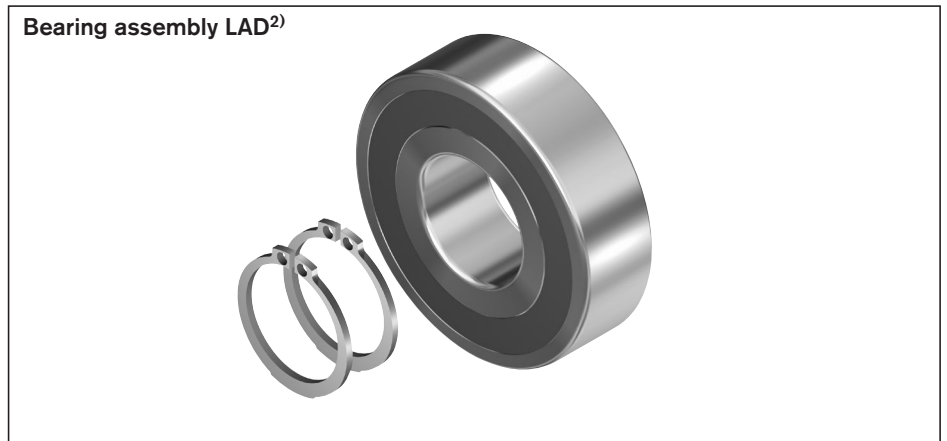
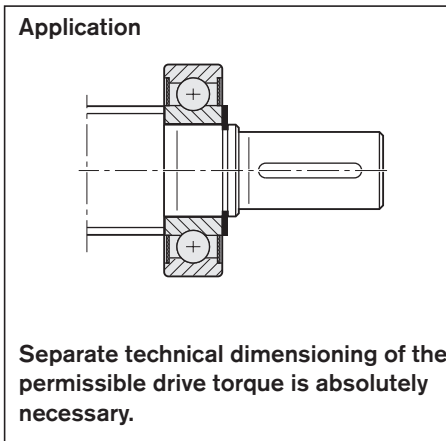

Version ¹⁾	Keyway as per DIN 6885			Centering hole		Hex socket		Thread	t _G	Bearing assembly LAD ²⁾ Part number
	b P9	l	t	Z	t _Z	S	t _S			
050	-	-	-	-	-	-	-	-	-	R1590 605 00
060	-	-	-	-	-	-	-	-	-	R1590 606 00
100	-	-	-	M3	9	-	-	M3	5	R1590 610 00
120	-	-	-	M3	9	4	4	M4	6	R1590 612 00
150	-	-	-	M4	10	4	4	M5	8	R1590 615 00
170	-	-	-	M5	12.5	4	4	M6	9	R1590 617 00
200	-	-	-	M6	16	5	5	M6	9	R1590 620 00
250	-	-	-	M8	19	6	6	M8	12	R1590 625 00
300	-	-	-	M10	22	10	10	M10	15	R1590 630 00
350	-	-	-	M12	28	10	10	M12	18	R1590 635 00
500	-	-	-	M16	36	17	17	M16	24	R1590 650 00
600	-	-	-	M20	42	19	19	M20	30	R1590 660 00
100	2	14	1.2	M3	9	-	-	M3	5	R1590 610 00
120	3	20	1.8	M3	9	4	4	M4	6	R1590 612 00
150	4	20	2.5	M4	10	4	4	M5	8	R1590 615 00
170	5	25	3.0	M5	12.5	4	4	M6	9	R1590 617 00
200	6	28	3.5	M6	16	5	5	M6	9	R1590 620 00
250	6	36	3.5	M8	19	6	6	M8	12	R1590 625 00
300	8	36	4.0	M10	22	10	10	M10	15	R1590 630 00
350	10	40	5.0	M12	28	10	10	M12	18	R1590 635 00
500	14	63	5.5	M16	36	17	17	M16	24	R1590 650 00
600	16	63	6.0	M20	42	19	19	M20	30	R1590 660 00

2) Scope of delivery: 1 bearing, 2 retaining rings.

Form 81, 81A, 82, 82A

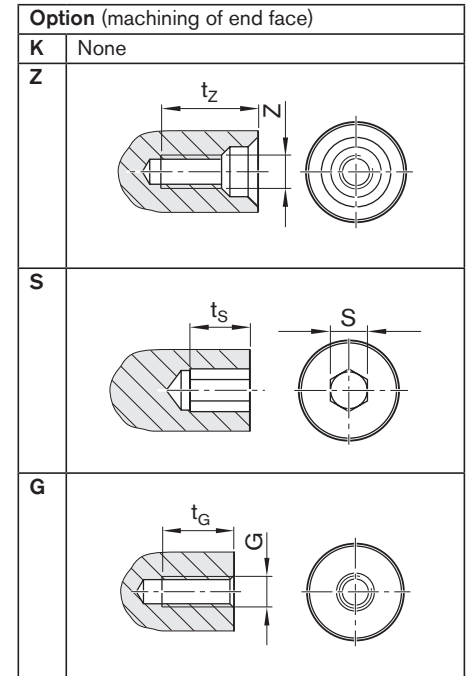
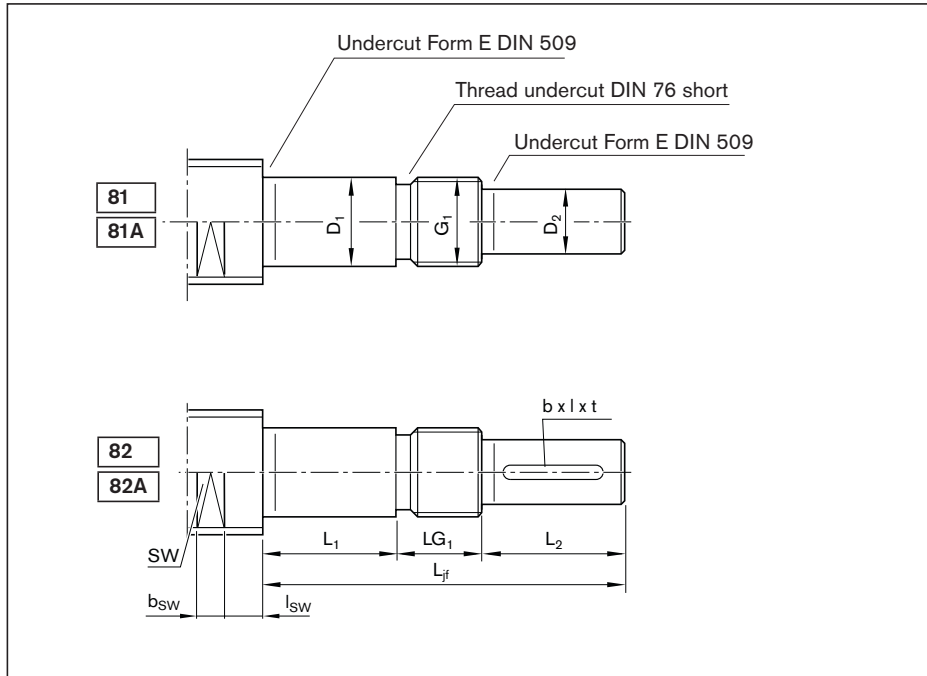

Ordering data:

BASA	20x5R x 3	SEM-E-S - 4	00	1	2	T7	R	81AZ120	41Z120	1250	0	1
------	-----------	-------------	----	---	---	----	---	---------	--------	------	---	---

Form	Version ¹⁾	Size		(mm)										Centering hole		Hex socket		Thread	
		d ₀	P	L _{jf}	D ₁ h6	L ₁	D ₂ h7	L ₂	G ₁	LG ₁	Z	t _z	S	t _s	G	t _g			
81/81A	060	12	2/5/10	40	6	14	5	16	M6x0.5	10	-	-	-	-	-	-			
	061	12	2/5/10	41	6	10	5	16	M6x0.5	15	-	-	-	-	-	-			
	100	16	5/10/16	50	10	18	8	20	M10x1	12	M3	9.0	-	-	M3	5			
	104	16	5/10/16	66	10	34	8	20	M10x1	12	M3	9.0	-	-	M3	5			
	120	20	5/10/20/40	60	12	23	10	25	M12x1	12	M3	9.0	4	4	M4	6			
	122	20	5/10/20/40	60	12	17	10	25	M12x1	18	M3	9.0	4	4	M4	6			
	123	20	5/10/20/40	60	12	23	10	25	M12x1	12	M3	9.0	4	4	M4	6			
	124	20	5/10/20/40	75	12	38	10	25	M12x1	12	M3	9.0	4	4	M4	6			
	151	25	5/10/25	60	15	19	12	25	M15x1	16	M4	10.0	4	4	M5	8			
	170	25	5/10/25	75	17	23	15	30	M17x1	22	M5	12.5	4	4	M6	9			
	173 ²⁾	25	5/10/25	75	17	23	15	30	M17x1	22	M5	12.5	4	4	M6	9			
	175	25	5/10/25	78	17	26	15	30	M17x1	22	M5	12.5	4	4	M6	9			
	200	32	5/10/20/32/64	88	20	26	18	40	M20x1	22	M6	16.0	5	5	M6	9			
	203	32	5/10/20/32/64	78	20	26	16	35	M20x1	17	M5	12.5	4	4	M6	9			
	204	32	5/10/20/32/64	80	20	25	18	40	M20x1	15	M6	16.0	5	5	M6	9			
	206	32	5/10/20/32/64	116	20	54	18	40	M20x1	22	M6	16.0	5	5	M6	9			
	250	40	10/12/16/20/25/30/40	130	25	54	22	50	M25x1.5	26	M8	19.0	6	6	M8	12			
	300	40	5/10/12/16/20/25/30/40	101	30	25	25	50	M30x1.5	26	M10	22.0	8	8	M10	15			
	301	40	5/10/12/16/20/25/30/40	93	30	25	25	50	M30x1.5	18	M10	22.0	8	8	M10	15			
	302	40	10/12/16/20/25/30/40	130	30	54	25	50	M30x1.5	26	M10	22.0	8	8	M10	15			
	305	40	10/12/16/20/25/30/40	121	30	53	25	50	M30x1.5	18	M10	22.0	8	8	M10	15			
	306	50	10/12/16/20/25/30/40	130	30	54	25	50	M30x1.5	26	M10	22.0	8	8	M10	15			
	309	40	5/10/12/16/20/40	150	30	74	25	50	M30x1.5	26	M10	22.0	8	8	M10	15			
	350	50	5	110	35	32	30	50	M35x1.5	28	M10	22.0	10	10	M12	18			
	351	50	5/10/12/16/20/25	158	35	82	30	50	M35x1.5	26	M10	22.0	10	10	M12	18			
	400	63	10/20/40	132	40	44	36	60	M40x1.5	28	M12	28.0	12	12	M12	18			
	401	63	10/20/40	178	40	90	36	60	M40x1.5	28	M12	28.0	12	12	M12	18			
	500	80	10/20/40	154	50	52	40	70	M50x1.5	32	M16	36.0	12	12	M16	24			
	501	80	10/20/40	208	50	106	40	70	M50x1.5	32	M16	36.0	12	12	M16	24			
	601	80	10/20/40	234	60	122	55	80	M60x2	32	M20	42.0	19	19	M20	30			

1) The allocation of screw ends to the bearing assemblies is clearly defined by the version.

2) Version 173 only available in Form 81A

End bearings for screw ends Form 81, 81A, 82, 82A

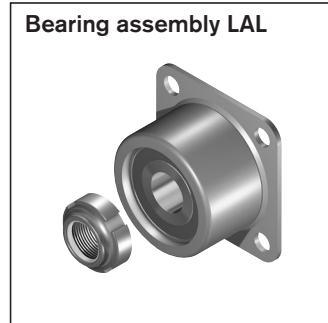
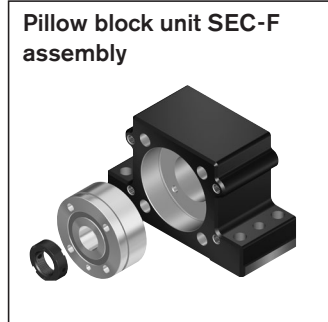
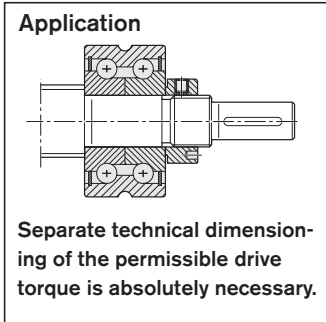

Version ¹⁾	Wrench size		I _{SW}	Pillow block unit for motor attachment			Bearing assembly			
	SW	b _{SW}		SEC-F Part number	SEB-F Part number	SES-F Part number	LAF Part number	LAN Part number	LAL Part number	LAS Part number
060	9	10	8.5	-	R1591 106 20	-	-	R1590 106 00	-	-
061	9	10	8.5	-	-	-	-	-	R1590 406 00	-
100	11	10	8.5	-	R1591 110 20	-	-	R1590 110 00	-	-
104	11	10	8.5	-	-	-	-	-	-	R159A 410 01
120	15	10	42.0	R1594 012 00	R1591 112 20	R1595 012 20	R1590 012 00	R1590 112 00	-	-
122	15	10	8.5	-	-	-	-	-	R1590 412 00	-
123	15	10	8.5	-	R1591 112 20	-	R1590 012 00	R1590 112 00	-	-
124	15	10	8.5	-	-	-	-	-	-	R159A 412 01
151	19	10	10.5	-	-	-	-	-	R1590 415 00	-
170	19	10	42.0	-	R1591 117 30	R1595 017 20	R1590 017 30	R1590 117 30	-	-
173 ²⁾	19	10	10.5	-	R1591 117 30	-	R1590 017 30	R1590 117 30	-	-
175	19	10	10.5	-	-	-	-	-	-	R159A 417 01 ³⁾
200	24	15	10.5	-	R1591 120 30	-	R1590 020 30	R1590 120 30	-	-
203	24	15	40.0	R1594 020 00	-	R1595 020 20	R1590 020 00	R1590 120 00	-	-
204	24	15	10.5	-	-	-	-	-	R1590 420 00	-
206	24	15	10.5	-	-	-	-	-	-	R159A 420 01
250	30	15	12.5	-	R1591 225 30	-	R1590 325 30	R1590 225 30	-	-
300	30	15	12.5	-	R1591 130 30	-	R1590 030 30	R1590 130 30	-	-
301	30	15	45.0	R1594 030 00	-	R1595 030 20	-	-	-	-
302	30	15	37.0	-	-	R1595 330 20	-	-	-	-
305	30	15	37.0	-	-	-	-	-	-	-
306	41	22	15.5	-	R1591 230 30	-	R1590 330 30	R1590 230 30	-	-
309	30	15	12.5	-	-	-	-	-	-	R159A 430 01
350	41	22	15.5	-	R1591 135 30	-	R1590 035 30	R1590 135 30	-	-
351	41	22	15.5	-	-	-	-	-	-	R159A 435 01
400	50	27	16.5	-	R1591 140 30	-	R1590 040 30	R1590 140 30	-	-
401	50	27	16.5	-	-	-	-	-	-	R159A 440 01
500	60	27	18.5	-	R1591 150 30	-	R1590 050 30	R1590 150 30	-	-
501	60	27	18.5	-	-	-	-	-	-	R159A 450 01
601	60	27	18.5	-	-	-	-	-	-	R159A 460 01

3) LAS version 1+1 only for size 25 version 175.

Form 81, 81A, 82, 82A

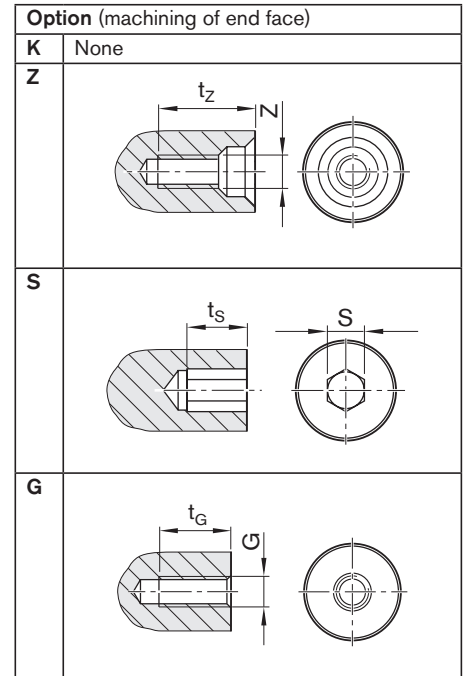
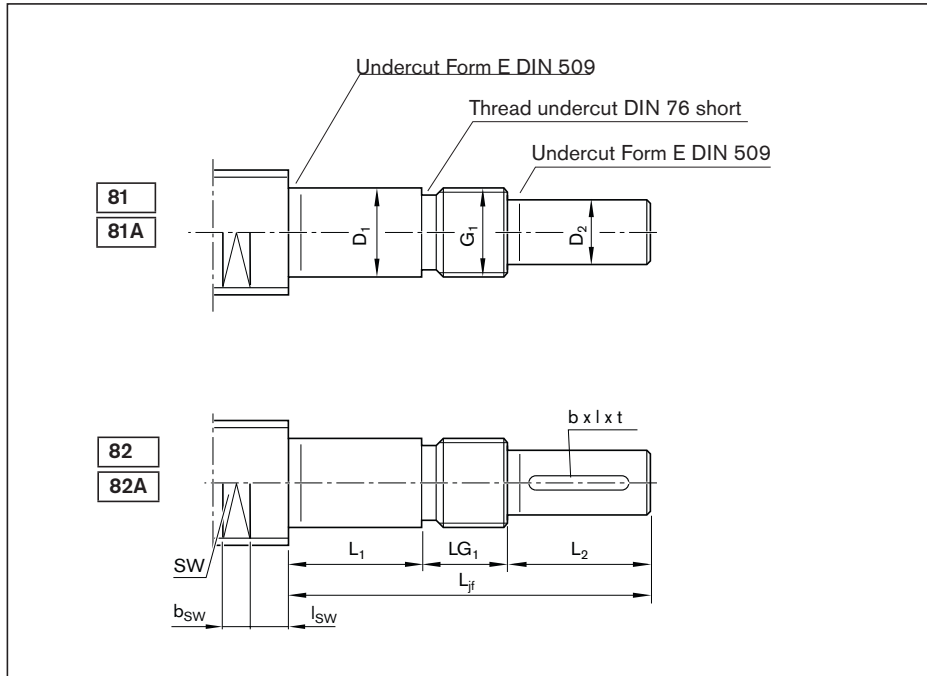

Ordering data:

BASA	20x5R x 3	SEM-E-S - 4	00	1	2	T7	R	82AZ120	41Z120	1250	0	1
------	-----------	-------------	----	---	---	----	---	---------	--------	------	---	---

Form	Version ¹⁾	Size		(mm)										Keyway as per DIN 6885			Centering hole	
		d ₀	P	L _{jf}	D ₁ h6	L ₁	D ₂ h7	L ₂	G ₁	LG ₁	b P9	l	t	Z	t _z			
82/82A	100	16	5/10/16	50	10	18	8	20	M10x1	12	2	14	1.2	M3	9.0			
	104	16	5/10/16	66	10	34	8	20	M10x1	12	2	14	1.2	M3	9.0			
	120	20	5/10/20/40	60	12	23	10	25	M12x1	12	3	20	1.8	M3	9.0			
	123	20	5/10/20/40	60	12	23	10	25	M12x1	12	3	20	1.8	M3	9.0			
	124	20	5/10/20/40	75	12	38	10	25	M12x1	12	3	20	1.8	M3	9.0			
	170	25	5/10/25	75	17	23	15	30	M17x1	22	5	25	3.0	M5	12.5			
	173 ²⁾	25	5/10/25	75	17	23	15	30	M17x1	22	5	25	3.0	M5	12.5			
	175	25	5/10/25	78	17	26	15	30	M17x1	22	5	25	3.0	M5	12.5			
	200	32	5/10/20/32/64	88	20	26	18	40	M20x1	22	6	28	3.5	M6	16.0			
	203	32	5/10/20/32/64	78	20	26	16	35	M20x1	17	5	28	3.0	M5	12.5			
	206	32	5/10/20/32/64	116	20	54	18	40	M20x1	22	6	36	3.5	M6	16.0			
	250	40	10/12/16/20/25/30/40	130	25	54	22	50	M25x1.5	26	6	36	3.5	M8	19.0			
	300	40	5/10/12/16/20/25/30/40	101	30	25	25	50	M30x1.5	26	8	36	4.0	M10	22.0			
	301	40	5/10/12/16/20/25/30/40	93	30	25	25	50	M30x1.5	18	8	36	4.0	M10	22.0			
	302	40	10/12/16/20/25/30/40	130	30	54	25	50	M30x1.5	26	8	36	4.0	M10	22.0			
	305	40	10/12/16/20/25/30/40	121	30	53	25	50	M30x1.5	18	8	36	4.0	M10	22.0			
	306	50	10/12/16/20/25/30/40	130	30	54	25	50	M30x1.5	26	8	36	4.0	M10	22.0			
	309	40	5/10/12/16/20/40	150	30	74	25	50	M30x1.5	26	8	36	4.0	M10	22.0			
	350	50	5	110	35	32	30	50	M35x1.5	28	8	36	4.0	M10	22.0			
	351	50	5/10/12/16/20/25	158	35	82	30	50	M35x1.5	26	8	36	4.0	M10	22.0			
	400	63	10/20/40	132	40	44	36	60	M40x1.5	28	10	40	5.0	M12	28.0			
	401	63	10/20/40	178	40	90	36	60	M40x1.5	28	10	40	5.0	M12	28.0			
	500	80	10/20/40	154	50	52	40	70	M50x1.5	32	12	50	5.0	M16	36.0			
	501	80	10/20/40	208	50	106	40	70	M50x1.5	32	12	50	5.0	M16	36.0			
	601	80	10/20/40	234	60	122	55	80	M60x2	32	16	63	6.0	M20	42.0			

1) The allocation of screw ends to the bearing assemblies is clearly defined by the version.

2) Version 173 only available in Form 81A

3) LAS version 1+1 only for size 25 version 175.

End bearings for screw ends Form 81, 81A, 82, 82A

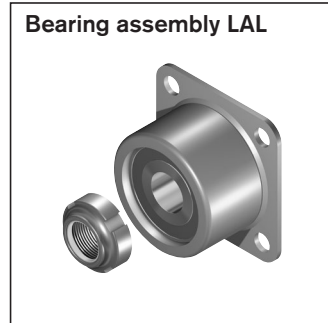
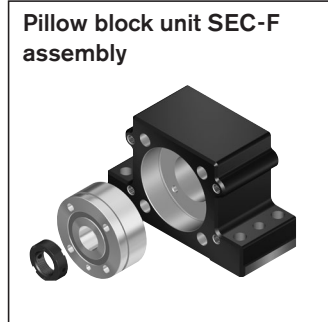
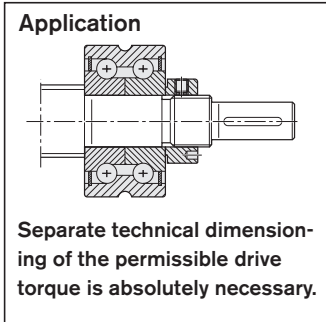

Version ¹⁾	Hex socket		Thread		Wrench size			Pillow block unit for motor attachment			Bearing assembly		
	S	t _S	G	t _G	SW	b _{SW}	l _{SW}	SEC-F Part number	SEB-F Part number	SES-F Part number	LAF Part number	LAN Part number	LAS Part number
100	–	–	M3	5	11	10	8.5	–	R1591 110 20	–	–	R1590110 00	–
104	–	–	M3	5	11	10	8.5	–	–	–	–	–	R159A 410 01
120	4	4	M4	6	15	10	42.0	R1594 012 00	R1591 112 20	R1595 012 20	R1590 012 00	R1590 112 00	–
123	4	4	M4	6	15	10	8.5	–	R1591 112 20	–	R1590 012 00	R1590 112 00	–
124	4	4	M4	6	15	10	8.5	–	–	–	–	–	R159A 412 01
170	4	4	M6	9	19	10	42.0	–	R1591 117 30	R1595 017 20	R1590 017 30	R1590 117 30	–
173 ²⁾	4	4	M6	9	19	10	10.5	–	R1591 117 30	–	R1590 017 30	R1590 117 30	–
175	4	4	M6	9	19	10	10.5	–	–	–	–	–	R159A 417 01 ³⁾
200	5	5	M6	9	24	15	10.5	–	R1591 120 30	–	R1590 020 30	R1590 120 30	–
203	4	4	M6	9	24	15	40.0	R1594 020 00	–	R1595 020 20	R1590 020 00	R1590 120 00	–
206	5	5	M6	9	24	15	10.5	–	–	–	–	–	R159A 420 01
250	6	6	M8	12	30	15	12.5	–	R1591 225 30	–	R1590 325 30	R1590 225 30	–
300	8	8	M10	15	30	15	12.5	–	R1591 130 30	–	R1590 030 30	R1590 130 30	–
301	8	8	M10	15	30	15	45.0	R1594 030 00	–	R1595 030 20	–	–	–
302	8	8	M10	15	30	15	37.0	–	–	R1595 330 20	–	–	–
305	8	8	M10	15	30	15	37.0	–	–	–	–	–	–
306	8	8	M10	15	41	22	15.5	–	R1591 230 30	–	R1590 330 30	R1590 230 30	–
309	8	8	M10	15	30	15	12.5	–	–	–	–	–	R159A 430 01
350	10	10	M12	18	41	22	15.5	–	R1591 135 30	–	R1590 035 30	R1590 135 30	–
351	10	10	M12	18	41	22	15.5	–	–	–	–	–	R159A 435 01
400	12	12	M12	18	50	27	16.5	–	R1591 140 30	–	R1590 040 30	R1590 140 30	–
401	12	12	M12	18	50	27	16.5	–	–	–	–	–	R159A 440 01
500	12	12	M16	24	60	27	18.5	–	R1591 150 30	–	R1590 050 30	R1590 150 30	–
501	12	12	M16	24	60	27	18.5	–	–	–	–	–	R159A 450 01
601	19	19	M20	30	60	27	18.5	–	–	–	–	–	R159A 460 01

Form 831, 83, 83A, 841, 84, 84A

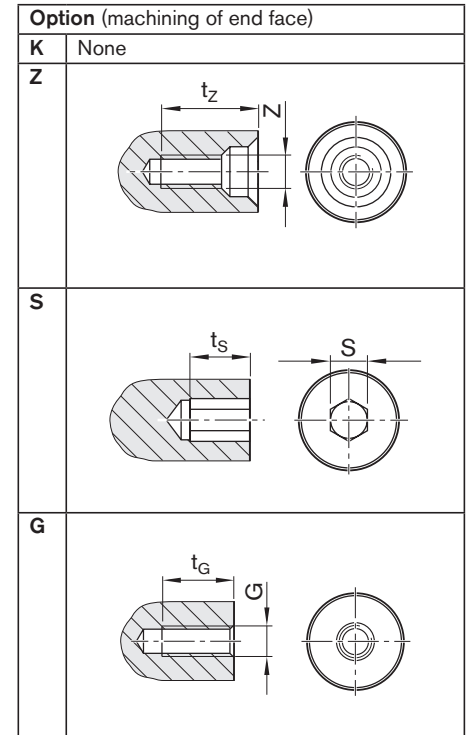
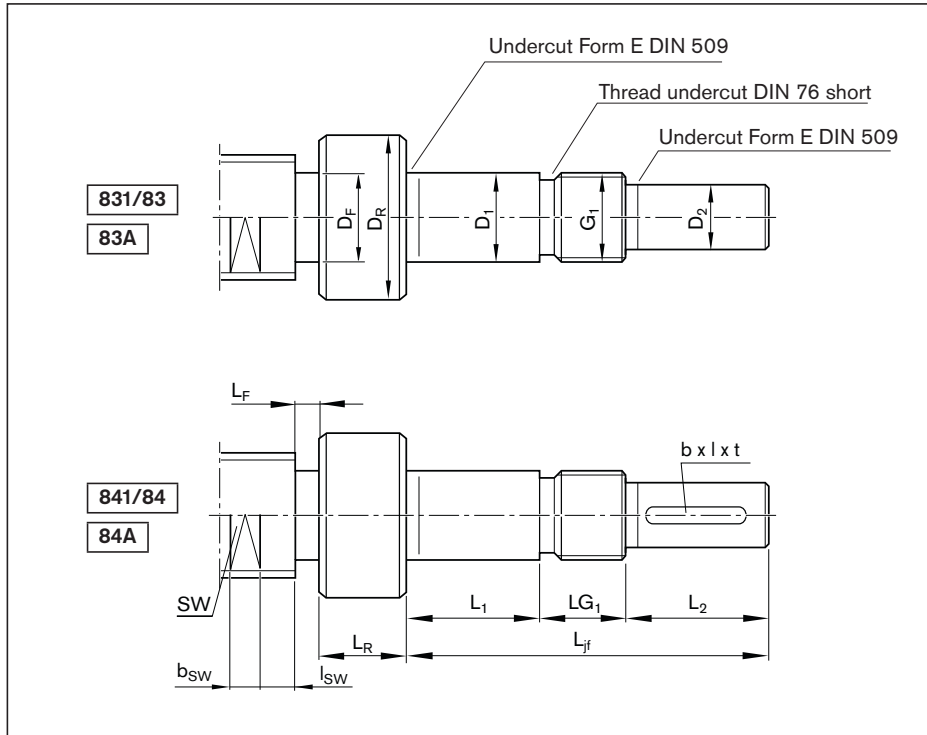

Ordering data:

BASA	20x5R x 3	SEM-E-S - 4	00	1	2	T7	R	83Z200	51Z120	1250	0	1
------	-----------	-------------	----	---	---	----	---	--------	--------	------	---	---

Form	Version ¹⁾	Size		(mm)											Centering hole	
		d ₀	P	L _{jf}	D ₁ h6	L ₁	D ₂ h7	L ₂	G ₁	LG ₁	D _R	L _R	D _F	L _F	Z	t _z
831	060	6	1/2	40	6	14	5	16	M6x0.5	10	12	15	5.0	1	-	-
	061	6	1/2	41	6	10	5	16	M6x0.5	15	12	15	5.0	1	-	-
	062	8	1/2/2.5/5	41	6	10	5	16	M6x0.5	15	12	15	6.0	1	-	-
	065	8	1/2/2.5/5	40	6	14	5	16	M6x0.5	10	12	15	6.0	1	-	-
	120	12	2/5/10	60	12	23	10	25	M12x1	12	16	15	8.0	1	M3	9.0
	121	12	2/5/10	60	12	17	10	25	M12x1	18	15	15	8.0	1	M3	9.0
	122	16	5/10/16	60	12	17	10	25	M12x1	18	18	17	12.0	1	M3	9.0
170	16	5/10/16	75	17	23	15	30	M17x1	22	23	17	12.0	1	M5	12.5	
83/83A	200	20	5/10/20	88	20	26	18	40	M20x1	22	25	15	16.5	8	M6	16.0
	250	25	5/10/25	102	25	26	22	50	M25x1.5	26	32	15	21.0	8	M8	19.0
	300	32	5/10/20/32	101	30	25	25	50	M30x1.5	26	40	20	28.0	8	M10	22.0
	400	40	5/10/12/16/20	132	40	44	36	60	M40x1.5	28	50	20	33.5	8	M12	28.0
	500	50	10/12/20	154	50	52	40	70	M50x1.5	32	60	20	43.5	10	M16	36.0
841	120	12	2/5/10	60	12	23	10	25	M12x1	12	16	15	8.0	1	M3	9.0
	170	16	5/10/16	75	17	23	15	30	M17x1	22	23	17	12.0	1	M5	12.5
84/84A	200	20	5/10/20	88	20	26	18	40	M20x1	22	25	15	16.5	8	M6	16.0
	250	25	5/10/25	102	25	26	22	50	M25x1.5	26	32	15	21.0	8	M8	19.0
	300	32	5/10/20/32	101	30	25	25	50	M30x1.5	26	40	20	28.0	8	M10	22.0
	400	40	5/10/12/16/20/40	132	40	44	36	60	M40x1.5	28	50	20	33.5	8	M12	28.0
	500	50	10/12/20	154	50	52	40	70	M50x1.5	32	60	20	43.5	10	M16	36.0

1) The allocation of screw ends to the bearing assemblies is clearly defined by the version.

**End bearings
for screw ends Form
831, 83, 83A, 841, 84, 84A**

Application

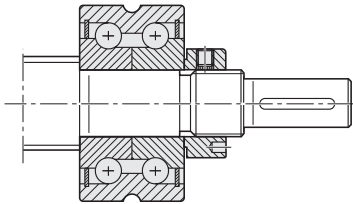

Separate technical dimensioning of the permissible drive torque is absolutely necessary.

Bearing assembly LAF



Shown with slotted nut NMA

Bearing assembly LAN

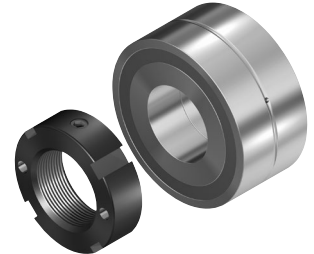

Shown with slotted nut NMZ

Bearing assembly LAL

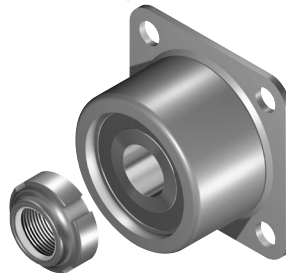

Shown with slotted nut NMG

Pillow block unit SEB-F assembly



Version ¹⁾	Hex socket		Thread		Wrench size			Keyway as per DIN 6885			Bearing assembly			
	S	t _s	G	t _G	SW	b _{sw}	l _{sw}	b P9	l	t	LAF Part number	LAN Part number	LAL Part number	Pillow block unit SEB-F Part number
060	-	-	-	-	-	-	-	-	-	-	-	-	-	R1591 106 00
061	-	-	-	-	-	-	-	-	-	-	-	-	R1590 406 00	-
062	-	-	-	-	-	-	-	-	-	-	-	-	R1590 406 00	-
065	-	-	-	-	-	-	-	-	-	-	-	R1590 106 00	-	R1591 106 00
120	4	4	M4	6	-	-	-	-	-	-	-	R1590 112 00	-	R1591 112 20
121	4	4	M4	6	-	-	-	-	-	-	-	-	R1590 412 00	-
122	4	4	M4	6	-	-	-	-	-	-	-	-	R1590 412 00	-
170	4	4	M6	9	-	-	-	-	-	-	R1590 017 30	R1590 117 30	-	R1591 117 30
200	5	5	M6	9	15	10	8.5	-	-	-	R1590 020 30	R1590 120 30	-	R1591 120 30
250	6	6	M8	12	19	10	10.5	-	-	-	-	-	-	-
300	8	8	M10	15	24	15	10.5	-	-	-	R1590 030 30	R1590 130 30	-	R1591 130 30
400	12	12	M12	18	30	15	12.5	-	-	-	R1590 040 30	R1590 140 30	-	R1591 140 30
500	12	12	M16	24	41	22	15.5	-	-	-	R1590 050 30	R1590 150 30	-	R1591 150 30
120	4	4	M4	6	-	-	-	3	20	1.8	-	R1590 112 00	-	R1591 112 20
170	4	4	M6	9	-	-	-	5	25	3.0	R1590 017 30	R1590 117 30	-	R1591 117 30
200	5	5	M6	9	15	10	8.5	6	28	3.5	R1590 020 30	R1590 120 30	-	R1591 120 30
250	6	6	M8	12	19	10	10.5	6	36	3.5	-	-	-	-
300	8	8	M10	15	24	15	10.5	8	36	4.0	R1590 030 30	R1590 130 30	-	R1591 130 30
400	12	12	M12	18	30	15	12.5	10	40	5.0	R1590 040 30	R1590 140 30	-	R1591 140 30
500	12	12	M16	24	41	22	15.5	12	50	5.0	R1590 050 30	R1590 150 30	-	R1591 150 30

Form 91, 91A, 92, 92A

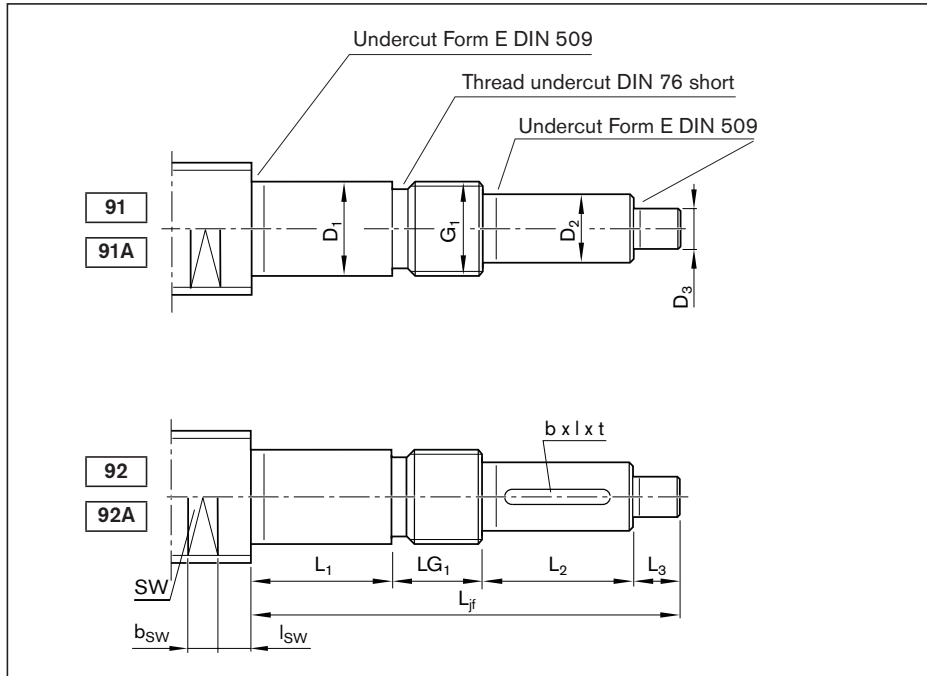

Option (machining of end face)	
K	None

Ordering data:

BASA	20x5R x 3	SEM-E-S - 4	00	1	2	T7	R	92AK120	41Z120	1250	0	1
------	-----------	-------------	----	---	---	----	---	---------	--------	------	---	---

Form	Version ¹⁾	Size		(mm)								
		d ₀	P	L _{jf}	D ₁ h6	L ₁	D ₂ h7	L ₂	D ₃ h7	L ₃	G ₁	LG ₁
91/91A	060	12	2/5/10	50	6	14	5	16	4	10	M6x0.5	10
	100	16	5/10/16	60	10	18	8	20	4	10	M10x1	12
	120	20	5/10/20/40	75	12	23	10	25	6	15	M12x1	12
	170	25	5/10/25	90	17	23	15	30	6	15	M17x1	22
	200	32	5/10/20/32/64	103	20	26	18	40	6	15	M20x1	22
	250	40	10/12/16/20/25/30/40	145	25	54	22	50	6	15	M25x1.5	26
	300	40	5/10/12/16/20/25/30/40	116	30	25	25	50	6	15	M30x1.5	26
	301	50	10/12/16/20/25/30/40	145	30	54	25	50	6	15	M30x1.5	26
	350	50	5	125	35	32	30	50	6	15	M35x1.5	28
	400	63	10/20/40	147	40	44	36	60	6	15	M40x1.5	28
92/92A	500	80	10/20/40	169	50	52	40	70	6	15	M50x1.5	32
	100	16	5/10/16	60	10	18	8	20	4	10	M10x1	12
	120	20	5/10/20/40	75	12	23	10	25	6	15	M12x1	12
	170	25	5/10/25	90	17	23	15	30	6	15	M17x1	22
	200	32	5/10/20/32/64	103	20	26	18	40	6	15	M20x1	22
	250	40	10/12/16/20/25/30/40	145	25	54	22	50	6	15	M25x1.5	26
	300	40	5/10/12/16/20/25/30/40	116	30	25	25	50	6	15	M30x1.5	26
	301	50	10/12/16/20/25/30/40	145	30	54	25	50	6	15	M30x1.5	26
	350	50	5	125	35	32	30	50	6	15	M35x1.5	28
	400	63	10/20/40	147	40	44	36	60	6	15	M40x1.5	28

1) The allocation of screw ends to the bearing assemblies is clearly defined by the version.

**End bearings
for screw ends Form
91, 91A, 92, 92A**

Pillow block unit SEB-F assembly

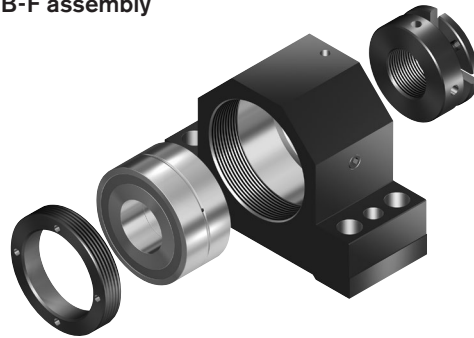

Application

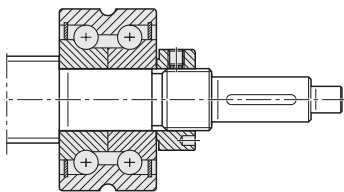

Separate technical dimensioning of the permissible drive torque is absolutely necessary.

Bearing assembly LAF



Shown with slotted nut NMA

Bearing assembly LAN



Shown with slotted nut NMZ

Version ¹⁾	Keyway as per DIN 6885			Wrench size			Module Pillow block unit SEB-F Part number	Bearing LAF Part number	LAN Part number
	b P9	l	t	SW	b _{SW}	l _{SW}			
060	-	-	-	9	10	8.5	R1591 106 20	-	R1590 106 00
100	-	-	-	11	10	8.5	R1591 110 20	-	R1590 110 00
120	-	-	-	15	10	8.5	R1591 112 20	R1590 012 00	R1590 112 00
170	-	-	-	19	10	10.5	R1591 117 30	R1590 017 30	R1590 117 30
200	-	-	-	24	15	10.5	R1591 120 30	R1590 020 30	R1590 120 30
250	-	-	-	30	15	12.5	R1591 225 30	R1590 325 30	R1590 225 30
300	-	-	-	30	15	12.5	R1591 130 30	R1590 030 30	R1590 130 30
301	-	-	-	41	22	15.5	R1591 230 30	R1590 330 30	R1590 230 30
350	-	-	-	41	22	15.5	R1591 135 30	R1590 035 30	R1590 135 30
400	-	-	-	50	27	16.5	R1591 140 30	R1590 040 30	R1590 140 30
500	-	-	-	60	27	18.5	R1591 150 30	R1590 050 30	R1590 150 30
100	2	14	1.2	11	10	8.5	R1591 110 20	-	R1590 110 00
120	3	20	1.8	15	10	8.5	R1591 112 20	R1590 012 00	R1590 112 00
170	5	25	3.0	19	10	10.5	R1591 117 30	R1590 017 30	R1590 117 30
200	6	28	3.5	24	15	10.5	R1591 120 30	R1590 020 30	R1590 120 30
250	6	36	3.5	30	15	12.5	R1591 225 30	R1590 325 30	R1590 225 30
300	8	36	4.0	30	15	12.5	R1591 130 30	R1590 030 30	R1590 130 30
301	8	36	4.0	41	22	15.5	R1591 230 30	R1590 330 30	R1590 230 30
350	8	36	4.0	41	22	15.5	R1591 135 30	R1590 035 30	R1590 135 30
400	10	40	5.0	50	27	16.5	R1591 140 30	R1590 040 30	R1590 140 30
500	12	50	5.0	60	27	18.5	R1591 150 30	R1590 050 30	R1590 150 30

Form 931, 93, 93A, 941, 94, 94A

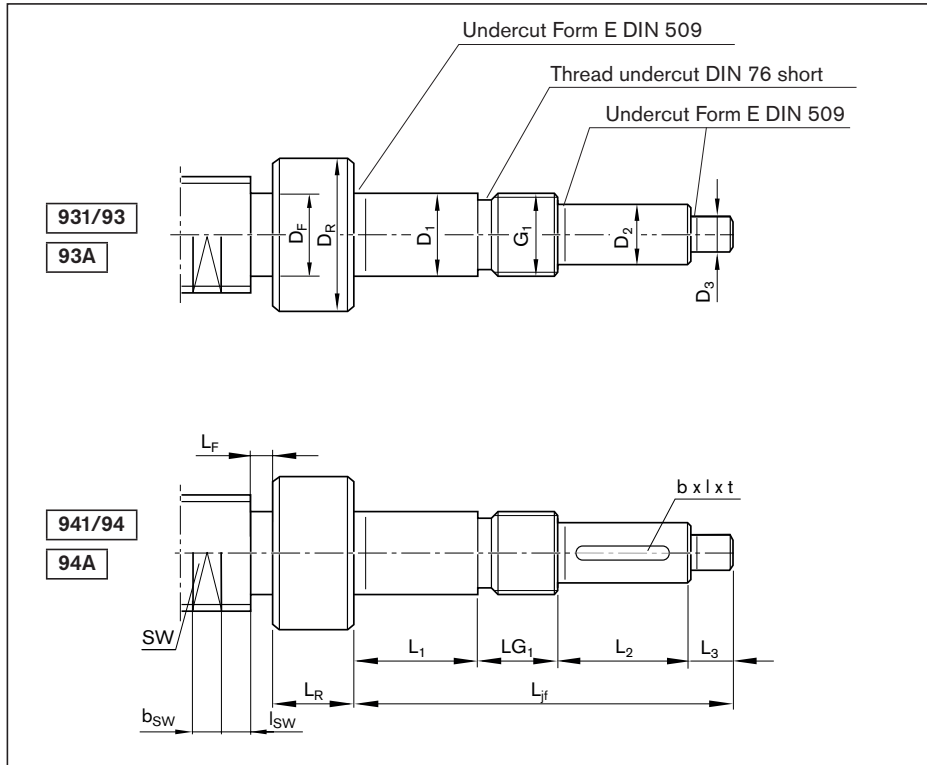

Option (machining of end face)	
K	None

Ordering data:

BASA	20x5R x 3	SEM-E-S - 4	00	1	2	T7	R	93K200	41Z120	1250	0	1
------	-----------	-------------	----	---	---	----	---	--------	--------	------	---	---

Form	Version ¹⁾	Size		(mm)												
		d ₀	P	L _{jf}	D ₁ h6	L ₁	D ₂ h7	L ₂	D ₃ h7	L ₃	G ₁	LG ₁	D _R	L _R	D _F	L _{F max}
931	060	8	1/2/2.5/5	50	6	14	5	16	4	10	M6x0.5	10	12	15	6.0	1
	120	12	2/5/10	75	12	23	10	25	6	15	M12x1	12	16	15	8.0	1
	170	16	5/10/16	90	17	23	15	30	6	15	M17x1	22	23	17	12.0	1
93/93A	200	20	5/10/20	103	20	26	18	40	6	15	M20x1	22	25	15	16.5	8
	250	25	5/10/25	117	25	26	22	50	6	15	M25x1.5	26	32	15	21.0	8
	300	32	5/10/20/32	116	30	25	25	50	6	15	M30x1.5	26	40	20	28.0	8
	400	40	5/10/12/16/20	147	40	44	36	60	6	15	M40x1.5	28	50	20	33.5	8
	500	50	10/12/20	169	50	52	40	70	6	15	M50x1.5	32	60	20	43.5	10
941	120	12	2/5/10	75	12	23	10	25	6	15	M12x1	12	16	15	8.0	1
	170	16	5/10/16	90	17	23	15	30	6	15	M17x1	22	23	17	12.0	1
94/94A	200	20	5/10/20	103	20	26	18	40	6	15	M20x1	22	25	15	16.5	8
	250	25	5/10/25	117	25	26	22	50	6	15	M25x1.5	26	32	15	21.0	8
	300	32	5/10/20/32	116	30	25	25	50	6	15	M30x1.5	26	40	20	28.0	8
	400	40	5/10/12/16/20	147	40	44	36	60	6	15	M40x1.5	28	50	20	33.5	8
	500	50	10/12/20	169	50	52	40	70	6	15	M50x1.5	32	60	20	43.5	10

1) The allocation of screw ends to the bearing assemblies is clearly defined by the version.

**End bearings
for screw ends Form
931, 93, 93A, 941, 94, 94A**

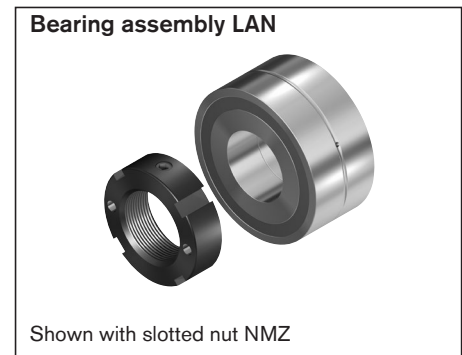
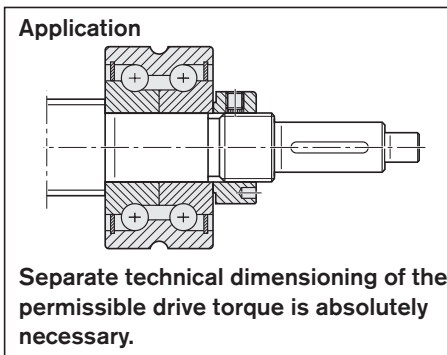
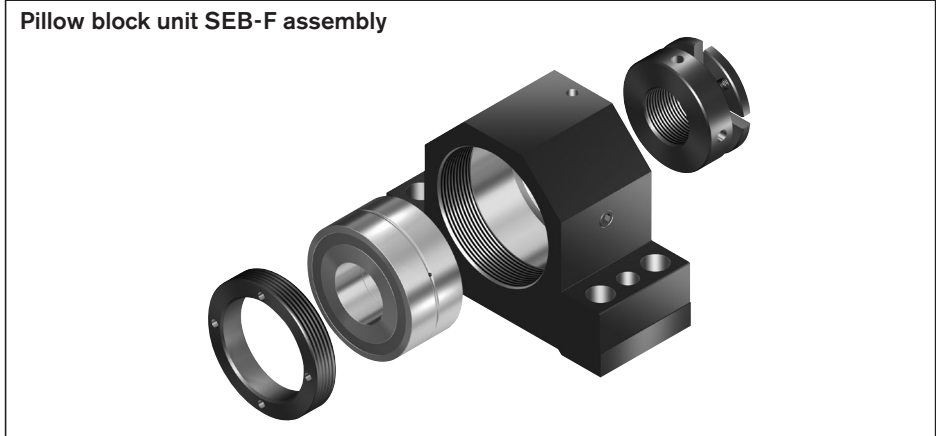

Ball screw assemblies BASA

Version ¹⁾	Keyway as per DIN 6885			Wrench size			Module	Bearing LAF Part number	LAN Part number
	b P9	l	t	SW	b _{SW}	l _{SW}	Pillow block unit SEB-F Part number		
060	-	-	-	-	-	-	R1591 106 00	-	R1591 106 00
120	-	-	-	-	-	-	R1591 112 20	-	R1591 112 00
170	-	-	-	-	-	-	R1591 117 30	R1590 017 30	R1591 117 30
200	-	-	-	15	10	8.5	R1591 120 30	R1590 020 30	R1591 120 30
250	-	-	-	19	10	10.5	-	-	-
300	-	-	-	24	15	10.5	R1591 130 30	R1590 030 30	R1591 130 30
400	-	-	-	30	15	12.5	R1591 140 30	R1590 040 30	R1591 140 30
500	-	-	-	41	22	15.5	R1591 150 30	R1590 050 30	R1591 150 30
120	3	20	1.8	-	-	-	R1591 112 20	-	R1591 112 00
170	5	25	3.0	-	-	-	R1591 117 30	R1590 017 30	R1591 117 30
200	6	28	3.5	15	10	8.5	R1591 120 30	R1590 020 30	R1591 120 30
250	6	36	3.5	19	10	10.5	-	-	-
300	8	36	4.0	24	15	10.5	R1591 130 30	R1590 030 30	R1591 130 30
400	10	40	5.0	30	15	12.5	R1591 140 30	R1590 040 30	R1591 140 30
500	12	50	5.0	41	22	15.5	R1591 150 30	R1590 050 30	R1591 150 30

Form N1, N1A, N2, N2A

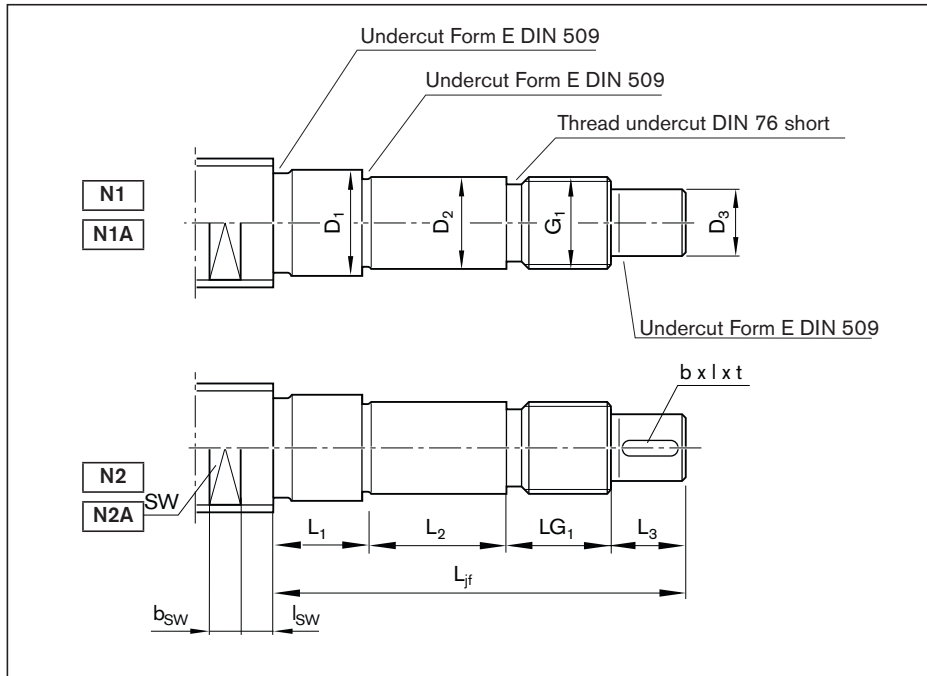

Option (machining of end face)	
K	None
Z	
S	
G	

Ordering data:

BASA	25x5R x 3	SEM-E-S - 4	00	1	2	T7	R	A1K170	41Z170	1250	0	1
------	-----------	-------------	----	---	---	----	---	--------	--------	------	---	---

Form	Version ¹⁾	Size		(mm)								
		d ₀	P	L _{jf}	D ₁ h11	L ₁	D ₂ h6	L ₂	D ₃ h7	L ₃	G ₁	LG ₁
N1/N1A	170	25	5/10/25	85	21.0	10	17	23	15	30	M17x1	22
	200	32	5/10/20/32	98	27.5	10	20	26	18	40	M20x1	22
	250	40	10/12/16/20/25/30/40	140	33.5	10	25	54	22	50	M25x1.5	26
	300	40	5	111	36.0	10	30	25	25	50	M30x1.5	26
	301	50	10/12/16/20/25/30/40	103	43.0	10	30	25	25	50	M30x1.5	18
	350	50	5	120	46.0	10	35	32	30	50	M35x1.5	28
	400	63	10/20/40	142	56.0	10	40	44	36	60	M40x1.5	28
	500	80	10/20/40	164	66.5	10	50	52	40	70	M50x1.5	32
N2/N2A	170	25	5/10/25	85	21.0	10	17	23	15	30	M17x1	22
	200	32	5/10/20/32	98	27.5	10	20	26	18	40	M20x1	22
	250	40	10/12/16/20/25/30/40	140	33.5	10	25	54	22	50	M25x1.5	26
	300	40	5	111	36.0	10	30	25	25	50	M30x1.5	26
	301	50	10/12/16/20/25/30/40	103	43.0	10	30	25	25	50	M30x1.5	18
	350	50	5	120	46.0	10	35	32	30	50	M35x1.5	28
	400	63	10/20/40	142	56.0	10	40	44	36	60	M40x1.5	28
	500	80	10/20/40	164	66.5	10	50	52	40	70	M50x1.5	32

1) The allocation of screw ends to the bearing assemblies is clearly defined by the version.

Separate technical dimensioning of the permissible drive torque is absolutely necessary.

Version ¹⁾	Keyway			Centering hole		Hex socket		Thread		Wrench size		
	b P9	l	t	Z	t _z	S	t _s	G	t _g	SW	b _{sw}	l _{sw}
170	-	-	-	M5	12.5	4	4	M6	9	19	10	10.5
200	-	-	-	M6	16.0	5	5	M6	9	24	15	10.5
250	-	-	-	M8	19.0	6	6	M8	12	30	15	12.5
300	-	-	-	M10	22.0	8	8	M10	15	30	15	12.5
301	-	-	-	M10	22.0	8	8	M10	15	41	22	15.5
350	-	-	-	M10	22.0	10	10	M12	18	41	22	15.5
400	-	-	-	M12	28.0	12	12	M12	18	50	27	16.5
500	-	-	-	M16	36.0	12	12	M16	24	60	27	18.5
170	5	25	3.0	M5	12.5	4	4	M6	9	19	10	10.5
200	6	28	3.5	M6	16.0	5	5	M6	9	24	15	10.5
250	6	36	3.5	M8	19.0	6	6	M8	12	30	15	12.5
300	8	36	4.0	M10	22.0	8	8	M10	15	30	15	12.5
301	8	36	4.0	M10	22.0	8	8	M10	15	41	22	15.5
350	8	36	4.0	M10	22.0	10	10	M12	18	41	22	15.5
400	10	40	5.0	M12	28.0	12	12	M12	18	50	27	16.5
500	12	50	5.0	M16	36.0	12	12	M16	24	60	27	18.5

Overview

Rexroth offers an extensive range of accessories for ball screw assemblies.

These include nut housings, pillow block units, bearings, slotted nuts, and front lube units.

A reasonable ratio of the load capacities of the bearing and the ball screw drive should be taken into account when dimensioning. Further information is provided in this section.

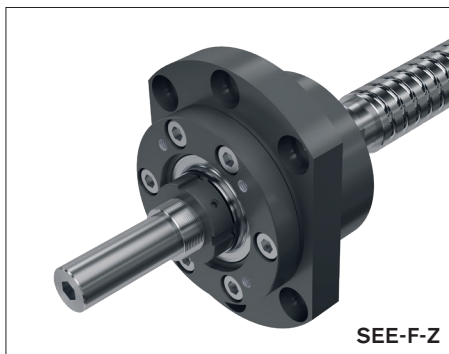
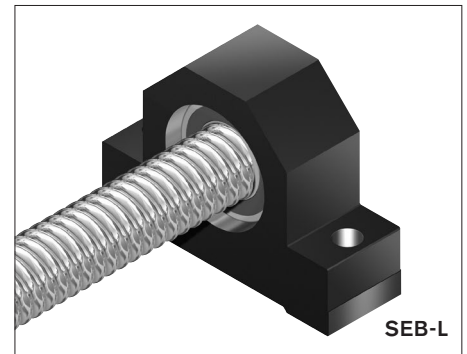
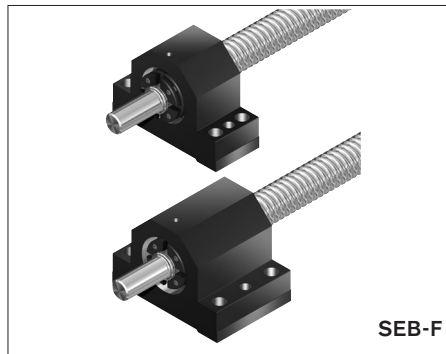
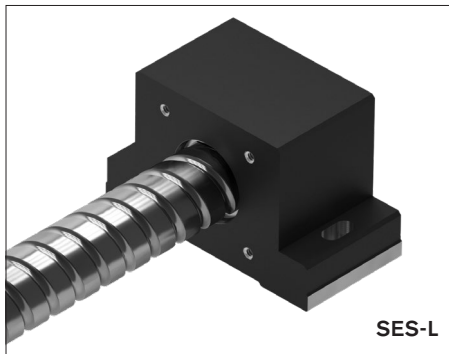
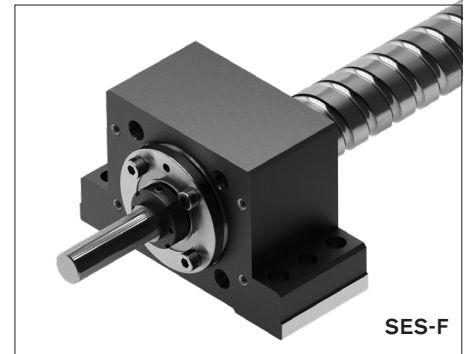
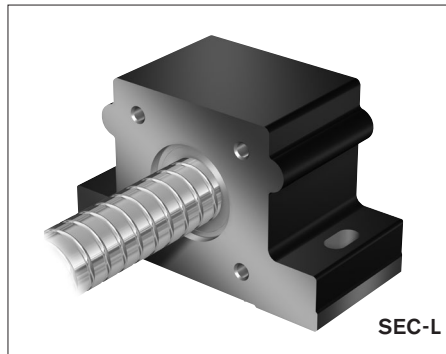
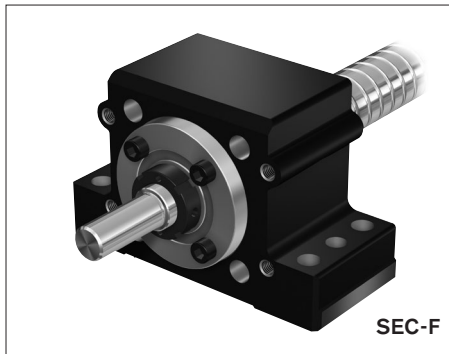
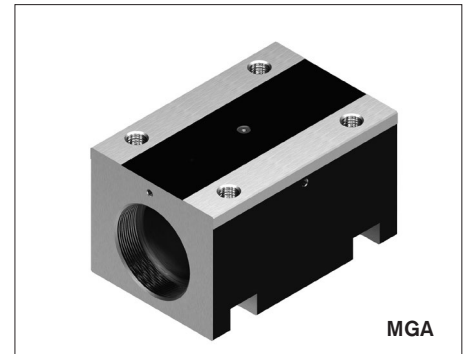
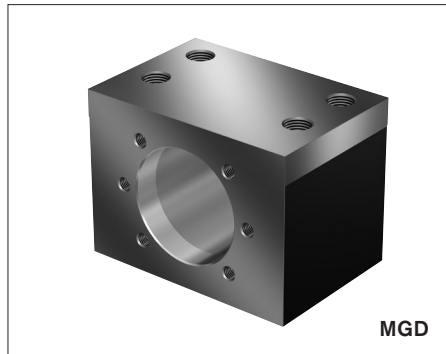
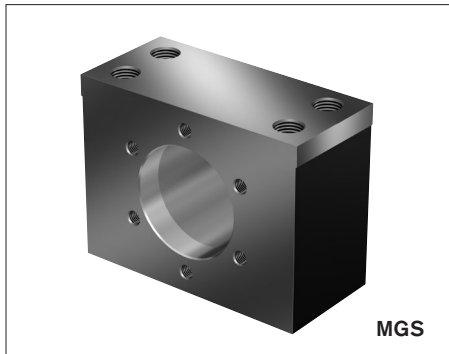

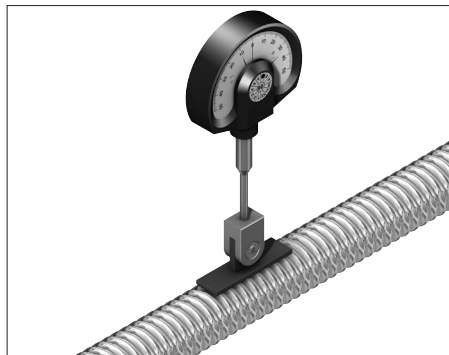
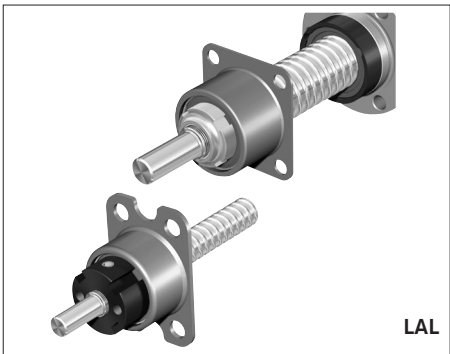
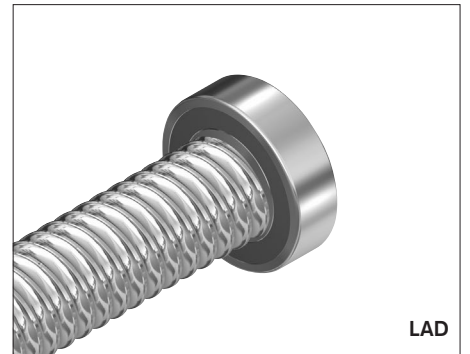
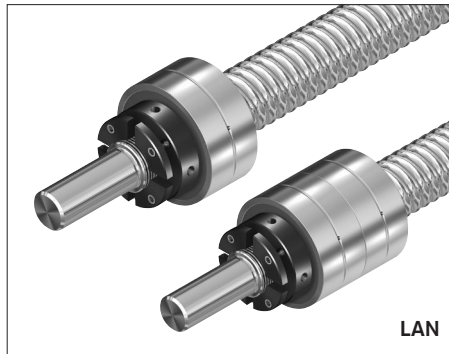
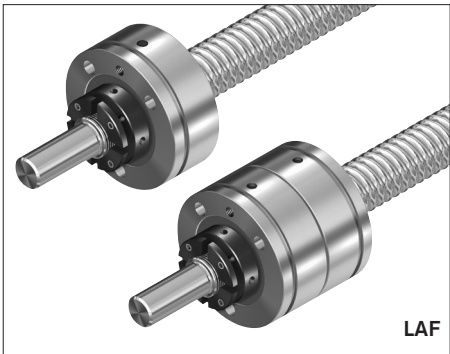

Nut housing MGS

Steel nut housings MGS are designed for FEM-E-S, FDM-E-S, FEP-E-S and SEM-E-S nuts

In addition to bolting, the housings should be locked in place by positive means (e.g. two pins with a diameter equal to that of the screws S_2).

We recommend using screws with a strength class of 8.8.

Tightening torque

see "Installation in the machine" on page 147

Reference edges are formed on both sides.

⚠ If a ball screw assembly with a front lube unit is used, the front lube unit may project beyond the housing. This must be considered when calculating the stroke.

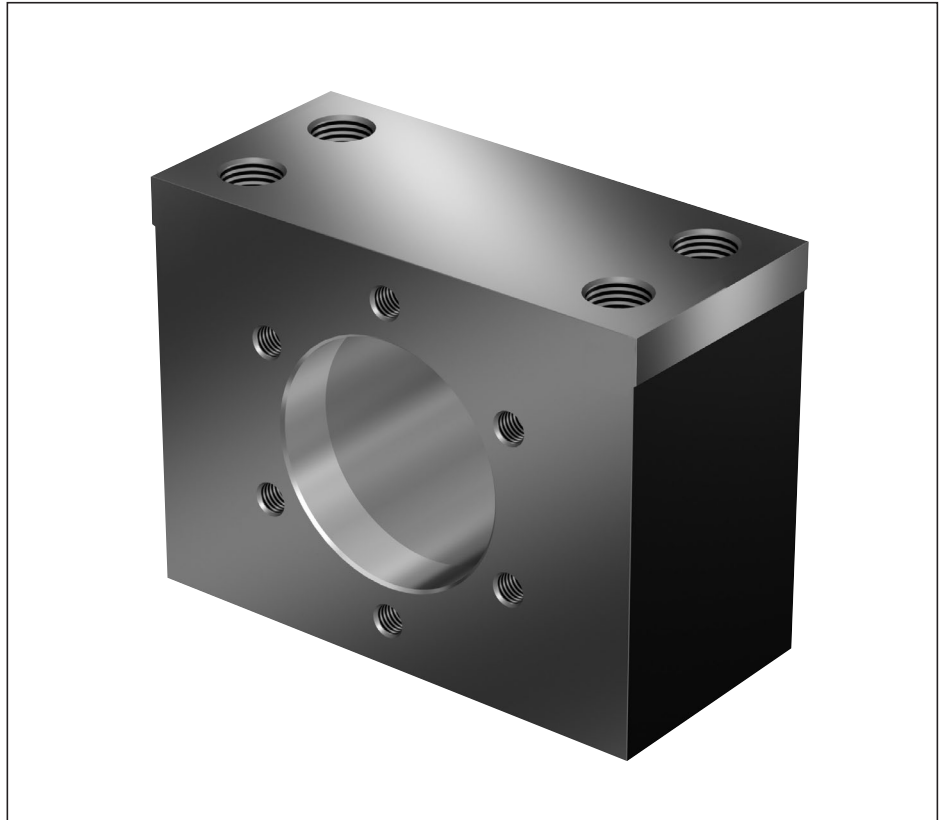

Size $d_0 \times P \times D_w$	Part number	Mass (kg)	Hole pattern FEM-E-B / FEM-E-S / FEP-E-S	SEM-E-S	Hex socket cap screw ISO 4762
16x5R/L x 3	R1506 000 20	0.850	BB3	BB7	M8
16x10R x 3					
16x16R x 3	R1506 100 20	1.050	BB4	BB7	M8
20x5R/L x 3					
20x10R x 3					
20x20R x 3.5					
20x40R x 3.5	R1506 200 20	1.178	BB4	BB7	M8
25x5R/L x 3					
25x10R x 3					
25x25R x 3.5					
32x5R/L x 3.5	R1506 300 20	1.746	BB4	BB7	M10
32x10R x 3.969					
32x20R x 3.969					
32x32R x 3.969					
32x64R x 3.969	R1506 400 20	2.367	BB4	BB7	M12
40x5R/L x 3.5					
40x10R/L x 6					
40x20R x 6					
40x40R x 6	R1506 500 21	6.187	BB4	BB7	M16
50x5R x 3.5	R1506 500 20	4.000	BB4	BB7	M14
50x10R x 6	R1506 500 21	6.187	BB4	BB7	M16
50x16R x 6	R1506 600 20	7.173	BB4	BB7	M16
50x20R x 6.5					
50x40R x 6.5					
63x10R x 6					
80x10R x 6.5	R1506 700 20	9.334	BB4	BB7	M16

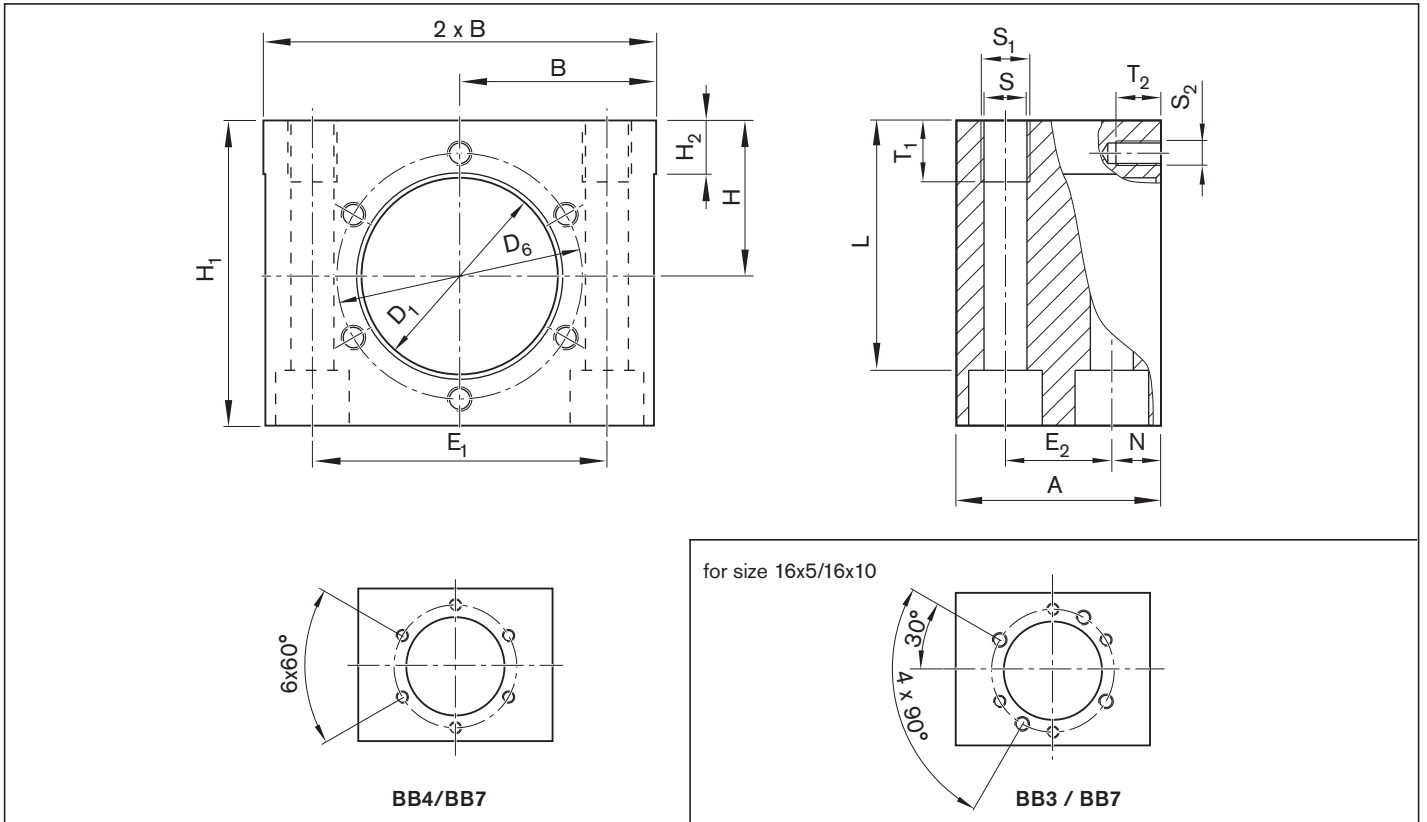

Size $d_0 \times P \times D_w$	(mm)															
	D_1 H7	D_6	A	B ± 0.01	H ± 0.01	H_1	H_2	E_1	E_2	N	S	S_1	T_1	S_2	T_2	Clamping length L
16x5R/L x 3	28	40	40	35.0	28	55	10	52 ± 0.1	20 ± 0.1	10	8.4	M10	15	M6	10	44.0
16x10R x 3																
16x16R x 3	33	45	40	37.5	32	62	10	56 ± 0.1	20 ± 0.1	10	8.4	M10	15	M6	10	51.0
20x5R/L x 3																
20x10R x 3																
20x20R x 3.5	38	50	40	42.5	34	65	10	63 ± 0.1	20 ± 0.1	10	8.4	M10	15	M6	10	54.0
20x40R x 3.5																
25x5R/L x 3																
25x10R x 3																
25x25R x 3.5	48	60	50	47.5	38	75	10	72 ± 0.1	26 ± 0.1	12	10.5	M12	15	M6	10	61.0
32x5R/L x 3.5																
32x10R x 3.969																
32x20R x 3.969	56	68	60	52.5	42	82	12	82 ± 0.1	30 ± 0.1	15	13.0	M16	20	M6	12	64.0
32x32R x 3.969																
32x64R x 3.969																
40x5R/L x 6																
40x10R/L x 6	63	78	65	60.0	50	98	12	93 ± 0.1	35 ± 0.1	15	15.0	M18	25	M8	14	79.5
40x20R x 6																
40x40R x 6	72	90	80	70.0	58	113	12	108 ± 0.15	46 ± 0.15	17	17.0	M20	30	M10	18	92.0
50x5R x 3.5	68	82	65	65.0	52	101	12	100 ± 0.15	35 ± 0.15	15	15.0	M18	30	M8	14	82.5
50x10R x 6	72	90	80	70.0	58	113	12	108 ± 0.15	46 ± 0.15	17	17.0	M20	30	M10	18	92.0
50x16R x 6																
50x20R x 6.5	85	105	80	75.0	65	128	15	121 ± 0.15	46 ± 0.15	17	17.0	M20	30	M10	18	107.0
50x40R x 6.5																
63x10R x 6																
80x10R x 6.5	105	125	80	85.0	78	153	15	140 ± 0.20	46 ± 0.15	17	17.0	M20	30	M12	20	132.0

Nut housing MGD

Steel nut housings MGD are designed for FEM-E-B, FDM-E-B, SEM-E-C and FED-E-B nuts

In addition to bolting, the housings should be locked in place by positive means (for example, two pins with a diameter equal to that of the screws).

We recommend using screws with a strength class of 8.8.

Tightening torque

see "Installation in the machine" on page 147

Reference edges are formed on both sides.

⚠ If a ball screw assembly with a front lube unit is used, the front lube unit may project beyond the housing. This must be considered when calculating the stroke.

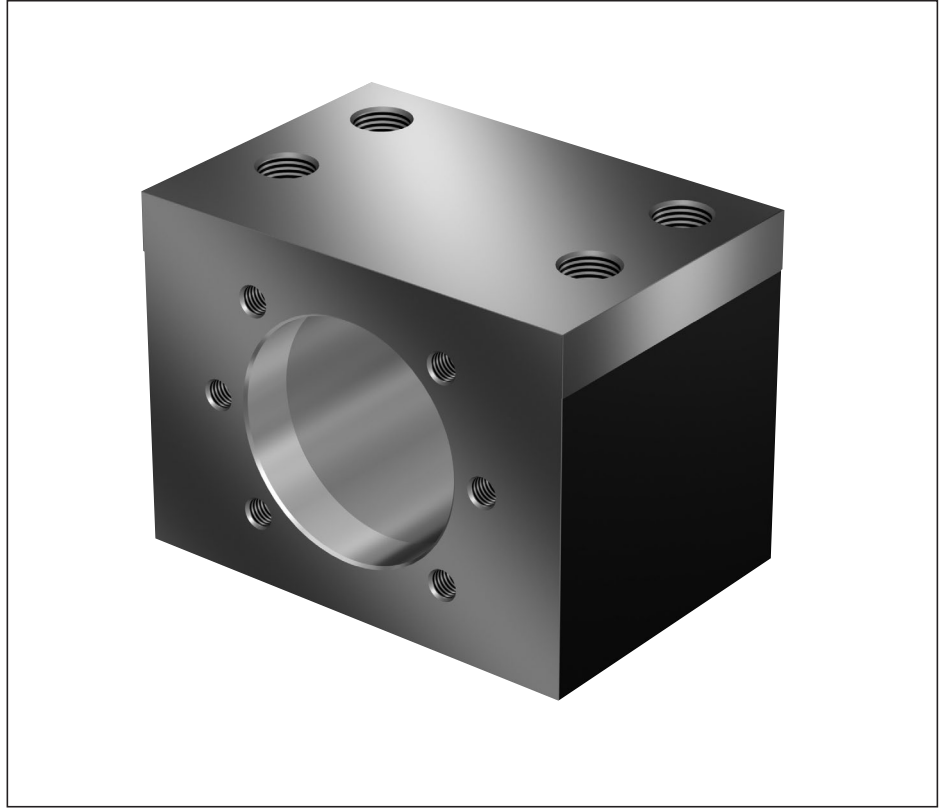

Size	Part number	Mass	Hole pattern	Hex socket cap screw ISO 4762
$d_0 \times P \times D_w$		(kg)		
16 x 5R/L x 3	R1506 000 50	0.91	BB2	M8
16 x 10R x 3				
16 x 16R x 3				
20 x 5R/L x 3	R1506 100 50	1.18	BB2	M8
20 x 10R x 3				
20 x 20R x 3.5				
25 x 5R/L x 3	R1506 200 50	1.33	BB2	M8
25 x 10R x 3				
25 x 25R x 3.5				
32 x 5R/L x 3.5	R1506 300 50	2.27	BB2	M12
32 x 10R x 3.969				
32 x 20R x 3.969				
32 x 32R x 3.969				
40 x 5R/L x 3.5	R1506 400 50	3.61	BB1	M14
40 x 10R/L x 6				
40 x 12R x 6				
40 x 16R x 6				
40 x 20R x 6				
40 x 25R x 6				
40 x 30R x 6				
40 x 40R x 6				
50 x 5R x 3.5	R1506 500 50	5.63	BB1	M16
50 x 10R x 6				
50 x 12R x 6				
50 x 16R x 6				
50 x 20R x 6.5				
50 x 25R x 6.5				
50 x 30R x 6.5				
50 x 40R x 6.5				
63 x 10R x 6	R1506 600 50	6.72	BB1	M16
63 x 20R x 6.5	R1506 600 51	7.67	BB1	M16
63 x 40R x 6.5				
80 x 10R x 6.5	R1506 700 50	8.60	BB1	M16
80 x 20R x 12.7	R1506 700 51	10.53	BB1	M16
80 x 40R x 12.7				

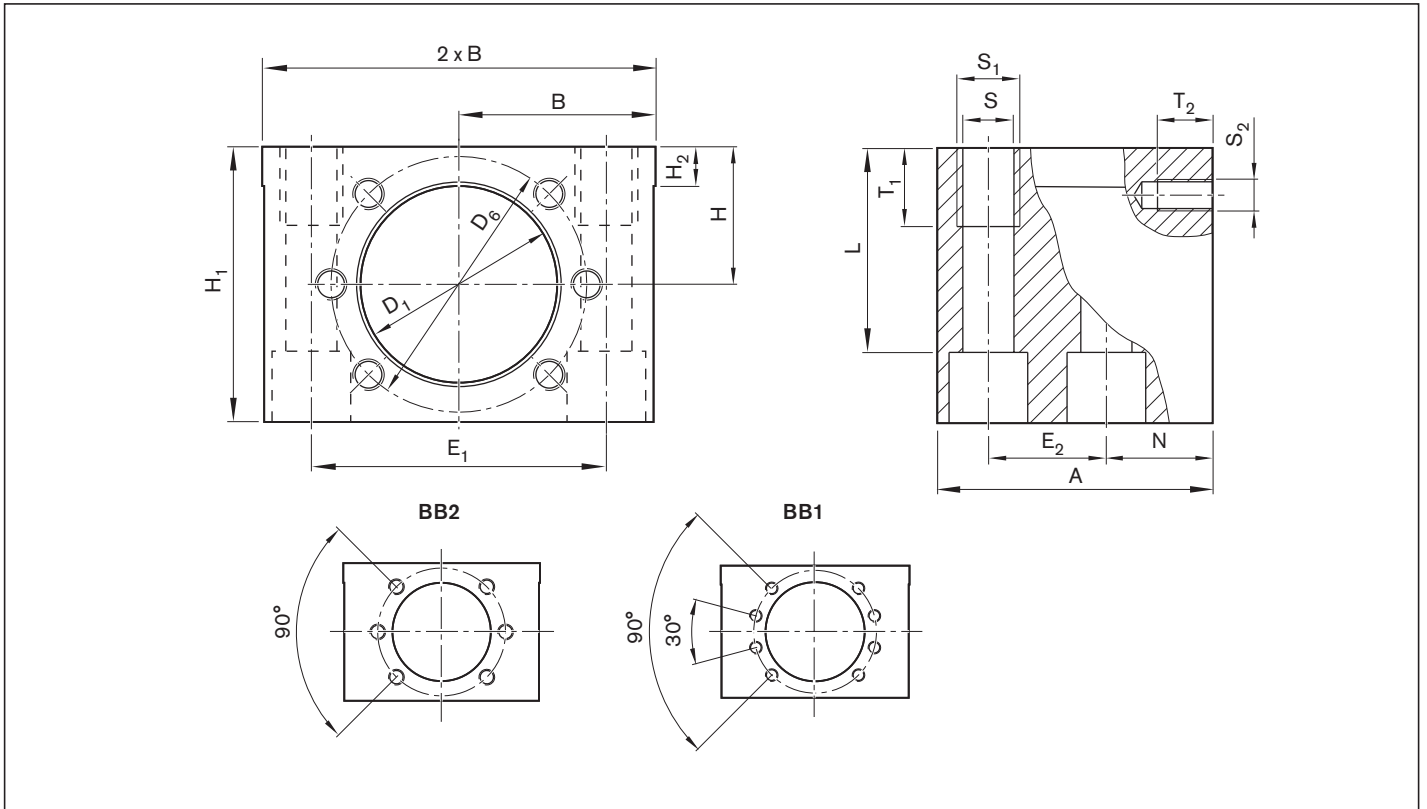

Size	(mm)															
	D ₁	D ₆	A	B	H	H ₁	H ₂	E ₁	E ₂	N	S	S ₁	T ₁	S ₂	T ₂	Clamping length
d ₀ x P x D _w	H7			±0.01	±0.01											L
16 x 5R/L x 3	28	38	50	35	24	48	10	50 ±0.1	20 ±0.1	20	8.4	M10	15	M5	10	37.0
16 x 10R x 3																
16 x 16R x 3																
20 x 5R/L x 3	36	47	55	37.5	28	56	10	55 ±0.1	23 ±0.1	22	8.4	M10	15	M6	11	45.0
20 x 10R x 3																
20 x 20R x 3.5																
25 x 5R x 3	40	51	55	40	30	60	10	60 ±0.1	23 ±0.1	22	8.4	M10	15	M6	11	49.0
25 x 10R x 3																
25 x 25R x 3.5																
32 x 5R/L x 3.5	50	65	70	50	35	70	10	75 ±0.1	30 ±0.1	27	13.0	M16	20	M8	14	52.0
32 x 10R x 3.969																
32 x 20R x 3.969																
32 x 32R x 3.969																
40 x 5R/L x 3.5	63	78	80	60	42	84	12	90 ±0.1	35 ±0.1	31	15.0	M18	25	M8	17	65.5
40 x 10R/L x 6																
40 x 12R x 6																
40 x 16R x 6																
40 x 20R x 6																
40 x 25R x 6																
40 x 30R x 6																
40 x 40R x 6																
50 x 5R x 3.5	75	93	95	70	48	96	12	110 ±0.15	45 ±0.15	34	17.0	M20	30	M10	17	75.0
50 x 10R x 6																
50 x 12R x 6																
50 x 16R x 6																
50 x 20R x 6.5																
50 x 25R x 6.5																
50 x 30R x 6.5																
50 x 40R x 6.5																
63 x 10R x 6	90	108	100	75	55	110	15	120 ±0.2	46 ±0.15	37	17.0	M20	30	M10	20	89.0
63 x 20R x 6.5	95	115	100	80	58	116	15	130 ±0.2	46 ±0.15	37	17.0	M20	30	M12	20	95.0
63 x 40R x 6.5																
80 x 10R x 6.5	105	125	100	85	63	126	15	140 ±0.2	46 ±0.15	37	17.0	M20	30	M12	20	105.0
80 x 20R x 12.7	125	145	100	95	73	146	15	160 ±0.2	46 ±0.15	37	17.0	M20	30	M12	22	125.0
80 x 40R x 12.7																

Nut housing MGA

Aluminum nut housings MGA are designed for ZEM-E-S, ZEM-E-K and ZEM-E-A nuts

We recommend using screws with a strength class of 8.8.

Tightening torque

see "Installation in the machine" on page 147

Reference edges are formed on both sides.

Scope of delivery: Includes set screws, spacer ring, ring nut, washer key

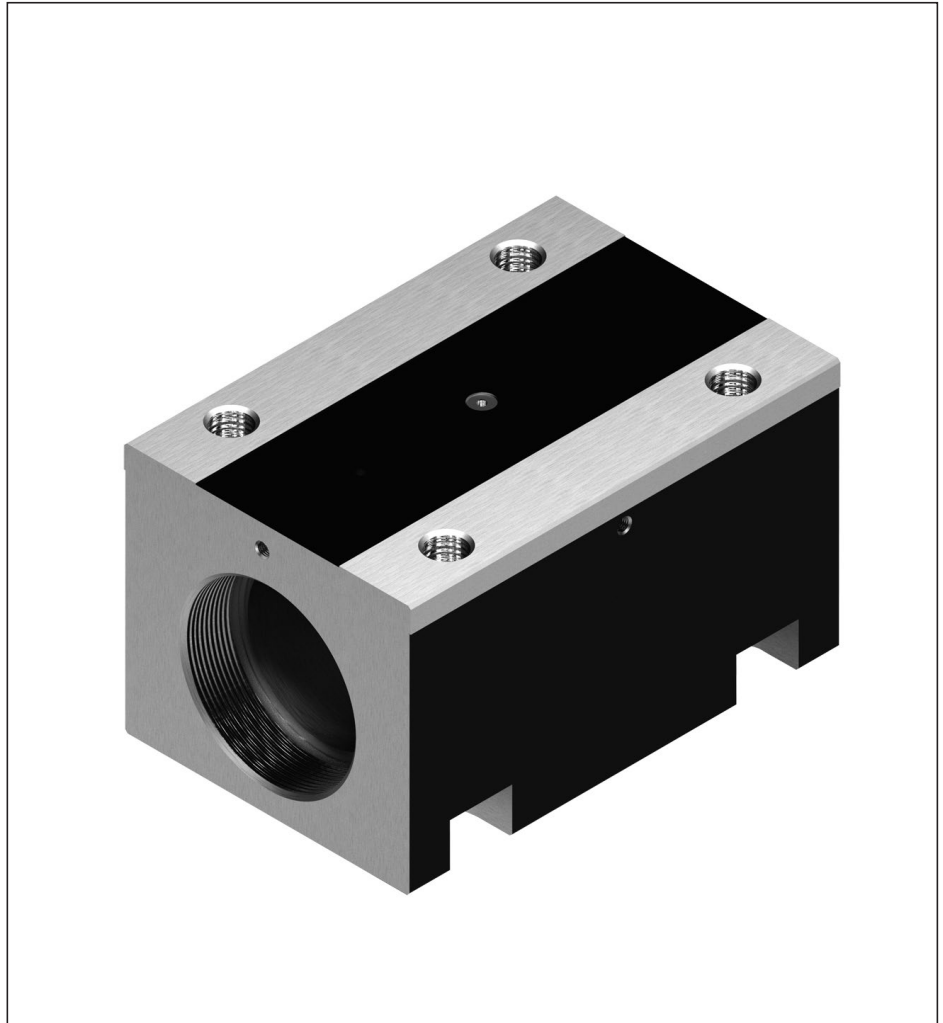

Size		Mass	Hex socket cap screw for screwing from below ISO 4762
$d_0 \times P \times D_W$	Part number	(kg)	
20 x 5R x 3	R1506 100 70	1.10	M8
20 x 10R x 3			
20 x 20R x 3.5			
32 x 5R x 3.5	R1506 300 70	2.31	M10
32 x 10R x 3.969			
32 x 20R x 3.969			
32 x 32R x 3.969			
40 x 5R x 3.5	R1506 400 70	4.32	M14
40 x 10R x 6			
40 x 20R x 6			
40 x 40R x 6			

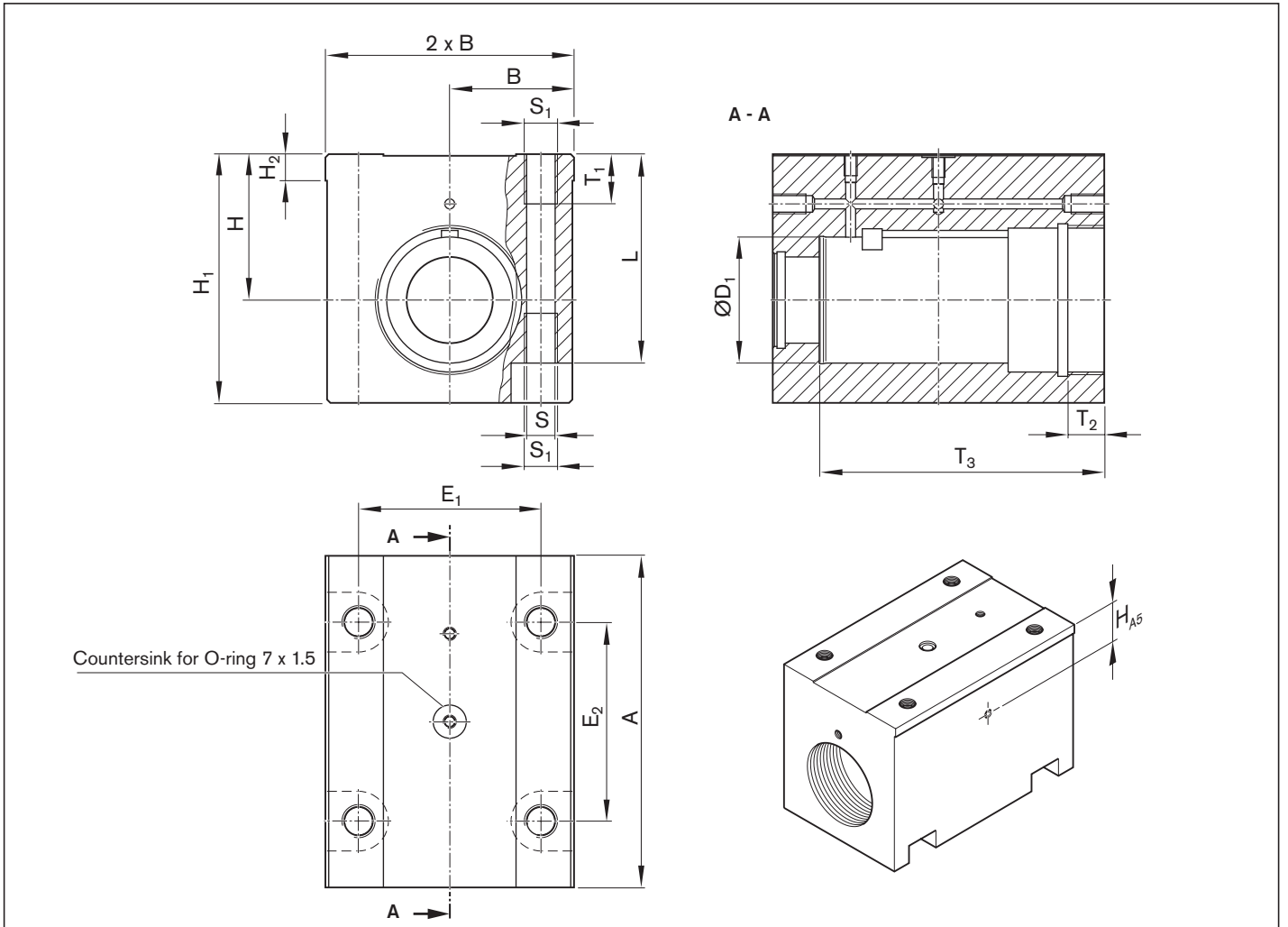

Ball screw assemblies BASA

(mm)														
A	B ±0.01	ØD ₁ H6	E ₁	E ₂	H ±0.01	H ₁	H ₂	H _{A5}	S	S ₁	T ₁	T ₂	T ₃	Clamping length L
100	37.5	38	55	60	44	75	8	15	8.6	M10	15	11	86	63
150	50.0	50	75	100	49	80	9	16	10.5	M12	18	15	131	66
180	60.0	63	90	120	59	105	10	18	14.5	M16	24	20	155	86

Pillow block unit SEC-F assembly, aluminum

Fixed bearing with angular-contact thrust ball bearing LGF-B-...

The pillow block unit consists of:

- Precision pillow block housing made of aluminum with reference edges on both sides
- Angular-contact thrust ball bearing LGF..
- Slotted nut NMZ

The slotted nut is delivered unmounted.

Separate technical dimensioning to determine the limit values is absolutely necessary for all attachments (e.g. pillow block units, bearing assembly, etc.)



Size	Complete pillow block	Angular-contact thrust ball bearing					Abbreviation	Slotted nut		Weight complete
		Load ratings (axial)		(mm)				M_A	Abbreviation	
$d_0 \times P$	Part number	dyn. C (N)	stat. C ₀ (N)	d	D	B	(Nm)		(kg)	
20x5/10/20/40	R1594 012 00	17,000	24,700	12	55	25	8.0	NMZ 12x1	1.49	
32x5/10/20/32/64	R1594 020 00	26,000	47,000	20	68	28	18.0	NMZ 20x1	1.88	
40x5/10/12/16/20/25/30/40	R1594 030 00	29,000	64,000	30	80	28	32.0	NMZ 30x1.5	2.75	

Screw end Form 81, 81A, 82, 82A designed for motor mounting.

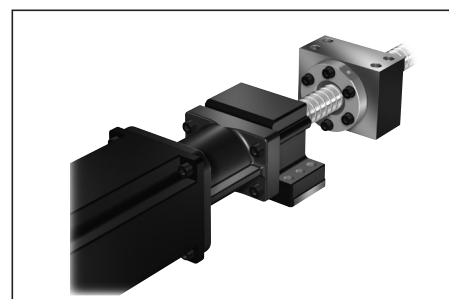
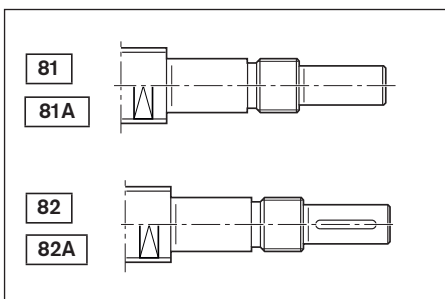

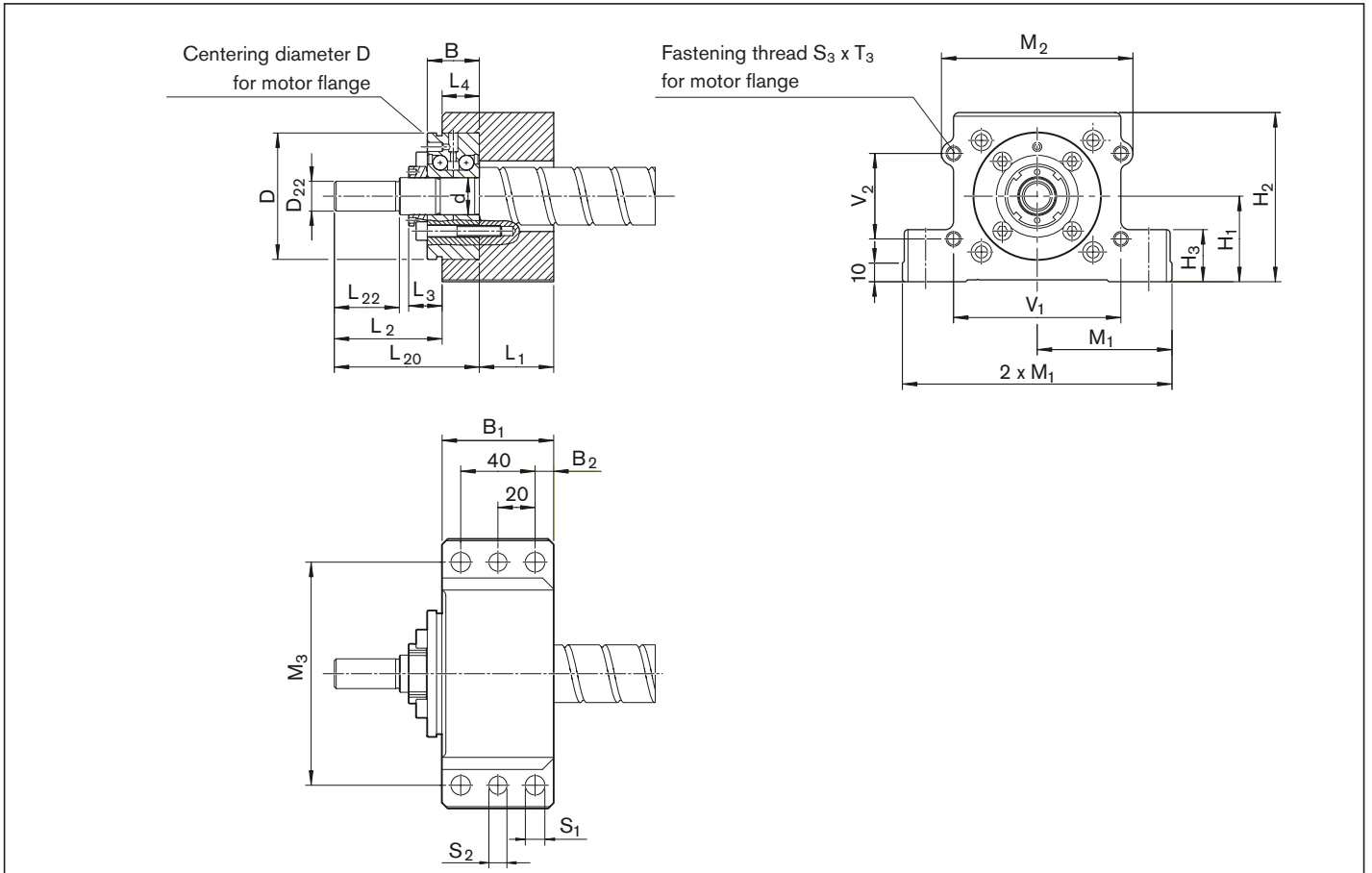

Ball screw assemblies BASA

Size	(mm)																					
	B ₁	B ₂	L ₁	L ₂	L ₃	L ₄	L ₂₀	L ₂₂	D ₂₂	M ₁	M ₂	M ₃	H ₁	H ₂	H ₃	S ₁	S ₂	S ₃	T ₃	V ₁	V ₂	
d ₀ x P										±0.015			±0.015									
20x5/10/20/40	60	10.0	42	42	15	18	60	25	10	72.5	80	120	41	81	28	10.5	9.7	M8	15	66	50	
32x5/10/20/32/64	60	10.0	40	58	18	20	78	35	16	72.5	103	120	46	91	28	10.5	9.7	M8	15	90	46	
40x5/10/12/16/20/25/30/40	65	12.5	45	73	20	20	93	50	25	90.0	116	150	56	111	33	13.0	11.7	M10	20	100	65	

Pillow block unit SEC-L assembly, aluminum

Floating bearing with DIN 625 deep-groove ball bearing

The pillow block unit consists of:

- Precision pillow block housing made of aluminum with reference edges on both sides
- Deep-groove ball bearing as per DIN 625
- Retaining ring DIN 471
- Cover

All parts are delivered unmounted.

Separate technical dimensioning to determine the limit values is absolutely necessary for all attachments (e.g. pillow block units, bearing assembly, etc.)

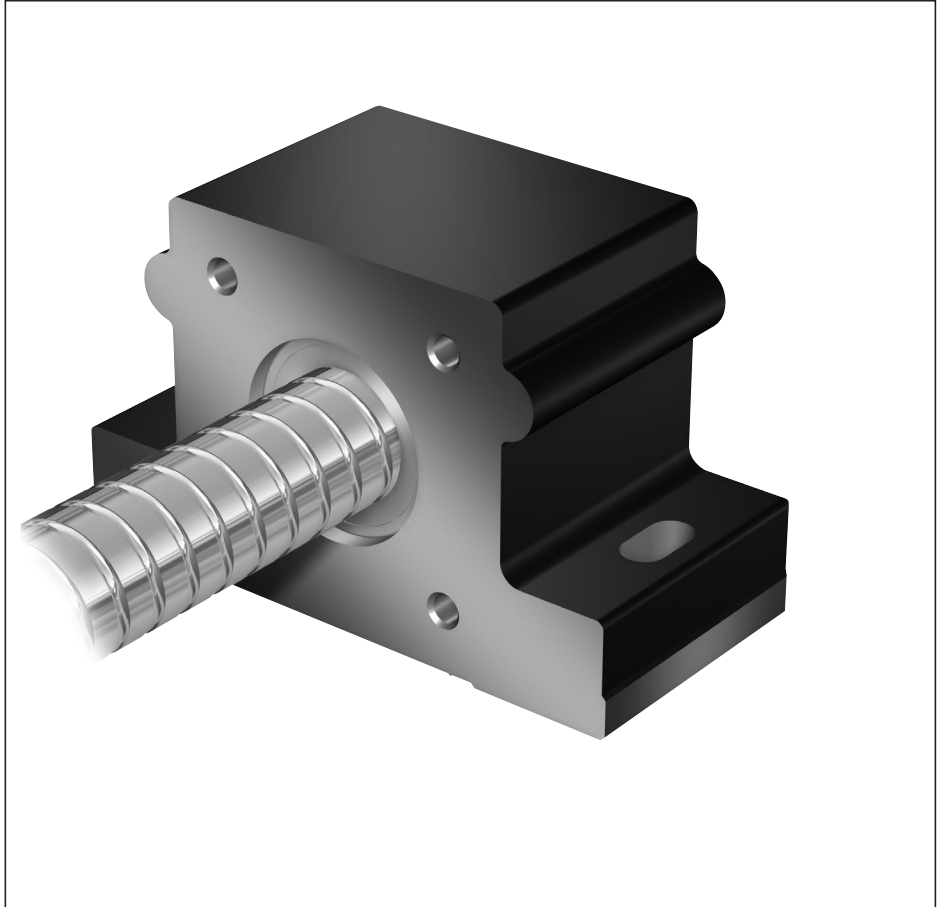

Size	Complete pillow block	Deep-groove ball bearing as per DIN 625					Designation DIN 625...	Retaining ring as per DIN 471	Weight complete (kg)
		Load ratings (radial)		(mm)					
$d_0 \times P$	Part number	dyn. C (N)	stat. C ₀ (N)	d	D	B			
20x5/10/20/40	R1594 615 00	7,800	3,250	15	35	11	6202.2RS	15x1	1.24
32x5/10/20/32/64	R1594 620 00	12,700	5,700	20	47	14	6204.2RS	20x1.2	1.66
40x5/10/12/16/20/25/30/40	R1594 630 00	19,300	9,800	30	62	16	6206.2RS	30x1.5	2.74

Suitable for screw ends: Form

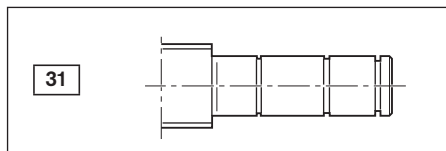

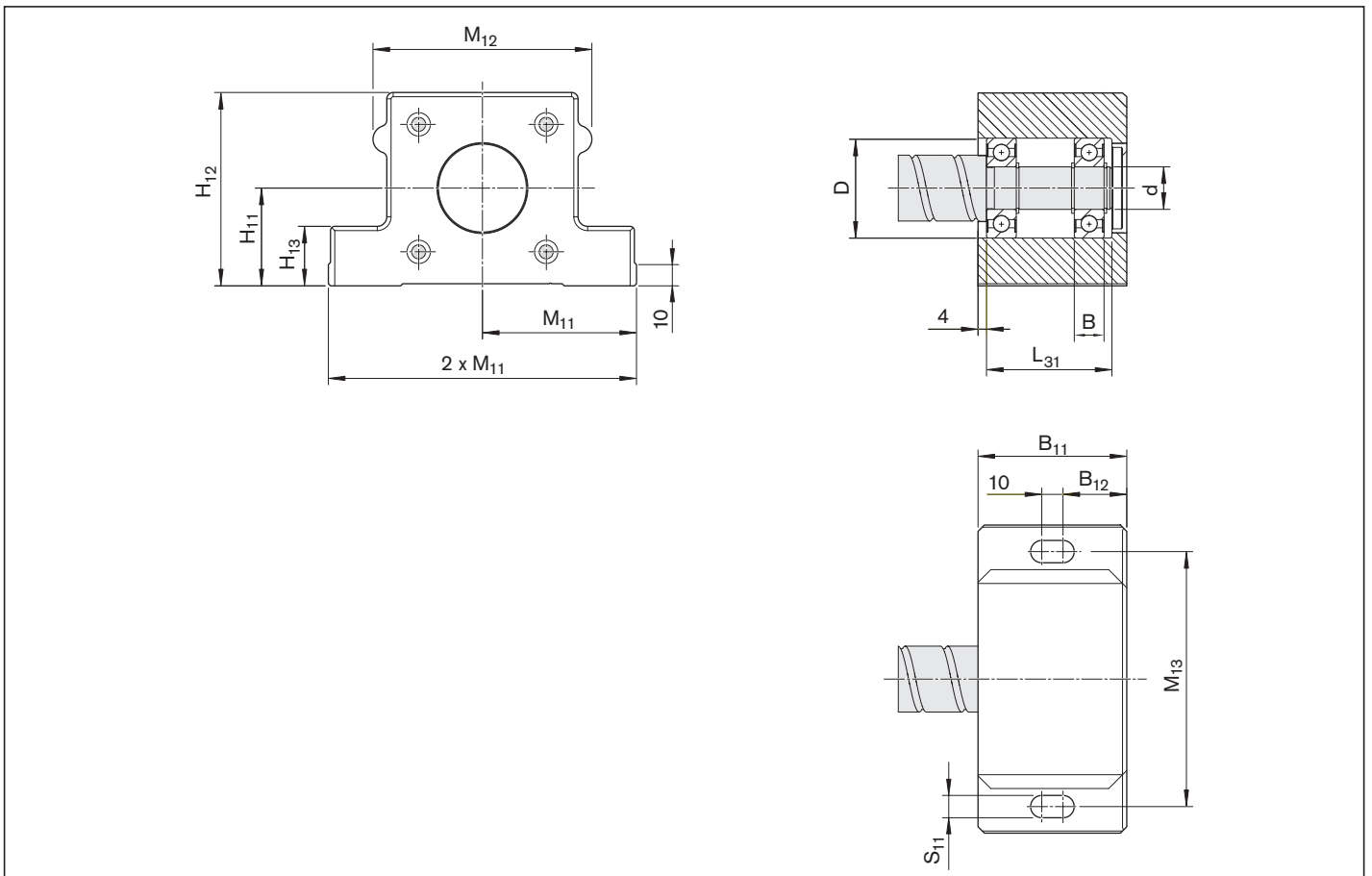

Size	(mm)										
	B ₁₁	B ₁₂	L ₃₁	M ₁₁ ±0.015	M ₁₂	M ₁₃	H ₁₁ ±0.015	H ₁₂	H ₁₃	S ₁₁	
d ₀ x P											
20x5/10/20/40	60	25	47	72.5	80	120	41	81	28	10.5	
32x5/10/20/32/64	70	30	60	72.5	103	120	46	91	28	10.5	
40x5/10/12/16/20/25/30/40	80	35	68	90.0	116	150	56	111	33	13.0	

Pillow block unit SES-F assembly, steel

Fixed bearing with angular-contact thrust ball bearing LGF-B-..., LGF-C-...

The pillow block unit consists of:

- Precision pillow block housing made of steel with reference edges on both sides
- Angular-contact thrust ball bearing LGF...
- Slotted nut NMZ

The slotted nut is delivered unmounted.

Separate technical dimensioning to determine the limit values is absolutely necessary for all attachments (e.g. pillow block units, bearing assembly, etc.)



Size $d_0 \times P$	Complete pillow block Part number	Angular-contact thrust ball bearing					Abbreviation	Slotted nut		Weight complete (kg)
		Load ratings (axial)		(mm)				M_A (Nm)	Abbreviation	
		dyn. C (N)	stat. C ₀ (N)	d	D	B				
20x5/10/20/40	R1595 012 20	17,000	24,700	12	55	25	LGF-B-1255	8	NMZ 12x1	3.37
25x5/10/25	R1595 017 20	18,800	31,000	17	62	25	LGF-B-1762	15	NMZ 17x1	3.38
32x5/10/20/32/64	R1595 020 20	26,000	47,000	20	68	28	LGF-B-2068	18	NMZ 20x1	4.31
40x5	R1595 030 20	29,000	64,000	30	80	28	LGF-B-3080	32	NMZ 30x1.5	6.31
40x10/12/16/20/25/30/40	R1595 330 20	47,500	127,000	30	80	56	LGF-C-3080	32	NMZ 30x1.5	7.53

Screw end Form 81, 81A, 82, 82A
designed for motor mounting.

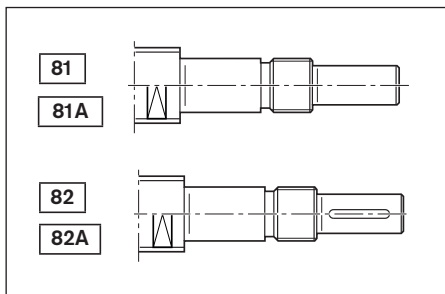

Further information on the bearing pair can be found on page 114.

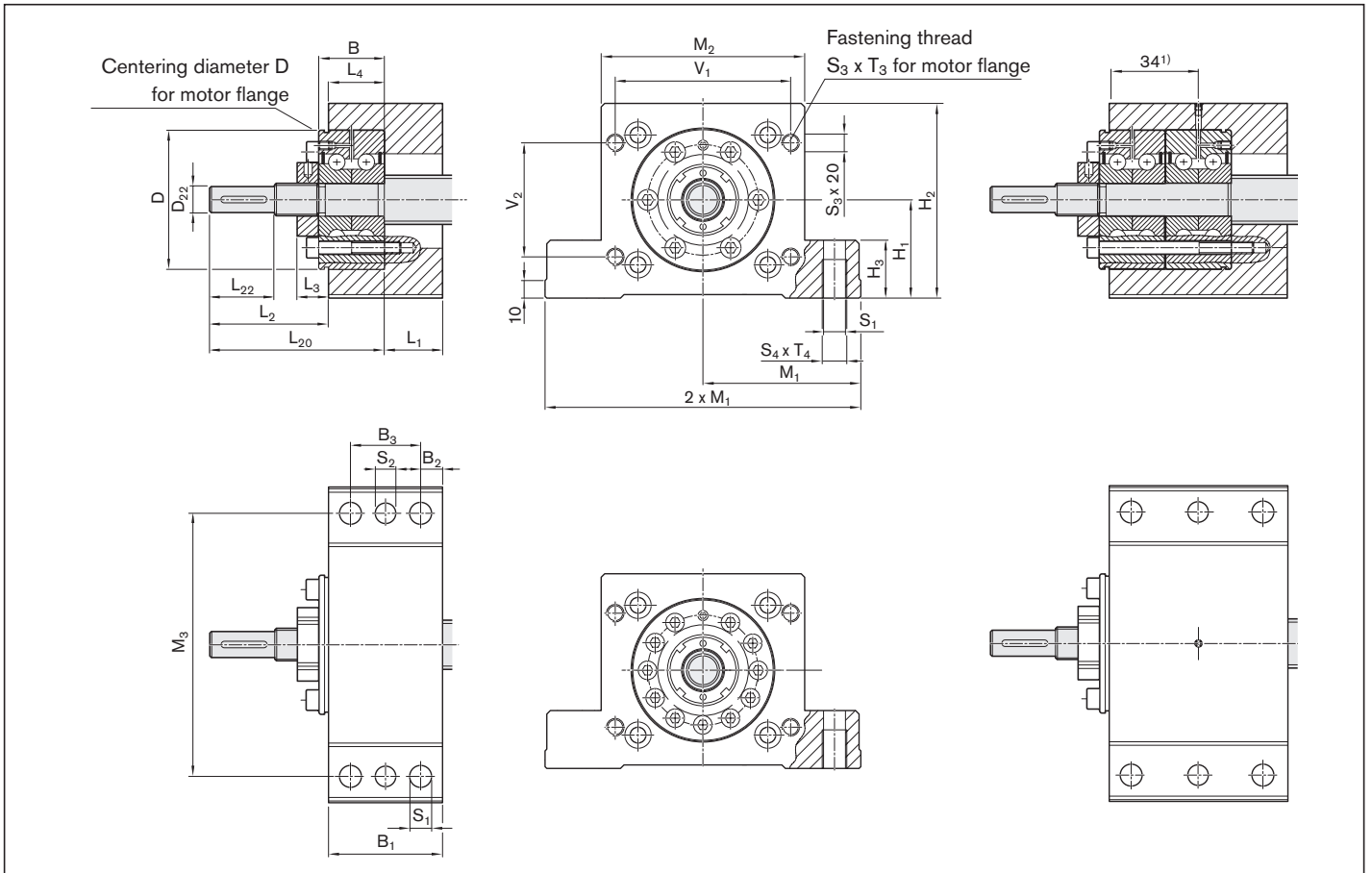

Size d ₀ xP	(mm)																								
	B ₁	B ₂	B ₃	L ₁	L ₂	L ₃	L ₄	L ₂₀	L ₂₂	D ₂₂	M ₁	M ₂	M ₃	H ₁	H ₂	H ₃	S ₁	S ₂	S ₃	S ₄	T ₃	T ₄	V ₁	V ₂	
20x5/10/20/40	60	10.0	40	42	42	15	18	60	25	10	±0.015	80	120	±0.015	41	81	28	10.5	9.7	M8	M12	20	20	66	50
25x5/10/25	60	10.0	40	42	57	17	18	75	30	15	±0.015	80	120	±0.015	41	81	28	10.5	9.7	M8	M12	20	20	66	50
32x5/10/20/32/64	60	10.0	40	40	58	18	20	78	35	16	±0.015	103	120	±0.015	46	91	28	10.5	9.7	M8	M12	20	20	90	46
40x5	65	12.5	40	45	73	20	20	93	50	25	±0.015	116	150	±0.015	56	111	33	12.5	11.7	M10	M14	20	22	100	65
40x10/12/16/20/25/30/40	85	12.5	60	37	82	20	48	130	50	25	±0.015	116	150	±0.015	56	111	33	12.5	11.7	M10	M14	20	22	100	65

1) With part number R1595 330 20 only

Pillow block unit SES-L assembly, steel

Floating bearing with DIN 625 deep-groove ball bearing

The pillow block unit consists of:

- Precision pillow block housing made of steel with reference edges on both sides
- Deep-groove ball bearing as per DIN 625
- Retaining ring DIN 471
- Cover

All parts are delivered unmounted.

Separate technical dimensioning to determine the limit values is absolutely necessary for all attachments (e.g. pillow block units, bearing assembly, etc.)



Size	Complete pillow block	Deep-groove ball bearing as per DIN 625					Designation DIN 625...	Retaining ring as per DIN 471	Weight complete (kg)
		Load ratings (radial)		(mm)					
$d_0 \times P$	Part number	dyn. C (N)	stat. C ₀ (N)	d	D	B			
20x5/10/20/40	R1595 615 00	7,800	3,250	15	35	11	6202.2RS	15x1	3.26
25x5/10/25	R1595 617 00	9,500	4,150	17	40	12	6203.2RS	17x1	3.39
32x5/10/20/32/64	R1595 620 00	12,700	5,700	20	47	14	6204.2RS	20x1.2	4.74
40x5/10/12/16/20/25/30/40	R1595 630 00	19,300	9,800	30	62	16	6206.2RS	30x1.5	7.30

Suitable for screw ends: Form

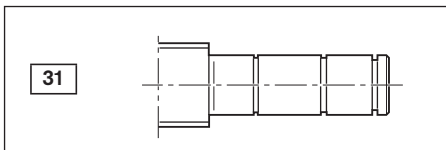

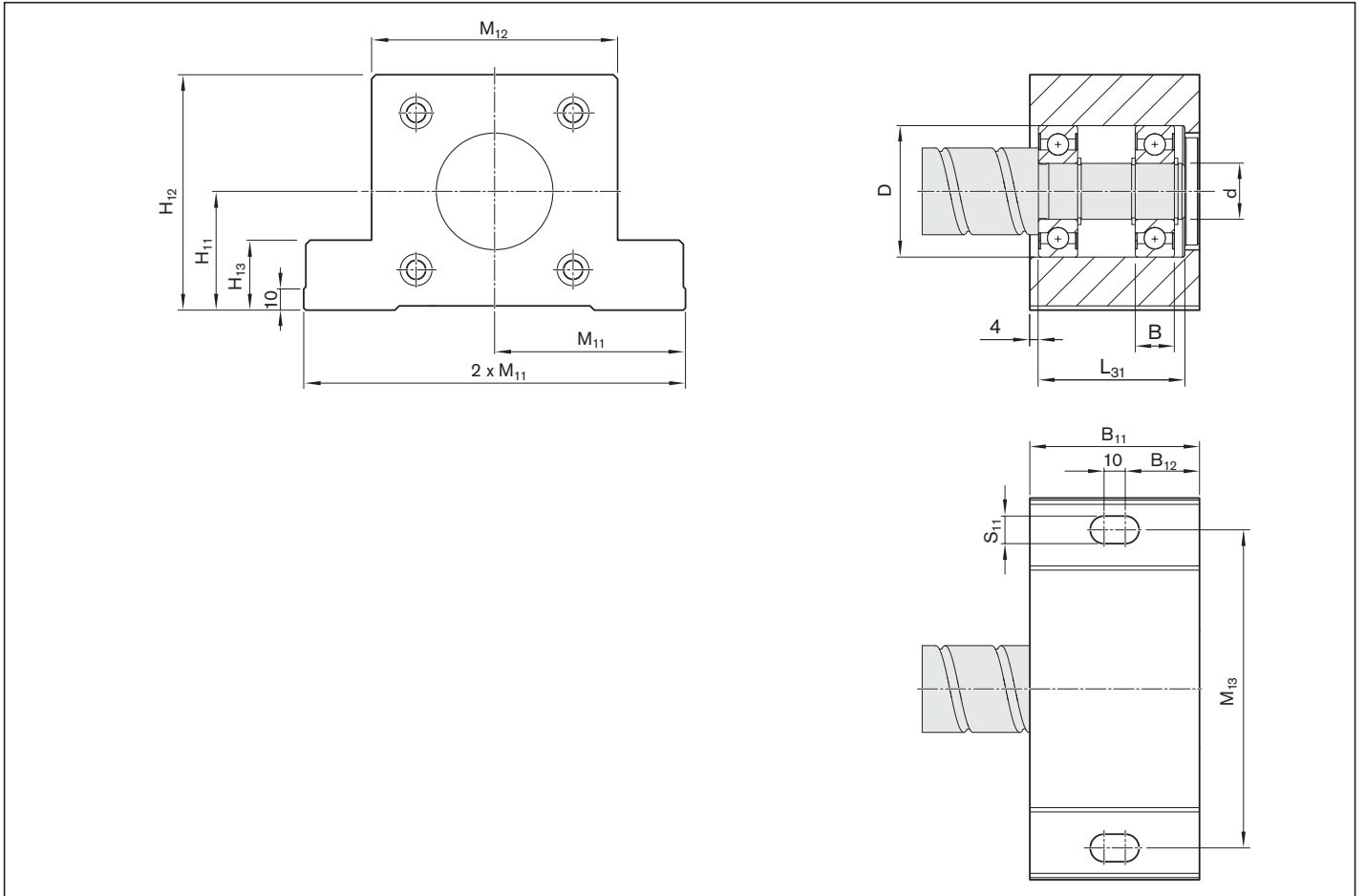

Size	(mm)									
	B ₁₁	B ₁₂	L ₃₁	M ₁₁ ±0.015	M ₁₂	M ₁₃	H ₁₁ ±0.015	H ₁₂	H ₁₃	S ₁₁
d ₀ x P										
20x5/10/20/40	60	25.0	47	72.5	80	120	41	81	28	10.5
25x5/10/25	64	27.0	51	72.5	80	120	41	81	28	10.5
32x5/10/20/32/64	70	30.0	60	72.5	103	120	46	91	28	10.5
40x5/10/12/16/20/25/30/40	80	35.0	68	90.0	116	150	56	111	33	13.0

Pillow block unit SEB-F assembly

Fixed bearing with angular-contact thrust ball bearing LGN-B-... LGN-C-...

The pillow block unit consists of:

- Precision pillow block housing made of steel with reference edges on both sides
- Angular-contact thrust ball bearing LGN
- Slotted nut NMA or NMZ
- Ring nut GWR

The slotted nut is delivered unmounted.

Separate technical dimensioning to determine the limit values is absolutely necessary for all attachments (e.g. pillow block units, bearing assembly, etc.)

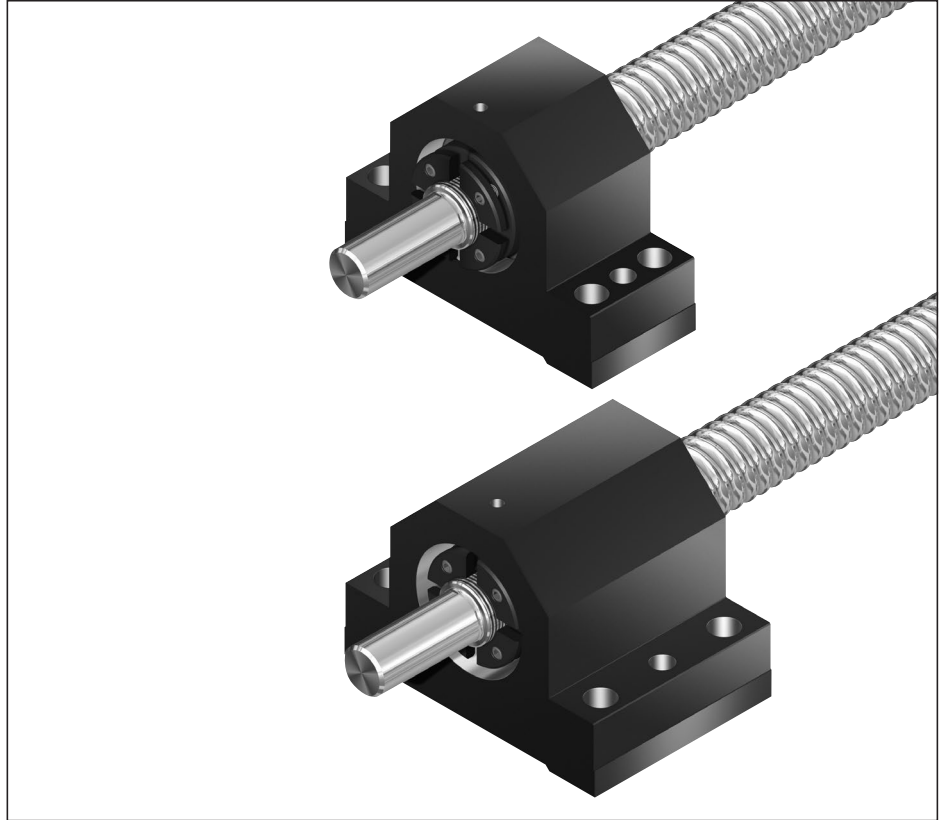

Size $d_0 \times P$	Complete pillow block Part number	Angular-contact thrust ball bearing			Slotted nut			Weight complete (kg)		
		Load ratings (axial)		Dimensions (mm)			Abbreviation			
		dyn. C (N)	stat. C ₀ (N)	d	D	B	M _A (Nm)			
6 x 1/2	R1591 106 00	6,900	8,500	6	24	15	LGN-B-0624	2.0	NMZ 6x0.5	0.38
8 x 1/2/2.5/5	R1591 106 00	6,900	8,500	6	24	15	LGN-B-0624	2.0	NMZ 6x0.5	0.38
12 x 2/5/10	R1591 106 20	6,900	8,500	6	24	15	LGN-B-0624	2.0	NMZ 6x0.5	0.38
16 x 5/10/16	R1591 110 20	13,400	18,800	10	34	20	LGN-B-1034	6.0	NMZ 10x1	0.87
20 x 5/10/20/40	R1591 112 20	17,000	24,700	12	42	25	LGN-B-1242	8.0	NMZ 12x1	1.12
25 x 5/10/25	R1591 117 20	18,800	31,000	17	47	25	LGN-B-1747	15.0	NMZ 17x1	1.65
25 x 5/10/25	R1591 117 30	18,800	31,000	17	47	25	LGN-B-1747	15.0	NMA 17x1	1.69
32 x 5/10/20/32/64	R1591 120 20	26,000	47,000	20	52	28	LGN-B-2052	18.0	NMZ 20x1	1.93
32 x 5/10/20/32/64	R1591 120 30	26,000	47,000	20	52	28	LGN-B-2052	18.0	NMA 20x1	2.03
40 x 10/12/16/20/25/30/40	R1591 225 30	44,500	111,000	25	57	56	LGN-C-2557	25.0	NMA 25x1.5	5.13
40 x 5	R1591 130 20	29,000	64,000	30	62	28	LGN-B-3062	32.0	NMZ 30x1.5	2.64
40 x 5	R1591 130 30	29,000	64,000	30	62	28	LGN-B-3062	32.0	NMA 30x1.5	2.77
50 x 5	R1591 135 30	41,000	89,000	35	72	34	LGN-B-3572	40.0	NMA 35x1.5	4.66
50 x 10/12/16/20/25/30/40	R1591 230 30	47,500	127,000	30	62	56	LGN-C-3062	32.0	NMA 30x1.5	7.04
63 x 10/20/40	R1591 140 30	72,000	149,000	40	90	46	LGN-A-4090	55.0	NMA 40x1.5	10.49
80 x 10/20/40	R1591 150 30	113,000	250,000	50	110	54	LGN-A-50110	85.0	NMA 50x1.5	15.61

Suitable for screw ends: Form

For screws 6 x 1/2: Form 831

For screws 8 x 1/2/2.5/5: Form 831, 931

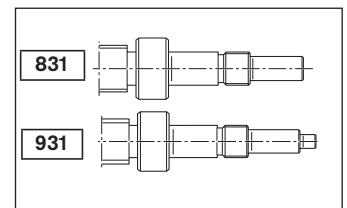
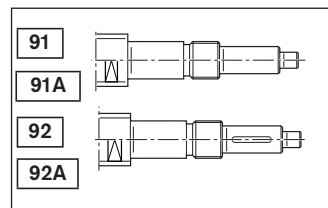
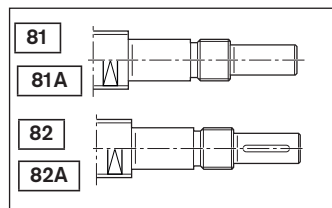
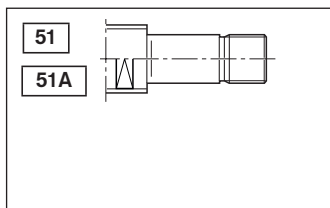

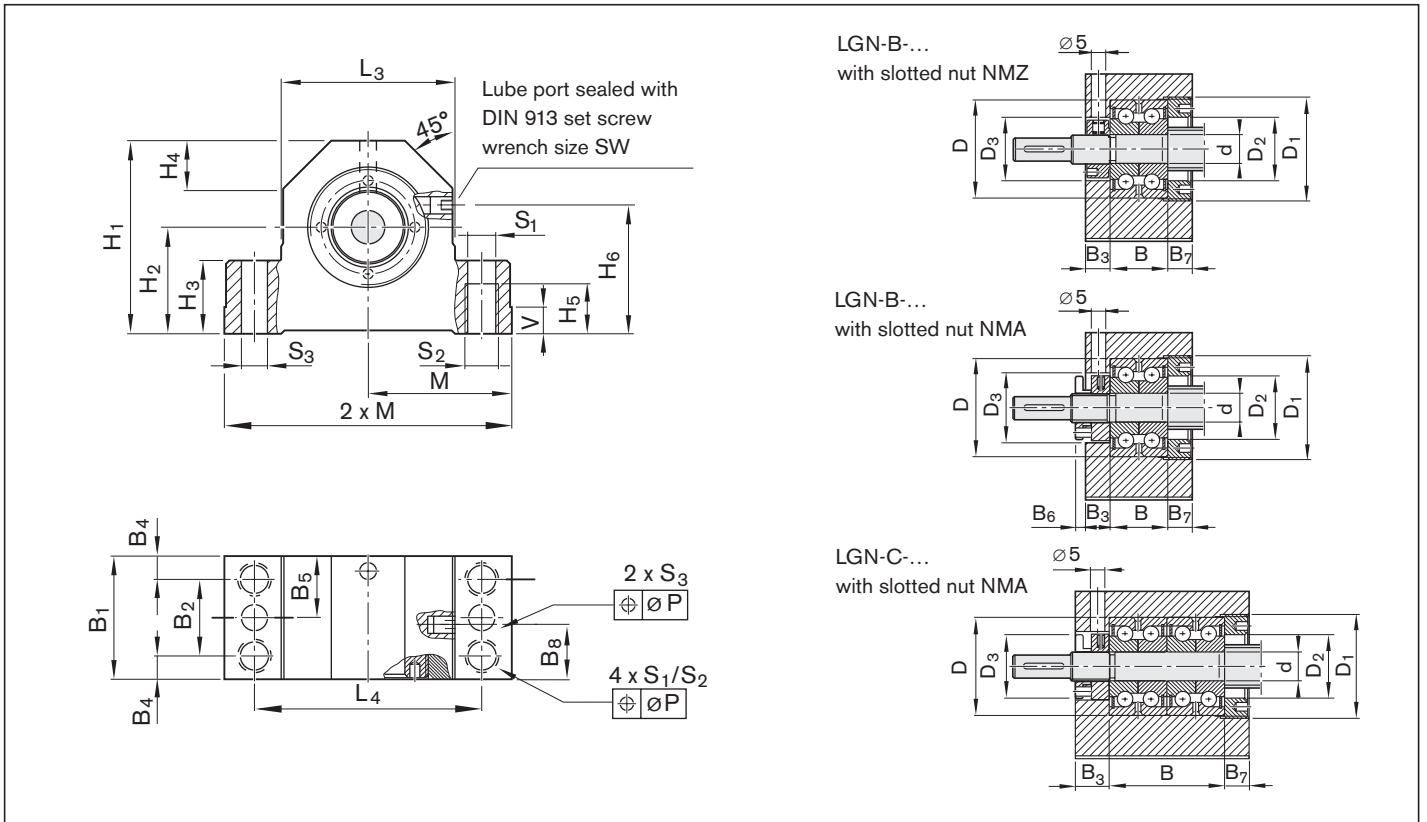

Size	(mm)																									
	M	L ₃	L ₄	H ₁	H ₂	H ₃	H ₄	H ₅	H ₆	B ₁	B ₂	B ₃	B ₄	B ₅	B ₆	B ₇	B ₈	V	S ₁	S ₂	S ₃	SW	D ₁	D ₂	D ₃	P
d ₀ x P	js7				±0.02														H12							
6 x 1/2	31.0	38	50	34	18	13	8	9	22	32	16	8.5	8.0	16.0	-	8.5	16.0	6	5.3	M6	3.7	3	M26x1.5	16.5	18	0.10
8 x 1/2/2.5/5	31.0	38	50	34	18	13	8	9	22	32	16	8.5	8.0	16.0	-	8.5	16.0	6	5.3	M6	3.7	3	M26x1.5	16.5	18	0.10
12 x 2/5/10	31.0	38	50	41	22	13	8	9	22	32	16	8.5	8.0	16.0	-	8.5	16.0	6	5.3	M6	3.7	3	M26x1.5	16.5	18	0.10
16 x 5/10/16	43.0	52	68	58	32	22	14	15	37	37	23	8.5	7.0	18.5	-	8.5	18.5	8	8.4	M10	7.7	4	M36x1.5	22.0	27	0.15
20 x 5/10/20/40	47.0	60	77	64	34	22	16	15	40	42	25	8.5	8.5	21.0	-	8.5	21.0	8	8.4	M10	7.7	4	M45x1.5	28.0	32	0.15
25 x 5/10/25	54.0	66	88	72	39	27	18	18	45	46	29	10.5	8.5	23.0	-	10.5	23.0	10	10.5	M12	9.7	4	M50x1.5	31.0	36	0.20
25 x 5/10/25	54.0	66	88	72	39	27	18	18	45	46	29	10.5	8.5	23.0	7.5	10.5	23.0	10	10.5	M12	9.7	4	M50x1.5	31.0	36	0.20
32 x 5/10/20/32/64	56.0	70	92	77	42	27	19	18	48	49	29	10.5	10.0	24.5	-	10.5	24.5	10	10.5	M12	9.7	4	M55x1.5	36.0	42	0.20
32 x 5/10/20/32/64	56.0	70	92	77	42	27	19	18	48	49	29	10.5	10.0	24.5	7.5	10.5	24.5	10	10.5	M12	9.7	4	M55x1.5	36.0	42	0.20
40 x 10/12/16/20/25/30/40	63.0	80	105	98	58	32	23	21	64	89	62	20.5	13.5	44.5	-	12.5	54.5	12	12.6	M14	9.7	4	M62x1.5	43.0	48	0.20
40 x 5	63.0	80	105	90	50	32	22	21	56	53	32	12.5	10.5	26.5	-	12.5	26.5	12	12.6	M14	9.7	4	M65x1.5	47.0	53	0.20
40 x 5	63.0	80	105	90	50	32	22	21	56	53	32	12.5	10.5	26.5	7.5	12.5	26.5	12	12.6	M14	9.7	4	M65x1.5	47.0	53	0.20
50 x 5	72.0	92	118	105	58	38	25	22	63	70	43	20.5	13.5	35.0	-	15.5	32.5	12	12.5	M14	9.7	4	M78x2	54.0	60	0.20
50 x 10/12/16/20/25/30/40	72.0	92	118	112	65	38	25	22	70	92	65	20.5	13.5	46.0	-	15.5	57.5	12	12.5	M14	9.7	4	M78x2	54.0	53	0.20
63 x 10/20/40	95.0	130	160	138	73	50	35	22	78	85	58	22.5	13.5	42.5	-	16.5	39.5	16	12.5	M14	9.7	4	M95x2	68.0	72	0.20
80 x 10/20/40	102.5	145	175	165	93	50	40	36	98	98	58	25.5	20.0	49.0	-	18.5	45.5	16	17.3	M20	11.7	4	M115x2	85.0	90	0.20

Pillow block unit SEB-L assembly

Floating bearing with DIN 625 deep-groove ball bearing

The pillow block unit consists of:

- Precision pillow block housing made of steel with reference edge on one side
- Deep-groove ball bearing as per DIN 625
- Retaining ring DIN 471
- Cover

All parts are delivered unmounted.

Separate technical dimensioning to determine the limit values is absolutely necessary for all attachments (e.g. pillow block units, bearing assembly, etc.)

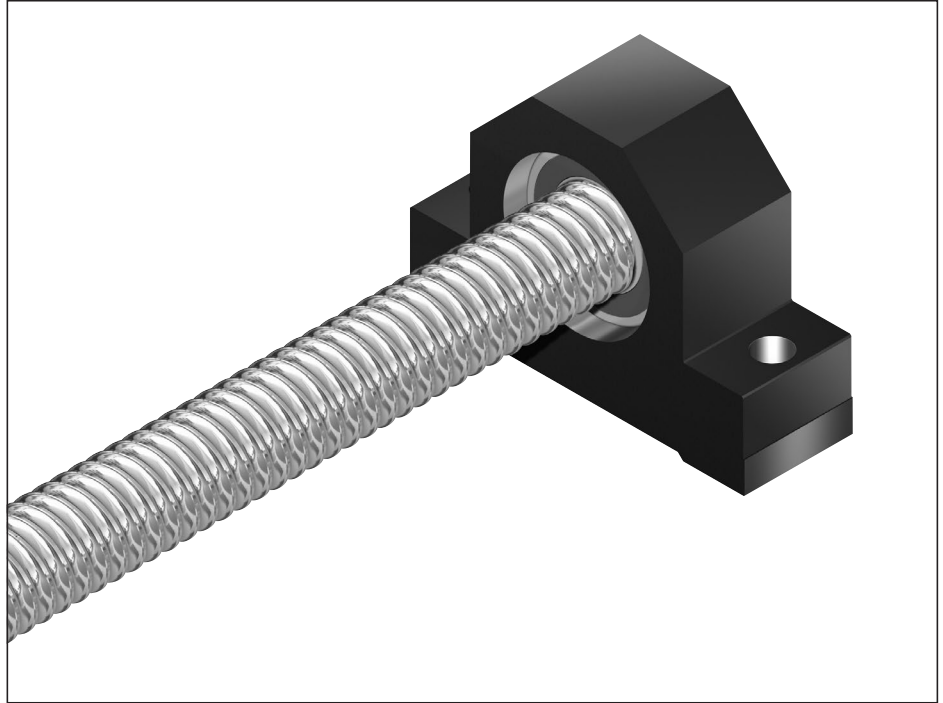

Size $d_0 \times P$	Complete pillow block Part number	Deep-groove ball bearing as per DIN 625 Load ratings (radial) (mm)					Designation DIN 625...	Retaining ring as per DIN 471	Weight complete (kg)
		dyn. C (N)	stat. C ₀ (N)	d	D	B			
8 x 1/2/2.5/5	R1591 605 00	1,900	590	5	16	5	625.2RS	5x0.6	0.14
12 x 2/5/10	R1591 606 20	2,450	900	6	19	6	626.2RS	6x0.7	0.18
16 x 5/10/16	R1591 610 20	6,000	2,240	10	30	9	6200.2RS	10x1	0.54
20 x 5/10/20/40	R1591 612 20	6,950	2,650	12	32	10	6201.2RS	12x1	0.73
25 x 5/10/25	R1591 617 20	9,500	4,150	17	40	12	6203.2RS	17x1	0.96
32 x 5/10/20/32/64	R1591 620 20	12,700	5,700	20	47	14	6204.2RS	20x1.2	1.24
40 x 5	R1591 630 20	19,300	9,800	30	62	16	6206.2RS	30x1.5	1.66
40 x 10/12/16/20/25/30/40	R1591 630 10	19,300	9,800	30	62	16	6206.2RS	30x1.5	1.82
50 x 5 ¹⁾	R1591 635 10	25,500	13,200	35	72	17	6207.2RS	35x1.5	2.66
50 x 10/12/16/20/25/30/40 ¹⁾	R1591 635 20	25,500	13,200	35	72	17	6207.2RS	35x1.5	2.87
63 x 10/20/40 ¹⁾	R1591 650 20	36,500	20,800	50	90	20	6210.2RS	50x2	5.39
80 x 10/20/40 ¹⁾	R1591 660 20	52,000	31,000	60	110	22	6212.2RS	60x2	7.09

1) without cover

Suitable for screw ends: Form

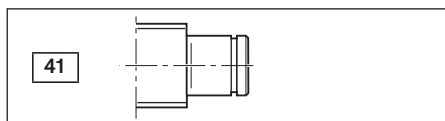

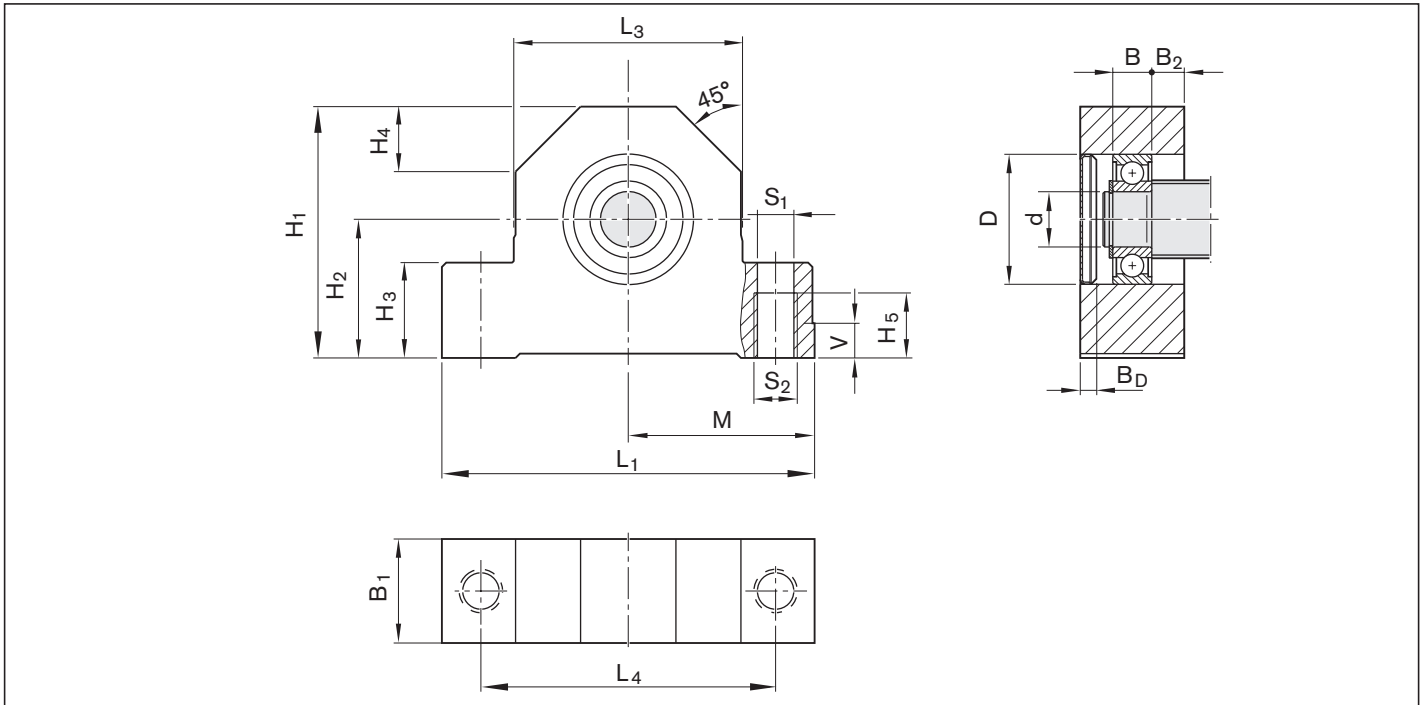

Size	(mm)															
	L_1	L_3	L_4	H_1	H_2 ± 0.02	H_3	H_4	H_5	B_1	B_2	M $js7$	V	S_1 $H12$	S_2	Cover B_D	
$8 \times 1/2/2.5/5$	62	38	50	34	18	13	11	9	13	4.0	31.0	6	5.3	M6	2.6	
$12 \times 2/5/10$	62	38	50	41	22	13	11	9	15	4.5	31.0	6	5.3	M6	2.6	
$16 \times 5/10/16$	86	52	68	58	32	22	15	15	24	7.5	43.0	8	8.4	M10	3.8	
$20 \times 5/10/20/40$	94	60	77	64	34	22	17	15	26	8.0	47.0	8	8.4	M10	3.8	
$25 \times 5/10/25$	108	66	88	72	39	27	19	18	28	8.0	54.0	10	10.5	M12	3.7	
$32 \times 5/10/20/32/64$	112	70	92	77	42	27	20	18	34	10.0	56.0	10	10.5	M12	4.8	
40×5	126	80	105	90	50	32	23	21	38	11.0	63.0	12	12.6	M14	4.5	
$40 \times 10/12/16/20/25/30/40$	126	80	105	98	58	32	23	21	38	11.0	63.0	12	12.6	M14	4.5	
50×5	144	92	118	105	58	38	25	22	41	12.0	72.0	12	12.5	M14	-	
$50 \times 10/12/16/20/25/30/40$	144	92	118	112	65	38	25	22	41	12.0	72.0	12	12.5	M14	-	
$63 \times 10/20/40$	190	130	160	138	73	50	35	22	46	13.0	95.0	16	12.5	M14	-	
$80 \times 10/20/40$	205	145	175	165	93	50	40	36	50	14.0	102.5	16	17.3	M20	-	

Flange bearing assembly SEE-F-Z

Fixed bearing with angular-contact thrust ball bearing

The bearing assembly consists of:

- precision flanged housing made of steel
- 2 pre-tensioned angular-contact thrust ball bearings
- Slotted nut
- Cover
- Radial shaft seal

Separate technical dimensioning to determine the limit values is absolutely necessary for all attachments (e.g. pillow block units, bearing assembly, etc.)



Size	Complete pillow block	Angular-contact thrust ball bearing				Slotted nut			
		dyn. C	stat. C ₀	max. axial load	(mm)	d	D	B	M _A (Nm)
d ₀	Part number	(N)	(N)	(N)					
25	R159751700	25,900	40,500	32,000	17	47	30	15	
32	R159752000	25,900	40,500	32,000	20	47	30	18	
10	R159752500	29,900	58,500	46,400	25	62	30	25	
40	R159753000	29,900	58,500	46,400	30	62	30	32	

Form	Version ¹⁾	Size (mm)										Centering Hole		Hex Socket		Threat	
		d ₀	P	L _{ff}	D ₁ h6	L ₁	D ₂ h7	L ₂	G ₁	LG ₁	Z	t _z	S	t _s	G	t _g	
81/81A	176	25	5/10/25	110.0	17	58.0	12	29.0	M17x1	23.0	M4	10.0	4	4	M5	8	
	207	32	5/10/20/32/64	120.0	20	58.0	15	39.0	M20x1	23.0	M5	12.0	4	4	M6	9	
	252	40	5/10/12/16/20/25/30/40	140.0	25	63.0	20	51.0	M25x1.5	26.0	M6	16.0	5	5	M8	12	
	311	40	5/10/12/16/20/25/30/40	150.0	30	63.0	25	61.0	M30x1.5	26.0	M10	22.0	8	8	M10	15	

1) The allocation of screw ends to the bearing assemblies is clearly defined by the version

Suitable for screw ends: Form

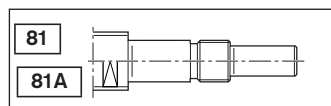

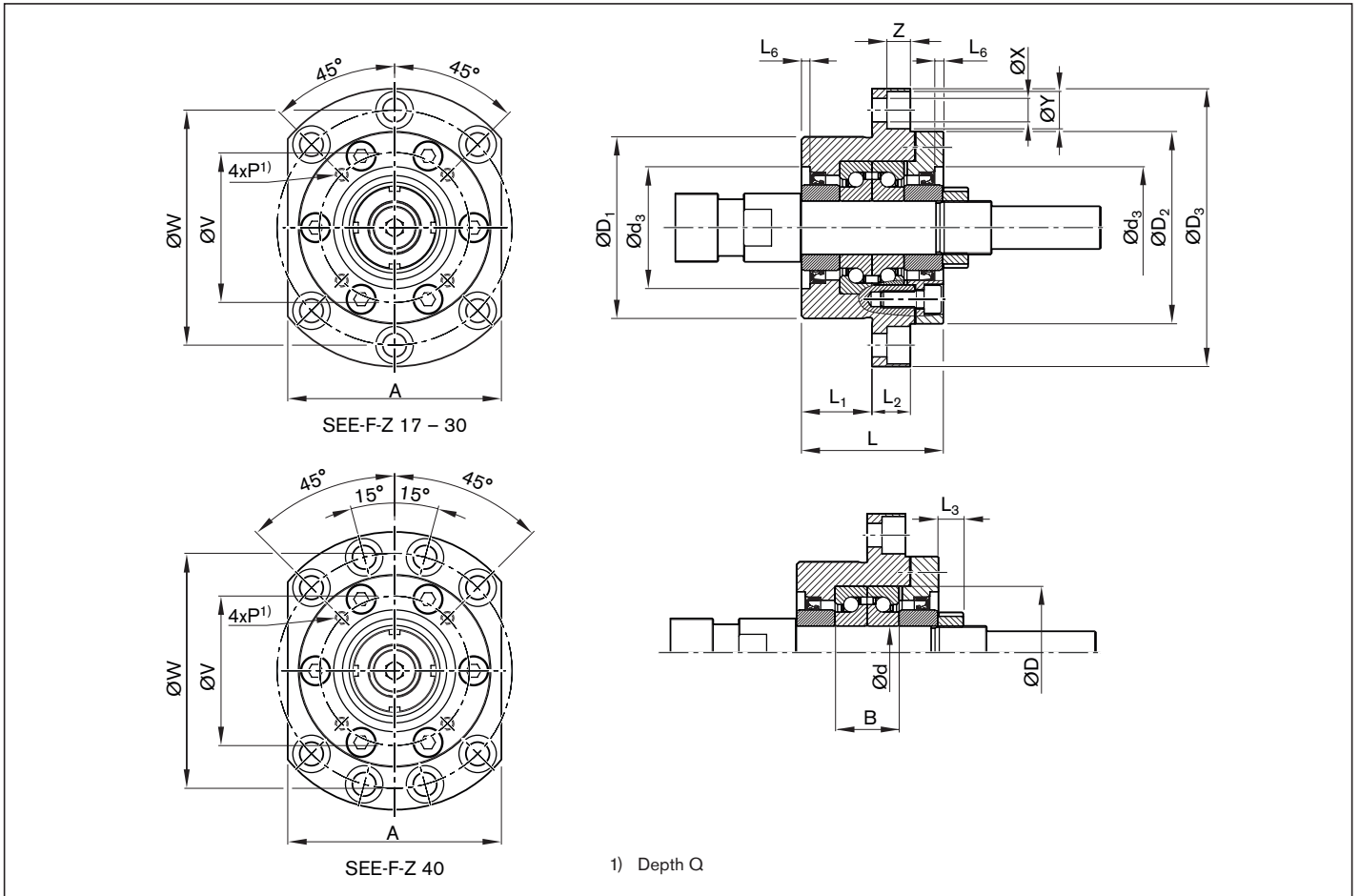

Size	(mm)																	Weight complete m (kg)
	d_0	D_1	D_2	D_3	L	L_1	L_2	L_3	A	d_3	L_6	W	X	Y	Z	V	P	
		g6								H8								
25	70	72	106	60	32	15	10	80	45	3	88	9	14.0	8.5	58	M5	10	1.84
32	70	72	106	60	32	15	10	80	45	3	88	9	14.0	8.5	58	M5	10	1.81
40	85	90	130	66	33	18	12	100	57	4	110	11	17.5	11.0	70	M6	12	3.13
40	85	90	130	66	33	18	12	100	57	4	110	11	17.5	11.0	70	M6	12	3.03

Version	Wrench size		
	SW	b_{SW}	l_{SW}
176	19	10	10.5
207	24	15	10.5
252	30	15	12.5
311	30	15	45.0

Bearing assembly LAF

Fixed bearing with angular-contact thrust ball bearing LGF

Double-thrust, screw-down,

series LGF-B-...

LGF-A-...

Double-thrust, screw-on,

Series LGF-C-...

The fixed bearing consists of:

- Angular-contact thrust ball bearing LGF
- Slotted nut NMA..., NMZ...

Separate technical dimensioning to determine the limit values is absolutely necessary for all attachments (e.g. pillow block units, bearing assembly, etc.)

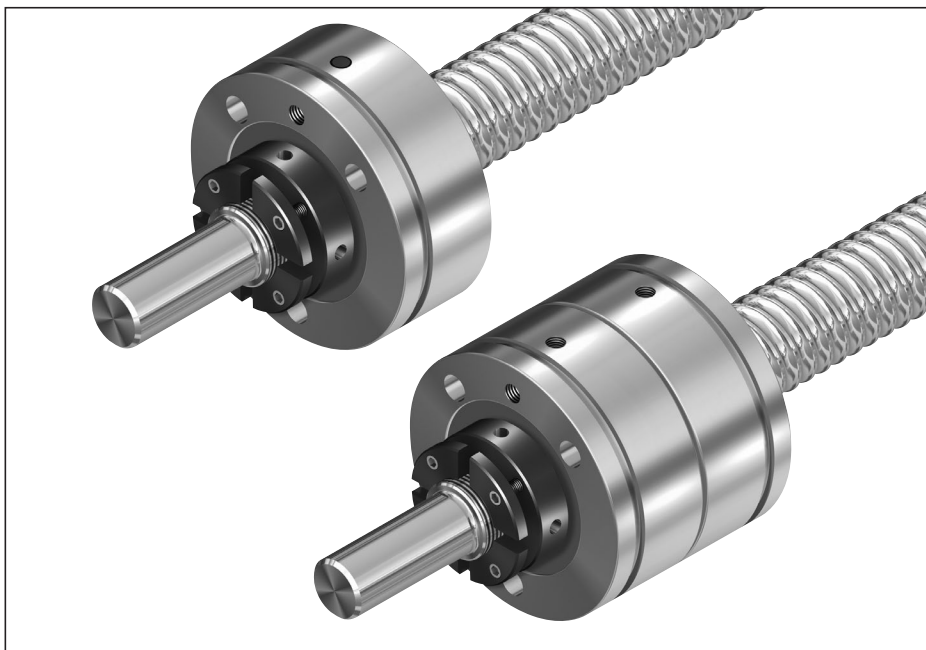

Size	Module	Single parts				Weight complete
		Angular-contact thrust ball bearing		Slotted nut		
$d_0 \times P$	Part number	Abbreviation	Part number	Abbreviation	Part number	(kg)
20 x 5/10/20/40	R1590 012 00	LGF-B-1255	R3414 009 06	NMZ 12x1	R3446 003 04	0.385
25 x 5/10/25	R1590 017 00	LGF-B-1762	R3414 010 06	NMZ 17x1	R3446 004 04	0.485
	R1590 017 30			NMA 17x1	R3446 014 04	0.520
32 x 5/10/20/32/64	R1590 020 00	LGF-B-2068	R3414 001 06	NMZ 20x1	R3446 005 04	0.645
	R1590 020 30			NMA 20x1	R3446 015 04	0.740
40 x 5	R1590 030 00	LGF-B-3080	R3414 011 06	NMZ 30x1.5	R3446 006 04	0.855
	R1590 030 30			NMA 30x1.5	R3446 016 04	0.980
40 x 10/12/16/20/25/30/40	R1590 325 30	LGF-C-2575	R3414 015 06	NMA 25x1.5	R3446 011 04	1.600
50 x 5	R1590 035 30	LGF-B-3590	R3414 026 06	NMA 35x1.5	R3446 012 04	1.360
50 x 10/12/16/20/25/30/40	R1590 330 30	LGF-C-3080	R3414 027 06	NMA 30x1.5	R3446 016 04	1.760
63 x 10/20/40	R1590 040 30	LGF-B-40115	R3414 028 06	NMA 40x1.5	R3446 018 04	2.500
80 x 10/20/40	R1590 050 30	LGF-A-50140	R3414 029 06	NMA 50x1.5	R3446 019 04	5.130

Size	Load ratings ¹⁾		Bearing friction torque with sealing disk	Rigidity (axial)	Rigidity against tilting	Limit speed (grease)
	dyn. C (N)	stat. C ₀ (N)				
20x5/10/20/40	17,000	24,700	0.16	375	50	3,800
25x5/10/25	18,800	31,000	0.24	450	80	3,300
32x5/10/20/32/64	26,000	47,000	0.30	650	140	3,000
40x5	29,000	64,000	0.50	850	300	2,200
40 x 10/12/16/20/25/30/40	44,500	111,000	0.60	1 300	450	2,600
50x5	41,000	89,000	0.60	900	400	2,000
50 x 10/12/16/20/25/30/40	47,500	127,000	0.75	1 500	620	2,200
63x10/20/40	72,000	149,000	1.30	1 200	750	1,600
80x10/20/40	113,000	250,000	2.60	1 400	1 500	1,200

1) See page 187 for load on bearing

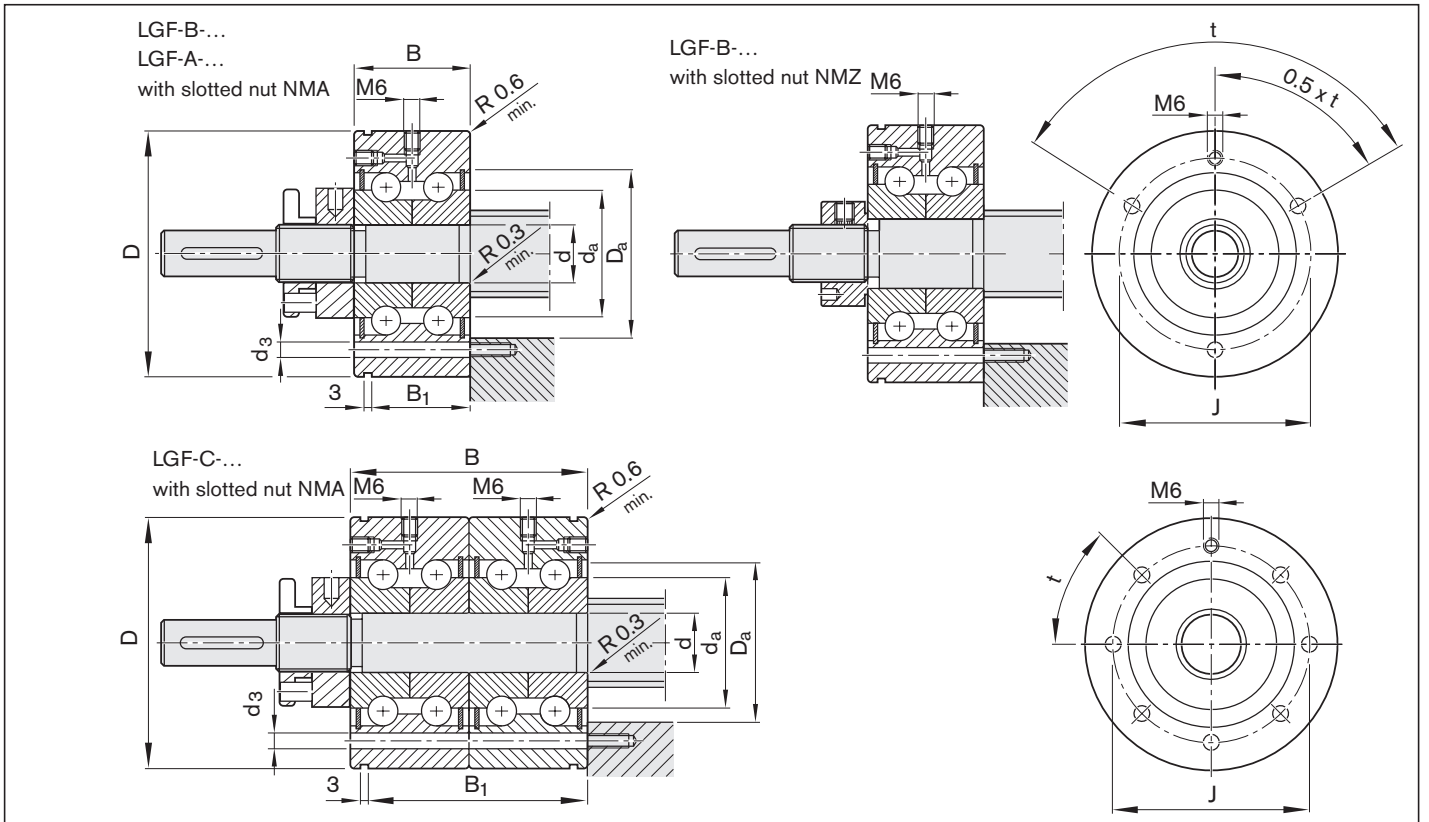

Ball screw assemblies BASA

Size $d_0 \times P$	Dimensions (mm)				Mounting dimensions (mm)					Mounting holes		
	d	D	B	B ₁	J	min	D _a max	min	d _a max	Minimum number ¹⁾	d ₃ (mm)	t (°)
20x5/10/20/40	12 _{-0.010}	55 _{-0.013}	25 _{-0.25}	17	42	30	33	16	29	3	6.8	120
25x5/10/25	17 _{-0.010}	62 _{-0.013}	25 _{-0.25}	17	48	34	37	23	33	3	6.8	120
32x5/10/20/32/64	20 _{-0.010}	68 _{-0.013}	28 _{-0.25}	19	53	40	43	25	39	4	6.8	90
40x5	30 _{-0.010}	80 _{-0.013}	28 _{-0.25}	19	63	50	53	40	49	6	6.8	60
40 x 10/12/16/20/25/30/40	25 _{-0.005}	75 _{-0.010}	56 _{-0.50}	47	58	45	48	32	44	7	6.5	45
50x5	35 _{-0.010}	90 _{-0.015}	34 _{-0.25}	25	75	59	62	45	58	4	8.8	90
50 x 10/12/16/20/25/30/40	30 _{-0.005}	80 _{-0.010}	56 _{-0.50}	47	63	50	53	40	49	11	6.5	30
63x10/20/40	40 _{-0.010}	115 _{-0.015}	46 _{-0.25}	36	94	71	80	56	70	12	8.5	30
80x10/20/40	50 _{-0.005}	140 _{-0.010}	54 _{-0.25}	45	113	88	100	63	87	12	10.5	30

1) The number of mounting holes can vary upwards

Suitable for screw ends: Form

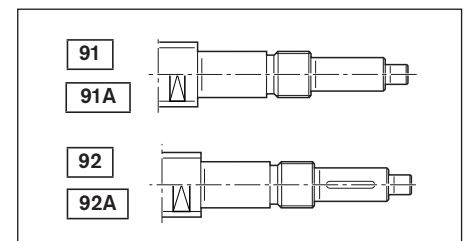
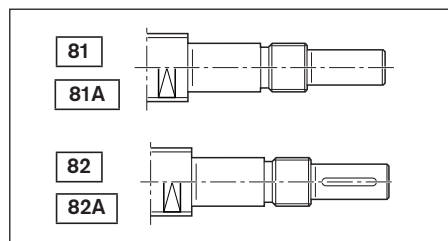
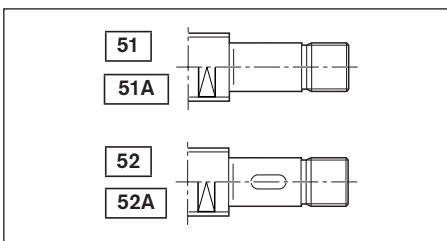

Bearing assembly LAN

Fixed bearing with angular-contact thrust ball bearing LGN

Double-thrust

Series LGN-B-...

LGN-A-...

Double-thrust, in pairs,

Series LGN-C-...

The fixed bearing consists of:

- Angular-contact thrust ball bearing LGN
- Slotted nut NMA..., NMZ...

Separate technical dimensioning to determine the limit values is absolutely necessary for all attachments (e.g. pillow block units, bearing assembly, etc.)



Size	Module	Single parts				Weight complete
		Angular-contact thrust ball bearing		Slotted nut		
$d_0 \times P$	Part number	Abbreviation	Part number	Abbreviation	Part number	(kg)
6 x 1/2	R1590 106 00	LGN-B-0624	R3414 002 06	NMZ 6x0.5	R3446 001 04	0.040
8 x 1/2/2.5/5	R1590 106 00	LGN-B-0624	R3414 002 06	NMZ 6x0.5	R3446 001 04	0.040
12 x 2/5/10	R1590 106 00	LGN-B-0624	R3414 002 06	NMZ 6x0.5	R3446 001 04	0.040
16 x 5/10/16	R1590 110 00	LGN-B-1034	R3414 003 06	NMZ 10x1	R3446 002 04	0.110
20 x 5/10/20/40	R1590 112 00	LGN-B-1242	R3414 004 06	NMZ 12x1	R3446 003 04	0.215
	R1590 117 00			LGN-B-1747	R3414 005 06	NMZ 17x1
25 x 5/10/25	R1590 117 30			NMA 17x1	R3446 014 04	0.290
	R1590 120 00	LGN-B-2052	R3414 006 06	NMZ 20x1	R3446 005 04	0.345
R1590 120 30	NMA 20x1			R3446 015 04	0.440	
40 x 5	R1590 130 00	LGN-B-3062	R3414 007 06	NMZ 30x1.5	R3446 006 04	0.465
	R1590 130 30			NMA 30x1.5	R3446 016 04	0.590
40 x 10/12/16/20/25/30/40	R1590 225 30	LGN-C-2557	R3414 014 06	NMA 25x1.5	R3446 011 04	0.840
50 x 5	R1590 135 30	LGN-B-3572	R3414 022 06	NMA 35x1.5	R3446 012 04	0.740
50 x 10/12/16/20/25/30/40	R1590 230 30	LGN-C-3062	R3414 023 06	NMA 30x1.5	R3446 016 04	0.980
63 x 10/20/40	R1590 140 30	LGN-A-4090	R3414 024 06	NMA 40x1.5	R3446 018 04	1.250
80 x 10/20/40	R1590 150 30	LGN-A-50110	R3414 025 06	NMA 50x1.5	R3446 019 04	2.930

Size	Load ratings ¹⁾		Bearing friction torque with sealing disk	Rigidity (axial)	Rigidity against tilting	Limit speed (grease)
	dyn. C (N)	stat. C ₀ (N)				
6x1/2	6,900	8,500	0.04	200	8	6,800
8x1/2/2.5/5	6,900	8,500	0.04	200	8	6,800
12x2/5/10	6,900	8,500	0.04	200	8	6,800
16x5/10/16	13,400	18,800	0.12	325	25	4,600
20x5/10/20/40	17,000	24,700	0.16	375	50	3,800
25x5/10/25	18,800	31,000	0.24	450	80	3,300
32x5/10/20/32/64	26,000	47,000	0.30	650	140	3,000
40x5	29,000	64,000	0.50	850	300	2,200
40 x 10/12/16/20/25/30/40	44,500	111,000	0.60	1,300	450	2,600
50x5	41,000	89,000	0.60	900	400	2,000
50 x 10/12/16/20/25/30/40	47,500	127,000	0.75	1,500	620	2,200
63x10/20/40	72,000	149,000	1.30	1,200	750	1,600
80x10/20/40	113,000	250,000	2.60	1,400	1,500	1,200

1) See page 187 for load on bearing

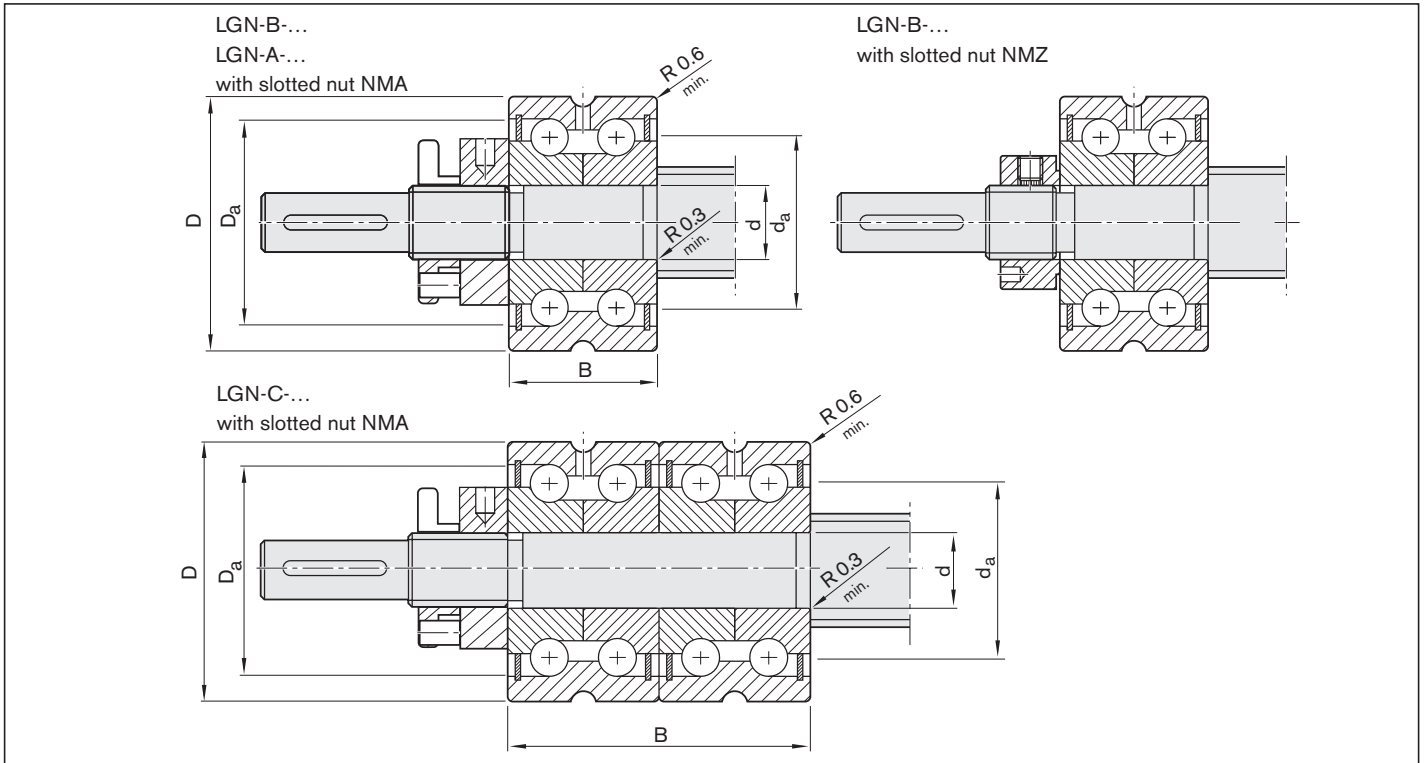

Size	(mm)			Mounting dimensions (mm)				
	d	D	B	min	D _a max	min	d _a max	
d ₀ x P								
6 x 1/2	6 ^{-0.010}	24 ^{-0.010}	15 ^{-0.25}	16	19	9	15	
8 x 1/2/2.5/5	6 ^{-0.010}	24 ^{-0.010}	15 ^{-0.25}	16	19	9	15	
12 x 2/5/10	6 ^{-0.010}	24 ^{-0.010}	15 ^{-0.25}	16	19	9	15	
16 x 5/10/16	10 ^{-0.010}	34 ^{-0.010}	20 ^{-0.25}	25	28	14	24	
20 x 5/10/20/40	12 ^{-0.010}	42 ^{-0.010}	25 ^{-0.25}	30	33	16	29	
25 x 5/10/25	17 ^{-0.010}	47 ^{-0.010}	25 ^{-0.25}	34	37	23	33	
32 x 5/10/20/32/64	20 ^{-0.010}	52 ^{-0.010}	28 ^{-0.25}	40	43	25	39	
40 x 5	30 ^{-0.010}	62 ^{-0.010}	28 ^{-0.25}	50	53	40	49	
40 x 10/12/16/20/25/30/40	25 ^{-0.005}	57 ^{-0.010}	56 ^{-0.05}	45	48	32	44	
50 x 5	35 ^{-0.010}	72 ^{-0.011}	34 ^{-0.25}	59	62	45	58	
50 x 10/12/16/20/25/30/40	30 ^{-0.005}	62 ^{-0.010}	56 ^{-0.50}	50	53	40	49	
63 x 10/20/40	40 ^{-0.005}	90 ^{-0.010}	46 ^{-0.25}	71	80	56	70	
80 x 10/20/40	50 ^{-0.005}	110 ^{-0.010}	54 ^{-0.25}	88	100	63	87	

Suitable for screw ends: Form

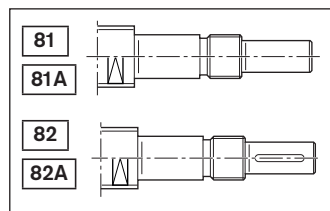
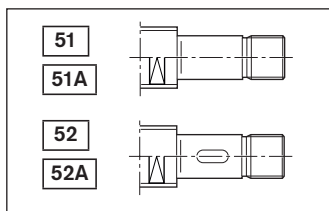

For screws 8 x 2.5: Form 831, 931
For screws 6 x 1; 6 x 2; 8 x 1; 8 x 2: Form 831

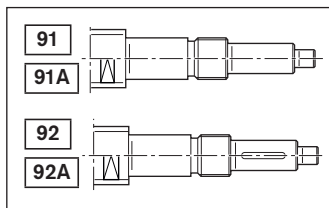
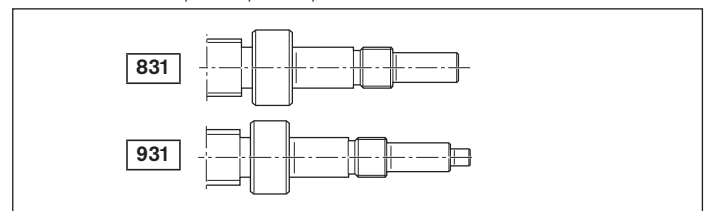

Bearing assembly LAD

Floating bearing with deep-groove ball bearing

The floating bearing system consists of:

- deep-groove ball bearing as per DIN 625... .2RS
- retaining ring DIN 471 (2 pcs)

Separate technical dimensioning to determine the limit values is absolutely necessary for all attachments (e.g. pillow block units, bearing assembly, etc.)

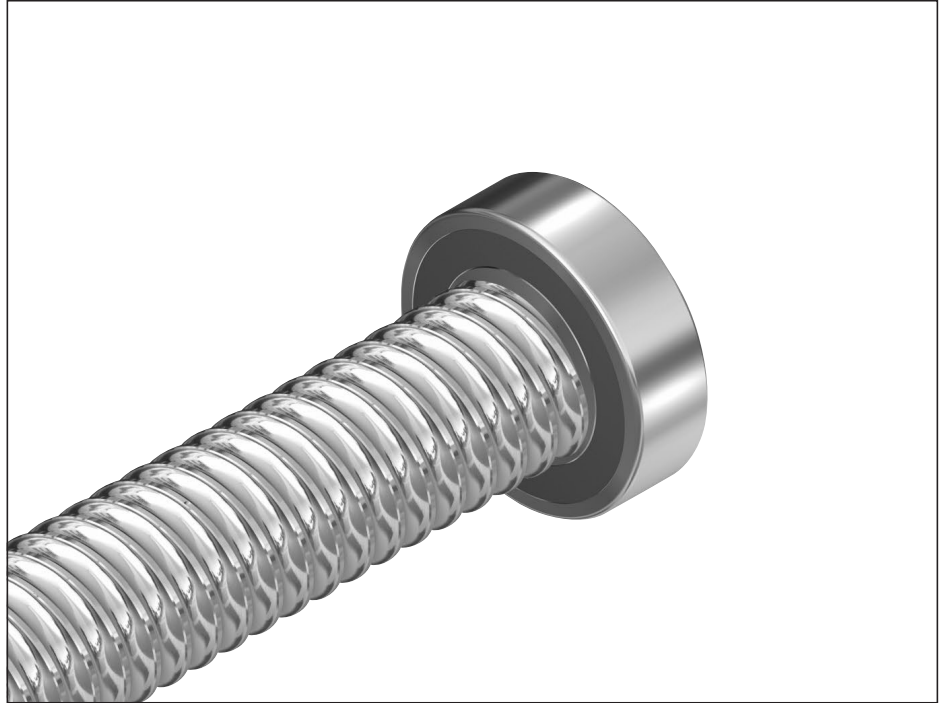

Size	Part number	Single parts				Load ratings	
		Deep-groove ball bearing DIN 625		Retaining ring DIN 471		dyn. C (N)	stat. C ₀ (N)
d ₀ x P		Abbreviation	Part number	Abbreviation	Part number		
8 x 1/2/2.5/5	R1590 605 00	625.2RS	R3414 048 00	5x0.6	R3410 742 00	1,140	380
12 x 2/5/10	R1590 606 00	626.2RS	R3414 043 00	6x0.7	R3410 736 00	2,450	900
16 x 5/10/16	R1590 610 00	6200.2RS	R3414 049 00	10x1	R3410 745 00	6,000	2,240
20 x 5/10/20/40	R1590 612 00	6201.2RS	R3414 042 00	12x1	R3410 712 00	6,950	2,650
	R1590 615 00	6202.2RS	R3414 074 00	15x1	R3410 748 00	7,800	3,250
25 x 5/10/25	R1590 617 00	6203.2RS	R3414 050 00	17x1	R3410 749 00	9,500	4,150
32 x 5/10/20/32/64	R1590 620 00	6204.2RS	R3414 038 00	20x1.2	R3410 735 00	12,700	5,700
	R1590 625 00	6205.2RS	R3414 063 00	25x1.2	R3410 750 00	14,300	6,950
40 x 5/10/12/16/20/25/30/40	R1590 630 00	6206.2RS	R3414 051 00	30x1.5	R3410 724 00	19,300	9,800
50 x 5/10/12/16/20/25/30/40	R1590 635 00	6207.2RS	R3414 075 00	35x1.5	R3410 725 00	25,500	13,200
63 x 10/20/40	R1590 650 00	6210.2RS	R3414 077 00	50x2	R3410 727 00	36,500	20,800
80 x 10/20/40	R1590 660 00	6212.2RS	R3414 078 00	60x2	R3410 764 00	52,000	31,000

Suitable for screw ends: Form

For screws 8 x 1; 8 x 2: Form 41

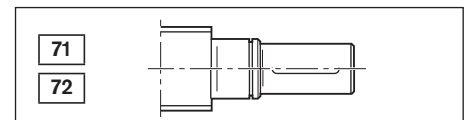
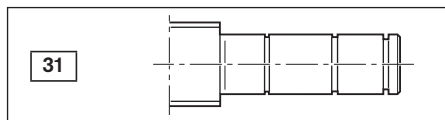
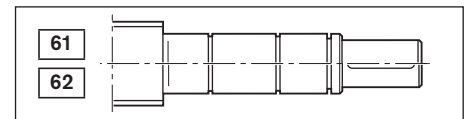
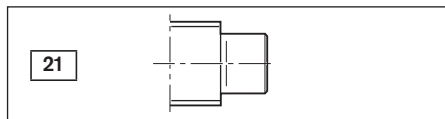
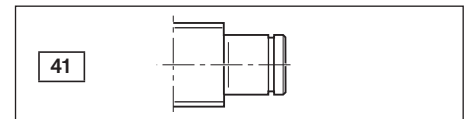
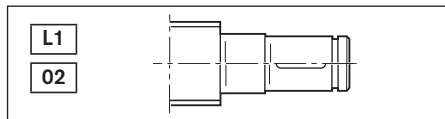

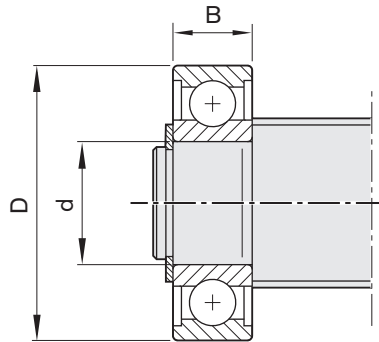

Size	(mm)			Weight complete (kg)
	d	D	B	
d₀ x P				
8 x 1/2/2.5/5	5	16	5	0.005
12 x 2/5/10	6	19	6	0.008
16 x 5/10/16	10	30	9	0.030
20 x 5/10/20/40	12	32	10	0.035
	15	35	11	0.043
25 x 5/10/25	17	40	12	0.064
32 x 5/10/20/32/64	20	47	14	0.106
	25	52	15	0.125
40 x 5/10/12/16/20/25/30/40	30	62	16	0.195
50 x 5/10/12/16/20/25/30/40	35	72	17	0.288
63 x 10/20/40	50	90	20	0.453
80 x 10/20/40	60	110	22	0.783

Bearing assembly LAL

Fixed bearing with angular-contact thrust ball bearing LGL

Double-thrust, screw-down, for inexpensive designs

The fixed bearing consists of:

- Angular-contact thrust ball bearing LGL
- Slotted nut NMG..., NMZ...

Separate technical dimensioning to determine the limit values is absolutely necessary for all attachments (e.g. pillow block units, bearing assembly, etc.)

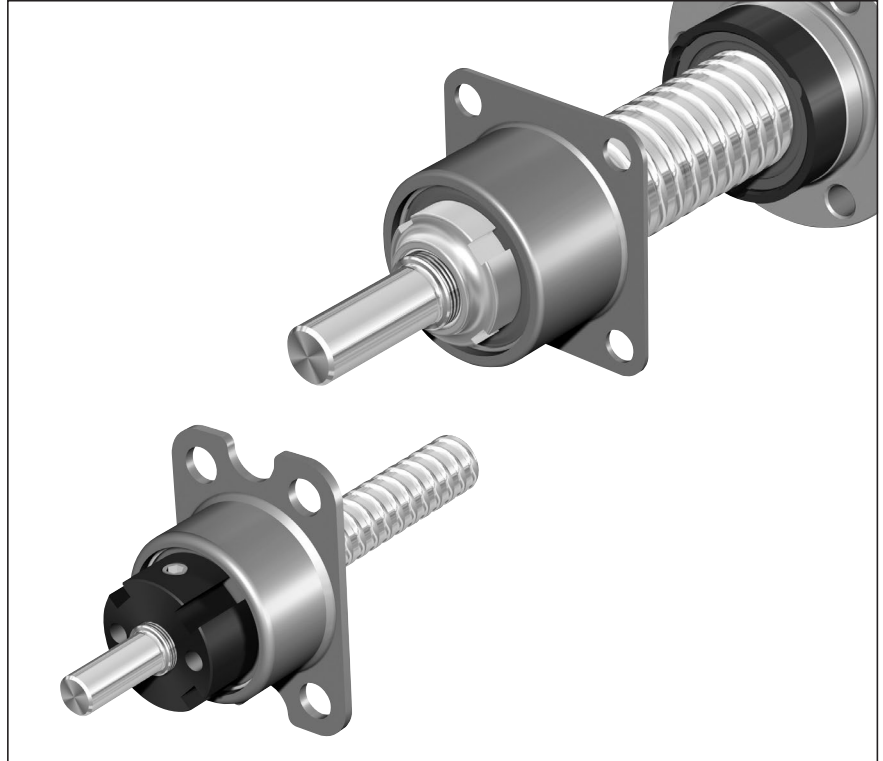

Size	Module	Single parts				Slotted nut	
		Angular-contact thrust ball bearing unit		Load ratings ¹⁾		Abbreviation	Part number
d ₀ x P	Part number	Abbreviation	Part number	dyn. C (N)	stat. C ₀ (N)		
6 x 1/2	R1590 406 00	LGL-D-0624	R3414 038 06	1,340	1,250	NMZ 6x0.5	R3446 001 04
8 x 1/2/2.5/5	R1590 406 00	LGL-D-0624	R3414 038 06	1,340	1,250	NMZ 6x0.5	R3446 001 04
12 x 2/5/10	R1590 406 00	LGL-D-0624	R3414 038 06	1,340	1,250	NMZ 6x0.5	R3446 001 04
12 x 5/10	R1590 412 00	LGL-A-1244	R3414 040 06	13,200	17,900	NMG 12x1	R3446 002 02
16 x 5/10	R1590 412 00	LGL-A-1244	R3414 040 06	13,200	17,900	NMG 12x1	R3446 002 02
20 x 5	R1590 412 00	LGL-A-1244	R3414 040 06	13,200	17,900	NMG 12x1	R3446 002 02
25 x 5/10	R1590 415 00	LGL-A-1547	R3414 041 06	16,400	22,400	NMG 15x1	R3446 011 02
32 x 5/10	R1590 420 00	LGL-A-2060	R3414 042 06	27,500	40,000	NMG 20x1	R3446 005 02

1) See page 187 for load on bearing

Suitable for screw ends: Form

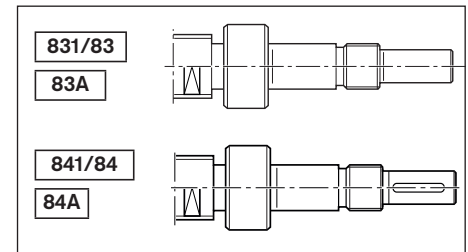
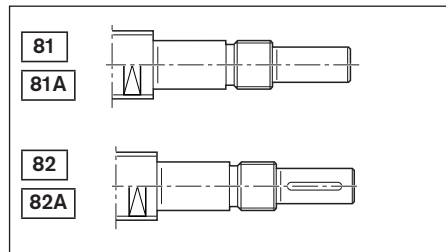

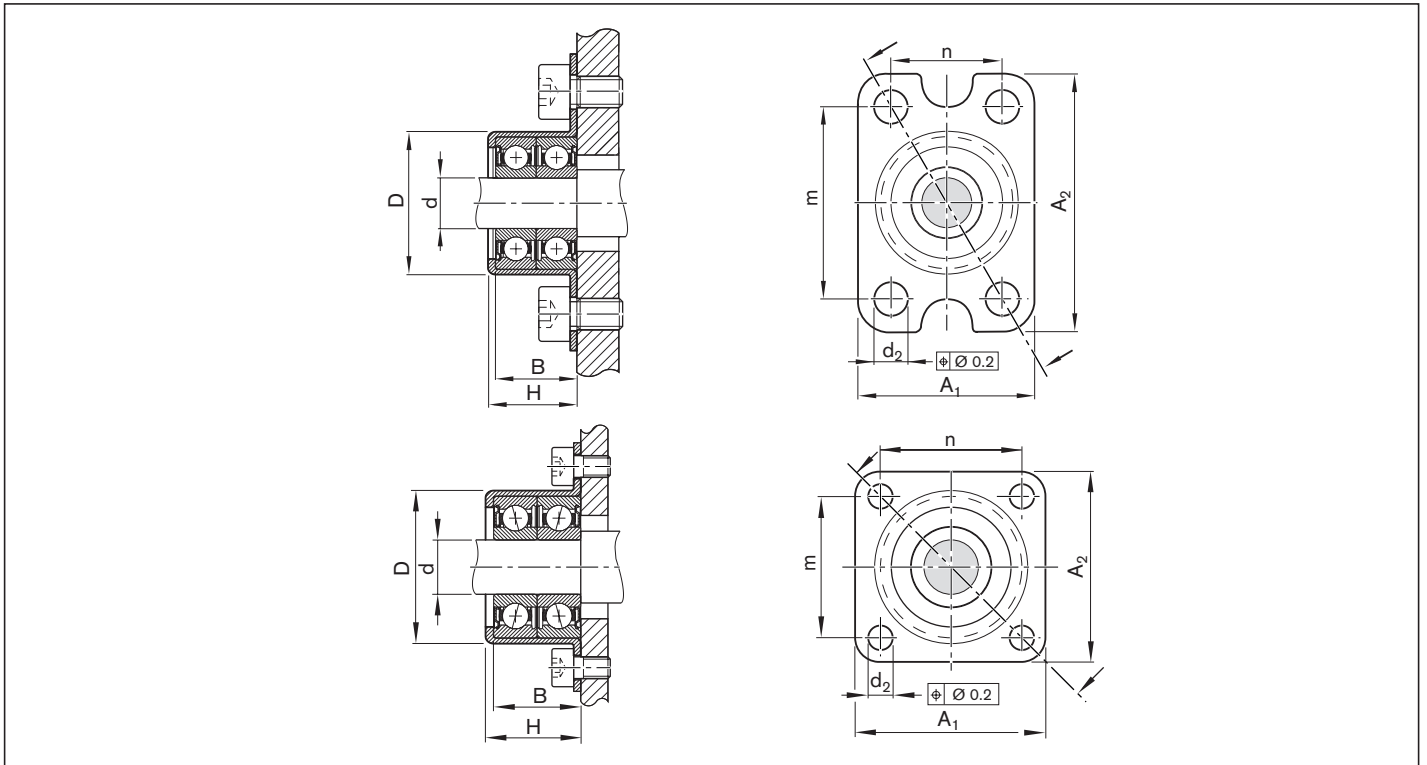

Size	(mm)										Weight of bearing (kg)
	d	D +0.03 -0.01	A_1	A_2	n	m	H -0.25	B	d_2		
$d_0 \times P$											
6 x 1/2	6	20.50	24	35	15	26	13	12	4.5	0.023	
8 x 1/2/2.5/5	6	20.50	24	35	15	26	13	12	4.5	0.023	
12 x 2/5/10	6	20.50	24	35	15	26	13	12	4.5	0.023	
12 x 5/10	12	35.45	44	50	32	38	22	20	6.6	0.120	
16 x 5/10	12	35.45	44	50	32	38	22	20	6.6	0.120	
20 x 5	12	35.45	44	50	32	38	22	20	6.6	0.120	
25 x 5/10	15	38.45	47	51	35	39	24	22	6.6	0.140	
32 x 5/10	20	50.45	60	60	47	47	30	28	6.6	0.300	

Bearing assembly LAS

Fixed bearing with angular-contact thrust ball bearing LGS

Double-thrust, series LAS-E

The fixed bearing consists of:

- Angular-contact ball bearing LGS as per DIN 628. Not available as a separate part.
- Slotted nut NMA

Separate technical dimensioning to determine the limit values is absolutely necessary for all attachments (e.g. pillow block units, assembly group bearing unit, etc.).



Size $d_0 \times P$	LAS Part number	LGS Abbreviation	Slotted nut Abbreviation	Part number	Weight complete m (kg)	C (kN)	C_0 (kN)	n_G ¹⁾ (min ⁻¹)
16 x 5/10/16	R159A 410 01	LGS-E-1030	NMZ 10x1	R3446 002 04	0.13	20	25.8	13,500
20 x 5/10/20/40	R159A 412 01	LGS-E-1232	NMZ 12x1	R3446 003 04	0.16	21.7	29.2	11,700
25 x 5/10/25 ²⁾	R159A 417 01	LGS-E-1747	NMA 17x1	R3446 014 04	0.29	27.9	31.9	8,550
32 x 5/10/20/32/64	R159A 420 01	LGS-E-2047	NMA 20x1	R3446 015 04	0.57	39.9	63.8	8,550
40 x 5/10/12/16/20/25/30/40	R159A 430 01	LGS-E-3072	NMA 30x1.5	R3446 016 04	1.68	98.3	163.1	5,850
50 x 5/10/12/16/20/25/30/40	R159A 435 01	LGS-E-3580	NMA 35x1.5	R3446 012 04	2.19	109.4	188.4	4,950
63 x 10/20/40	R159A 440 01	LGS-E-4090	NMA 40x1.5	R3446 016 08	2.74	140.8	257.7	4,500
80 x 10/20/40	R159A 450 01	LGS-E-50110	NMA 50x1.5	R3446 019 04	4.95	208.8	392.3	3,600
80 x 10/20/40	R159A 460 01	LGS-E-60130	NMA 60x2	R9130 342 16	7.49	272.5	534.6	3,015

1) Values as a guide for low bearing load, good heat dissipation and suitable lubricating greases with low consistency

2) Version 1+1

Suitable for screw ends: Form

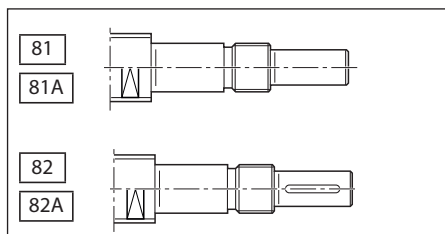

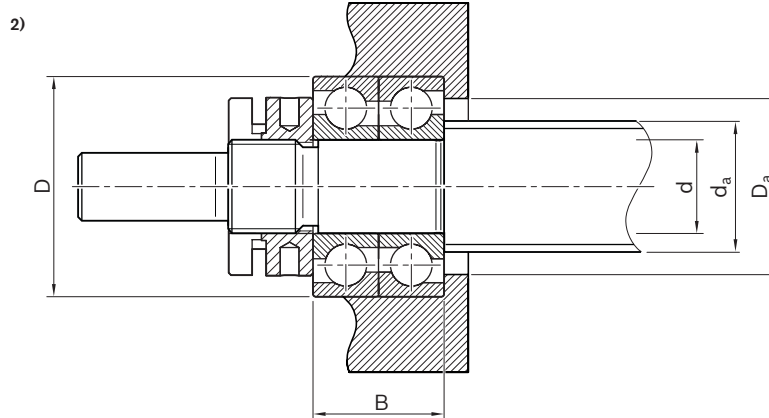
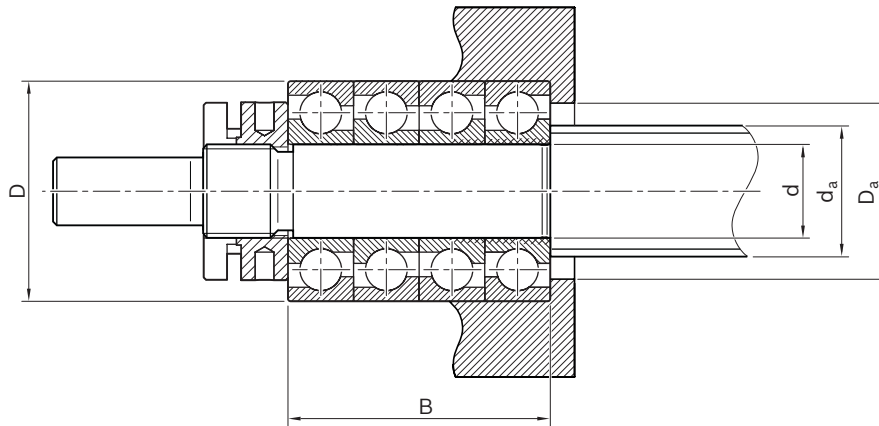

$d_0 \times P$	(mm)		B	D_a		d_a	
	d	D		min.	max.	min.	max.
16 x 5/10/16	10 _{-0.008}	30 _{-0.009}	36	22.9	25.8	14.2	22.0
20 x 5/10/20/40	12 _{-0.008}	32 _{-0.011}	40	25.0	27.8	16.2	24.0
25 x 5/10/25	17 _{-0.008}	47 _{-0.011}	28	36.2	41.4	22.6	35.0
32 x 5/10/20/32/64	20 _{-0.010}	47 _{-0.011}	56	36.0	41.0	25.6	35.0
40 x 5/10/12/16/20/25/30/40	30 _{-0.010}	72 _{-0.013}	76	56.5	65.0	37.0	55.5
50 x 5/10/12/16/20/25/30/40	35 _{-0.012}	80 _{-0.013}	84	63.0	71.0	44.0	62.0
63 x 10/20/40	40 _{-0.012}	90 _{-0.015}	92	72.0	81.0	49.0	71.0
80 x 10/20/40	50 _{-0.012}	110 _{-0.015}	108	89.0	100.0	61.0	88.0
80 x 10/20/40	60 _{-0.015}	130 _{-0.018}	124	106.0	118.0	72.0	102.0

Slotted Nuts NMA, NMZ and NMG for fixed bearings

Slotted nut NMA

- For maximum vibratory loads
- For new designs

M_A = tightening torque for slotted nut
 F_{aB} = axial breaking load of slotted nut
 M_{AG} = tightening torque for set screw

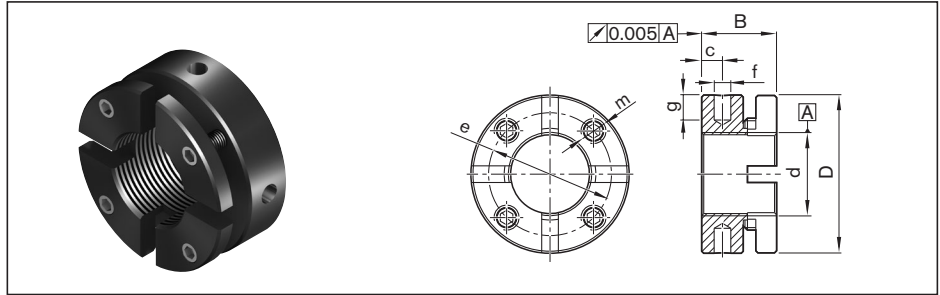

Abbreviation	Part number	(mm)								M_A	F_{aB}	M_{AG}	Mass
		d	D	B	c	m	e	f	g	(Nm)	(kN)	(Nm)	(g)
NMA 15x1	R3446 020 04	M15x1	30	18	5	M5	24	4	5	10	100	3	60
NMA 17x1	R3446 014 04	M17x1	32	18	5	M5	26	4	5	15	120	3	70
NMA 20x1	R3446 015 04	M20x1	38	18	5	M6	31	4	6	18	145	5	130
NMA 25x1.5	R3446 011 04	M25x1.5	45	20	6	M6	38	5	6	25	205	5	160
NMA 30x1.5	R3446 016 04	M30x1.5	52	20	6	M6	45	5	7	32	250	5	200
NMA 35x1.5	R3446 012 04	M35x1.5	58	20	6	M6	51	5	7	40	280	5	230
NMA 40x1.5	R3446 018 04	M40x1.5	65	22	6	M6	58	6	8	55	350	5	300
NMA 45x1.5	R9130 342 15	M45x1.5	70	22	6	M6	63	6	8	65	360	5	340
NMA 50x1.5	R3446 019 04	M50x1.5	75	25	8	M6	68	6	8	85	450	5	430
NMA 60x2	R9130 342 16	M60x2.0	90	26	8	M8	80	6	8	100	550	15	650
NMA 70x2	R9130 342 17	M70x2.0	100	28	9	M8	90	8	10	130	650	15	790
NMA 90x2	R9163 113 51	M90x2.0	130	32	13	M10	118	8	10	200	900	20	1,530

NMA 15 to NAM 40 with 4 segments
 NMA 45 to NAM 90 with 6 segments

Slotted nut NMZ

- For existing designs
- For timing belt side drive
- For driven nuts

M_A = tightening torque for slotted nut
 F_{aB} = axial breaking load of slotted nut
 M_{AG} = tightening torque for set screw

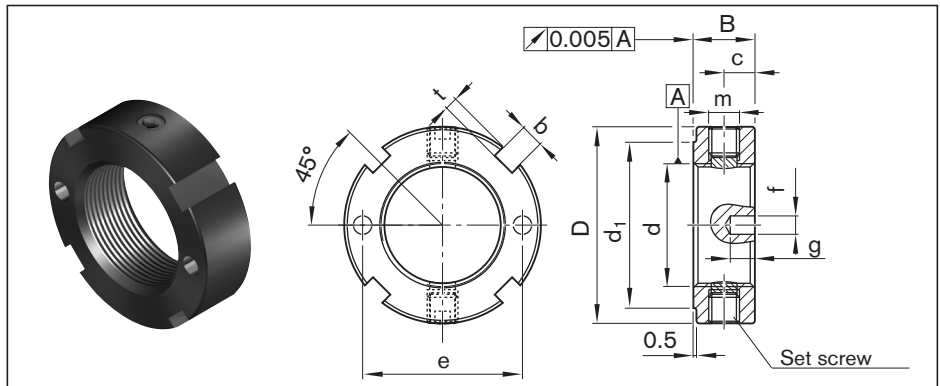

Abbreviation	Part number	(mm)											M_A	F_{aB}	M_{AG}	Mass
		d	D	B	d ₁	c	m	b	t	e	f	g	(Nm)	(kN)	(Nm)	(g)
NMZ 6x0.5	R3446 001 04	M6x0.5	16	8	12	4	M4	3	2.0	11.0	2.5	3.5	2	17	1	10
NMZ 10x1	R3446 002 04	M10x1	18	8	14	4	M4	3	2.0	14.0	2.5	3.5	6	31	1	10
NMZ 12x1	R3446 003 04	M12x1	22	8	18	4	M4	3	2.0	17.0	2.5	3.5	8	38	1	15
NMZ 17x1	R3446 004 04	M17x1	28	10	23	5	M5	4	2.0	22.5	3.0	4.0	15	57	3	28
NMA 20x1	R3446 005 04	M20x1	32	10	27	5	M5	4	2.0	26.0	3.0	4.0	18	69	3	35
NMZ 25x1.5	R3446 007 04	M25x1.5	45	20	40	10	M6	5	2.0	35.0	4.0	5.0	25	211	5	55
NMA 30x1.5	R3446 006 04	M30x1.5	45	12	40	6	M6	5	2.0	37.5	4.0	5.0	32	112	5	75
NMZ 45x1.5	R3446 032 04	M45x1.5	65	14	59	7	M6	6	2.5	-	-	-	65	181	5	170
NMZ 55x2	R3446 033 04	M55x2	75	16	68	8	M6	7	3.0	-	-	-	95	229	5	230
NMZ 60x2	R3446 031 04	M60x2	80	16	73	8	M6	7	3.0	-	-	-	100	255	5	250
NMZ 70x2	R3446 034 04	M70x2	92	18	85	9	M8	8	3.5	-	-	-	130	305	15	360
NMZ 80x2	R3446 035 04	M80x2	105	18	95	9	M8	8	3.5	-	-	-	160	355	15	460
NMZ 90x2	R3446 036 04	M90x2	120	20	108	10	M8	10	4.0	-	-	-	200	410	15	700

Assembly tool for slotted nut

General-purpose socket wrench insert for slotted nuts NMA / NMZ
– Available on request

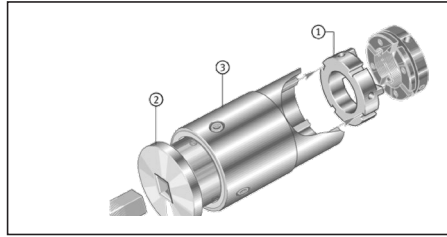

NMA: consisting of components: AMS, ZMS and ZME

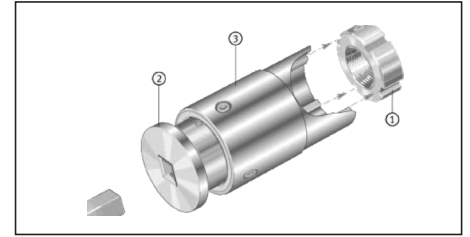

NMZ: consisting of components: ZMS and ZME

Slotted nut NMG

– For inexpensive designs

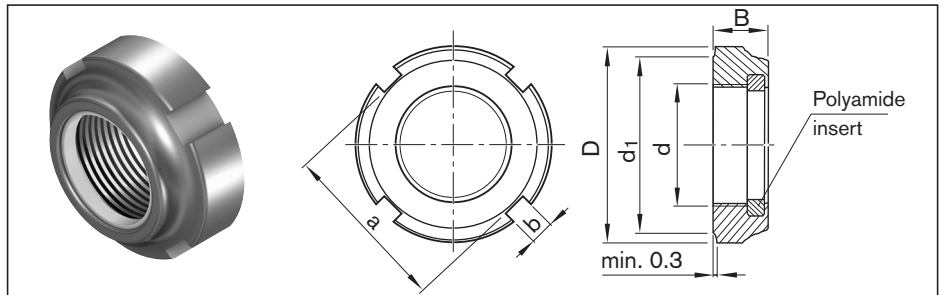

Abbreviation	Part number	Dimensions (mm)						M_A (Nm)	Mass (g)
		d	D	B	d_1	a	b		
NMG 12x1	R3446 002 02	M12x1	21	7.6	18	18	3	8	10
NMG 15x1	R3446 011 02	M15x1	24	8.6	21	21	4	10	13
NMG 20x1	R3446 005 02	M20x1	32	9.6	27	27	4	18	24

M_A = tightening torque for slotted nut

Ring nut GWR

– For angular-contact thrust ball bearing LGN
– For cylindrical single nut ZEM-E-S

Attention:
Use a threadlocker (for example, Loctite 638) to secure against loosening

M_A = tightening torque for housing nut

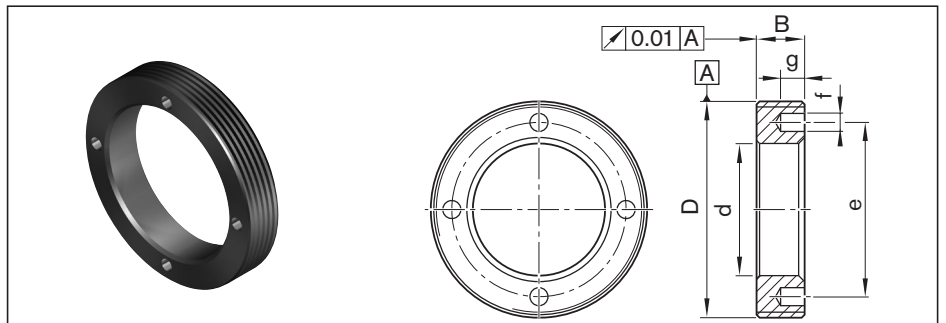

Abbreviation	Part number	Dimensions (mm)							M_A (Nm)	Mass (g)
		D	d	B	e	f	g			
GWR 18x1	R1507 040 33	M18x1	8.5	8	12.5	2.5	3	6	10.0	
GWR 23x1	R1507 240 35	M23x1	13.0	8	18.0	2.5	3	8	15.0	
GWR 26x1.5	R1507 240 22	M26x1.5	16.5	8	20.5	2.5	3	10	16.5	
GWR 30x1.5	R1507 340 34	M30x1.5	17.0	8	23.0	3.0	4	20	29.0	
GWR 36x1.5	R1507 040 23	M36x1.5	22.0	8	29.0	3.0	4	25	35.0	
GWR 40x1.5	R1507 140 03	M40x1.5	25.0	8	33.0	3.0	4	28	39.5	
GWR 45x1.5	R1507 240 04	M45x1.5	28.0	8	38.0	3.0	4	30	55.0	
GWR 50x1.5	R1507 240 25	M50x1.5	31.0	10	40.0	4.0	5	45	86.0	
GWR 55x1.5	R1507 340 05	M55x1.5	36.0	10	46.0	4.0	5	50	96.0	
GWR 58x1.5	R1507 440 32	M58x1.5	43.0	10	50.0	4.0	5	58	84.0	
GWR 60x1	R1507 440 28	M60x1	43.0	10	51.0	4.0	5	60	97.0	
GWR 62x1.5	R1507 440 29	M62x1.5	43.0	12	53.0	5.0	6	60	127.0	
GWR 65x1.5	R1507 440 26	M65x1.5	47.0	12	55.0	4.0	5	70	136.0	
GWR 70x1.5	R1507 440 06	M70x1.5	42.0	12	58.0	4.0	5	75	216.0	
GWR 78x2	R1507 567 27	M78x2	54.0	15	67.0	6.0	7	90	286.0	
GWR 92x2	R1507 640 09	M92x2	65.0	16	82.0	6.0	7	125	385.0	
GWR 95x2	R1507 667 28	M95x2	68.0	16	82.0	6.0	7	130	425.0	
GWR 112x2	R1507 740 11	M112x2	82.0	18	100.0	8.0	8	175	596.0	
GWR 115x2	R1507 767 29	M115x2	85.0	18	100.0	8.0	8	200	664.0	

Ball screw assembly with front lube unit

Characteristic features

Equipped with Rexroth's functionally reliable, series-made front lube unit, a ball screw assembly can attain an exceptionally long travel life without relubrication. Thanks to intensive development work and thorough testing under realistic conditions, the use of front lube units combined with prelubricated nuts enables you to achieve lifelong, optimal lubrication of Rexroth precision ball screw assemblies.

From its built-in oil reservoir, the front lube unit delivers the precise amount of oil required to replenish the used amounts of oil in the soap matrix of the grease. The oil is applied directly to the raceway of the ball screws via the low-friction point-contact zone of the open-pored foam. This optimized delivery minimizes lubricant consumption and allows you to achieve lifelong lubrication.

Ecologically sound

The front lube unit ideally combines eco-friendliness with cost-efficiency. It minimizes oil consumption and keeps the surroundings clean. This helps to conserve resources.

Further highlights

- Delivered with the ball screw assembly ready-mounted.
- Attaches to one side of the nut, thus saving space.
- Can be used in all mounting positions, both in horizontal and vertical installations.
- Available for almost all nut types with diameters 20 to 40
- Easy to integrate in constructions by attaching it either on the flange side or on the opposite side of the single-start nuts.
- When attached to both sides, it also meets the lubrication needs of high-capacity two-start nuts (FED-E-B).
- Can be used in all normal ambient conditions, except in wet or dusty environments.



Lubrication concept

This logo indicates that the Rexroth ball screw assembly with prelubed nut and front lube unit are lubed for life.

Note: The front lube unit is not suitable for use with driven nuts.

Lifelong lubrication

The effective life of the Rexroth front lube unit matches the service life curve of the Ball Screw Assembly. When operated within the recommended load limits, a ball screw assembly equipped with a Front Lube Unit will require no relubrication, thanks to the optimal delivery of lubricant. Based on our extensive tests, the lubrication performance of the front lube unit can now be reliably predicted for the first time. With a Front Lube Unit from Rexroth, a ball screw assembly can run trouble-free for **five years** or **300 million revolutions** without any relubrication.

Structural design of front lube units

- 1 Seal
- 2 Housing and cover
 - Material: special plastic
- 3 Open-pored foam
- 4 Housing nut
- 5 Intermediate ring
- 6 Recirculation cap
- 7 Ball nut
- 8 Ball screw

Notes

When selecting the size for the stroke, consider the dimensions of the VSE.
When setting up a system, do not allow the VSE to collide with a stop or other components.

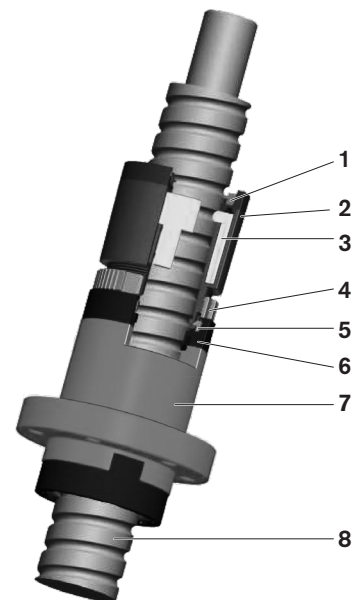

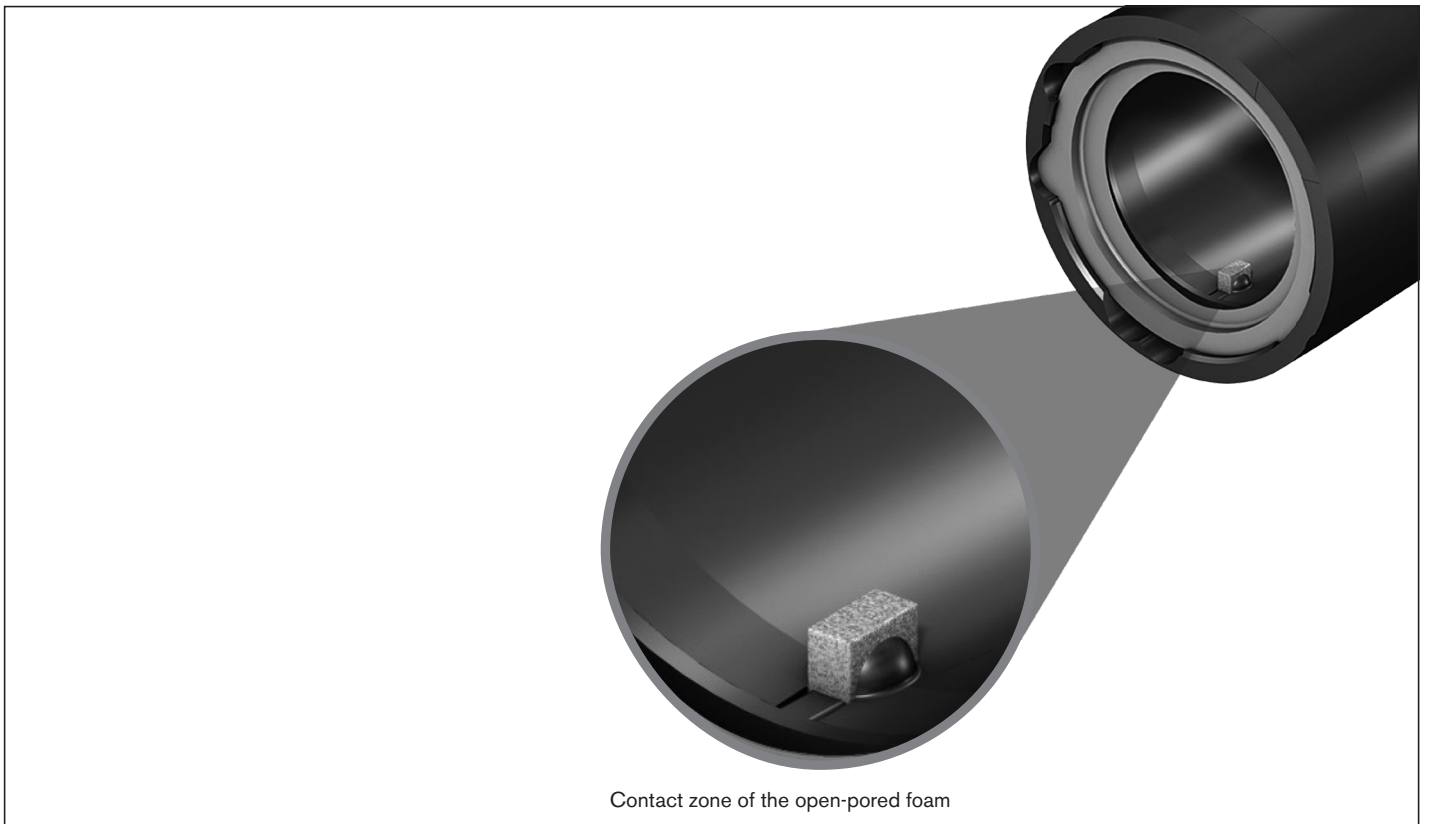

Contact zone of the open-pored foam

Ball nut with front lube unit

Front lube unit

The front lube unit (VSE) has been designed for the long-term, maintenance-free operation of the ball screw assembly. It is attached to the nut and delivers lube oil continuously to the rolling elements.

For travel up to 300 million revolutions without relubrication.

The front lube unit can be combined with the following nut types:

- FEM-E-S
- FEM-E-B
- SEM-E-S
- SEM-E-C
- FED-E-B
- FDM-E-S
- FDM-E-B

Lifelong lubrication

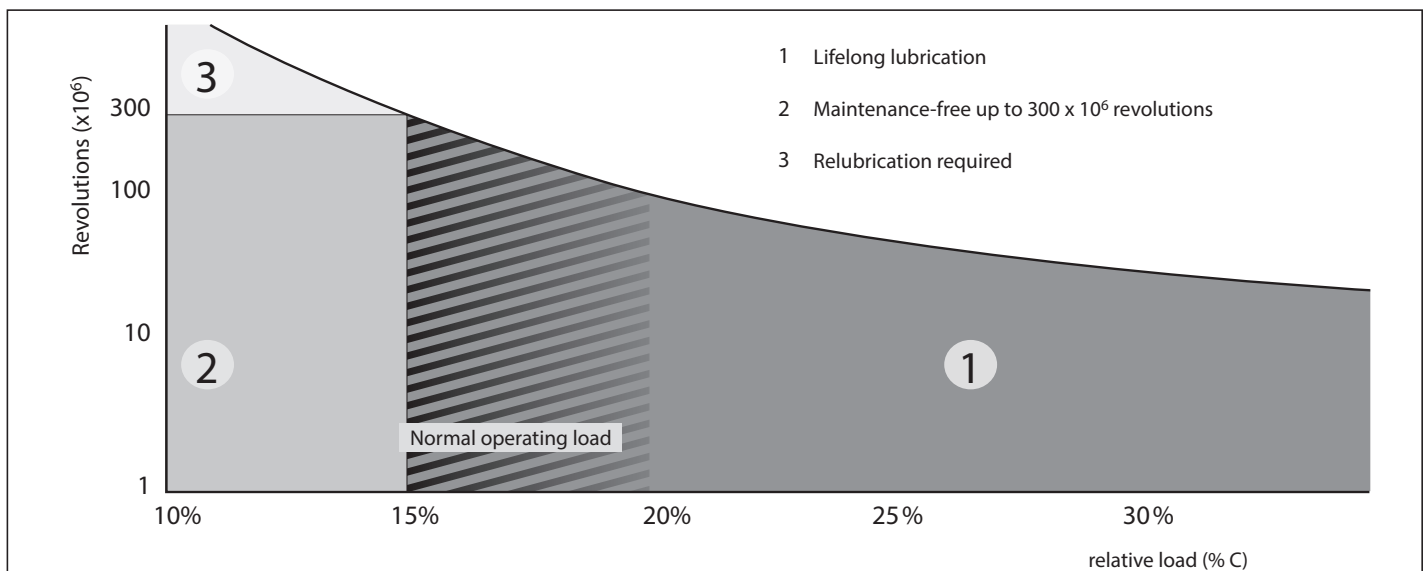

Results confirmed by our extensive tests:

- 1 For axial loads of 15-35% of the dynamic load rating C, the ball nut will be lubed for life.
- 2 For axial loads of < 15% of the dynamic load rating C, the ball screw assembly will require no maintenance for up to 300 million revolutions.
- 3 After 300 million revolutions, the ball nut should be relubricated as usual. The front lube unit does not have to be removed from the nut.

Lead (mm)	Travel s with front lube units ¹⁾ (km)
5	1,500
10	3,000
20	6,000
25	7,500
32	9,600
40	12,000

1) max. load up to 0.15C

Technical data

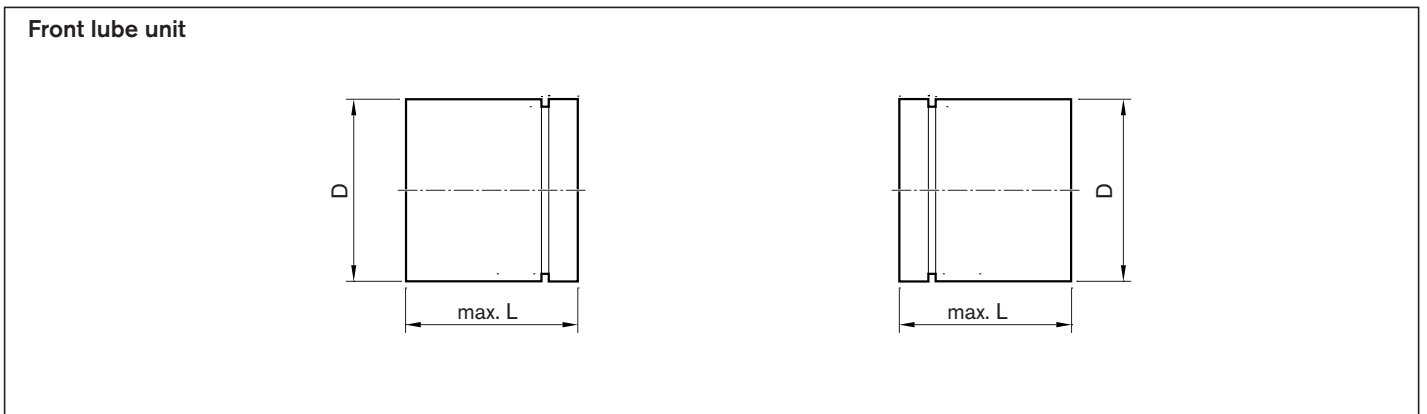
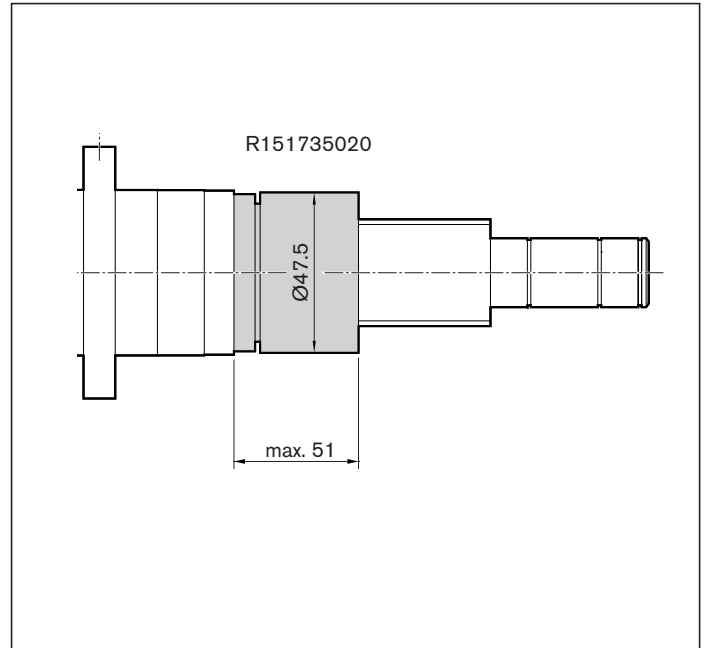
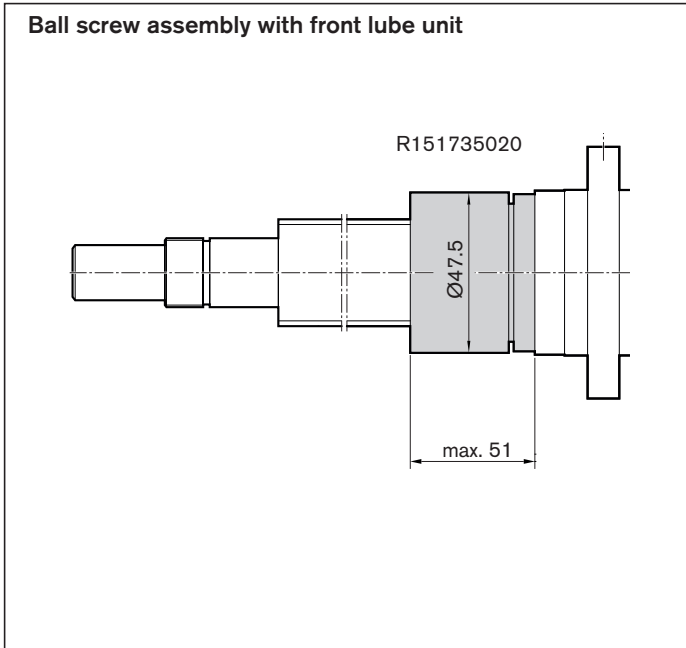

Note: The front lube unit is delivered ready-mounted to the ball screw assembly. Only installation by the manufacturer is permitted.

Size of VSE d ₀ x P	Part number	(mm)		Weight (kg)	
		D	L	m	
20 x 5 R	R151715000	32.60	51.00	0.021	
20 x 20 R					
25 x 5 R	R151725010	37.50	51.00	0.027	
25 x 10 R					
25 x 25 R					
32 x 5 R	R151735030	47.50	51.00	0.042	
32 x 10 R					
32 x 20 R					
32 x 32 R					
40 x 5 R	R151745030	55.50	53.00	0.055	
40 x 10 R	R151745050	62.30	51.00	0.070	
40 x 20 R					
40 x 40 R					

Ball nut with front lube unit

Ordering example for front lube unit with illustration of mounting orientation

BASA 32 x 10R x 3,969 **FEM-E-S - 5** 00 1 3 T7 R 81K203 31K200 1000 0 2

Front lube unit on left, nut with initial greasing

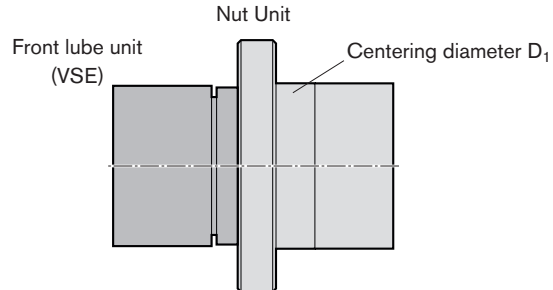

BASA 32 x 10R x 3,969 **FEM-E-S - 5** 00 1 3 T7 R 81K203 31K200 1000 0 3

Front lube unit on right, nut with initial greasing

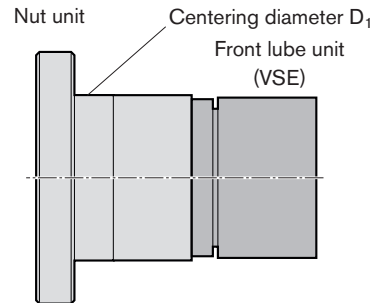

BASA 40 x 20R x 6 **FED-E-B - 8** 00 1 3 T7 R 81K250 31K300 1000 0 4

Front lube unit on two sides, nut with initial greasing

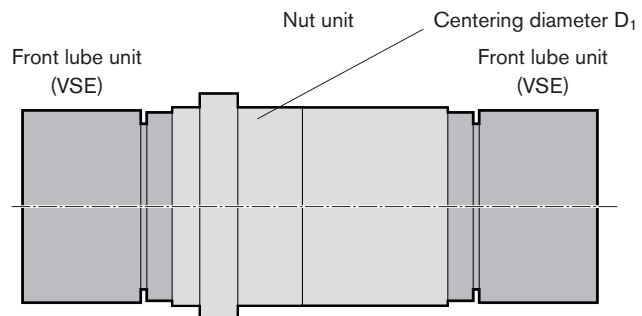

Mounting orientation of the front lube unit on nut types

Nut type	Mounting orientation
FEM-E-S	2, 3
FEM-E-B	2, 3
SEM-E-S	2, 3
SEM-E-C	2, 3
FED-E-B	4
FDM-E-S	2, 3
FDM-E-B	2, 3

Measuring pads

Alignment of the ball screw assembly in the machine

A gauge with a self-aligning contact pad is available from Rexroth for easy alignment of the ball screw assembly.

Two pads of different lengths are available which can be used depending on the screw lead:

- Part number R3305 131 19, length 33 mm for leads < 20
- Part number R3305 131 21, length 50 mm for leads > 20

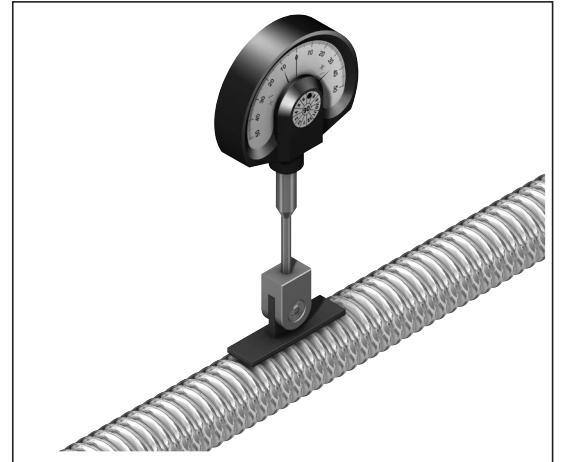

Dial gauge not supplied as standard with the ball screw assembly

Arrestor nut

Assembly/set-up/ features

- Installation on flange with hexagon socket screws for fixing the arrestor nut
- Centering diameter prevents radial displacement
- Wiper seal is not mounted on the nut, but on the arrestor nut. (This keeps dirt out of the space between the arrestor nut and the screw)
- Length of the safety nut determines the safety factor (Standard: 2-fold safety as against the static load capacity)
- Multiple-thread arrestor nuts are used for multiple-thread screws

Recommended installation

The force or mass must always lie on the arrestor nut so that there is no tensile loading of the fastening screws.

The fixed bearing of the screw should be located at the bottom. Inspection may only be carried out by trained service engineers.

Design

Please consult our staff

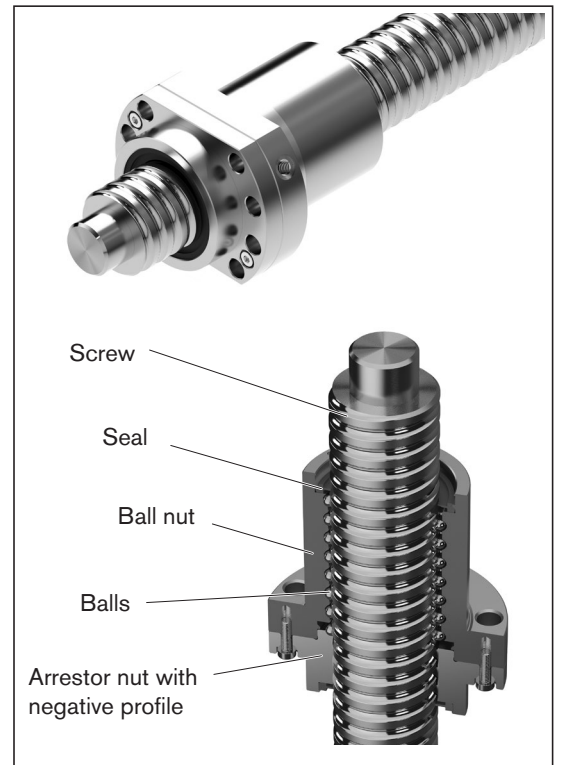

Mode of operation

The ball nut with arrestor nut comprises the ball nut (for example, FEM-E-B) and an additional arrestor nut whose negative profile locks into the screw raceway. The ball nut with arrestor nut basically works in the same way as a normal ball nut. If the ball nut fails to work (for example, owing to a loss of balls), the arrestor nut thread comes into contact with the screw. This prevents an uncontrolled dropping of the nut.

Use

In critical applications in non-horizontal operation (for example, in order to prevent damage to property). The arrestor nut is fitted to the nut from below in the direction of force.

Arrestor nuts are not safety components within the meaning of the European Machinery Directive 2006/42/EC. Responsibility for the safety of the structural design / specific application therefore still lies with you and the manufacturer. Particular attention must be paid to ensuring that there are no hazards to people. Therefore, in particular in the case of vertically loaded axes, the structure must incorporate an additional safety catch/holding device which prevents a drive component failure! The falling of the nut must be prevented in all cases.

Technical notes

ISO 3408-1 defines a ball screw assembly as follows:

A ball screw drive (BASA) is a unit consisting of a ball screw shaft, ball nut, and balls that is able to convert rotary motion into linear motion, and vice versa.

Advantages over the acme screw drive

- The maximum mechanical efficiency of an Acme screw drive is 50%, whereas a planetary screw assembly can achieve 90%, and a ball screw assembly 98%.
- Higher life expectancy due to negligible wear during operation
- Less drive power required
- No stick-slip effect
- More precise positioning
- Higher travel speed
- Less heat-up

Due to the high level of effectivity (low friction level between the screw and the nut), ball screw drives are not self-locking.

⚠ Safety information

If installing in a non-horizontal position, customers should check whether separate protection against falling loads is necessary, e.g. an arrestor nut. With particularly critical applications in vertical operation, we recommend installing arrestor nuts. Please consult us.

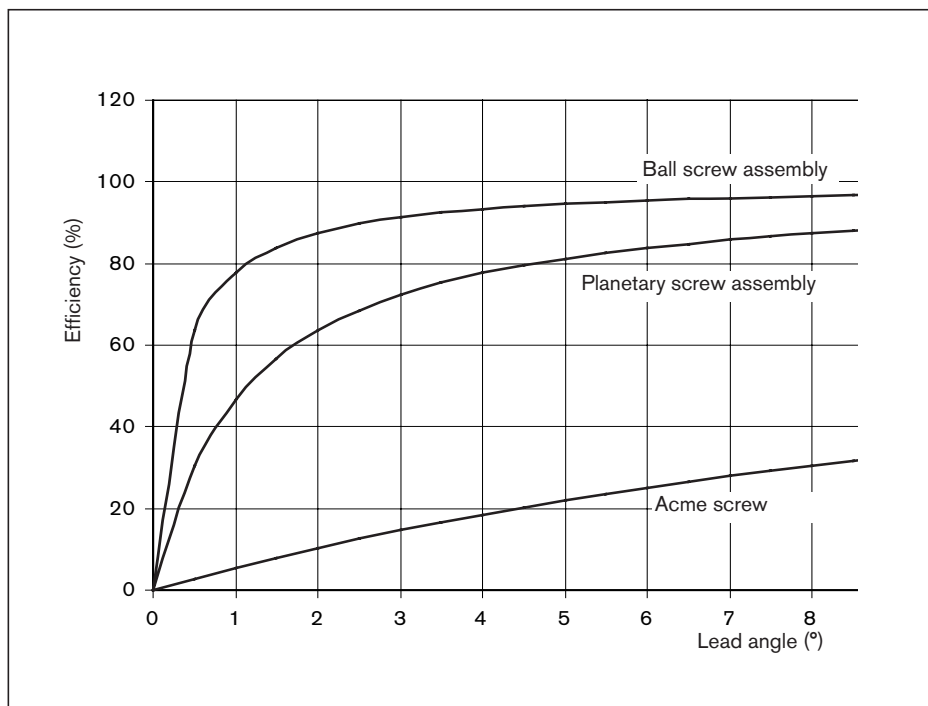

Selection criteria for ball screw drives

The factors below are significant when rating a ball screw drive:

- Degree of accuracy required (lead deviation)
- Load
- Service life
- critical speed
- buckling load
- rigidity/permissible clearance or desired preload
- characteristic speed (max. permissible linear speed)

The following points should be taken into consideration when selecting a PLSA that is to be both cost-efficient and optimally designed:

- The lead is a crucial factor in the load-bearing capacity (conditional on the maximum possible ball diameter) and the drive torque.
- The calculation of the service life should be based on average loads and average speeds, not on maximum values.
- In order for us to provide you with a customized solution, installation drawings or sketches of the nut environment should be enclosed.

⚠ Note

Radial and eccentric forces relative to the screw must be avoided, as they can negatively affect the ball screw drive's performance and shorten its service life.

Where special conditions of use are involved, please consult us.

Load ratings and service life

The calculations for the load capacities and service lives are based on ISO 3408-5. The dynamic load capacities in the tables are above the ISO 3408-5 values. These values have been confirmed in tests.

Static load rating C₀

The static load rating is an axial, concentrically acting force that induces a permanent deformation of 0.0001 x the ball diameter between the ball and the ball track.

Dynamic load rating C

The dynamic load rating is an axial, concentrically acting force of constant magnitude and direction under which 90% of a sufficiently large number of identical BASAs can achieve a nominal service life of one million revolutions.

Correction factor for tolerance grades

The static load rating C₀ and the dynamic load rating C must be multiplied by the correction factor f_{ac} as appropriate for the specific tolerance grade of the screw.

Tolerance grade T	3	5	7	9
f _{ac}	1	1	0,9	0,8

Service life

The nominal service life is expressed by the number of revolutions (or number of operating hours at constant speed) that will be attained or exceeded by 90% of a representative sample of identical BASAs before the first signs of material fatigue become evident. The nominal life is designated as L or L_h h, depending on whether it is specified in revolutions or hours.

Short stroke

Short stroke applications = stroke ≤ nut length

Lubrication:

During a short stroke, the planets do not make a real turn. It is therefore impossible for an adequate lubricating film to form. This may result in premature wear.

To avoid this, it is sufficient to perform longer strokes at regular intervals with simultaneous relubrication as "lubricating strokes".

Please consult our regional centers regarding short stroke applications.

You can find your local contact person at: www.boschrexroth.com/contact

Load rating:

Short stroke applications will increase the number of times a rolling load passes over each point within the load zone. This reduces the load rating.

Critical speed and buckling load

The critical speed and buckling load can be checked using the corresponding charts. For precise calculations see formula 12 15 , in the section "Design Calculations3."

Characteristic speed d₀ · n

Due to their structural design, Rexroth ball screw assemblies can be operated at very high speeds. Characteristic speeds of up to 150,000 are possible depending on the nut type.

$$d_0 \cdot n \leq 150,000$$

d₀ = nominal diameter (mm)
 n = speed (rpm)

The theoretically possible maximum linear speed v_{max} (m/min) is specified on the page featuring the relevant nut. Actually attainable speeds are heavily dependent among other factors on preload and duty cycle.

They are generally restricted by the critical speed. (See "Design Calculations").

Material, hardness

BASAs are made of high-quality, heat-treatable steel, carbon chrome alloy steels or case-hardened steels. The screw and nut raceways have a minimum Rockwell hardness of HRC 58.

Ball screw drives made from stainless steel (DIN EN 10088) are available on request.

Normally, the screw ends are not hardened.

Vertical axes

For vertical application of ball screw assemblies, we recommend a maximum medium preload. Information on protection against falling loads can be found under "Arrestor nut."

Sealing

Ball screw drives need protection from contamination. Flat protective covers, bellows-type dust boots, or the AGK drive unit are particularly suitable for this. Since there are many applications in which these methods do not provide sufficient protection, we have developed a gapless lip-type seal which ensures an optimal sealing effect and maintains high efficiency due to the low friction level. This means that the standard versions of our ball screw drives are supplied with seals. At the customer's request, the seals can be omitted entirely or special seals are used. For applications where it appears that it is not possible to avoid severe contamination of the screw, we have developed a reinforced variant of the standard seal. The sealing effect has been enhanced even further by increasing the preload. You should note the considerably higher frictional torque (see the technical data) compared to standard seals which leads to greater heat generation. You can easily recognize the reinforced seal by its dark-green color.

Permissible operating temperatures

Ball screw drives permit operation at continuous temperatures of up to 80 °C with temporary peaks of 100 °C (measurements taken on the outer shell of the nut in each case).

Permissible operating temperatures:

$$-10 \text{ °C} \leq T_{\text{operation}} \leq 80 \text{ °C}$$

Permissible storage temperature

$$-15 \text{ °C} \leq T_{\text{bearing}} \leq 80 \text{ °C}$$

Bearing

When calculating the life expectancy of the overall system, the end bearings must be considered separately.

Acceptance Conditions and Tolerance Grades

Permissible travel deviation

According to ISO 3408-3

Symbol definitions:

(excerpt)

- l_0 = nominal travel
- l_1 = thread length
- Δl_0 = travel deviation
- l_u = Useful travel
- l_e = excess travel (the closer tolerances for travel and hardness do not apply here)
- c = travel compensation (target travel deviation) (standard: $c = 0$)
- e_p = tolerance mean target travel deviation
- v_{300p} = permissible travel deviation within 300 mm travel
- a = actual
- p = permissible

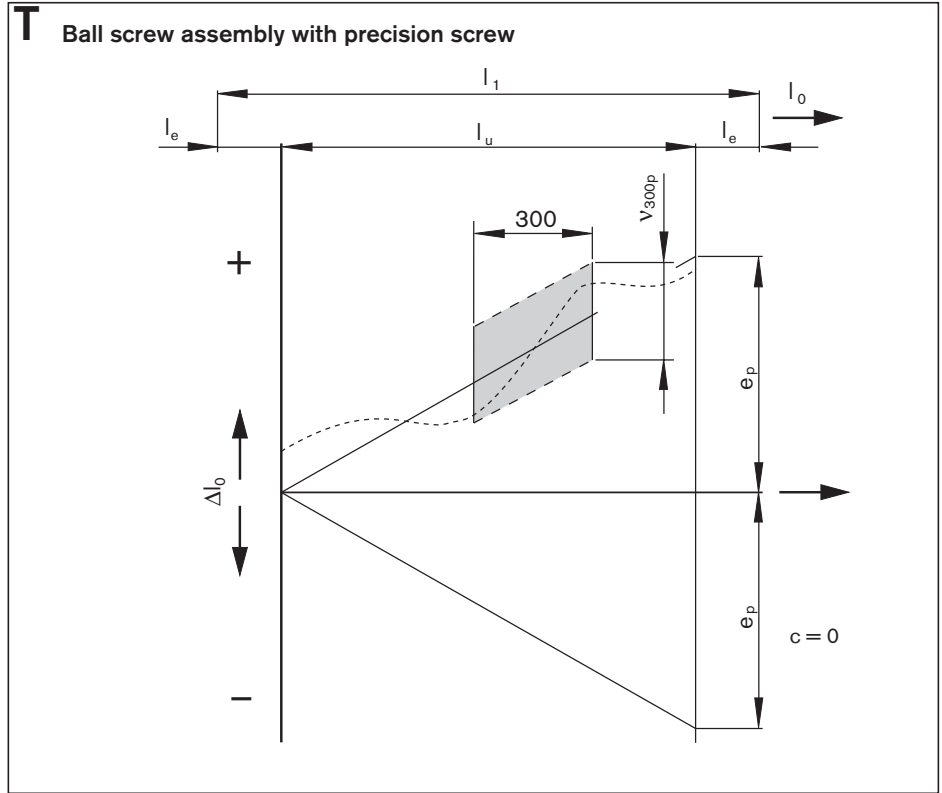

Tolerance grades of precision screws

Tolerance grade			
3	5	7	9

Permissible travel deviation within 300 mm travel

v_{300p} (μm)			
Tolerance grade			
3	5	7	9
12	23	52	130

Permissible target travel deviation

Useful travel l_u		Tolerance for target travel e_p (μm)			
		Tolerance grade			
>	\leq	3	5	7	9
0	100	8	18	44	110
100	200	10	20	48	120
200	315	12	23	52	130
315		$e_p = \frac{l_u}{300} \cdot v_{300p}$			

Non-usable length l_e

(Excess travel)

Modified compared to ISO 3408-3

d_0 (mm)	l_e (mm)
6, 8	15
12, 16	20
20, 25, 32, 40	40
50, 63, 80	50

Minimum number of measurements within 300 mm (measuring interval) and excess travel to be taken into consideration.

Lead P (mm)	Minimum number of measurements for tolerance grade			
	3	5	7	9
1	10	6	3	2
2	10	6	3	2
2.5	10	6	3	2
5	10	6	3	2
10	5	3	1	1
12	5	3	1	1
16	5	3	1	1
20	4	3	1	1
25	4	3	1	1
30	3	2	1	1
32	3	2	1	1
40	2	1	1	1
64	2	1	1	1

Acceptance conditions and tolerance grades

Run-outs and location deviations

Based on DIN ISO 3408-3

Radial run-out t_5 of the outer diameter of the screw over the length l_5 used to determine the straightness relative to AA'.

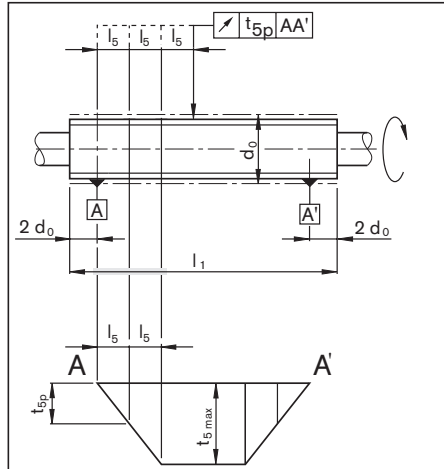

d_0		l_5	t_{5p} in μm for l_5 for tolerance grade			
Over	Up to		3	5	7	9
= 6	12	80	25	32	40	60
12	25	160				
25	50	315				
50	100	630				

l_1/d_0		t_{5max} in μm for $l_1 \geq 4 l_5$ Tolerance grade			
Over	Up to	3	5	7	9
	40	50	64	80	120
40	60	75	96	120	180
60	80	125	160	200	300
80	100	200	256	320	480

Coaxial deviation t_6 of the bearing journal in relation to AA' where $l_6 \leq l$.
 Table value t_{6p} applies if $l_6 \leq$ reference length l .

Where $l_6 > l$, then
$$t_{6a} \leq t_{6p} \cdot \frac{l_{6a}}{l}$$

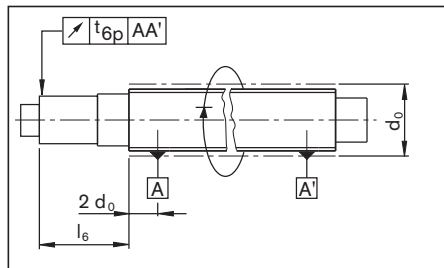

Nominal diameter d_0		Reference length l	t_{6p} in μm for $l_6 \leq l$ Tolerance grade			
Over	Up to		3	5	7	9
= 6	20	80	12	20	40	50
20	50	125	16	25	50	63
50	125	200	20	32	63	80

Radial run-out t_7 of the journal diameter of the ball screw shaft relative to the bearing diameter for $l_7 \leq l$.
 Table value t_{7p} applies if $l_7 \leq$ reference length l .

Where $l_7 > l$, then
$$t_{7a} \leq t_{7p} \cdot \frac{l_{7a}}{l}$$

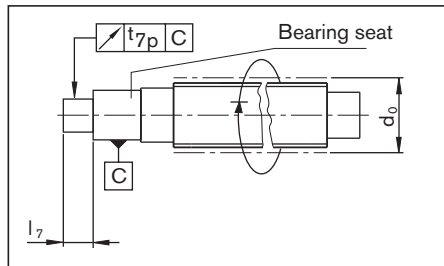

Nominal diameter d_0		Reference length l	t_{7p} in μm for $l_7 \leq l$ Tolerance grade			
Over	Up to		3	5	7	9
= 6	20	80	6	8	12	14
20	50	125	8	10	16	18
50	125	200	10	12	20	23

Axial run-out t_8 of the shaft (bearing) face of the ball screw shaft relative to the bearing diameter.

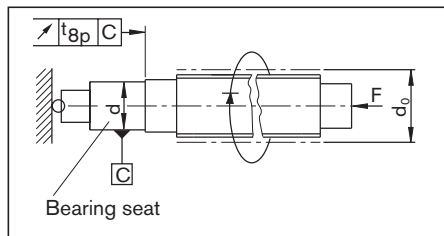

Nominal diameter d_0		t_{8p} in μm for tolerance grade			
Over	Up to	3	5	7	9
= 6	63	4	5	6	8
63	125	5	6	8	10

Axial run-out t_9 of the ball nut location face in relation to A and A' (for preloaded ball nuts only).

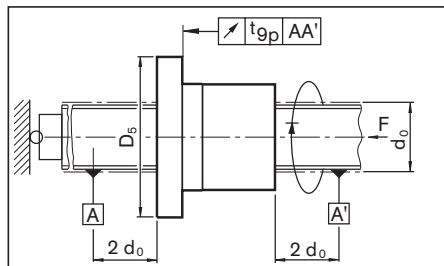

Flange diameter D_5		t_{9p} in μm for tolerance grade			
Over	Up to	3	5	7	9
16	32	12	16	20	-
32	63	16	20	25	-
63	125	20	25	32	-
125	250	25	32	40	-

Radial run-out t_{10} of the outer diameter D_1 of the ball nut relative to **A** and **A'** (for preloaded and rotating ball nuts only). When measuring, fix the ball screw shaft to prevent rotation.

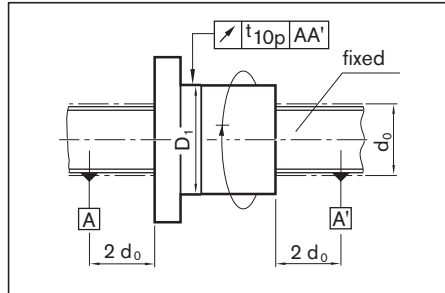

Outer diameter D_1		t_{10p} in μm for tolerance grade			
Over	Up to	3	5	7	9
16	32	12	16	20	-
32	63	16	20	25	-
63	125	20	25	32	-
125	250	25	32	40	-

Please contact us for the permissible axial and radial run-out with a driven nut

Limiting deviation ΔT_{pp} for the dynamic drag torque T_{p0} resulting from preloading (for preloaded ball nuts only)

Symbol definitions:

- X** = travel
- Y** = Dynamic drag torque with preload
- 1** = Dynamometer
- T_p = $F \cdot l$ without wiper
- T_t = $F_t \cdot l$ with wiper
- l_n = Length of ball nut

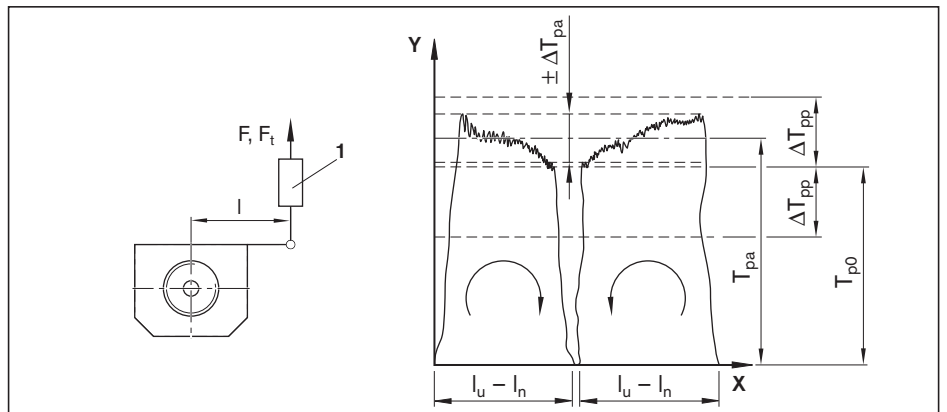

l_u / d_0 applies to	T_{p0} (Nm)		Tolerance grade							
	>	\leq	3	5	7	9	3	5	7	9
≤ 40	0	0.4	ΔT_{pp} (% of T_{p0}); $l_u \leq 4000$ mm				ΔT_{pp} (% of T_{p0}); $l_u > 4000$ mm			
	0.4	0.6	40	50	50	-	60	60	70	-
	0.6	1.0	35	40	40	-	50	50	60	-
	1.0	2.5	30	35	40	-	40	45	50	-
	2.5	6.3	25	30	35	-	35	40	45	-
	6.3	10.0	20	25	30	-	30	35	40	-
	10.0		15	20	30	-	25	30	35	-
> 40	0	0.4	50	60	60	-	60	60	70	-
	0.4	0.6	40	45	45	-	50	50	60	-
	0.6	1.0	35	40	45	-	40	45	50	-
	1.0	2.5	30	35	40	-	35	40	45	-
	2.5	6.3	25	30	35	-	30	35	40	-
	6.3	10.0	20	25	35	-	25	30	35	-
	10.0		20	25	35	-	25	30	35	-

Preload and rigidity

Nut system preload

In addition to single nuts with reduced backlash, Rexroth supplies preloaded or adjustable-preload nut systems.

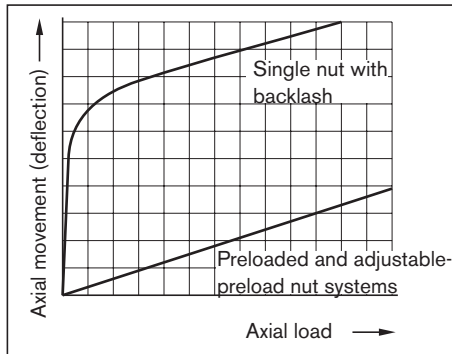

With the same preload, the rigidity behavior of these different Rexroth nut systems is virtually identical. The reason: Installation of adjustable-preload single nuts and preloaded single nuts is much more compact. The screw is typically far less rigid than the nut unit (for details see "Overall axial rigidity...").

General information:

The preload of the nut acts as additional load. For this reason, reduce the preload to the required minimum.

Preloaded single nut

Single nuts can be preloaded in an optimum way with preload classes C1, C2 or C3 by means of ball size selection.



Adjustable-preload single nut

Using adjustable-preload single nuts, the design process can be more favorably priced for many applications. You set the zero backlash or the preloading radially by means of a slot that is approximately 0.1 mm wide; refer to the section entitled "Installation". Depending on the application, we preload the nut system with preload classes C1, C2 or C3. The maximum preload is preload class C3.



Single nut with flange FED

The HP series single nut with flange is preloaded in an optimum way with preload classes C1 or C2 by means of ball size selection.



Double nut

Bracing two single nuts eliminates the axial play due to production-related issues and increases rigidity, which improves positioning accuracy.

To prevent the service life from being shortened, the preload should not amount to $\frac{1}{3}$ of the average operating load. Depending on the application, we preload the nut system with preload classes C4 or C5. The double nut is particularly suited for highly dynamic applications.



Driven nut FAR

You can preload Series HP driven nuts like a single nut using preload classes C1, C2 or C3 by means of ball size selection.

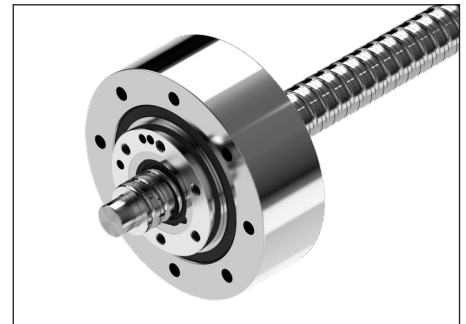

Rigidity

The rigidity of a ball screw assembly is also affected by all adjoining parts such as bearings, housing bores, nut housings, etc.

Overall axial rigidity R_{bs} of the ball screw assembly

The overall axial rigidity R_{bs} is made up of the component rigidity of the bearing R_{fb} , the screw R_S and the nut unit R_{nu} .

$$\frac{1}{R_{bs}} = \frac{1}{R_{fb}} + \frac{1}{R_S} + \frac{1}{R_{nu}} \quad 16$$

Note:

Please note that in most cases the rigidity R_S of the screw will be significantly lower than the rigidity R_{nu} of the nut unit. With size 40 x 10, for example, the rigidity R_{nu} of the nut unit is two to three times greater than the rigidity R_S of a 500 mm-long screw.

Rigidity of the bearing R_{fb}

The rigidity of the bearings corresponds to the values in the bearing manufacturer's catalog.

See the dimension tables in this catalog for the rigidity values of the bearings that Rexroth can provide.

Rigidity in the area of the nut unit R_{nu}

The rigidity in the area of the preloaded nut unit is calculated on the basis of ISO 3408-4.

See the corresponding tables for rigidity values.

Rigidity of the screw R_S

The rigidity of the screw R_S depends on the type of bearing used.

See the corresponding tables for rigidity values.

- 1 Fixed bearing of the ball screw shaft on one end.

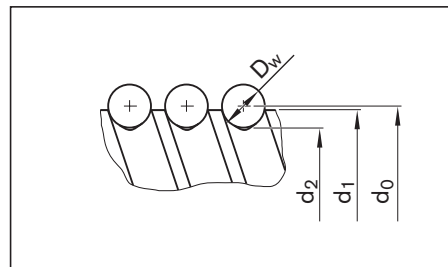
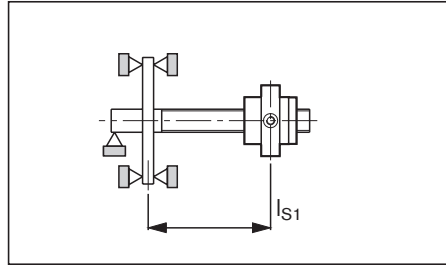

$$R_{S1} = 165 \cdot \frac{(d_0 - 0.71 \cdot D_w)^2}{l_{S1}} \quad (\text{N}/\mu\text{m}) \quad 17$$

R_{S1} = rigidity of the screw (N/μm)
 d_0 = nominal diameter (mm)
 D_w = ball diameter (mm)
 l_{S1} = Bearing - nut distance (mm)

- 2 Fixed bearing of the ball screw shaft on both ends.

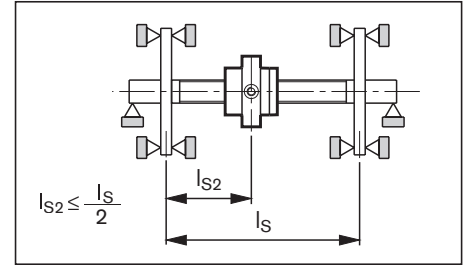

$$R_{S2} = 165 \cdot \frac{(d_0 - 0.71 \cdot D_w)^2}{l_{S2}} \cdot \frac{l_S}{l_S - l_{S2}} \quad (\text{N}/\mu\text{m}) \quad 18$$

The lowest screw rigidity occurs at the center of the screw R_{S2min} ($l_{S2} = l_S/2$) and thus equals:

$$R_{S2min} = 660 \cdot \frac{(d_0 - 0.71 \cdot D_w)^2}{l_S} \quad (\text{N}/\mu\text{m}) \quad 19$$

R_{S2} = rigidity of the screw (N/μm)
 d_0 = nominal diameter (mm)
 D_w = ball diameter (mm)
 l_S = distance between bearing and bearing (mm)
 l_{S2} = distance between bearing and nut (mm)

Preload and rigidity of single nuts

Dynamic drag torque, preload, and rigidity for screws of tolerance grades 3, 5, 7 with single nuts ZEV-E-S, FEP-E-S (C1 only), FEM-E-S, FEM-E-B, SEM-E-S and SEM-E-C (pay attention to the centering diameter D_1 that is to be set) ZEM-E-S, ZEM-E-K, ZEM-E-A, FED-E-B, FAR-B-S

- T_0 = overall dynamic drag torque
- $T_0 = T_{p0} + T_{RD}$
- C = dynamic axial load capacity
- C_0 = static load rating
- F_{PR} = pre-tensioning force
- T_{RD} = dynamic drag torque of the 2 seals
- R_S = rigidity of the screw
- R_{nu} = rigidity of the nut
- T_{p0} = dynamic drag torque without seals
- d_0 = nominal diameter
- P = lead
- D_w = ball diameter
- i = Number of load-bearing gears

The values given for dynamic drag torque are proven practical indicators for the nut preloading.

Note:
 To measure the dynamic drag torque, see the "Installation" section page 147.

Size	Load ratings		Backlash of single nut		Rigidity of the screw R_S ($\frac{N \cdot m}{\mu m}$)
	dyn. C (N)	stat. C_0 (N)	Standard (C0) (mm)	Reduced (C00) (mm)	
$d_0 \times P \times D_w - i$					
6 x 1R x 0.8 - 3	1 080	1 030	0.01	0.005	5
6 x 2R x 0.8 - 3	1 070	1 020	0.01	0.005	5
8 x 1R x 0.8 - 4	1 310	1 850	0.01	0.005	9
8 x 2R x 1.2 - 4	2 360	2 950	0.01	0.005	9
8 x 2.5R x 1.588 - 3	2 640	2 800	0.02	0.010	8
8 x 2.5R x 1.588 - 4	3 490	3 910	0.02	0.010	8
8 x 5R x 1.588 - 3	2 500	2 650	0.02	0.010	8
12 x 2R x 1.2 - 4	2 690	4 160	0.01	0.005	21
12 x 5R x 2 - 3	4 560	5 800	0.02	0.010	18
12 x 10R x 2 - 2	3 000	3 600	0.02	0.010	18
16 x 5R x 3 - 3	11 300	11 800	0.04	0.020	32
16 x 5R/L x 3 - 4	14 800	16 100	0.04	0.020	32
16 x 10R x 3 - 3	11 500	12 300	0.04	0.020	32
16 x 16R x 3 - 2	7 560	7 600	0.04	0.020	32
16 x 16R x 3 - 3	11 200	12 000	0.04	0.020	32
16 x 16R x 3 - 6	17 800	24 200	0.04	0.020	32
20 x 5R/L x 3 - 4	17 200	21 500	0.04	0.020	53
20 x 5R x 3 - 5	21 000	27 300	0.04	0.020	53
20 x 10R x 3 - 4	16 900	21 300	0.04	0.020	53
20 x 20R x 3.5 - 2	10 900	12 100	0.04	0.020	52
20 x 20R x 3.5 - 3	16 000	18 800	0.04	0.020	52
20 x 20R x 3.5 - 6	25 700	38 100	0.04	0.020	52
20 x 40R x 3.5 - 4	14 000	26 200	0.04	0.020	52
25 x 5R/L x 3 - 4	19 100	27 200	0.04	0.020	86
25 x 5R x 3 - 7	31 400	48 700	0.04	0.020	86
25 x 10R x 3 - 4	18 800	27 000	0.04	0.020	86
25 x 10R x 3 - 5	23 200	34 200	0.04	0.020	86
25 x 25R 3.5 - 2	12 100	15 100	0.04	0.020	84
25 x 25R x 3.5 - 3	17 600	23 300	0.04	0.020	84
25 x 25R x 3.5 - 4.8	19 700	39 400	0.04	0.020	84
25 x 25R x 3.5 - 6	28 500	47 100	0.04	0.020	84
32 x 5R/L x 3.5 - 4	25 900	40 000	0.04	0.020	144
32 x 5R x 3.5 - 5	31 700	50 600	0.04	0.020	144
32 x 10R x 3.969 - 5	38 000	58 300	0.04	0.020	141
32 x 20R x 3.969 - 2	16 200	21 800	0.04	0.020	141
32 x 20R x 3.969 - 3	23 600	33 700	0.04	0.020	141
32 x 20R x 3.969 - 6	38 300	67 300	0.04	0.020	141
32 x 32R x 3.969 - 2	16 100	22 000	0.04	0.020	141
32 x 32R x 3.969 - 3	23 400	34 000	0.04	0.020	141
32 x 32R x 3.969 - 4.8	26 300	57 600	0.04	0.020	141
32 x 32R x 3.969 - 6	37 900	68 000	0.04	0.020	141
32 x 64R x 3.969 - 4	21 100	49 000	0.04	0.020	141
40 x 5R/L x 3.5 - 5	34 900	64 100	0.04	0.020	232
40 x 10R/L x 6 - 4	60 000	86 400	0.07	0.035	211
40 x 10R x 6 - 5	73 400	109 300	0.07	0.035	211
40 x 10R x 6 - 6	86 500	132 200	0.07	0.035	211
40 x 12R x 6 - 4	59 900	86 200	0.07	0.035	211
40 x 16R x 6 - 4	59 600	85 900	0.07	0.035	211
40 x 20R x 6 - 3	45 500	62 800	0.07	0.035	211
40 x 20R x 6 - 8	95 500	171 100	0.07	0.035	211
40 x 25R x 6 - 4	56 900	85 800	0.07	0.035	211
40 x 25R x 6 - 8	91 400	171 700	0.07	0.035	211
40 x 30R x 6 - 4	56 300	85 100	0.07	0.035	211
40 x 30R x 6 - 8	90 400	170 300	0.07	0.035	211
40 x 40R x 6 - 2	30 600	40 300	0.07	0.035	211
40 x 40R x 6 - 3	44 400	62 300	0.07	0.035	211
40 x 40R x 6 - 6	71 500	124 500	0.07	0.035	211
50 x 5R x 3.5 - 5	38 400	81 300	0.04	0.020	373
50 x 10R x 6 - 6	95 600	166 500	0.07	0.035	345
50 x 12R x 6 - 6	95 500	166 400	0.07	0.035	345
50 x 16R x 6 - 6	95 300	166 000	0.07	0.035	345
50 x 20R x 6.5 - 3	57 500	87 900	0.07	0.035	340
50 x 20R x 6.5 - 5	90 800	149 700	0.07	0.035	340
50 x 20R x 6.5 - 8	116 500	240 000	0.07	0.035	340
50 x 25R x 6.5 - 4	56 900	85 800	0.07	0.035	211
50 x 25R x 6.5 - 6	92 600	175 100	0.07	0.035	340
50 x 30R x 6.5 - 4	71 300	118 800	0.07	0.035	340
50 x 30R x 6.5 - 8	114 500	237 700	0.07	0.035	340
50 x 40R x 6.5 - 2	38 500	55 800	0.07	0.035	340
50 x 40R x 6.5 - 3	55 800	85 900	0.07	0.035	340
50 x 40R x 6.5 - 6	89 300	171 500	0.07	0.035	340

For sizes 63 and 80, see the next page.

Preload and rigidity of single nuts

Size	Load ratings		Backlash of single nut		Rigidity of the screw
	dyn. C (N)	stat. C ₀ (N)	Standard (C0) (mm)	Reduced (C00) (mm)	R _S ($\frac{N \cdot m}{\mu m}$)
d ₀ x P x D _w - i					
63 x 10R x 6 - 6	106,600	214,300	0.07	0.035	569
63 x 20R x 6.5 - 3	63,800	112,100	0.07	0.035	563
63 x 20R x 6.5 - 5	100,700	190,300	0.07	0.035	563
63 x 20R x 6.5 - 8	130,800	292,000	0.07	0.035	563
63 x 40R x 6.5 - 2	44,300	74,300	0.07	0.035	563
63 x 40R x 6.5 - 3	64,100	114,100	0.07	0.035	563
63 x 40R x 6.5 - 6	100,000	230,600	0.07	0.035	563
80 x 10R x 6.5 - 6	130,100	291,700	0.07	0.035	938
80 x 20R x 12.7 - 6	315,200	534,200	0.11	0.055	832
80 x 40R x 12.7 - 4	216,600	367,600	0.11	0.055	832

Preload and rigidity of double nuts

Dynamic drag torque, preload, and rigidity for screws of tolerance grades 3, 5, 7 with double nuts
FDM-E-S, FDM-E-B

T₀ = overall dynamic drag torque

T₀ = T_{p0} + T_{RD}

C = dynamic axial load capacity

C₀ = static load rating

T_{RD} = dynamic drag torque of the 2 seals

R_S = rigidity of the screw

R_{nu} = rigidity of the nut

T_{p0} = dynamic drag torque without seals

d₀ = nominal diameter

P = lead

D_w = ball diameter

i = number of ball track turns

Size	Load ratings		Rigidity of the screw
	dyn. C (N)	stat. C ₀ (N)	
d ₀ x P x D _w - i			
16 x 5R x 3 - 4	14,800	16,100	32
20 x 5R x 3 - 4	17,200	21,500	53
25 x 5R x 3 - 4	19,100	27,200	86
25 x 10R x 3 - 4	18,800	27,000	86
32 x 5R x 3.5 - 4	25,900	40,000	144
32 x 10R x 3.969 - 5	38,000	58,300	141
40 x 5R x 3.5 - 5	34,900	64,100	232
40 x 10R x 6 - 4	60,000	86,400	211
40 x 10R x 6 - 6	86,500	132,200	211
40 x 20R x 6 - 3	45,500	62,800	211
50 x 5R x 3.5 - 5	38,400	81,300	373
50 x 10R x 6 - 4	66,500	109,000	345
50 x 10R x 6 - 6	95,600	166,500	345
50 x 20R x 6.5 - 5	90,800	149,700	340
63 x 10R x 6 - 4	74,200	140,500	569
63 x 10R x 6 - 6	106,600	214,300	569
63 x 20R x 6.5 - 5	100,700	190,300	563
80 x 10R x 6.5 - 6	130,100	291,700	938
80 x 20R x 12.7 - 6	315,200	534,200	832

The values given for dynamic drag torque are proven practical indicators for the nut preloading.

Note:

To measure the dynamic drag torque, see the "Installation" section page 147.

Size $d_0 \times P \times D_w - i$	Rigidity and dynamic drag torque of the single nuts								
	with preload class C1			Preload class C2			Preload class C3		
	R_{nu} (N/ μ m)	F_{pr} (N)	T_{p0} (Nm)	R_{nu} (N/ μ m)	F_{pr} (N)	T_{p0} (Nm)	R_{nu} (N/ μ m)	F_{pr} (N)	T_{p0} (Nm)
	Tolerance grade 3; 5; 7			Tolerance grade 3; 5; 7			Tolerance grade 3; 5; 7		
63 x 10R x 6 - 6	1,100	1,780	1.120	1,250	2,660	1.68	1,460	4,440	2.800
63 x 20R x 6.5 - 3	570	1,060	0.670	650	1,600	1.01	770	2,660	1.680
63 x 20R x 6.5 - 5	950	1,680	1.060	1,080	2,520	1.59	1,280	4,200	2.640
63 x 20R x 6.5 - 8	1,250	2,090	1.320	1,430	3,140	1.98	-	-	-
63 x 40R x 6.5 - 2	390	740	0.460	440	1,110	0.70	520	1,850	1.160
63 x 40R x 6.5 - 3	580	1,070	0.670	660	1,600	1.01	780	2,670	1.680
63 x 40R x 6.5 - 6	950	1,600	1.010	1,080	2,400	1.51	-	-	-
80 x 10R x 6.5 - 6	1,290	2,170	1.730	1,460	3,250	2.60	1,700	5,420	4.340
80 x 20R x 12.7 - 6	1,430	5,250	4.200	1,620	7,880	6.31	1,910	13,100	10.510
80 x 40R x 12.7 - 4	980	3,610	2.888	1,120	5,420	4.336	1,320	9,030	7.224

Size $d_0 \times P \times D_w - i$	Rigidity and dynamic drag torque of the double nuts								
	with preload class C5			with preload class C4					
	R_{nu} (N/ μ m)	F_{pr} (N)	T_{p0} (Nm)	Tolerance grade 3; 5; 7			Tolerance grade 3; 5; 7		
				R_{nu} (N/ μ m)	F_{pr} (N)	T_{p0} (Nm)	R_{nu} (N/ μ m)	F_{pr} (N)	T_{p0} (Nm)
16 x 5R x 3 - 4	320	860	0.06	360	1,230	0.08			
20 x 5R x 3 - 4	400	1,000	0.08	450	1,430	0.11			
25 x 5R x 3 - 4	470	1,110	0.11	330	1,590	0.16			
25 x 10R x 3 - 4	480	1,100	0.11	440	1,570	0.16			
32 x 5R x 3.5 - 4	570	1,510	0.19	640	2,160	0.28			
32 x 10R x 3.969 - 5	770	2,220	0.28	860	3,170	0.41			
40 x 5R x 3.5 - 5	850	2,040	0.33	950	2,910	0.47			
40 x 10R x 6 - 4	760	3,500	0.56	850	5,000	0.80			
40 x 10R x 6 - 6	1,150	5,050	0.81	1,280	7,210	1.15			
40 x 20R x 6 - 3	570	2,650	0.42	640	3,790	0.61			
50 x 5R x 3.5 - 5	1,000	2,240	0.45	1,110	3,200	0.64			
50 x 10R x 6 - 4	900	3,880	0.78	1,010	5,540	1.11			
50 x 10R x 6 - 6	1,350	5,580	1.12	1,510	7,970	1.59			
50 x 20R x 6.5 - 5	1,180	5,300	1.06	1,320	7,570	1.51			
63 x 10R x 6 - 4	1,080	4,330	1.09	1,200	6,180	1.56			
63 x 10R x 6 - 6	1,620	6,220	1.57	1,800	8,880	2.24			
63 x 20R x 6.5 - 5	1,420	5,870	1.48	1,590	8,390	2.11			
80 x 10R x 6.5 - 6	1,870	7,590	2.43	2,070	10,800	3.47			
80 x 20R x 12.7 - 6	2,130	18,400	5.88	2,380	26,300	8.41			

Frictional torques of the seals

Seal torque for single and double nuts

T_0 = overall dynamic drag torque

$T_0 = T_{p0} + T_{RD}$

T_{RD} = dynamic drag torque of the 2 seals

T_{p0} = dynamic drag torque without seals

d_0 = nominal diameter

P = lead

D_w = ball diameter

Note:

To measure the dynamic drag torque, see the "Installation" section page 147.

Size $d_0 \times P \times D_w$	Dynamic drag torque		
	Standard seal T_{RD} approx. (Nm)	reinforced seal T_{RD} approx. (Nm)	Low-friction seal $T_{RD} = 0$ Nm
6 x 1R x 0.8	-	-	✓
6 x 2R x 0.8	-	-	✓
8 x 1R x 0.8	-	-	✓
8 x 2R x 1.2	-	-	✓
8 x 2.5R x 1.588	0.015	-	✓
8 x 5R x 1.588	0.015	-	-
12 x 2R x 1.2	0.030	-	✓
12 x 5R x 2	0.030	-	✓
12 x 10R x 2	0.030	-	✓
16 x 5R x 3	0.080	-	✓
16 x 5L x 3	0.080	-	✓
16 x 10R x 3	0.080	-	✓
16 x 16R x 3	0.080	-	✓
20 x 5R x 3	0.100	-	✓
20 x 5L x 3	0.100	-	-
20 x 10R x 3	0.120	-	-
20 x 20R x 3.5	0.120	-	✓
20 x 40R x 3.5	0.040	-	✓
25 x 5R x 3	0.120	0.34	✓
25 x 5L x 3	0.120	-	-
25 x 10R x 3	0.150	0.29	✓
25 x 25R x 3.5	0.200	0.25	✓
32 x 5R x 3.5	0.250	0.51	✓
32 x 5L x 3.5	0.250	-	-
32 x 10R x 3.969	0.250	0.46	✓
32 x 20R x 3.969	0.250	0.49	✓
32 x 32R x 3.969	0.250	0.45	✓
32 x 64R x 3.969	0.250	0.45	✓
40 x 5R x 3.5	0.400	0.85	✓
40 x 5L x 3.5	0.400	-	-
40 x 10R x 6	0.400	0.91	✓
40 x 10L x 6	0.400	-	-
40 x 12R x 6	0.400	-	-
40 x 16R x 6	0.400	-	-
40 x 20R x 6	0.400	0.54	✓
40 x 25R x 6	0.400	0.54	-
40 x 30R x 6	0.400	0.54	-
40 x 40R x 6	0.400	0.54	✓
50 x 5R x 3.5	0.500	-	-
50 x 10R x 6	0.600	0.95	-
50 x 12R x 6	0.600	-	-
50 x 16R x 6	0.600	-	-
50 x 20R x 6.5	0.600	0.95	-
50 x 25R x 6.5	0.700	-	-
50 x 30R x 6.5	0.700	0.95	-
50 x 40R x 6.5	0.700	-	-
63 x 10R x 6	1.200	-	-
63 x 20R x 6.5	1.200	1.40	-
63 x 40R x 6.5	1.200	1.40	-
80 x 10R x 6.5	1.400	-	-
80 x 20R x 12.7	2.200	-	-
80 x 40R x 12.7	2.300	-	-

When retrofitting and changing over the seals, please note:

All precision screws with small leads are single-start (Figure 1). There is thus one ball raceway on the screw. Precision screws with higher leads, however, are 2-start or 4-start (Figs. 2 and 3).

“Reinforced seals” for precision screws are optionally available. This version can be identified by the opal-green coloring of the component and the material number.

Low-friction seals for precision screws are available on request. This version can be identified by the red-brown coloring of the component and the material number.

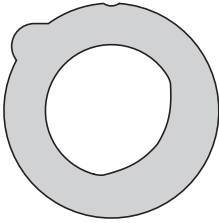
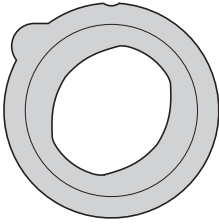
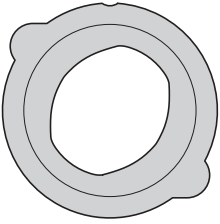
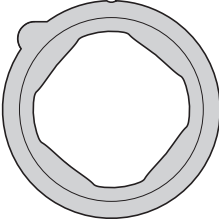
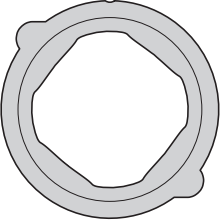
	Standard nuts	FED nut
Fig. 1 Single-start seal		
Fig. 2 Seal for the 2-start precision screw with medium lead		
Fig. 3 Seal for the 4-start precision screw with high lead		

Installing the seal

Position the nut on the screw according to the Figure. Lay the wiper seal with the nose in the recess and press until it snaps into the groove. When turning the nut on the screw, monitor the sealing lip and align it by pressing on the end face if need be. Please make sure that the sealing lip does not get damaged.

Detailed assembly instructions are included with the delivery.

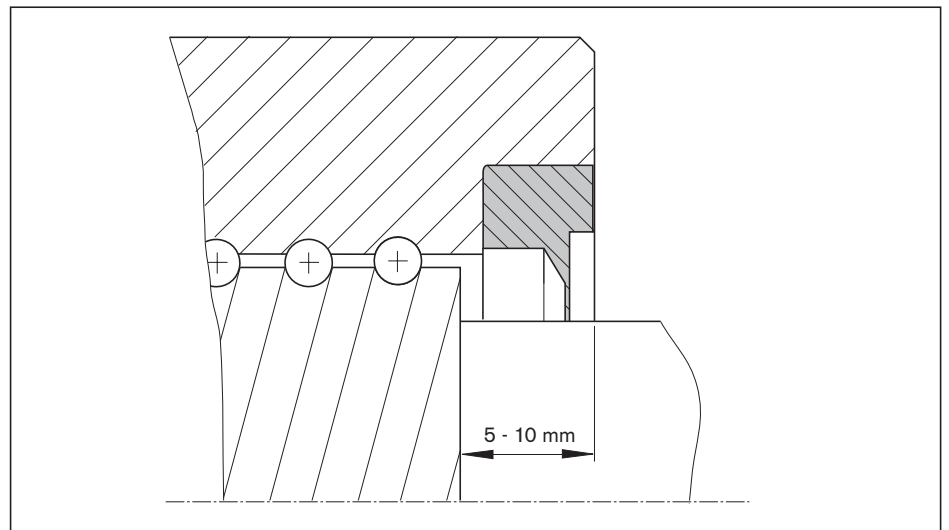

Installation

Delivery condition

Normally, Rexroth ball screws are supplied initially greased with Dynalub grease. This makes possible relubrication using oil or grease. and cartridges and cans of this grease are available. If another lubricant is used, you will need to check that it is compatible with the initial lubrication grease. In special cases, a ball screw assembly with only a preservative coating can be ordered and supplied using the appropriate ordering code.

Note

The selected lubricant must be in the nut before the machine is started.

Cleaning

Various cleaning agents can be used to degrease and wash the assembly:

- aqueous cleaning agents
- organic cleaning agents

Note

Immediately after cleaning, thoroughly dry all parts and apply a preservative coating or anti-corrosion oil.

In all cases, take care to observe the appropriate legal regulations (environmental protection, health and safety at work, etc.) as well as the specifications for the cleaning agent (e.g. handling).

Storage

Ball screw assemblies are high-quality systems that must be treated with due care. In order to prevent damage and contamination, the elements should not be removed from the protective wrapping until immediately before installation. Once they have been removed from the packaging, they must be set down on V-shaped cradles.

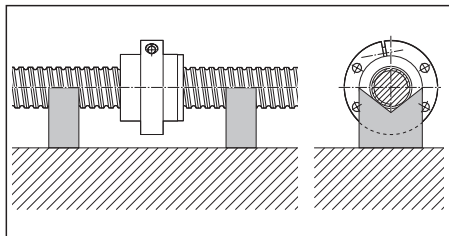

Nut mounting

Preloaded single nut double nut

These versions are always supplied on the ready-mounted nut unit on the screw. You must not disassemble the nut unit and the screw. If this is unavoidable, please contact us.

Note: In the case of ball screw assemblies with a front lube unit, do not rotate the nut and the front lube unit from the screw.

Single nut with standard backlash Single nut with reduced backlash Adjustable-preload single nut

You must only mount the nut unit on an end-machined screw using a mounting arbor. The screw journal is then used to center the mounting arbor. In the case of screw ends of Form "00", you can use a centering bore "Z" on the end face to place an auxiliary spigot in position for mounting. The external diameter of the arbor should be approximately 0.1 mm less than the root diameter of the screw. In most cases, you can use the supplied arbor with nut units. The start of the screw's thread must be rounded off carefully to avoid damage to the seal and the individual inner parts of the nut unit.

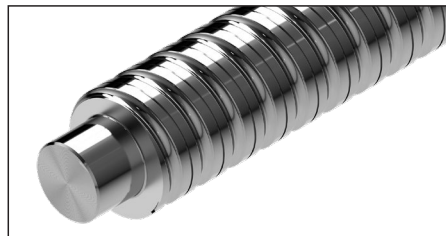

The individual mounting steps are described below. Disassembly is carried out in the reverse order. Be particularly careful; otherwise, the nut or its individual internal parts could be damaged, which would lead to premature failure of the ball screw assembly.

Individual mounting steps

Carry out installation as follows:
Remove the retaining ring (→ mounting instructions) on one side of the mounting arbor.



Push the mounting arbor with the nut to the start of the thread.

The arbor must be in contact on an axially backlash-free basis.

Now, carefully turn the nut unit onto the thread with slight axial pressure.



Do not remove the mounting arbor until the nut unit is located completely on the screw thread.



Preloading of the adjustable-preload single nut

Measuring of the dynamic drag torque with SEM-E-S and SEM-E-C.

Use an adjusting screw to restrict the clearance of the nut that is ready-mounted on the screw such that the dynamic drag torque T_{p0} achieves the value in the table \Rightarrow page 140 (with the ball screw assembly lightly oiled).

You must carry out the inspection across the entire length of the thread; if the values are different from the ones in the table, correct the setting.

After you make the setting, the centering diameter D_1 must match the values in the tables \Rightarrow page 38 and 40. Cover the head of the screw with a protective cap.

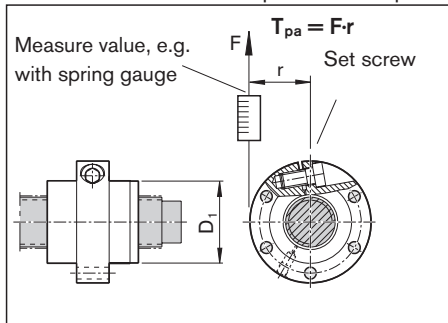

T_{pa} = currently measured dynamic drag torque

Assembly instructions are included with each delivery. If you need additional copies, please ask us.

Installation in the machine

It is not normally necessary to remove the preservative coating before installation.

- If the ball screw assembly is contaminated, you must clean it first (see "Cleaning") and re-oil it
- Push the nut unit into the mounting bore, taking care to avoid any impact force or misalignment.
- Tighten the mounting screws using a torque wrench if necessary. Maximum tightening torque for the steel/steel material pairing ($R_m \geq 370 \text{ N/mm}^2$), see table.

Steel/steel material pairing			
Screw diameter (mm)	Tightening torque (Nm)		
	Strength classes as per DIN ISO 898		
	8.8	10.9	12.9
M3	1.3	1.8	2.1
M4	2.7	3.8	4.6
M5	5.5	8.0	9.5
M6	9.5	13.0	16.0
M8	23.0	32.0	39.0
M10	46.0	64.0	77.0
M12	80.0	110.0	135.0
M14	125.0	180.0	215.0
M16	195.0	275.0	330.0
M18	280.0	400.0	470.0
M20	390.0	560.0	650.0

- The maximum tightening torques specified in the table below apply to the steel/aluminum or aluminum/aluminum material pairings ($R_m \geq 280 \text{ N/mm}^2$). When driving screws into aluminum, the length of thread engagement should be at least 1.5 times the screw diameter.

Mounting screws

⚠ Always make sure the screws are secure where there are high screw loads!

Steel/aluminum and aluminum/aluminum material pairings			
Screw diameter (mm)	Tightening torque (Nm)		
	Strength classes as per DIN ISO 898		
	8.8	10.9	12.9
M3	1.2	1.2	1.2
M4	2.4	2.4	2.4
M5	4.8	4.8	4.8
M6	8.5	8.5	8.5
M8	20.0	20.0	20.0
M10	41.0	41.0	41.0
M12	70.0	70.0	70.0
M14	110.0	110.0	110.0
M16	175.0	175.0	175.0
M18	250.0	250.0	250.0
M20	345.0	345.0	345.0

Tightening torques for fastening screws according to VDI 2230 where $\mu_G = \mu_K = 0.125$

Aligning the ball screw assembly in the machine

A gauge¹⁾ with a self-aligning contact pad is available from Rexroth for easy alignment of the ball screw assembly.

Two pads of different lengths are available which can be used depending on the screw lead:

- Part number R3305 131 19 length 33 mm for leads < 20
- Part number R3305 131 21 length 50 mm for leads > 20

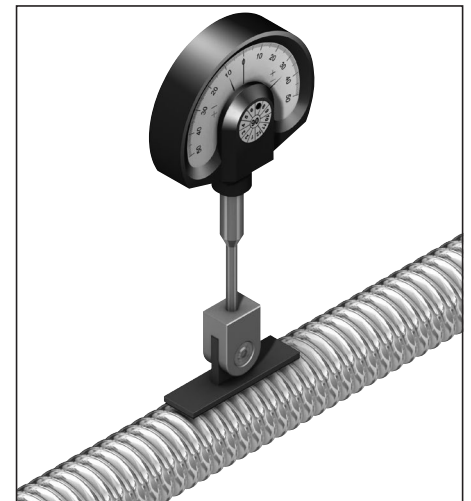

1) The dial gauge is not supplied

Installation tolerances

Note

Any alignment errors can lead to premature failure of the ball screw assembly, which means that they are not allowed!

To ensure that a BASA can actually achieve the calculated service life and performance, its system-related requirements and limitations must be taken into account at the design stage. Screw assemblies are not suitable for transferring radial forces and torques, such as may be caused by misalignments during installation. The following sections illustrate the most important principles for achieving designs that will be compatible with the screw drive system and its requirements.

When using BASAs, the specified installation tolerances must be observed when designing and building the adjoining structures. The first basic principle is: The higher the BASA's precision and preload, the more accurate the adjoining structures must be. This applies in particular to applications in which the nut travels close up to the end bearings since, in this area, the risk of distortive stresses and therefore of additional loads is very high.

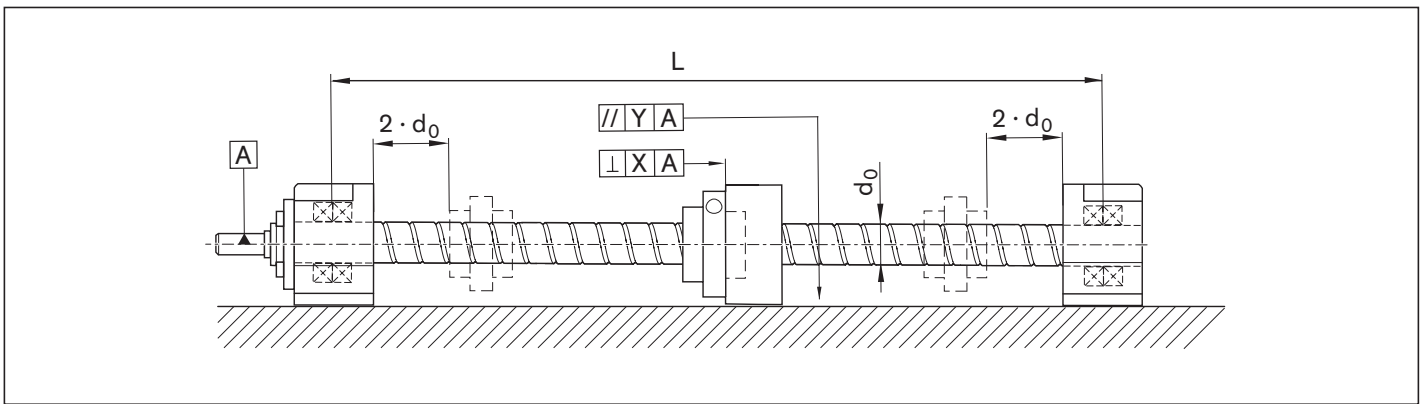

Parallelism offset and details of the rectangularity between the screw shaft axis and the location face of the nut housing.

- L = distance between end bearings (mm)
- d_0 = nominal diameter of screw (mm)
- X = permissible deviation from rectangularity:
The tolerance applies to a surface that must lie between two planes spaced at a distance X from each other which are perpendicular to the reference axis A. (mm)
- Y = Permissible parallelism offset between the guide and the ball screw assembly (mm)

The adjacent table shows the most important recommended tolerances for ball screw assemblies as a function of the preload.

These tolerances include the rectangularity of the nut housing (or adjoining structure) relative to the screw axis. The tolerances for parallelism between the guide and the ball screw assembly must also be complied with.

Minimum distance of the nut from the end bearings $> 2 \cdot d_0$

Any alignment errors can lead to premature breakdown of the ball screw assembly!

Preload option	X (mm)	Y (mm)
Backlash	0.04	0.04
Preloaded	0.02	0.02

Lubrication

General lubrication instructions

- ▶ All informations on lubrication is based on test values and field experience and are recommendations from Bosch Rexroth.
- ⚠ Do not use greases containing solid particles (e.g. graphite or MoS₂)!
- ⚠ If other lubricants are used, this may lead to a reduction in the relubrication intervals, the achievable travel in short-stroke applications, and the load capacities. Possible chemical interactions between the plastic materials, lubricants and preservative oils must also be taken into account.
- ⚠ If your application makes greater environmental demands (i.e. cleanroom, vacuum, foodstuff application, strong or aggressive metal-working fluids, or extreme temperatures) please contact us, since a special test, and possibly a special lubricant, will be required. Please have all information about your application to hand.
- ⚠ When using in other sectors, e.g.: food industry, clean room, vacuum etc. or at extreme temperatures, or if the lubrication is exposed to process media, the standard initial lubrication and anti-corrosion agents used prior to shipment may not be suitable, or they may be incompatible with the relubrication lubricant. In this case, please consult us in advance!
- ⚠ Even under normal operating conditions, the system must be relubricated at the latest after 2 years due to aging of the grease. Please note the reduced load ratings according to the technical notes.
- ▶ In general, you should not apply the lubricant all in one go; rather, apply several smaller amounts.
- ▶ In the case of a short stroke, (stroke \leq nut length, L), it is advisable to carry out a lubricating stroke more often. In this case, there is a risk, amongst other things, that low-viscosity lubricants drop out. Please note the information about reducing the load rating in "Technical notes" on page 133. Please consult our regional centers regarding short stroke applications. You can find your local contact person at: www.boschrexroth.com/contact

Grease lubrication With a grease gun or a progressive lubrication system in the case of ball screw assemblies > Ø 12 mm

Lubricating grease

We recommend using **Dynalub 510** with the following properties:

- NLGI grade 2 lithium-based high-performance grease as per DIN 51818 (KP2K-20 according to DIN 51825)
- Good water resistance
- Corrosion protection
- Temperature range: –20 to +80 °C

Under conventional environmental conditions, this ground-fiber, homogeneous grease is ideally suited for the lubrication of linear elements:

- For loads of up to 50% C
- For short-stroke applications ≥ 1 mm
- For the permissible speed range of ball screw assemblies

You can download product and safety data sheets from our website at: www.boschrexroth.de.

Please also observe the information on page 168.

Material numbers for Dynalub 510:

- R3416 037 00 (cartridge 400 g)
- R3416 035 00 (hobbock 25 kg)

Initial lubrication of the ball screw assemblies (basic lubrication)

Fully assembled BASAs with a diameter greater than 12 mm are prelubricated at the factory with Dynalub 510.

When individual parts are supplied (nut on mounting arbor) or with versions without basic lubrication at the factory, you must apply double the quantity of lubricant stated in the “Lubricant quantities - Relubrication” table via the nut’s lube hole before commissioning.

The positioning and traversing instructions (see figure below) must be complied with.

When using progressive lubrication systems, ensure that all the lines and distributors (including the connection to the BASA nut unit) are filled before carrying out basic lubrication or relubrication.

Relubricating the ball screw assemblies

If the relubrication interval according to the diagram on page 152 has been reached, relubricate the amount stated in Table “Amount of lubricant for relubrication” on page 154.

In this connection, you must comply with the nut position and traversing path shown in the “Positioning and traversing instructions” illustration.

Positioning and traversing instructions

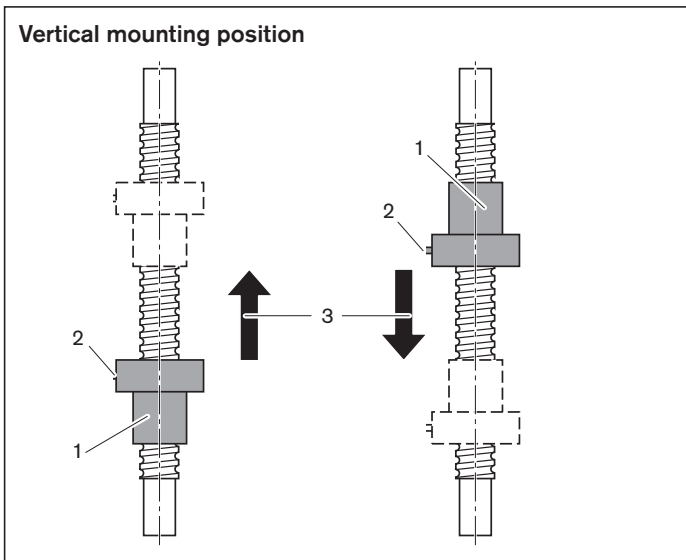
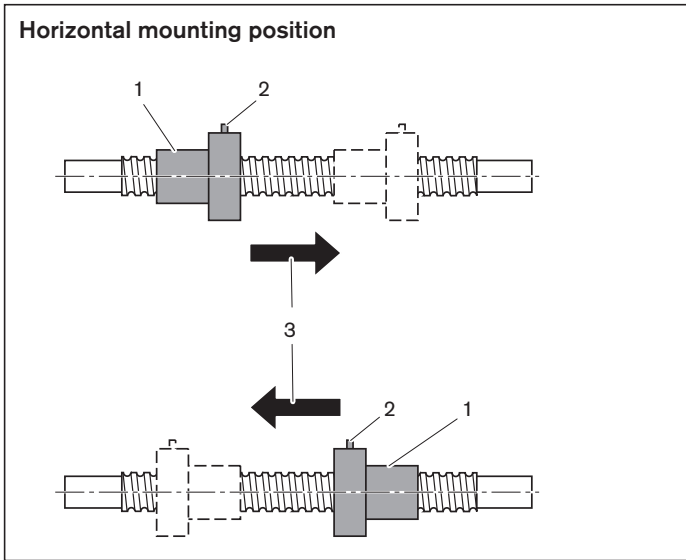

- 1 Position of the nut during lubrication
- 2 Flange with lube port (if installed horizontally, the port should be at the top if possible)
- 3 Direction of travel after lubrication. Traversing path should be at least 3x the nut length.

Load-dependent re-greasing intervals in the case of grease lubrication with a grease gun or a progressive lubrication system in the case of ball screw assemblies > Ø 12 mm ("dry axes")

This applies to the following conditions:

- Dynalub 510 grease or, alternatively, Castrol Longtime PD 2, Elkalub GLS 135/N2 grease
- No exposure to media
- Standard seals
- Driven screws
- Not mission critical operation
- Ambient temperature: $T = 10$ to 40 °C

s = relubrication interval
in millions of revolutions (10^6 revolutions)
 C = dynamic load rating (N)
 F_m = equivalent dynamic axial load (N)
 d_0 = nominal diameter (mm)

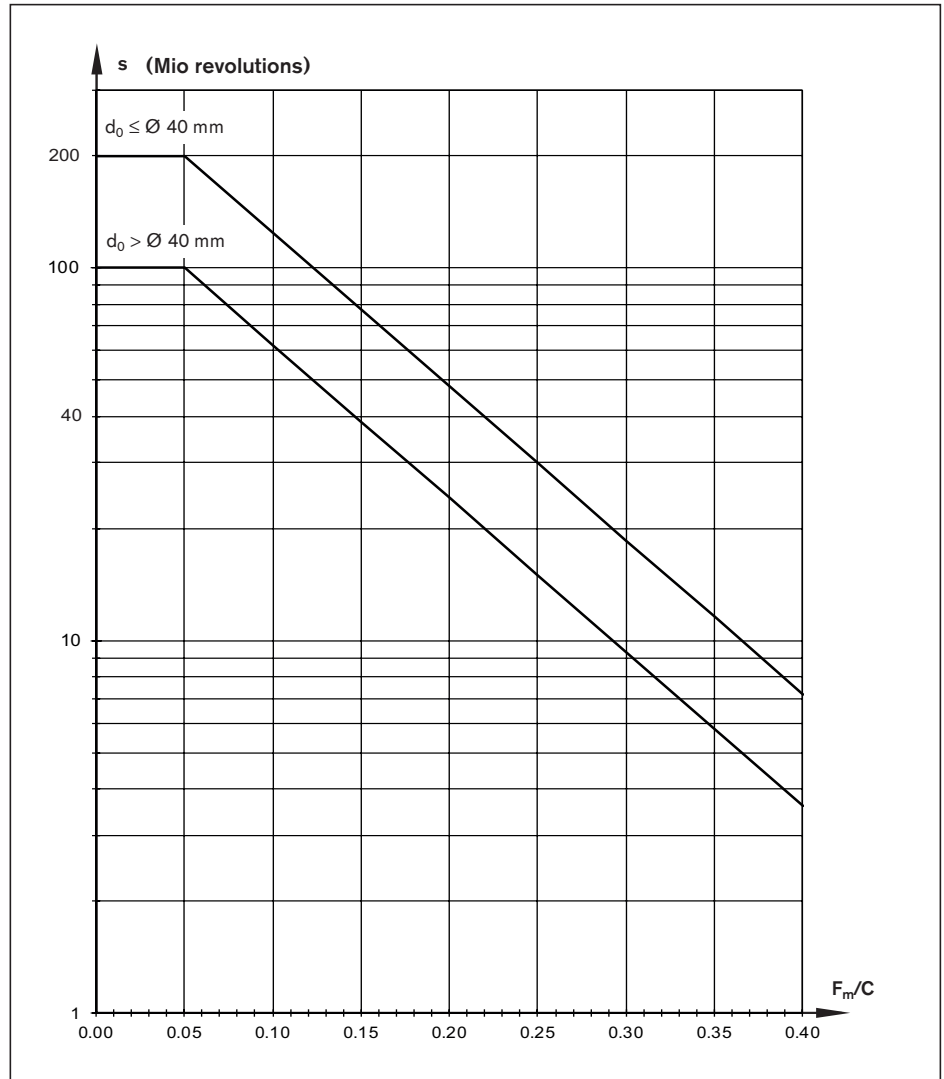

Conversion of the relubrication interval s from millions of revolutions to kilometers:

$$s \text{ in kilometers} = \frac{s \text{ in millions (of revs)} \cdot \text{lead } P \text{ (mm)}}{10^6}$$

Example:

$$s \text{ in kilometers} = \frac{200 \cdot 10^6 \text{ (revs)} \cdot 16 \text{ (mm)}}{10^6} = 3200 \text{ km}$$

Notes

The load ratio F_m/C is the quotient of the equivalent dynamic axial load F_m and the dynamic load rating C (see "Calculation").

At extreme operating conditions, please consult us as special consideration may be required for the lubrication intervals.

These operating conditions include low medium rotary speeds n_m , increased ambient temperatures and high loads $F_m/C > 0.4$.

If you are using a progressive lubrication system, please take into account the minimum metering quantity of 0.03 cm^3 .

Please also note the general lubrication information on page 149.

Grease lubrication With a grease gun or a progressive lubrication system in the case of ball screw assemblies > Ø 12 mm

Amount of lubricant for relubrication

Size $d_0 \times P \times D_w - i$	Amount of lubricant for relubrication (cm ³)		
	FED-E-B / FEM-E-B / FEM-E-S / FEP-E-S SEM-E-C / SEM-E-S / ZEM-E-S / ZEM-E-K / ZEM-E-A	ZEV-E-S	FDM-E-B / FDM-E-S
16x5Rx3 - 3	–	0.9	–
16x5R/Lx3 - 4	0.70	–	1.75
16x10Rx3 - 3	0.85	1.10	–
16x16Rx3 - 2	0.95	–	–
16x16Rx3 - 3	1.20	–	–
16x16Rx3 - 6	1.35	–	–
20x5R/Lx3 - 4	1.00	1.30	2.95
20x5Rx3 - 5	1.15	–	–
20x10Rx3 - 4	1.50	–	–
20x20Rx3.5 - 2	1.85	–	–
20x20Rx3.5 - 3	2.40	–	–
20x20Rx3.5 - 6	2.50	–	–
20x40Rx3.5 - 4	1.75	–	–
25x5R/Lx3 - 4	1.50	–	3.50
25x5Rx3 - 7	–	1.95	–
25x10Rx3 - 4	1.85	–	4.15
25x10Rx3 - 5	–	2.05	–
25x25Rx3.5 - 2	2.65	–	–
25x25Rx3.5 - 3	3.45	–	–
25x25Rx3.5 - 4.8	1.65	–	–
25x25Rx3.5 - 6	3.90	–	–
32x5Lx3.5 - 4	2.50	–	–
32x5Rx3.5 - 4	2.15	–	4.90
32x5Rx3.5 - 5	–	2.40	–
32x10Rx3.969 - 5	3.05	3.25	6.65
32x20Rx3.969 - 2	2.80	–	–
32x20Rx3.969 - 3	3.55	–	–
32x20Rx3.969 - 6	3.70	–	–
32x32Rx3.969 - 2	4.05	–	–
32x32Rx3.969 - 3	5.45	–	–
32x32Rx3.969 - 4.8	2.85	–	–
32x32Rx3.969 - 6	6.20	–	–
32x64Rx3.969 - 4	3.35	–	–
40x5Lx3.5 - 5	3.35	–	–
40x5Rx3.5 - 5	2.95	–	7.60
40x10Lx6 - 4	6.50	–	–
40x10Rx6 - 4	6.65	–	16.75
40x10Rx6 - 5	7.70	–	–
40x10Rx6 - 6	8.15	–	19.70
40x12Rx6 - 4	6.75	–	–
40x16Rx6 - 4	9.15	–	21.35
40x20Rx6 - 3	8.70	–	20.55
40x20Rx6 - 8	9.35	–	–
40x25Rx6 - 4	10.84	–	–
40x25Rx6 - 8	10.99	–	–
40x30Rx6 - 4	11.95	–	–
40x30Rx6 - 8	12.29	–	–
40x40Rx6 - 2	10.40	–	–
40x40Rx6 - 3	14.30	–	–

Size $d_0 \times P \times D_w - i$	Amount of lubricant for relubrication (cm ³)		
	FED-E-B / FEM-E-B / FEM-E-S / FEP-E-S SEM-E-C / SEM-E-S / ZEM-E-S / ZEM-E-K / ZEM-E-A	ZEV-E-S	FDM-E-B / FDM-E-S
40x40Rx6 - 6	15.00	-	-
50x5Rx3.5 - 5	4.65	-	11.70
50x10Rx6 - 4	-	-	21.90
50x10Rx6 - 6	10.75	-	25.55
50x12Rx6 - 6	11.60	-	-
50x16Rx6 - 6	16.15	-	-
50x20Rx6.5 - 3	12.65	-	-
50x20Rx6.5 - 5	17.35	-	34.75
50x20Rx6.5 - 8	9.90	-	-
50x25Rx6.5 - 4	14.20	-	-
50x25Rx6.5 - 6	10.45	-	-
50x30Rx6.5 - 4	14.73	-	-
50x30Rx6.5 - 8	14.81	-	-
50x40Rx6.5 - 2	15.45	-	-
50x40Rx6.5 - 3	20.65	-	-
50x40Rx6.5 - 6	19.15	-	-
63x10Rx6 - 4	-	-	25.55
63x10Rx6 - 6	12.15	-	30.00
63x20Rx6.5 - 3	15.45	-	-
63x20Rx6.5 - 5	21.35	-	43.75
63x20Rx6.5 - 8	14.35	-	-
63x40Rx6.5 - 2	18.90	-	-
63x40Rx6.5 - 3	25.40	-	-
63x40Rx6.5 - 6	26.95	-	-
80x10Rx6.5 - 6	19.10	-	66.00
80x20Rx12.7 - 6	65.50	-	132.75
80x40Rx12.7 - 4	72.84	-	-

Note: The sizes that are listed in the table are not available for all nut types.
 You can find the respective size range in the chapter entitled "Nuts" from page 24 onward.

Relubrication for driven nut FAR

For NLGI grade 2 greases (using grease gun)

The driven nut can be supplied with grease via the outer race of the angular-contact thrust ball bearing. It must simply be noted that the nut must be stationary during the lubricating procedure. The nut can however be in any position on the screw.
 This provides a very simple solution to the problem of a rotating lube port on the nut unit itself. Two lube ports (M6) with radial or axial access are provided. On delivery, both are sealed by setscrews. The lube port can be opened by removing the set screw.

For FAR with or without timing belt side drive the following applies:

- Can be relubricated with NLGI Class 2 grease when stationary via the stationary lube port of the bearing outer race
- screw liquid-cooled on request
- optional lubrication via screw

FAR size	BASA size $d_0 \times P \times D_w - i$	Relubrication quantity (cm ³)
32	32 x 10R x 3.969 - 5	3.5
	32 x 20R x 3.969 - 3	4.0
	32 x 32R x 3.969 - 3	6.0
40	40 x 10R x 6 - 5	8.4
	40 x 20R x 6 - 3	9.8
	40 x 40R x 6 - 3	16.1
50	50 x 10R x 6 - 6	12.2
	50 x 20R x 6.5 - 5	19.5
	50 x 40R x 6.5 - 3	23.3
63	63 x 10R x 6 - 6	13.8
	63 x 20R x 6.5 - 5	24.0
	63 x 40R x 6.5 - 3	28.7

Liquid grease lubrication with a single-line piston distributor system and Liquid grease lubrication with ball screw assemblies $\leq \varnothing 12$ mm

Lubricating grease

We recommend using **Dynalub 520** with the following properties:

- Lithium-based, high-performance grease of NLGI grade 00 according to DIN 51818 (GP00K-20 according to DIN 51826)
- Good water resistance
- Corrosion protection
- Temperature range: -20 to +80 °C

Under conventional environmental conditions, this ground-fiber, homogeneous grease is ideally suited for the lubrication of linear elements:

- In single-line one-point lubrication systems
- For loads of up to 50% C
- For short-stroke applications ≥ 1 mm
- For the permissible speed range of ball screw assemblies
- With miniature versions

You can download product and safety data sheets from our website at: www.boschrexroth.de.

Please also observe the information on page 168

Material numbers for Dynalub 520:

- R3416 043 00 (cartridge 400 g)
- R3416 042 00 (bucket 5 kg)
- R0419 090 01 (5 ml maintenance kit)

Initial lubrication of the ball screw assemblies (basic lubrication)

Fully assembled BASAs with a diameter less than or equal to 12 mm are prelubricated at the factory with Dynalub 520.

When individual parts are supplied (nut on mounting arbor) or with versions without basic lubrication at the factory, you must apply double the quantity of lubricant stated in table “Amount of lubricant for relubrication” on page 160 via the nut’s lube hole before commissioning.

The positioning and traversing instructions in the illustration below must be complied with.

When using single-line distributor systems, care should be taken that all lines and the piston distributors (including the connection to the BASA nut) are filled before performing basic lubrication or relubrication. In the case of ball screw assemblies $\leq \varnothing 12$ mm, it is advisable to use the maintenance set.

Relubricating the ball screw assemblies

Apply the relubrication quantity according to Table “Amount of lubricant for relubrication” on page 160 to the lube port until the specified relubrication interval shown in the diagram on page 158 has been reached.

The pulse count that is needed for this is the integer quotient of the relubrication amount according to table “Amount of lubricant for relubrication” on page 160 and the piston distributor size.

In this connection, you must ensure that the smallest piston distributor size of 0.03 cm³ is not fallen short of.

The lubricant cycle time can then be obtained by dividing the relubrication interval by the calculated pulse count.

In this connection, you must comply with the nut position and traversing path shown in the “Positioning and traversing instructions” illustration.

Positioning and traversing instructions

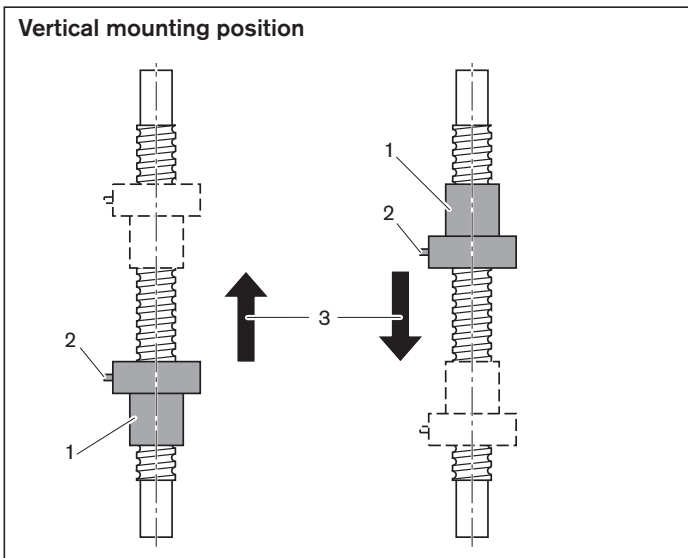
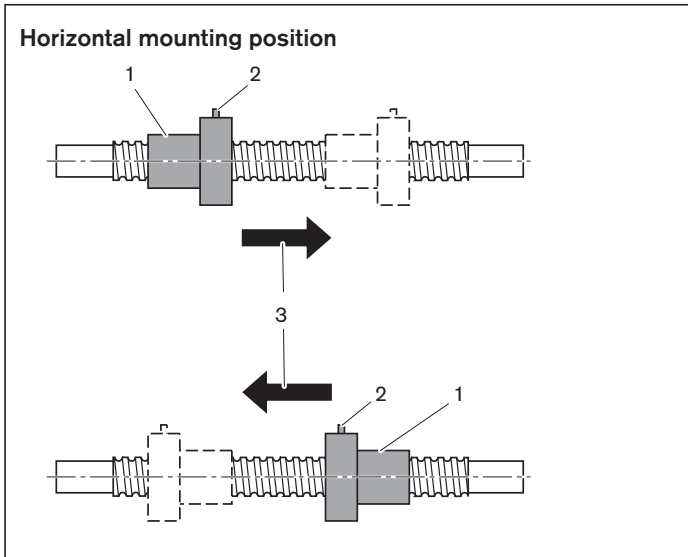

- 1 Position of the nut during lubrication
- 2 Flange with lube port (if installed horizontally, the port should be at the top if possible)
- 3 Direction of travel after lubrication. Traversing path should be at least 3x the nut length.

Load-dependent re-greasing intervals in the case of a single-line piston distributor system and liquid grease lubrication with ball screw assemblies $\leq \varnothing 12$ mm ("dry axes")

This applies to the following conditions:

- Dynalub 520 grease or, alternatively, Castrol Longtime PD 00, Elkalub GLS 135/N00 grease
- No exposure to media
- Standard seals
- Driven screws
- Not mission critical operation
- Ambient temperature: $T = 10$ to 40 °C

s = relubrication interval in millions of revolutions (10^6 revolutions)
 C = dynamic load rating (N)
 F_m = equivalent dynamic axial load (N)
 d_0 = nominal diameter (mm)

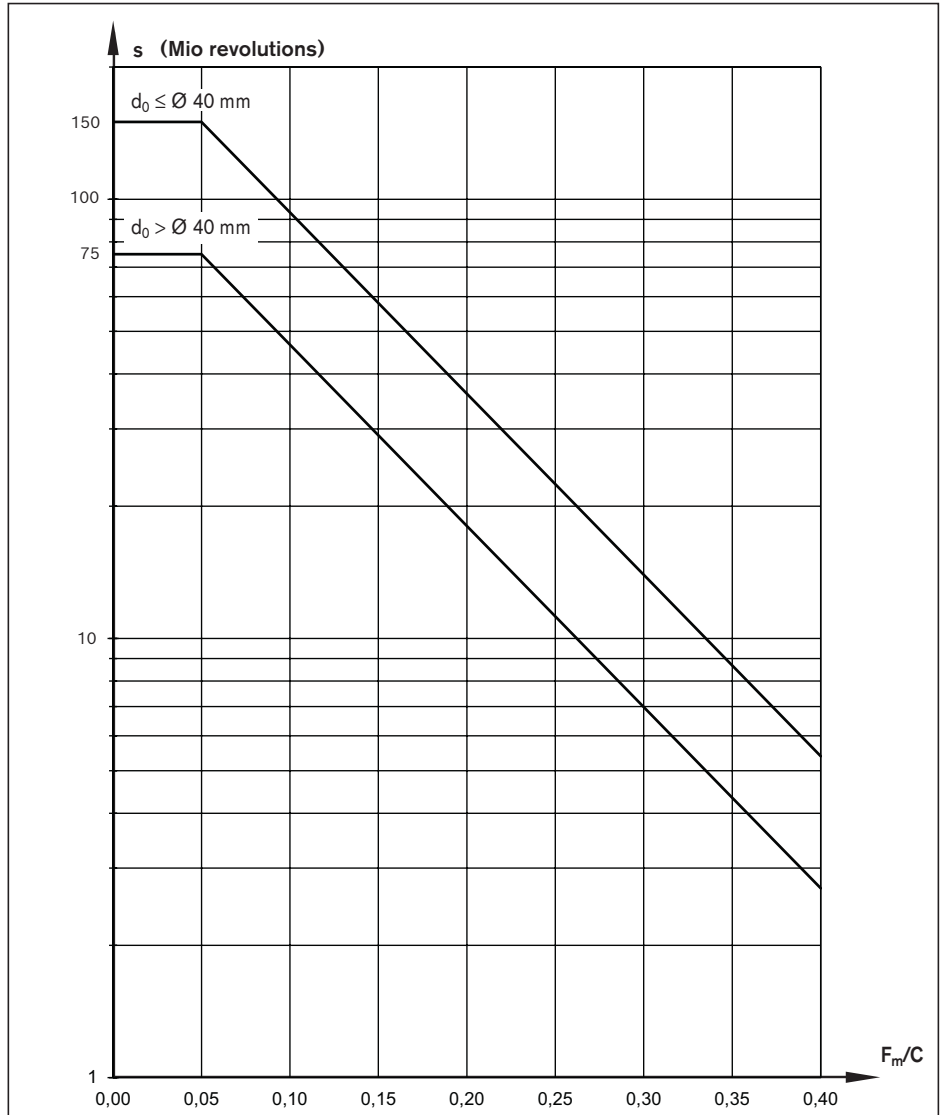

Conversion of the relubrication interval s from millions of revolutions to kilometers:

$$s \text{ in kilometers} = \frac{s \text{ in millions (of revs)} \cdot \text{lead } P \text{ (mm)}}{10^6}$$

Example:

$$s \text{ in kilometers} = \frac{37,5 \cdot 10^6 \text{ (revs)} \cdot 16 \text{ (mm)}}{10^6} = 600 \text{ km}$$

Notes

The load ratio F_m/C is the quotient of the equivalent dynamic axial load F_m and the dynamic load rating C (see "Calculation").

At extreme operating conditions, please consult us as special consideration may be required for the lubrication intervals.

These operating conditions include low medium rotary speeds n_m , increased ambient temperatures and high loads $F_m/C > 0.4$.

When using a single-line distributor system, you must ensure that the smallest piston distributor size of 0.03 cm^3 is not fallen short of.

We recommend using piston distributors from SKF. They should be installed as close as possible to the lube ports of the ball screw assembly nut.

Long lines and small line diameters should be avoided, and the lines should be laid on an upward slant.

If other consumers are connected to the single-line centralized lubrication system, the weakest link in the chain determines the lubrication cycle time.

Pumping or storage tanks for the lubricant should be fitted either with a stirrer or a follower piston to guarantee the flow of lubricant (to avoid funneling in the tank).

Please also note the general lubrication information on page 149.

Liquid grease lubrication with a single-line piston distributor system and Liquid grease lubrication with ball screw assemblies $\leq \varnothing 12$ mm

Amount of lubricant for relubrication

Size $d_0 \times P \times D_w - i$	Amount of lubricant for relubrication (cm ³)		
	FED-E-B / FEM-E-B / FEM-E-S / FEP-E-S SEM-E-C / SEM-E-S / ZEM-E-S / ZEM-E-K / ZEM-E-A	ZEV-E-S	FDM-E-B / FDM-E-S
6x1Rx0.8-3	0.05	–	–
6x2Rx0.8-3	0.05	–	–
8x1Rx0.8-4	0.06	–	–
8x2Rx1.2-4	0.07	–	–
8x2.5Rx1.588-3	0.11	–	–
8x2.5Rx1.588-4	–	0.14	–
8x5Rx1.588-3	0.12	–	–
12x2Rx1.2-4	0.17	–	–
12x5Rx2-3	0.33	0.33	–
12x10Rx2-2	0.33	0.33	–
16x5Rx3-3	–	0.90	–
16x5R/Lx3-4	0.70	–	1.75
16x10Rx3-3	0.85	1.10	–
16x16Rx3-2	0.95	–	–
16x16Rx3-3	1.20	–	–
16x16Rx3-6	1.35	–	–
20x5R/Lx3-4	1.00	1.30	2.95
20x5Rx3-5	1.15	–	–
20x10Rx3-4	1.50	–	–
20x20Rx3.5-2	1.85	–	–
20x20Rx3.5-3	2.40	–	–
20x20Rx3.5-6	2.50	–	–
20x40Rx3.5-4	1.75	–	–
25x5R/Lx3-4	1.50	–	3.50
25x5Rx3-7	–	1.95	–
25x10Rx3-4	1.85	–	4.15
25x10Rx3-5	–	2.05	–
25x25Rx3.5-2	2.65	–	–
25x25Rx3.5-3	3.45	–	–
25x25Rx3.5-4.8	1.65	–	–
25x25Rx3.5-6	3.90	–	–
32x5Lx3.5-4	2.50	–	–
32x5Rx3.5-4	2.15	–	4.90
32x5Rx3.5-5	–	2.40	–
32x10Rx3.969-5	3.05	3.25	6.65
32x20Rx3.969-2	2.80	–	–
32x20Rx3.969-3	3.55	–	–
32x20Rx3.969-6	3.70	–	–
32x32Rx3.969-2	4.05	–	–
32x32Rx3.969-3	5.45	–	–
32x32Rx3.969-4.8	2.85	–	–
32x32Rx3.969-6	6.20	–	–
32x64Rx3.969-4	3.35	–	–
40x5Lx3.5-5	3.35	–	–
40x5Rx3.5-5	2.95	–	7.60
40x10Lx6-4	6.50	–	–
40x10Rx6-4	6.65	–	16.75
40x10Rx6-5	7.70	–	–
40x10Rx6-6	8.15	–	19.70
40x12Rx6-4	6.75	–	–
40x16Rx6-4	9.15	–	21.35
40x20Rx6-3	8.70	–	20.55
40x20Rx6-8	9.35	–	–
40x25Rx6-4	10.85	–	–
40x25Rx6-8	11.00	–	–

Size $d_o \times P \times D_w - i$	Amount of lubricant for relubrication (cm ³)		
	FED-E-B / FEM-E-B / FEM-E-S / FEP-E-S SEM-E-C / SEM-E-S / ZEM-E-S / ZEM-E-K / ZEM-E-A	ZEV-E-S	FDM-E-B / FDM-E-S
40x30Rx6-4	11.95	-	-
40x30Rx6-8	12.20	-	-
40x40Rx6-2	10.40	-	-
40x40Rx6-3	14.30	-	-
40x40Rx6-6	15.00	-	-
50x5Rx3.5-5	4.65	-	11.70
50x10Rx6-4	-	-	21.90
50x10Rx6-6	10.75	-	25.55
50x12Rx6-6	11.60	-	-
50x16Rx6-6	16.15	-	-
50x20Rx6.5-3	12.65	-	-
50x20Rx6.5-5	17.35	-	34.75
50x20Rx6.5-8	9.90	-	-
50x25Rx6.5-6	10.45	-	-
50x30Rx6.5-4	14.73	-	-
50x30Rx6.5-6	14.80	-	-
50x40Rx6.5-2	15.45	-	-
50x40Rx6.5-3	20.65	-	-
50x40Rx6.5-6	19.15	-	-
63x10Rx6-4	-	-	25.55
63x10Rx6-6	12.15	-	30.00
63x20Rx6.5-3	15.45	-	-
63x20Rx6.5-5	21.35	-	43.75
63x20Rx6.5-8	14.35	-	-
63x40Rx6.5-2	18.90	-	-
63x40Rx6.5-3	25.40	-	-
63x40Rx6.5-6	26.95	-	-
80x10Rx6.5-6	19.10	-	66.00
80x20Rx12.7-6	65.50	-	132.75
80x40Rx12.7-4	72.84	-	-

Note: The sizes that are listed in the table are not available for all nut types.
You can find the respective size range in the chapter entitled “Nuts” from page 24 onward.

Oil lubrication with a single-line piston distributor system

Oil lubricant

We recommend using **Shell Tonna S 220** with the following properties:

- Special demulsifying oil CLP or CGLP as per DIN 51517-3 for machine bed tracks and tool guides
- A blend of highly refined mineral oils and additives
- Can be used even when mixed with significant quantities of metalworking fluids

Initial lubrication of the ball screw assemblies (basic lubrication)

Fully assembled BASAs with a diameter less than or equal to 12 mm are prelubricated at the factory with Dynalub 520.

Fully assembled BASAs with a diameter greater than 12 mm are prelubricated at the factory with Dynalub 510.

When individual parts are supplied (nut on mounting arbor) or in the case of special designs without basic lubrication at the factory, you must apply double the quantity of lubricant stated in table "Amount of lubricant for oil lubrication" on page 162 via the nut's lube hole before commissioning.

The positioning and traversing instructions in the illustration below must be complied with.

When using single-line distributor systems, care should be taken that all lines and the piston distributors (including the connection to the BASA nut) are filled before performing basic lubrication or relubrication.

Relubricating the ball screw assemblies

Apply the relubrication quantity according to Table "Amount of lubricant for oil lubrication" on page 162 to the lube port until the specified relubrication interval in the diagrams on page 164 has been reached.

The pulse count that is needed for this is the integer quotient of the relubrication amount according to table "Amount of lubricant for oil lubrication" on page 162 and the piston distributor size.

In this connection, you must ensure that the smallest piston distributor size of 0.03 cm³ is not fallen short of.

The lubricant cycle time can then be obtained by dividing the relubrication interval by the calculated pulse count.

In this connection, you must comply with the nut position and traversing path shown in the "Positioning and traversing instructions" illustration.

Amount of lubricant for oil lubrication

Note:

In the case of double-threaded FED-E-B single flange nuts and oil lubrication, the quantities for initial and relubrication increase by 20%.

Nominal diameter d ₀ (mm)	Initial lubrication V _e (cm ³)	Relubrication V _n (cm ³)
6 / 8 / 12 / 16	0.3	0.03
20 / 25 / 32	0.6	0.06
40	2.0	0.40
50 / 63	4.0	0.80
80	8.0	1.60

Positioning and traversing instructions

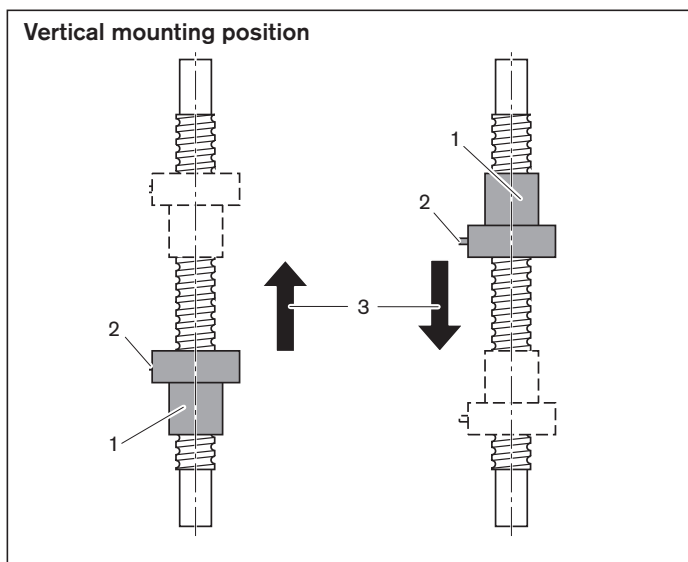
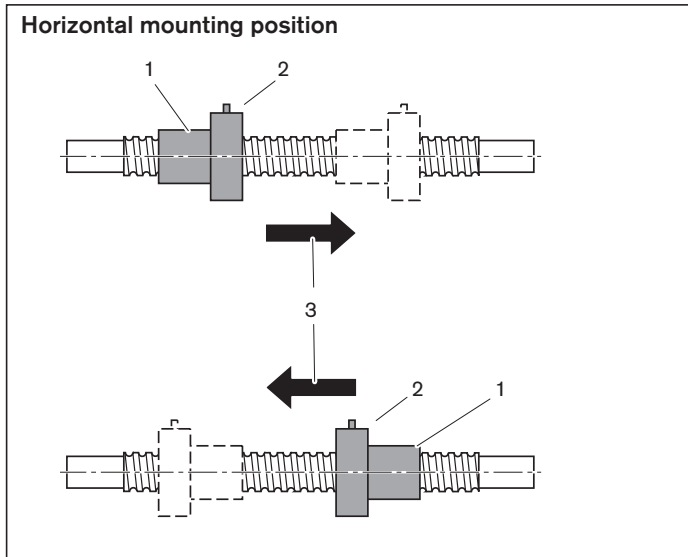

- 1 Position of the nut during lubrication
- 2 Flange with lube port (if installed horizontally, the port should be at the top if possible)
- 3 Direction of travel after lubrication. Traversing path should be at least 3x the nut length.

Load-dependent lubrication in the case of oil lubrication with single-line piston distributor systems ("dry axes")

This applies to the following conditions:

- Lubricating oil is Shell Tonna S 220
- No exposure to media
- Standard seals
- Driven screws
- Not mission critical operation
- Ambient temperature: $T = 10$ to 40 °C

s = relubrication interval
in millions of revolutions 10^6 rev.
or hours (h)
 C = dynamic load rating (N)
 F_m = equivalent dynamic axial load (N)

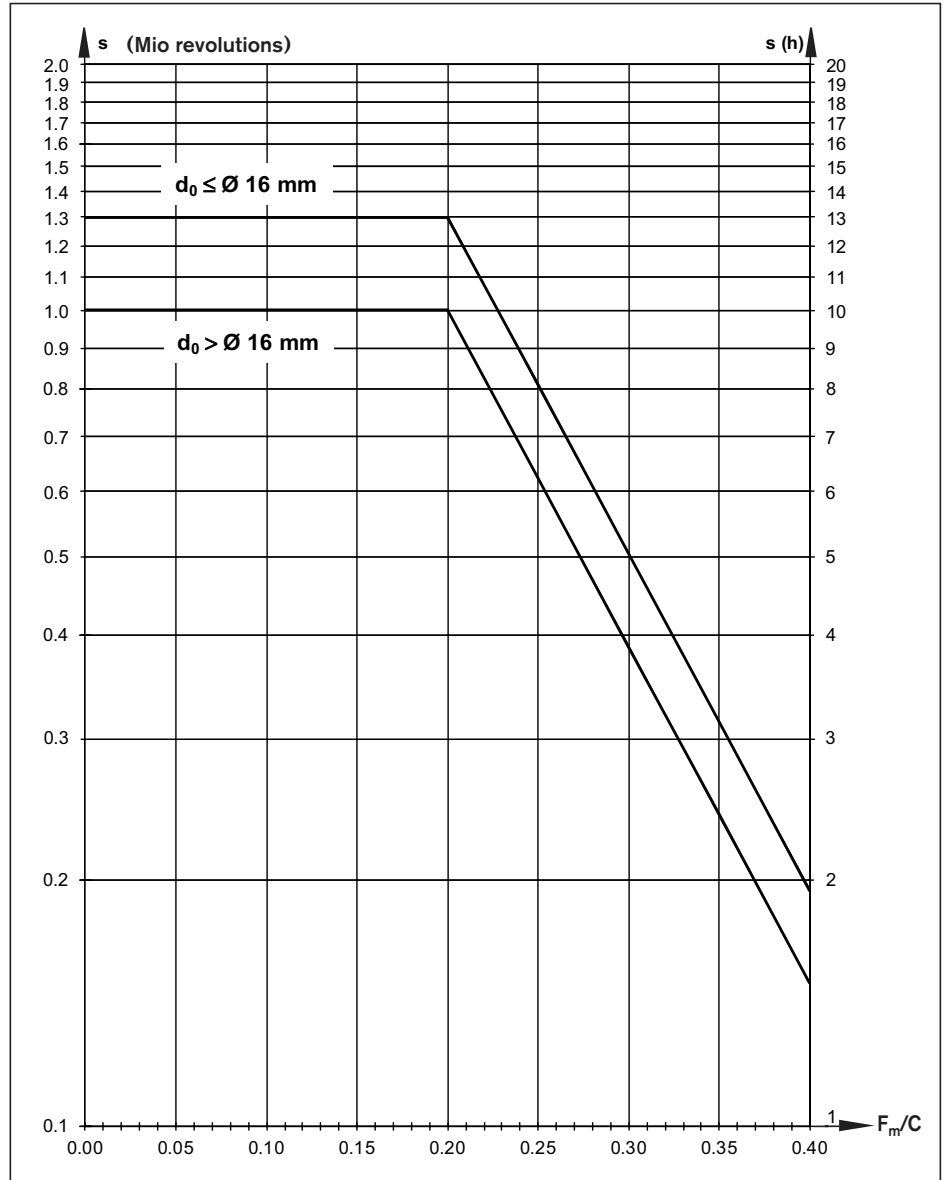

The relubrication interval s is defined either by the number of revolutions in millions or the operating time in h . The value that is reached first defines the lubrication interval.

Conversion of the relubrication interval s from millions of revolutions to kilometers:

$$s \text{ in kilometers} = \frac{s \text{ in millions (of revs)} \cdot \text{lead } P \text{ (mm)}}{10^6}$$

Example:

$$s \text{ in kilometers} = \frac{1.3 \cdot 10^6 \text{ (revs)} \cdot 16 \text{ (mm)}}{10^6} = 20.8 \text{ km}$$

Notes

The load ratio F_m/C is the quotient of the equivalent dynamic axial load F_m and the dynamic load rating C (see "Calculation").

At extreme operating conditions, please consult us as special consideration may be required for the lubrication intervals. These operating conditions include low medium rotary speeds n_m , increased ambient temperatures and high loads $F_m/C > 0.4$.

When using a single-line distributor system, you must ensure that the smallest piston distributor size of 0.03 cm^3 is not fallen short of.

We recommend using piston distributors from SKF. They should be installed as close as possible to the lube ports of the ball screw assembly nut.

Long lines and small line diameters should be avoided, and the lines should be laid on an upward slant.

If other consumers are connected to the single-line centralized lubrication system, the weakest link in the chain determines the lubrication cycle time.

Please also note the general lubrication information on page 149.

Oil lubrication with a single-line piston distributor system

Design example of lubrication a typical two-axis application using central lubrication

X axis

Component or characteristic value	Specifications
Ball screw assembly	FEM-E-S 32x10Rx3.969-5; C = 38000 N; Part no.: R 1512 340 13 (page 34)
Equivalent dynamic axial load	$F_m = 9\,510\text{ N}$
Stroke	1,000 mm
Average speed	$n_m = 1,000\text{ rpm}$
Ambient temperature	10 to 40 °C
Mounting orientation	Horizontal
Lubrication	Single-line distributor system for all axes with Shell Tonna S 220 oil
Exposure	No exposure to media, chips, dust

Design sizes	Design	Sources of information
1. Normal stroke or short stroke	Normal stroke: Stroke > nut length L; 1,000 mm > 77 mm! i.e. normal stroke applies!	For short stroke information, see page 133, for L see page 34
2. Initial lubrication amount	Initial lubrication amount: At the factory with Dynalub 510	See basic lubrication on page page 162
3. Relubrication amount	Relubrication amount: 0.06 cm ³	Relubrication amount from table page 154
4. Mounting orientation	Pay attention to the positioning and traversing instructions for the horizontal mounting orientation!	see "Positioning and traversing instructions" on page 163
5. Piston distributor size	Permitted piston distributor size: 0.03 cm ³	see page 163
6. Number of pulses	Number of pulses = $\frac{0.06\text{ cm}^3}{0.03\text{ cm}^3} = 2$	Number of pulses = $\frac{\text{Relubrication amount}}{\text{Permissible piston distributor size}}$
7. Load ratio	Load ratio = $\frac{9,510\text{ N}}{38,000\text{ N}} = 0.25$	Load ratio = $\frac{F_m}{C}$ F_m and C from specifications
8. Relubrication interval	Relubrication interval: $0.63 \cdot 10^6$ revs or every 6.3 h	From diagram on page 164 with a load ratio of 0.25
9. Effective relubrication interval	Since at $n_m = 1,000\text{ rpm}$ the $0.63 \cdot 10^6$ revs is only reached after 10.5 h, the read-off 6.3 h is effective as the lubrication interval.	n_m from specifications is the effective relubrication interval, see the "Note" on page 162
10. Lube cycle	Lube cycle = $\frac{6.3\text{ h}}{2} = 3.15\text{ h}$	Lube cycle = $\frac{\text{Eff. Relubrication interval}}{\text{Number of pulses}}$

Interim result (X-axis)

In the case of the X-axis, the system must supply the nut of the ball screw assembly with a minimum amount of 0.03 cm³ of Shell Tonna S 220 every two hours.

Y axis

Component or characteristic value	Specifications
Ball screw assembly	FEM-E-B 16x16Rx3-3; C = 11,200 N; Part no.: R 1502 060 63 (page 36)
Equivalent dynamic axial load	$F_m = 1,200 \text{ N}$
Stroke	500 mm
Average speed	$n_m = 1,500 \text{ rpm}$
Ambient temperature	10 to 40 °C
Mounting orientation	Horizontal
Lubrication	Single-line distributor system for all axes with Shell Tonna S 220 oil
Exposure	No exposure to media, chips, dust

Design sizes	Design	Sources of information
1. Normal stroke or short stroke?	Normal stroke: Stroke > nut length L; 500 mm > 61 mm! i.e. normal stroke applies!	For short stroke information, see page 133, for L see page 36
2. Initial lubrication amount	Initial lubrication amount: At the factory with Dynalub 510	See basic lubrication on page page 162
3. Relubrication amount	Relubrication amount: 0.03 cm ³	Relubrication amount from table page 162
4. Mounting orientation	Pay attention to the positioning and traversing instructions for the horizontal mounting orientation!	see "Positioning and traversing instructions" on page 163
5. Piston distributor size	Permitted piston distributor size: 0.03 cm ³	see page 163
6. Number of pulses	Number of pulses = $\frac{0.03 \text{ cm}^3}{0.03 \text{ cm}^3} = 1$	Number of pulses = $\frac{\text{Relubrication amount}}{\text{Permissible piston distributor size}}$
7. Load ratio	Load ratio = $\frac{1,200 \text{ N}}{11,200 \text{ N}} = 0.11$	Load ratio = $\frac{F_m}{C}$ F _m and C from specifications
8. Relubrication interval	Relubrication interval: 1.3 · 10 ⁶ revs or every 13 h	From diagram on page 164 with a load ratio of 0.11
9. Effective relubrication interval	Since at n _m = 1,500 rpm the 1.3 · 10 ⁶ revs is only reached after 14.4 h, the read-off 13 h is effective as the lubrication interval.	n _m from specifications is the effective relubrication interval, see the "Note" on page page 162
10. Lube cycle	Lube cycle = $\frac{13 \text{ h}}{1} = 13 \text{ h}$	Lube cycle = $\frac{\text{Eff. relubrication interval}}{\text{Number of pulses}}$

Interim result (Y-axis)

In the case of the Y-axis, the system must supply the nut of the ball screw assembly with a minimum amount of 0.03 cm³ of Shell Tonna S 220 every 13 hours.

Final result (Two-axis lubrication)

Since the axes in this example are both to be supplied by a single-line distributor system, the X-axis – with its lower (two-hour) lubrication cycle – determines the overall lubrication cycle of the system, i.e. the Y-axis is lubricated every 3.15 hours too.

Lubricants

Dynalub high-performance lubricant for linear motion technology

(Approved in the countries of the EU only; not approved outside of the EU)

Product description of Dynalub 510

Part number	Packaging unit
R3416 037 00	1 x 400 g
R3416 035 00	Hobbock 25 kg

Dynalub 510 is a lithium-based high-performance grease of NLGI grade 2 that has been specially designed for linear motion technology applications. It is characterized by its good water resistance and corrosion protection properties and can be used at temperatures ranging from $-20\text{ }^{\circ}\text{C}$ to $+80\text{ }^{\circ}\text{C}$.

Application area

Under conventional environmental conditions, this ground-fiber, homogeneous grease is ideally suited for the lubrication of linear elements:

- At loads of up to $0.5\text{ }C_{\text{dyn}}$
- Also with short-stroke applications $\geq 1\text{ (mm)}$

Technical data

For additional information, see the "Dynalub 510 safety data sheet"
R310DE 2052 (2004.04)

Chemical composition	Mineral base oil, special lithium soap, active ingredients	
Identification	KP2K-20	DIN 51 825
Appearance	Light brown-beige, ground-fiber	
Service temperature range	$-20\text{ }^{\circ}\text{C}$ to $+80\text{ }^{\circ}\text{C}$	
NLGI grade	2	
Worked penetration	265-295 1/10 mm	DIN ISO 2137
Water resistance	0-60, 1-90	DIN 51 807 T1
Melting point in $^{\circ}\text{C}$	> 165	DIN ISO 2176
Flash point in $^{\circ}\text{C}$	> 200 base oil	DIN ISO 2592
Basic oil viscosity	100 mm^2/s 40 $^{\circ}\text{C}$	DIN 51 562
	10 mm^2/s 100 $^{\circ}\text{C}$	
Flow pressure at $-20\text{ }^{\circ}\text{C}$	< 1,400 hPa	DIN 51 805
EMCOR test	0/0	DIN 51 802
Density at $+25\text{ }^{\circ}\text{C}$	Approx. 0.92 g/cm^3	DIN 51 757
Copper corrosion	2 (24 h/120 $^{\circ}\text{C}$)	DIN 51 811
Four ball tester welding load	> 2,000 N	DIN 51 350 T4
Four ball tester impression diameter	0.93 (400 N, 1 h)	DIN 51 350, part 5
Shelf life in container	2 years	

Product description of Dynalub 520

Part number	Packaging unit
R3416 043 00	1 x 400 g
R3416 042 00	Bucket 5 kg
R0419 090 01	5 ml maintenance kit

Dynalub 520 is a lithium-based high-performance grease of NLGI grade 00 that has been specially designed for linear motion technology applications. It is characterized by its good water resistance and corrosion protection properties and can be used at temperatures ranging from $-20\text{ }^{\circ}\text{C}$ to $+80\text{ }^{\circ}\text{C}$.

Application area

Under conventional environmental conditions, this ground-fiber, homogeneous grease is ideally suited for the lubrication of linear elements in miniature versions and for use in central lubrication systems.

Technical data

For additional information, see the "Dynalub 520 safety data sheet"
R310DE 2053 (2004.04)

Chemical composition	Mineral base oil, special lithium soap, active ingredients	
Identification	KP00K-20	DIN 51 825
Appearance	Light brown-beige, ground-fiber	
Service temperature range	$-20\text{ }^{\circ}\text{C}$ to $+80\text{ }^{\circ}\text{C}$	
NLGI grade	00	
Worked penetration	400-430 1/10 mm	DIN ISO 2137
Water resistance	1-90	DIN 51 807 T1
Melting point in $^{\circ}\text{C}$	> 160	DIN ISO 2176
Flash point in $^{\circ}\text{C}$	> 200 base oil	DIN ISO 2592
Basic oil viscosity	100 mm^2/s 40 $^{\circ}\text{C}$	DIN 51 562
	10 mm^2/s 100 $^{\circ}\text{C}$	
Flow pressure at $-20\text{ }^{\circ}\text{C}$	< 700 hPa	DIN 51 805
EMCOR test	0	DIN 51 802
Density at $+25\text{ }^{\circ}\text{C}$	Approx. 0.92 g/cm^3	DIN 51 757
Copper corrosion	0-1 (24 h/100 $^{\circ}\text{C}$)	DIN 51 811
Four ball tester welding load	1,800 N	DIN 51 350 T4
Four ball tester impression diameter	0.80 (400 N, 1 h)	DIN 51 350 T5
Shelf life in container	2 years	

Calculation

On request, we can perform all calculations to your specifications.

See "Design Calculation Service Form" on page 169

Average speed and average load

Where the operating conditions vary (fluctuating speed and load), the service life must be calculated using the average values F_m and n_m .

- Where the speed fluctuates, the average speed n_m is calculated as follows:

$$n_m = \frac{|n_1| \cdot q_{t1} + |n_2| \cdot q_{t2} + \dots + |n_n| \cdot q_{tn}}{100\%} \quad 1$$

n_1, n_2, \dots, n_n = speeds in phases 1 ... n (rpm)
 n_m = average speed (rpm)
 $q_{t1}, q_{t2}, \dots, q_{tn}$ = discrete time step in phases 1 ... n (%)

- The following applies to the effective equivalent bearing load:

$$|F_n| > 2.8 \cdot F_{pr} \quad F_{eff\ n} = |F_n|$$

$$|F_n| \leq 2.8 \cdot F_{pr} \quad F_{eff\ n} = \left[\frac{|F_n|}{2.8 \cdot F_{pr}} + 1 \right]^{\frac{3}{2}} \cdot F_{pr}$$

C = dynamic load rating (N)
 $F_{eff\ n}$ = effective equivalent axial load during phase n (N)
 F_n = axial load during phase n (N)
 F_{pr} = pre-tensioning force (see tables on pages 148/151) (N)

- Where the load fluctuates and the speed is constant, the equivalent dynamic axial load F_m is calculated as follows:

$$F_m = \sqrt[3]{|F_{eff\ 1}|^3 \cdot \frac{q_{t1}}{100\%} + |F_{eff\ 2}|^3 \cdot \frac{q_{t2}}{100\%} + \dots + |F_{eff\ n}|^3 \cdot \frac{q_{tn}}{100\%}} \quad 2$$

$F_{eff\ 1}, F_{eff\ 2}, \dots, F_{eff\ n}$ = effective equivalent axial load during phases 1 ... n (N)
 F_m = equivalent dynamic axial load (N)
 $q_{t1}, q_{t2}, \dots, q_{tn}$ = discrete time step for $F_{eff\ 1}, \dots, F_{eff\ n}$ (%)

- Where both the load and the speed fluctuate, the equivalent dynamic axial load F_m is calculated as follows:

$$F_m = \sqrt[3]{|F_{eff\ 1}|^3 \cdot \frac{|n_1|}{n_m} \cdot \frac{q_{t1}}{100\%} + |F_{eff\ 2}|^3 \cdot \frac{|n_2|}{n_m} \cdot \frac{q_{t2}}{100\%} + \dots + |F_{eff\ n}|^3 \cdot \frac{|n_n|}{n_m} \cdot \frac{q_{tn}}{100\%}} \quad 3$$

$F_{eff\ 1}, F_{eff\ 2}, \dots, F_{eff\ n}$ = effective equivalent axial load during phases 1 ... n (N)
 F_m = equivalent dynamic axial load (N)
 n_1, n_2, \dots, n_n = speeds in phases 1 ... n (rpm)
 n_m = average speed (rpm)
 $q_{t1}, q_{t2}, \dots, q_{tn}$ = discrete time step for $F_{eff\ 1}, \dots, F_{eff\ n}$ (%)

Nominal service life

Service life in revolutions L

$$L = \left[\frac{f_{ac} \cdot C}{F_m} \right]^3 \cdot 10^6 \quad 4 \Rightarrow C = \frac{F_m}{f_{ac}} \cdot \sqrt[3]{\frac{L}{10^6}} \quad 5 \Rightarrow F_m = \frac{f_{ac} \cdot C}{\sqrt[3]{\frac{L}{10^6}}} \quad 6$$

C = dynamic load rating (N)
 F_m = equivalent dynamic axial load (N)
 L = nominal service life in revolutions (-)
 f_{ac} = Correction factor for tolerance grades (see page 141)

Service life in hours L_h

$$L_h = \frac{L}{n_m \cdot 60} \quad 7$$

L_h = Service life (hrs)
 L = service life in revolutions (-)
 n_m = average speed (rpm)

$$L_{h \text{ machine}} = L_h \cdot \frac{DC_{\text{machine}}}{DC_{\text{BASA}}} \quad 8$$

DC_{machine} = duty cycle of the machine (%)
 DC_{BASA} = duty cycle of the BASA (%)
 $L_{h \text{ machine}}$ = nominal service life of the machine (h)
 L_h = nominal service life of the ball screw assembly (h)

Drive torque and drive power

You must check end machining for the maximum permissible torque

Drive torque M_{ta}

For conversion of rotary motion to linear motion

$$M_{ta} = \frac{F_L \cdot P}{2000 \cdot \pi \cdot \eta} \quad 9$$

$M_{ta} \leq M_p$

F_L = thrust force (N)
 M_p = maximum permissible drive torque (Nm)
 M_{ta} = drive torque (Nm)
 P = lead (mm)
 η = mech. efficiency ($\eta \approx 0.9$) (-)

Transmitted torque M_{te}

for conversion of linear motion into rotary motion:

$$M_{te} = \frac{F_L \cdot P \cdot \eta'}{2000 \cdot \pi} \quad 10$$

$M_{te} \leq M_p$

F_L = thrust force (N)
 M_p = maximum permissible drive torque (Nm)
 M_{te} = transmitted torque (Nm)
 P = lead (mm)
 η' = mech. efficiency ($\eta' \approx 0.8$) (-)

The dynamic drag torque must be taken into account for preloaded nut units.

Drive power P_a

$$P_a = \frac{M_{ta} \cdot n}{9\,550} \quad 11$$

M_{ta} = drive torque (Nm)
 n = speed (rpm)
 P_a = drive power (kW)

⚠ With critical applications, you must pay attention to the information below.

Static load safety factor S_0

You must verify mathematically any structural design involving rolling contact with regard to the static load safety factor.

In this connection, $F_{0 \text{ max}}$ represents the maximum load amplitude that can occur, which can affect the screw drive. It does not matter whether this load is exerted only for a short period. It may represent the peak amplitude of an overall dynamic loading. For design purposes, the data shown in the table applies.

$$S_0 = C_0 / (F_{0 \text{ max}}) \quad 12$$

C_0 = Static load rating (N)
 $F_{0 \text{ max}}$ = Maximum static load (N)
 S_0 = Static load safety factor (-)

Design of the static load safety factor in relation to the operating conditions

Operating conditions	Static load safety factor S_0
Overhead arrangements and applications representing a high hazard potential	≥ 12
High dynamic load when at standstill, contamination.	8 - 12
Normal design of machinery and plant without full knowledge of the load parameters or connection details.	5 - 8
Full knowledge of all the load data. Vibration-free operation is ensured.	3 - 5

If there are health and safety hazards, protection against falling loads must be provided (see the chapter entitled "Arrestor nut")

Calculation

Calculation example service life

Operating conditions

The service life of the machine should be 40,000 operating hours with the BASA operating 60% of the time.

Proposed BASA: 63 x 10

$F_1 = 50\,000\text{ N}$	at	$n_1 = 10\text{ rpm}$	for	$q_1 = 6\%$	of the duty cycle
$F_2 = 25\,000\text{ N}$	at	$n_2 = 30\text{ rpm}$	for	$q_2 = 22\%$	of the duty cycle
$F_3 = 8\,000\text{ N}$	at	$n_3 = 100\text{ rpm}$	for	$q_3 = 47\%$	of the duty cycle
$F_4 = 2\,000\text{ N}$	at	$n_4 = 1000\text{ rpm}$	for	$q_4 = 25\%$	of the duty cycle
					100%

Calculation procedure

Average torque n_m

$$n_m = \frac{6}{100} \cdot |10| + \frac{22}{100} \cdot |30| + \frac{47}{100} \cdot |100| + \frac{25}{100} \cdot |1000| \quad 1$$

$$n_m = 304\text{ rpm}$$

Equivalent dynamic axial load F_m for variable load and variable speed

$$F_m = \sqrt[3]{|50000|^3 \cdot \frac{|10|}{304} \cdot \frac{6}{100} + |25000|^3 \cdot \frac{|30|}{304} \cdot \frac{22}{100} + |8000|^3 \cdot \frac{|100|}{304} \cdot \frac{47}{100} + |2000|^3 \cdot \frac{|1000|}{304} \cdot \frac{25}{100}} \quad 3$$

$$F_m = 8\,757\text{ N}$$

Required service life L
(revolutions)

The service life L can be calculated by transposing formulas 7 and 8:

$$L = L_h \cdot n_m \cdot 60$$

$$L_h = L_{h\text{ machine}} \cdot \frac{DC_{\text{BASA}}}{DC_{\text{machine}}}$$

$$L_h = 40\,000 \cdot \frac{60}{100} = 24\,000\text{ h}$$

$$L = 24\,000 \cdot 304 \cdot 60$$

$$L = 437\,760\,000\text{ revolutions}$$

Basic dynamic load rating C

$$C = 8\,757 \cdot \sqrt[3]{\frac{437\,760\,000}{10^6}} \quad 5 \quad C \approx 66\,492\text{ N}$$

Result and selection

Now a selection can be made from the dimension tables:

e.g. ball screw assembly,
size 63 x 10 R x 6-6, with preloaded
FEM-E-S single flange nut,
dyn. load capacity $C = 106,600\text{ N}$,
part no. R1512 640 13,
with screw tolerance grade 7.

Attention:
Take into account the dynamic load rating
of the screw end bearing used!

⚠ Take into account correction factor f_{ac} of the tolerance grade! See page 141.

Cross-check

Now the following can be selected from the product tables:

Size 63 x 10 R x 6-6

Backlash (C0)

**Preload
(preload class C3)**

FEM-E-S, with standard backlash

Load rating $C_{dyn} = 106,560$ N
correction factor $f_{ac} = 0.9$

Cross-check

Service life of the selected ball screw drive in revolutions

$$L = \left[\frac{0.9 \cdot 106\,560}{8\,757} \right]^3 \cdot 10^6$$

$$L \approx 1314 \cdot 10^6 \text{ revolutions}$$

Service life in hours L_h

$$L_h = \frac{1\,314 \cdot 10^6}{304 \cdot 60}$$

$$L_h \approx 72,039 \text{ hours}$$

FEM-E-S, with preload class C3

Load rating $C_{dyn} = 106,560$ N
Correction factor $f_{ac} = 0.9$
Pre-tensioning force = 4400 N

Cross-check

The following applies to the effective equivalent bearing load:

$$\begin{aligned} |F_n| > 2.8 \cdot F_{pr} & \quad F_{eff\ n} = |F_n| \\ |F_n| \leq 2.8 \cdot F_{pr} & \quad F_{eff\ n} = \left[\frac{|F_n|}{2.8 \cdot F_{pr}} + 1 \right]^{\frac{3}{2}} \cdot F_{pr} \end{aligned}$$

C = dynamic load rating (N)
 $F_{eff\ n}$ = effective equivalent axial load during phase n (N)
 F_n = axial load during phase n (N)
 F_{pr} = pre-tensioning force (see tables on pages 148/151) (N)

$$2.8 \times F_{pr} = 2.8 \times 4\,440 \text{ N} = 12\,432 \text{ N}$$

$$- F_1 = 50\,000 \text{ N} > 12\,432 \text{ N} \Rightarrow F_{eff1} = 50\,000 \text{ N}$$

$$- F_2 = 25\,000 \text{ N} > 12\,432 \text{ N} \Rightarrow F_{eff2} = 25\,000 \text{ N}$$

$$- F_3 = 8\,000 \text{ N} < 12\,432 \text{ N} \Rightarrow F_{eff3} = \left[\frac{8\,000}{12\,432} + 1 \right]^{1.5} \cdot 4\,440 \text{ N} = 9\,355 \text{ N}$$

$$- F_4 = 2\,000 \text{ N} < 12\,432 \text{ N} \Rightarrow F_{eff4} = \left[\frac{2\,000}{12\,432} + 1 \right]^{1.5} \cdot 4\,440 \text{ N} = 5\,553 \text{ N}$$

$$F_m = \sqrt[3]{\left[50000 \right]^3 \cdot \frac{10}{304} \cdot \frac{6}{100} + \left[25000 \right]^3 \cdot \frac{30}{304} \cdot \frac{22}{100} + \left[9355 \right]^3 \cdot \frac{100}{304} \cdot \frac{47}{100} + \left[5553 \right]^3 \cdot \frac{1000}{304} \cdot \frac{25}{100}}$$

$$F_m = 9\,485 \text{ N}$$

$$L = \left[\frac{0.9 \cdot 106\,560}{9\,485} \right]^3 \cdot 10^6 = 1034 \cdot 10^6 \text{ revolutions}$$

$$L_h = \frac{1\,034 \cdot 10^6}{304 \cdot 60} = 56,689 \text{ hours}$$

The service life of both BASAs (with standard backlash C0/with preload class C3) exceeds the required service life of $40,000 \times 60\% = 24,000$ hours. This means that it is possible to choose a smaller BASA, subject to a review of it being undertaken.

Critical speed n_{cr}

The critical speed n_{cr} depends on the diameter of the screw, the type of end fixity, and the free length l_{cr} . No allowance must be

made for guidance by a nut with backlash. The operating speed should not be more than 80% of the critical speed.

The characteristic speed and the max. permissible linear speed must be taken into account, see "Technical notes" on page 132.

Example

Screw diameter = 63 mm
Length l_{cr} = 2.4 m
End fixity II (fixed bearing - floating bearing)

According to the graph, the critical speed is 1850 rpm.
The permissible operating speed is 1850 rpm x 0.8 = 1480 rpm.

The maximum operating speed in our calculation example of $n_4 = 1000$ rpm is therefore below the permissible operating speed.

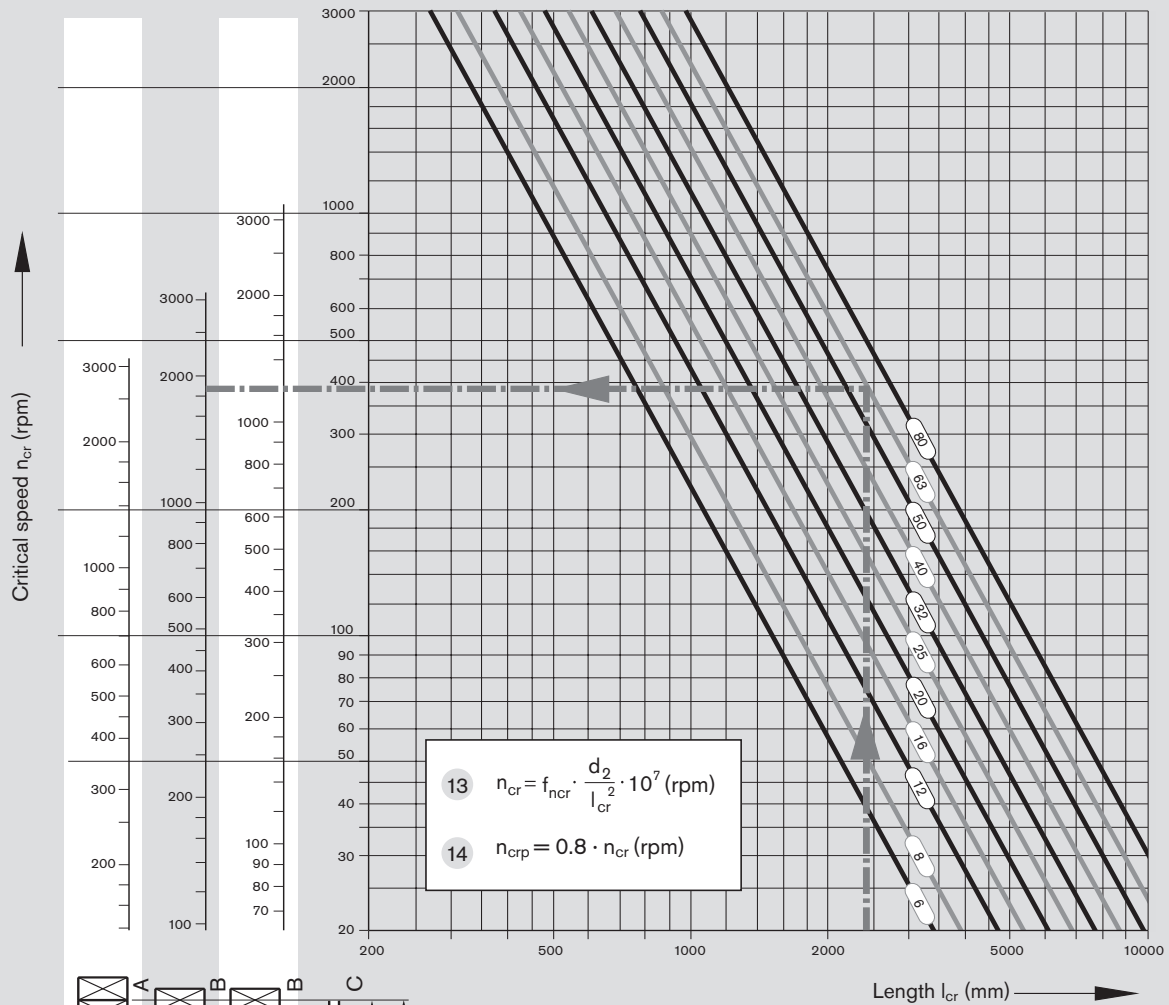

End fixity:

- A = fixed bearing
- B = floating bearing
- C = without bearing

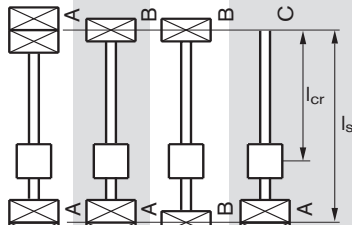

End fixity	I	II	III	IV
f_{ncr} - value	27.4	18.9	12.1	4.3

- n_{cr} = Critical speed (rpm)
- n_{crp} = Permissible operating speed (rpm)
- f_{ncr} = Coefficient determined by bearing
- d_2 = Root diameter of screw (see dimension tables) (mm)
- l_{cr} = Critical length for preloaded nut systems (mm)
- l_s = Bearing - bearing distance (mm)

For non-preloaded nut systems $l_{cr} = l_s$
For screw ends Form 31, the end fixity can be assumed to be "fixed".

Attention: End fixity IV (fixed-floating) – only recommended for short overall lengths if installed horizontally. For longer overall lengths, the floating end must be supported. Please contact our specialist department if you have any questions.

Permissible axial load on screw F_c (buckling load)

The permissible axial load on the screw F_c depends on the diameter of the screw, the

type of end fixity, and the effective unsupported length l_c .

A safety factor of $s \geq 2$ should be taken into account for axial loading.

Example

- Screw diameter = 63 mm,
- Lead = 10 mm,
- Length l_c = 2.4 m
- End fixity IV (fixed bearing - floating bearing)

According to the graph, the theoretically permissible axial load is 360 kN. Applying the safety factor 2 yields a permissible axial load on the screw in operation of $360 \text{ kN} : 2 = 180 \text{ kN}$.

This therefore lies above the maximum operating load of $F_1 = 50 \text{ kN}$ used in our calculation example.

15 $F_c = f_{F_c} \cdot \frac{d_2^4}{l_c^2} \cdot 10^4 \text{ (N)}$

16 $F_{cp} = \frac{F_c}{2} \text{ (N)}$

- F_c = Theoretically permissible axial load on screw (N)
- F_{cp} = Permissible axial load on screw during operation (N)
- f_{F_c} = Corrector value determined by bearing
- d_2 = Root diameter of screw, see dimension tables (mm)
- l_c = unsupported thread length (mm)

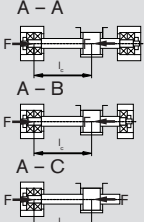
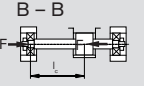
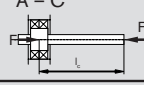
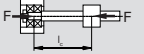
End fixity:	coefficient f_{F_c}	
	nut fixed	nut floating
 End fixity I 39.7		End fixity IV 20.3
 End fixity II 20.3		End fixity V 9.9
 End fixity III 2.5		
 End fixity VI 2.5		

- End fixity:**
- A = fixed bearing
 - B = floating bearing
 - C = without bearing

f_{F_c} value	End fixity
2.5	III / VI
9.9	V
20.3	II / IV
39.7	I

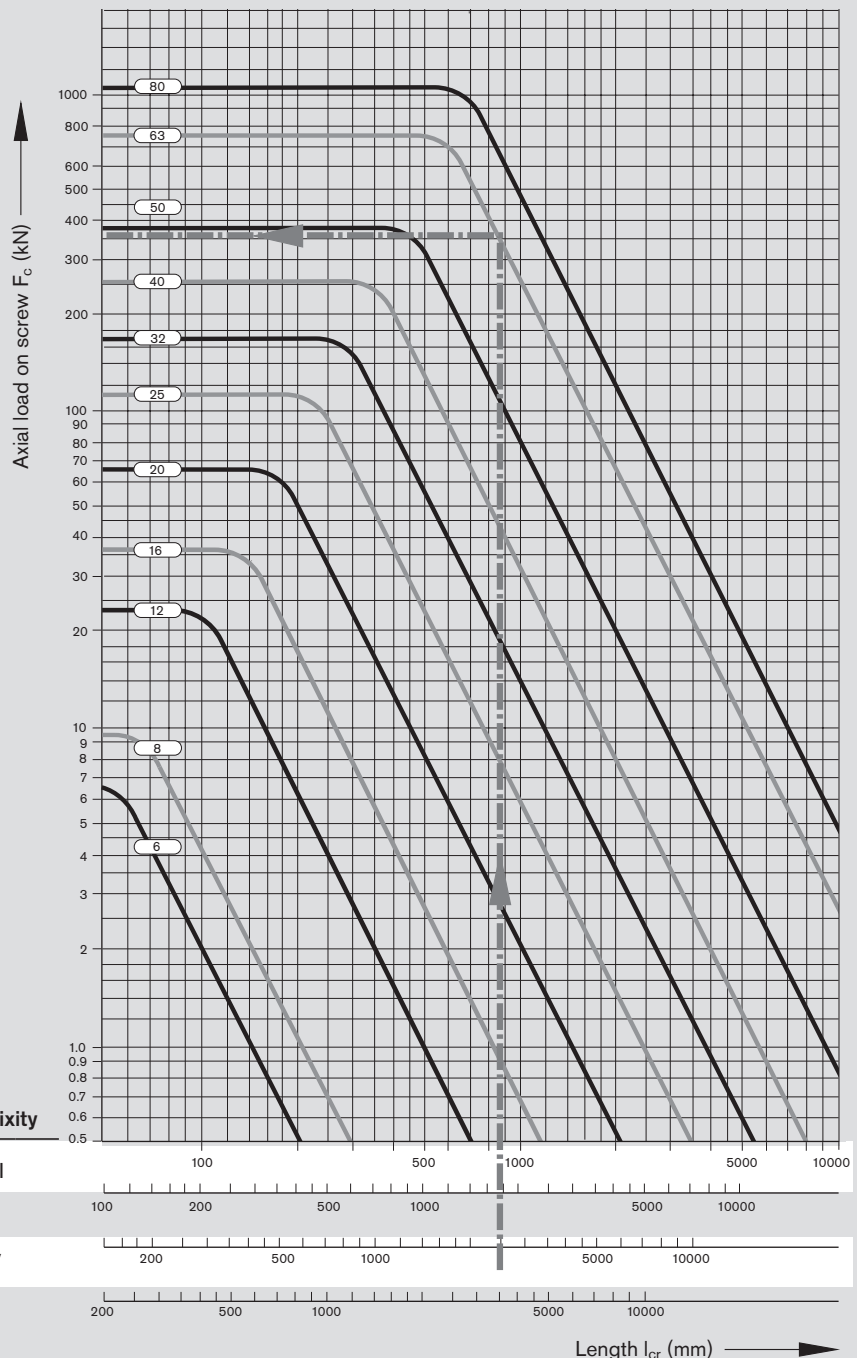

Notes on buckling

The effective buckling length l_c of the screw is the maximum unsupported screw length in the direction of the force's flow between the nut unit and the fixed bearing (center-to-center distance) or between the nut unit and the screw end.

For buckling load calculations, the nut is taken into consideration as a bearing.

For "nut fixed," the following conditions must be met:

- zero-backlash nut,
- rigid attachment of the nut to the linear guide,
- the nut unit is not subjected to moment loads, i.e. a linear guide absorbs any arising moments,
- no distortive stresses due to external factors (for example, temperature).

In linear motion systems from Bosch Rexroth, the nut can be considered to be a fixed bearing.

If one or more of the conditions for "nut fixed" are not met, the appropriate coefficients for "nut floating" must be used instead.

Case III occurs in applications with driven nuts, for example, when the nut is stationary and the screw rotates. The nut can then be regarded as a fixed bearing.

Case VI arises only when the nut unit is not supported by any linear guide.

Design of drive unit FAR-B-S

Fundamental advantages of systems with driven nuts

Moment of inertia

In the case of long screws, the screw does not have to be rotated in the acceleration phase, only the nut. The mass moment of inertia of the screw is not therefore critical. The moment of inertia of the nut is comparatively low and it is no longer dependent on the required stroke.

Dynamics

The intricate end bearing designs required for high dynamics, for example, fixed bearing on both ends with angular-contact ball bearings, are no longer necessary.

Screw extenders

Since the screw is stationary, relatively little effort is needed to stretch the screw:

- Increase in permissible axial loading (buckling load); not limited by end bearings
- Compensation of responses to temperature changes
- Increase in overall rigidity

Liquid cooling

- Improved cooling can easily be provided using a hollow-bored screw:
- the stationary screw can be cooled with comparatively little effort.
- Controlled cooling virtually eliminates changes in length due to temperature fluctuations.

Design and manufacturing tolerances

The use of nuts with a high level of axial and radial runout precision minimizes the induced screw vibration.

All functional components are supplied from a single source. In-house designs are no longer needed.

Critical speed

$$n_{cr} = f_{ncr} \cdot \frac{d_2}{l_{cr}} \cdot 10^7 \text{ (min}^{-1}\text{)}$$

$$n_{crp} = 0.8 \cdot n_{cr} \text{ (rpm)}$$

- n_{cr} = Critical speed (rpm)
- n_{crp} = Perm. operating speed (rpm)
- f_{ncr} = Coefficient determined by the bearing
- d_2 = For root diameter of screw, see dimension tables (mm)
- l_{cr} = Critical length for preloaded nut systems (mm)

Critical speed with driven screw:
 In the case of driven, rotating screws, there is a critical speed that is dependent on the different end fixities:

- I Fixed-fixed,
- II Fixed-floating,
- III Floating-floating,
- IV Fixed-free.

In the case of systems with a driven screw, the bending-critical speed frequently represents a limitation on speed that can be reached.

The rotating screw itself generates vibrations in the system due to the deflection in the horizontal fixity or even due to screw imbalance. Depending on the free screw length and the speed, resonance and very high amplitudes can result that may destroy the system.

At the design stage, a safety distance of 20% to the critical speed is generally maintained.

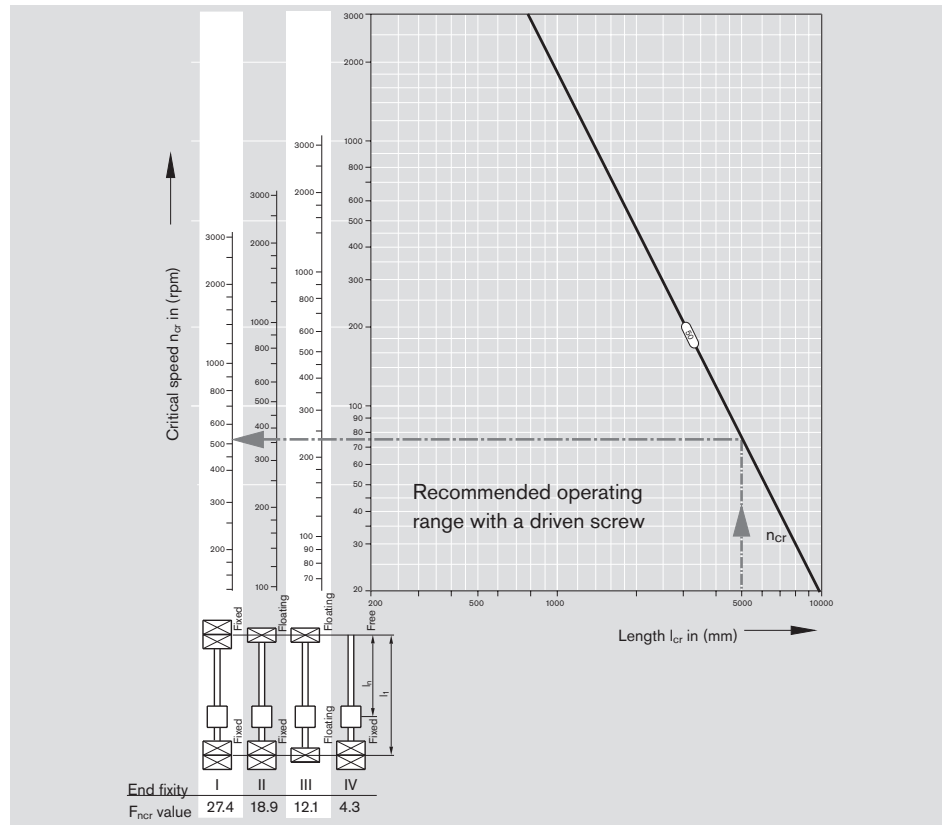

Critical speed with driven nut:

In the case of systems with a driven nut and a stationary screw, self-excitation of the screw is omitted completely with a suitable design.

The only other things that excite vibrations are the manufacturing precision of the rotating nut or of the machine's construction. Since FAR-B-S drive units only use nuts that have been manufactured with a high degree of axial and radial run-out accuracy, this means that it is possible to rule out any negative effect on the overall system.

This means that the bending-critical speed no longer represents a limitation.

The maximum speed of the bearings that are used and, to a lesser extent, the high maximum permissible rotary speed ($d_0 \times n$ Wert) of the nut that is used, are still a limitation.

Note:
 Applies to fixed-fixed bearing only

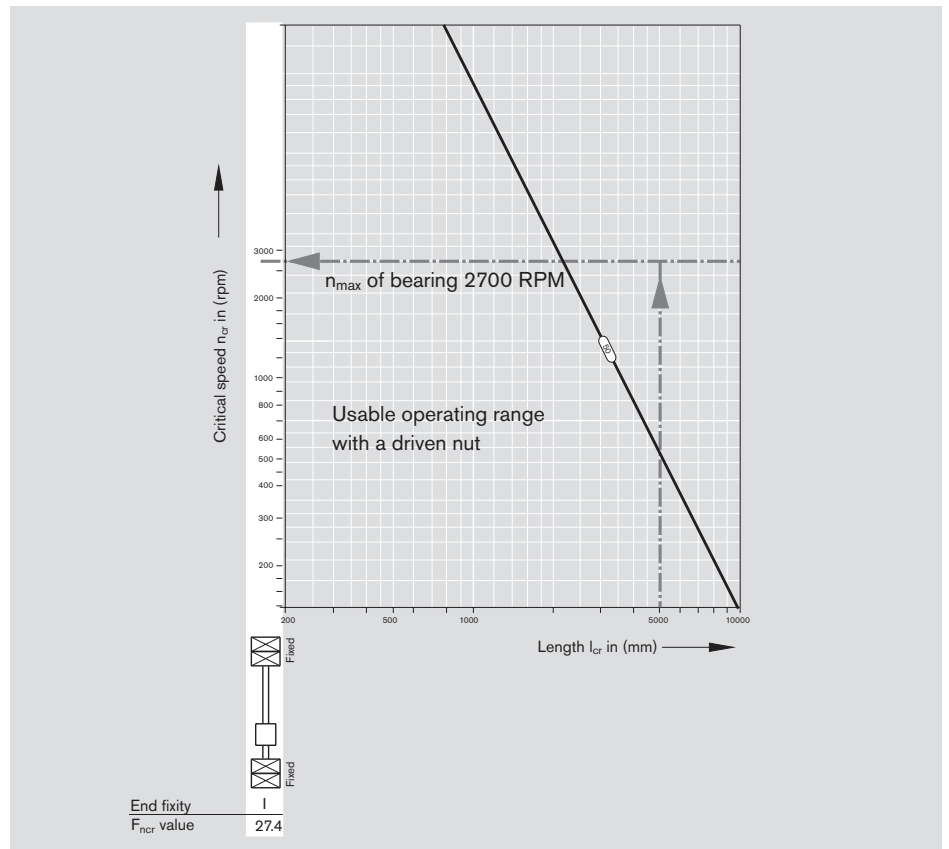

Design of drive unit FAR-B-S

Permissible travel speed in dependence on the nut position

Permissible travel speed with a driven nut
End fixity I fixed-fixed bearing
End fixity II fixed-floating bearing

Parameters:

- Screw length
- Screw diameter
- Lead
- End fixity
- Stretching force, negligible
- Max. speed of bearing
- $D \times n$ value of nut

The adjacent diagrams make clear the benefits of a driven nut compared to a "classical ball screw assembly" with a driven screw using size 50 x 40R x 6.5 as an example.

In the case of the driven screw (diagram at the top), the maximum speed with a favorable nut position in the center of the screw is about 60 m/min. However, this speed is only achieved in one position of the stroke. In the case of a non-central nut position, however, it is only possible to achieve about 20 m/min, since the necessary support for the screw is missing. This means that the potential for a high characteristic speed of the nut ($d \times n$ value) cannot be achieved in practice.

Driven nut

With the driven nut (diagram at the bottom for end fixity I "fixed-fixed"), however, the permissible travel speed of the driven nut is 108 m/min regardless of the nut position across the entire stroke.

In the case of end fixity II "fixed-floating", the floating bearing (axial displacement possible) can be designed such that it is possible to achieve a tangential gradient of the bending line (bending angle at journal area = 0).

In this case, you can also consider a floating bearing end like this as being a fixed bearing for the calculation.

■ Improved performance with driven nut

- - - Driven screw

Driven screw

Max. permissible travel speed in dependence on the nut position size 50x40Rx6.5 fixed-fixed bearing on driven screw

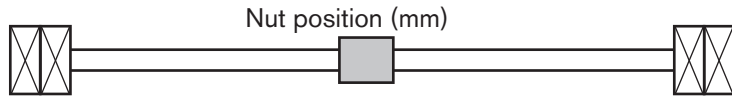
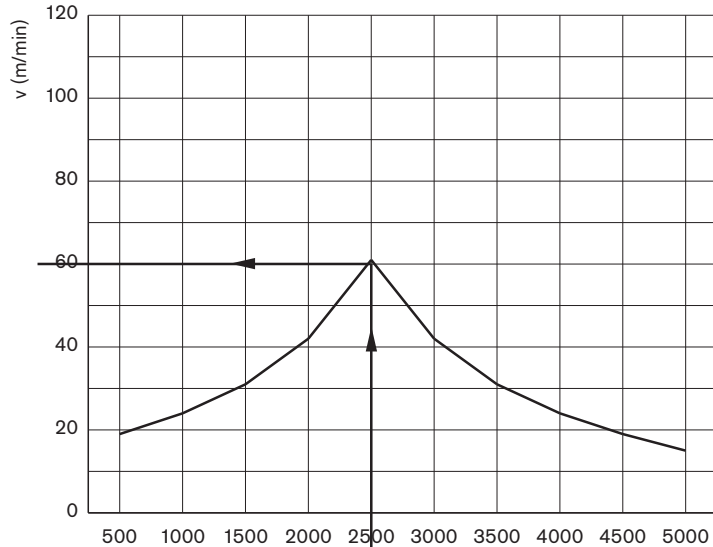

Driven nut

Max. permissible linear speed Size 50x40Rx6.5 with fixed-fixed bearing with driven nut

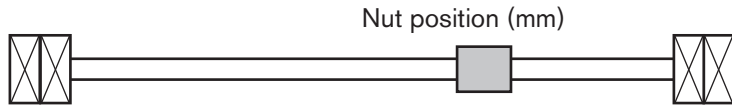
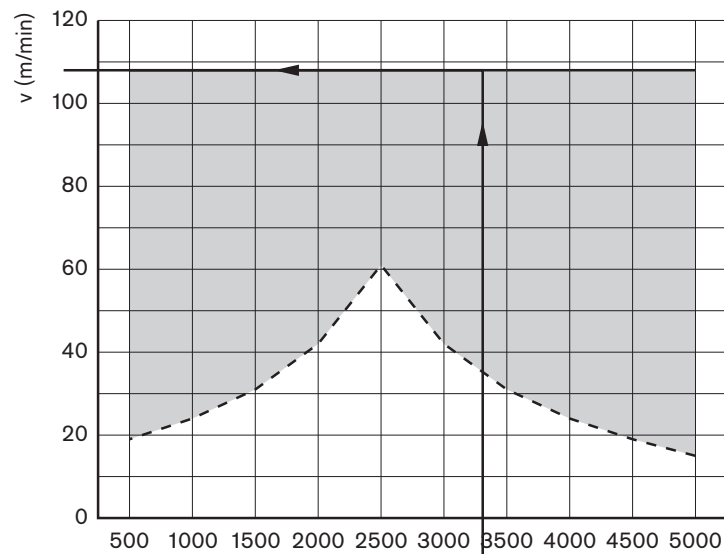

For the permissible RPM and travel speeds of FAR-B-S drive units, refer to the table below:

End fixity I fixed-fixed bearing and end fixity II fixed-floating bearing

FAR-B-S size d ₀ x P x D _w - i	Speed n _{max} (rpm)	Speed v _{max} FAR (m/min)
32 x 10R x 3.969 - 5	3,000	30
32 x 20R x 3.969 - 3	3,000	60
32 x 32R x 3.969 - 3	3,000	96
40 x 10R x 6 - 5	2,800	28
40 x 20R x 6 - 3	2,800	56
40 x 40R x 6 - 3	2,800	112
50 x 10R x 6 - 6	2,700	27
50 x 20R x 6.5 - 5	2,700	54
50 x 40R x 6.5 - 3	2,700	108
63 x 10R x 6 - 6	2,300	23
63 x 20R x 6.5 - 5	2,300	46
63 x 40R x 6.5 - 3	2,300	92

Conversion of rotational speed to velocity

$$v_{\max} = \frac{n_{\max} \cdot P}{1000}$$

v_{max} = velocity (m/min)
P = lead (mm)
n_{max} = rotational speed (RPM)

End fixity III floating-floating bearing

This type of end fixity is virtually never used.

Critical speed with rotating nut and screw clamping end fixity IV fixed-free bearing

In the case of “fixed-free” systems with a driven nut, it is only possible to design the screw for short strokes. To quote an extreme case as an example, the system mass of the 50 x 40 screw with a length of 5,000 mm and horizontal mounting would lead to extreme static sagging of about 180 mm. You must take appropriate design measures to ensure that considerably lower sagging and the forces on the nut resulting from this can be avoided,

In this case, it is also possible with FAR-B-S to consider as a limitation the critical speed at an unfavorable nut position on the tensile restraint (see the diagram on the right in the middle). The maximum theoretical value that can be read-off is 28 m/min and it cannot be used due to the deflection. This means that for practical applications, you must introduce a screw length limitation.

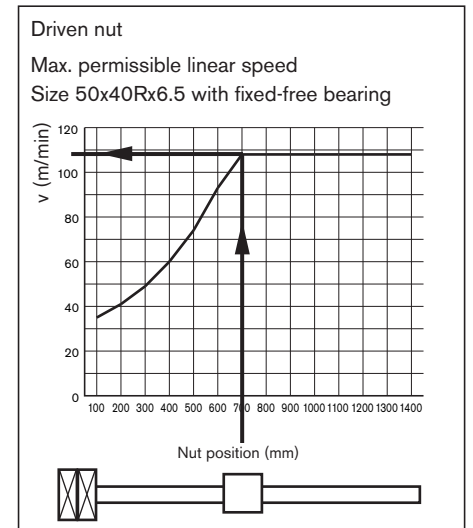
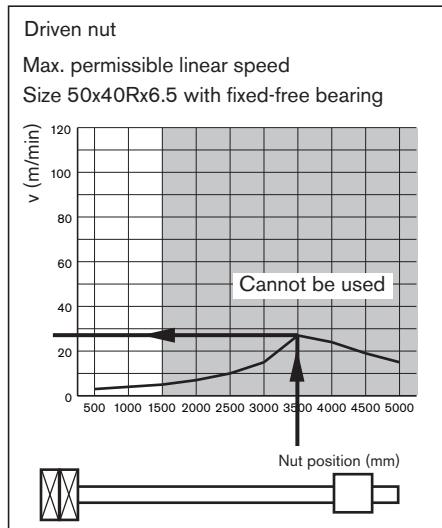

In the example diagram on the right, with the recommended maximum length of screw L_{thread max}, a speed of 108 m/min is achieved at a nut position of 700 mm.

BASA size	Recommended maximum length (mm) L _{thread max}
32	1,000
40	1,200
50	1,400
63	1,600

Design of drive unit FAR-B-S

Permissible torques in dependence on the nut position

The influencing variables below limit the permissible drive torque with the driven nut

- Screw length
- Screw diameter
- End fixity
- Stretching force
- Geometry of the screw end
- Load direction; in an unfavorable case, a compressive force on the longer screw section (buckling load)

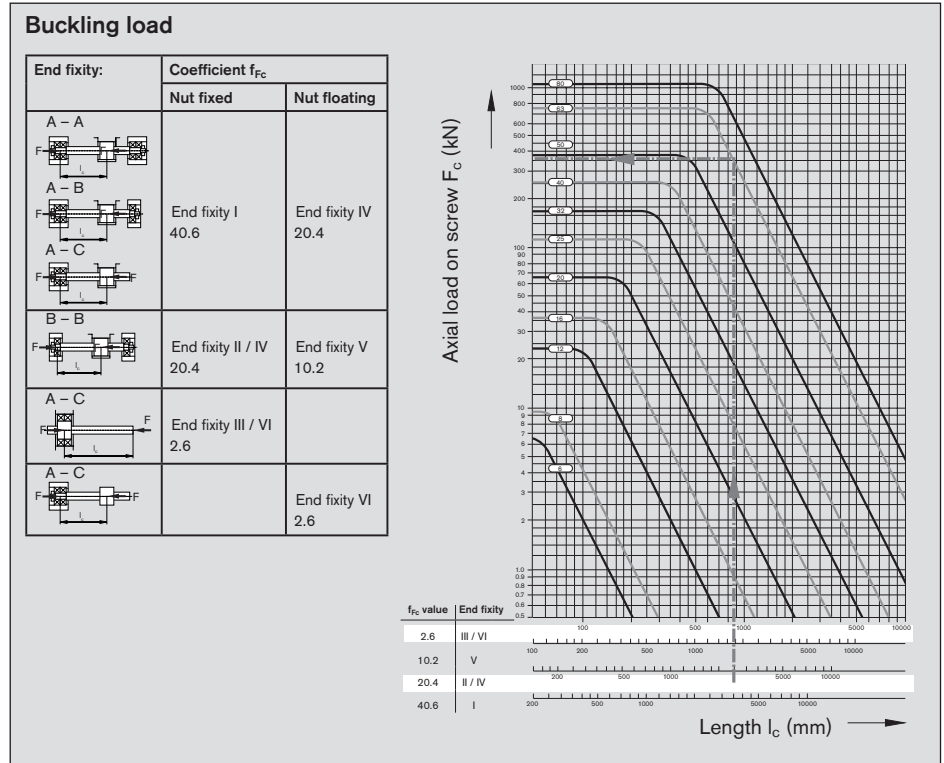

The length and diameter of the screw and its end fixity are taken into account by the Euler buckling case.

This yields the permissible axial load on the screw (see the diagram above). In practice, the adjacent formulas are used for calculation.

$$F_c = f_{Fc} \frac{d_2^4}{l_k^2} \cdot 10^4 \text{ (N)}$$

$$F_{cp} = \frac{F_k}{2} \text{ (N)}$$

$$F_L \leq F_{cp}$$

F_c = Theoretically permissible axial load on screw (N)

F_{cp} = Permissible axial load on screw during operation (N)

f_{Fc} = Corrector value determined by bearing

d_2 = For root diameter of screw, see dimension tables (mm)

l_c = unsupported thread length (mm)

F_L = operating load of the customer (N)

F_{st} = stretching force of the screw (N)

With a stretched screw, the following applies:

$$F_{cp} = \frac{F_c}{2} + F_{st}$$

Due to an increase in temperature, the stretching force may be reduced. You must take this effect into account when calculating F_{kperm} .

The drive torque that is necessary for the operating load results from the following formula:

$$M_{ta} = \frac{F_L \cdot P}{2000 \cdot \pi \cdot \eta}$$

M_{ta} = drive torque on the nut (Nm)

F = operating load (N)

P = lead (mm)

η = mechanical efficiency (approx. 0.9)

The dynamic drag torque must be taken into account for preloaded nut units.

$$M_{ta} \leq M_P$$

M_P = permissible torque at the screw journal (Nm)

Recommended maximum torque with the geometry of screw end 51

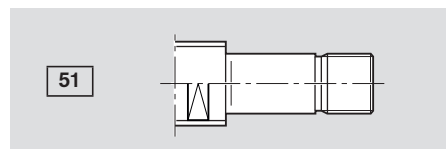

BASA size	M_{Sperm} (Nm)
32	< 40
40	< 150
50	< 180
63	< 190

Typical applications

End fixity I fixed-fixed:

Parameters:

- Screw length; two cases
- Screw diameter
- End fixity in this case, fixed-fixed:
- Stretching force ignored (see the next page)
- Geometry of screw end Form 51 on two sides
- Load direction in an unfavorable case, a compressive force on the longer screw section

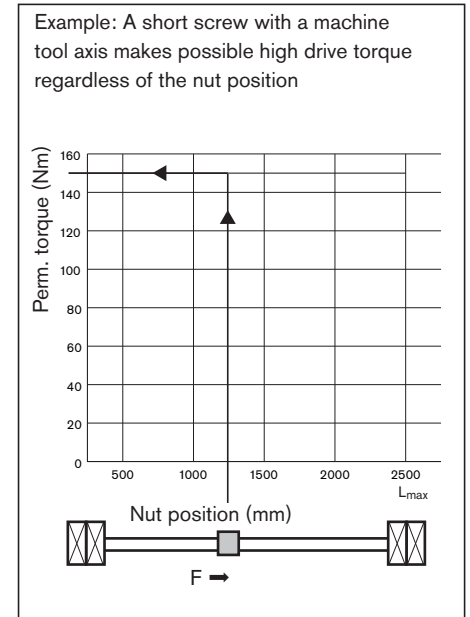
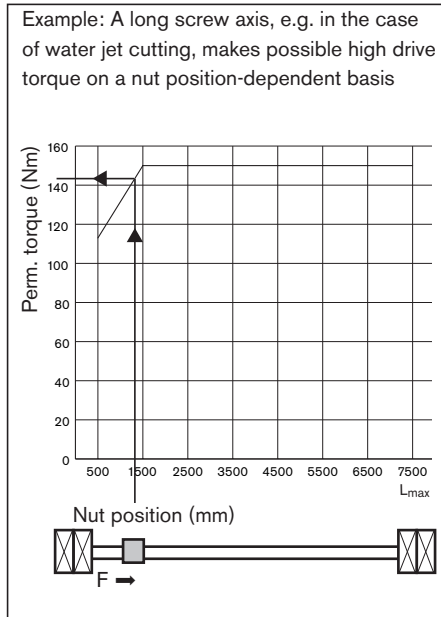

End fixity II fixed-floating:

Stretching is not possible.

End fixity III floating-floating

This type of end fixity is virtually never used.

End fixity IV fixed-free

Parameters:

- Screw length
- Screw diameter
- End fixity, here fixed-free
- Stretching force, none
- Geometry of screw end Form 51 on one side
- Compressive load toward fixed bearing

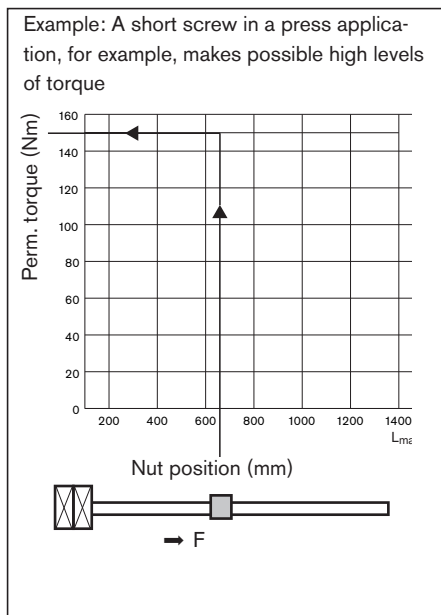

Design of drive unit FAR-B-S

Stretching screws

Basic principles

To be able to exploit the efficiency of a system with a driven nut to the full, it is advisable to use the type of end fixity with fixing of the screw on two sides (fixed-fixed). Stretching of the screw has the following positive effect on the overall system:

- Compensation of temperature effects to avoid compressive loads in the screw, which reduces the risk of buckling

The change in length and the tensile stress that results due to stretching must be kept to a range that is acceptable for the overall system. Otherwise, elastic deformation can lead to impermissible lead deviations between the nut and the screw, which can negatively impact the service life.

In the case of convection cooling of the screw, stretching can maintain a maximum temperature difference of about 10 °C. With long, composite screws, temperature compensation of 5 °C is sensible. Water cooling of the screw is necessary at higher temperature differences.

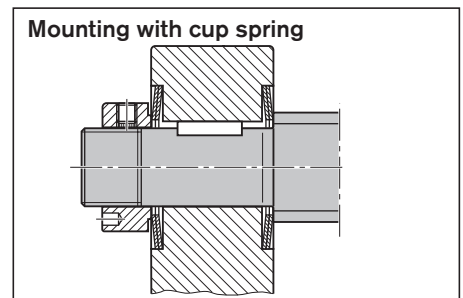
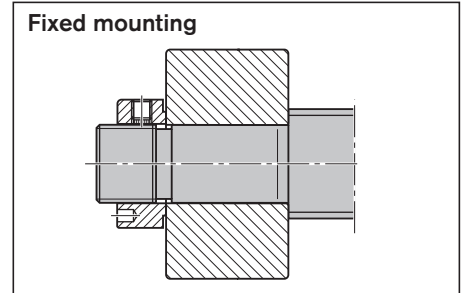

Linear expansion

Calculation of the linear expansion of a screw in operation with a temperature increase.

$$\Delta L = L_{\text{thr}} \cdot \alpha_L \cdot (\vartheta_s - \vartheta_r)$$

Where $\alpha_L = 0.0000115$

ΔL = linear expansion (mm)
 L_{thr} = thread length (mm)
 α_L = linear expansion coefficient (1/K)
 ϑ_s = Screw temperature in operation (K)
 ϑ_r = room temperature (K)

Stretching force

Calculation of the stretching force that is needed for compensating the linear expansion.

$$F_{\text{st}} = \frac{\Delta L \cdot E \cdot \frac{\pi}{4} \cdot d_{\text{ap}}^2}{L_{\text{thr}}}$$

F_{st} = stretching force (N)
 d_{ap} = approximation diameter (mm)
 E = Young's modulus (N/mm²)

$$d_{\text{ap}} = \frac{d_0 + d_2}{2}$$

d_0 = nominal diameter (mm)
 d_2 = screw core diameter (mm)

Compressive stress

The compressive stress in the screw that occurs in the case of fixed mounting on two sides is calculated as shown.

$$\sigma_c = E \cdot (\vartheta_s - \vartheta_r) \cdot \alpha_L$$

σ_c = compressive stress due to increased temperature (N/mm²)

Where $E = 210,000 \text{ N/mm}^2$

Tensile stress

For operation, the tensile stress in the screw due to stretching must be greater than the compressive force due to temperature. At the same time, the permissible tensile stress must not be exceeded.

Tensile stress due to stretching that is generated in the screw

$$\sigma_t = \frac{F_{st}}{\frac{\pi}{4} \cdot d_{ap}^2}$$

σ_t = tensile stress (N/mm²)

$$\sigma_t < \sigma_p$$

The maximum permissible tension
 $\sigma_p = 70 \text{ N/mm}^2$

Permissible change in length

Stretching results in a change of length of the screw, which causes a change in the geometry of the screw and the raceway geometry. To avoid negative effects on the service life of the ball screw assembly, you must check it.

$$\Delta L_{perm} = L_{thr} \cdot 0.0001$$

ΔL_{perm} = perm. linear expansion (mm)
 L_{thr} = thread length (mm)

$$\Delta L \leq \Delta L_{perm}$$

Design notes, installation

Bearing design

For customer machining, please consider the design notes for screw ends and housings.

For Rexroth screw end designs, see "End Machining Details."

Rexroth delivers complete drive systems including bearing units without housing. Calculations are performed with the formulas used in the antifriction bearing industry.

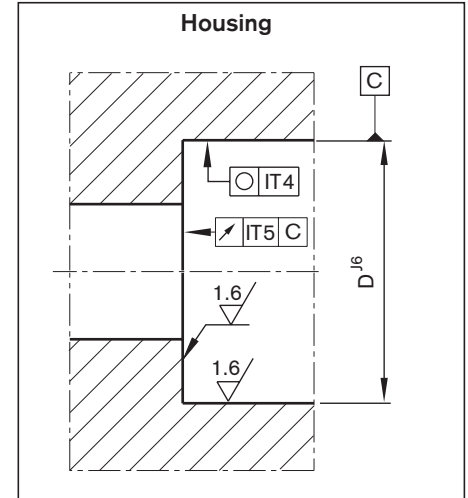
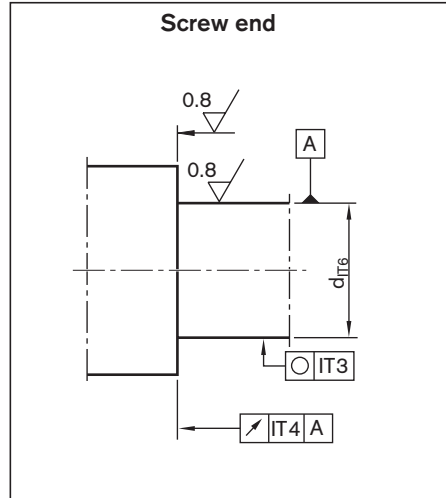

Mounting

Angular-contact thrust ball bearings LGF and LGN

When mounting the angular-contact thrust ball bearings LGF and LGN, ensure that the mounting forces are exerted only on the bearing rings. Never apply mounting forces via the anti-friction bearing elements or the seal rings! The two sections of the inner raceway may not be separated during assembly or disassembly for any reason!

Tighten the mounting screws for screw-down or flange-mounted bearings in crosswise sequence. The mounting screws may be subjected only to tension amounting to a maximum of 70% of their yielding point.

The screw-down (LGF) bearings have a groove on the cylindrical surface of the outer raceway for disassembly. The individual bearings of the bearing pair series LGF-C... and LGN-C... are marked on the cylindrical surfaces of the outer raceways (see figure). The markings reveal the bearing sequence. The sealing rings should face outwards after proper mounting.

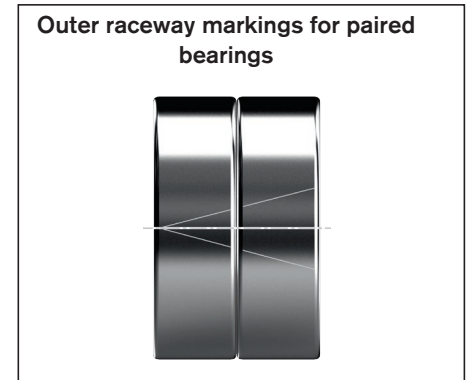

Slotted nut NMA, NMZ

The bearings are preloaded by tightening the nuts.

In order to prevent settling phenomena, we recommend first tightening the slotted nut by twice the value of the tightening torque M_A and then easing the load. Only then should the slotted nut be retightened to the specified tightening torque M_A .

The two set screws are then alternately tightened using a hexagon socket wrench.

The components are disassembled in the reverse order, i.e. the set screws have to be removed before the slotted nut.

The slotted nuts can be used several times when properly assembled and disassembled by competent personnel. The inner raceways of the bearings are dimensioned in such a way as to achieve a defined bearing preload sufficient for most applications when the slotted nut is tightened (M_A in accordance with dimension table).

Design Note

For counter holding the tightening torque M_A of the slotted nut we recommend a wrench flat on the spindle or a hexagon socket on the end face of the spindle.

Mounting the housing

Housing mounting SEB

Tighten the fastening screws of the pillow-block bearings in a crosswise sequence. Refer to the table for the maximum tightening torque. The threaded ring fixes the complete bearing in the housing. Use threadlocking adhesive when assembling the threaded ring.

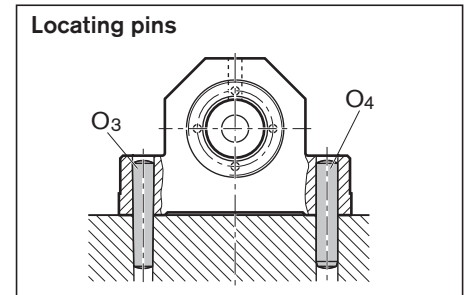
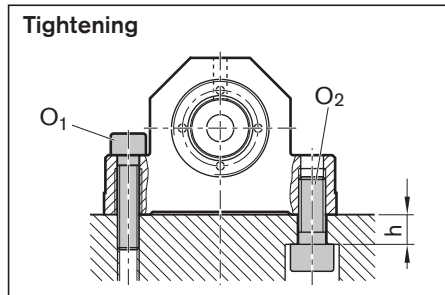

⚠ Align the screw with nut, the bearings and the guide such that they are completely flush with one another. The Rexroth gauge is suitable as an aid.

Size d ₀ xP	h (mm)	O ₁ DIN 912	O ₂ DIN 912	O ₃ , tapered pin (hardened) O ₄ , straight pin (DIN 6325)
6x1/2	8	M5x20	M6x16	4x20
8x1/2/2,5/5	8	M5x20	M6x16	4x20
12x2/5/10	8	M5x20	M6x16	4x20
16x5/10/16	11	M8x35	M10x25	8x40
20x5/10/20/40	11	M8x35	M10x25	8x40
25x5/10/25	14	M10x40	M12x30	10x50
32x5/10/20/32/64	14	M10x40	M12x30	10x50
40x5/10/12/16/20/25/30/40	16	M12x50	M14x35	10x50
50x5/10/12/16/20/25/30/40	16	M12x55	M14x35	10x60
63x10/20/40	16	M12x65	M14x35	10x70
80x10/20	22	M16x70	M20x50	12x80





Tightening torques for fastening screws according to VDI 2230 where $\mu_G = \mu_K = 0.125$ (friction coefficient)

Steel/steel material pairing

	Strength class for O ₁ ; O ₂	M5	M6	M8	M10	M12	M14	M20
 (Nm)	8.8	5.5	9.5	23	46	80	125	390
	12.9	9.5	16.0	39	77	135	215	650

Steel/aluminum and aluminum/ aluminum material pairings

	Strength class for O ₁ ; O ₂	M5	M6	M8	M10	M12	M14	M20
 (Nm)	8.8	4.8	8.5	20	41	70	110	345
	12.9	4.8	8.5	20	41	70	110	345

Mounting screws

⚠ Always make sure the screws are secure where there are high screw loads!

Lubrication of the end bearings

Bearings for ball screw assemblies are in general lubricated with grease for a lifetime of reliable service. This does not apply to our LGS bearings which are unsealed and therefore unlubricated! It should be noted, that grease lubrication does not facilitate the dissipation of heat in the bearings. The bearing temperature should therefore not exceed 50 °C, particularly in machine tool applications. At higher temperatures circulating oil lubrication must be set up. Angular-contact thrust ball bearings of series LGF, LGN are lifetime-lubricated with KE2P-35 grease as per DIN 51825. For regreasing, the quantities stated in the table below can be applied via the lube ports provided on the bearings. Where there are pairs of bearings, please note that each bearing must be individually lubricated via the lube port. Each bearing must be lubricated with half the value shown in the table. The maximum interval can be assumed to be 350 million revolutions, in which case the larger of the two quantities should be used. As a rule, the initial grease quantity will therefore last for the entire service life of a ball screw assembly.

Relubrication quantities for angular-contact thrust ball bearings LGF, LGN											
Abbreviation		Quantity (cm ³) ¹⁾		Abbreviation		Quantity (cm ³) ¹⁾		Abbreviation		Quantity (cm ³) ¹⁾	
LGN-B-0624		0.33	0.22								
LGN-B-1034		0.33	0.22								
LGN-B-1242	LGF-B-1255	0.43	0.33								
LGN-B-1747	LGF-B-1762	0.54	0.43								
LGN-B-2052	LGF-B-2068	0.87	0.54								
				LGN-C-2557	LGF-C-2575	2.17	1.3				
LGN-B-3062	LGF-B-3080	1.09	0.65	LGN-C-3062	LGF-C-3080	2.17	1.3				
LGN-B-3572	LGF-B-3590	1.74	0.98								
								LGN-A-4090	LGF-B-40115	6.52	3.80
								LGN-A-50110	LGF-A-50140	9.78	5.98

1) Shortened lubricating interval max. 10 M revolutions

2) Where there are pairs of bearings, lubricate each bearing via the lube port.
Lubricate each bearing with half the value shown in the table.

Angular-contact thrust ball bearings of series LGS are unsealed and therefore unlubricated.
For initial greasing, the quantity stated in the table below is to be applied to each bearing.

Initial lubrication quantities for angular-contact thrust ball bearings LGS		
Abbreviation	Quantity (cm ³)	
LGS-E-1030	1.09	
LGS-E-1232	2.17	
LGS-E-2047	LGS-E-1747	3.26
LGS-E-3072		7.61
LGS-E-3580		8.70
LGS-E-4090		10.87
LGS-E-50110		16.30
LGS-E-60130		21.74

Calculation

Resulting and equivalent bearing loads

For angular-contact thrust ball bearings LGN and LGF

Angular-contact thrust ball bearings are preloaded. The chart shows the resulting axial bearing load F_{ax} as a function of preload and axial operating load F_{Lax} .
For a purely axial load $F_{comb} = F_{ax}$.

$\alpha = 60^\circ$	X	Y
$\frac{F_{ax}}{F_{rad}} \leq 2.17$	1.90	0.55
$\frac{F_{ax}}{F_{rad}} > 2.17$	0.92	1.00

α = pressure angle
 F_{ax} = resulting bearing load
 F_{Lax} = operating load
 X, Y = dimensionless factor

If the radial operating forces are not insignificant, the equivalent bearing loads are calculated according to formula 20.
 Bearings for ball screw assemblies are also suitable to accommodate tipping forces.
 The moments that usually occur due to the mass and drive motion of the screw do not generally need to be included in the calculation of the equivalent bearing load.

$$F_{comb} = X \cdot F_{rad} + Y \cdot F_{ax} \quad 20$$

F_{ax} = resulting axial bearing load (N)
 F_{comb} = combined equivalent bearing load (N)
 F_{rad} = radial bearing load (N)

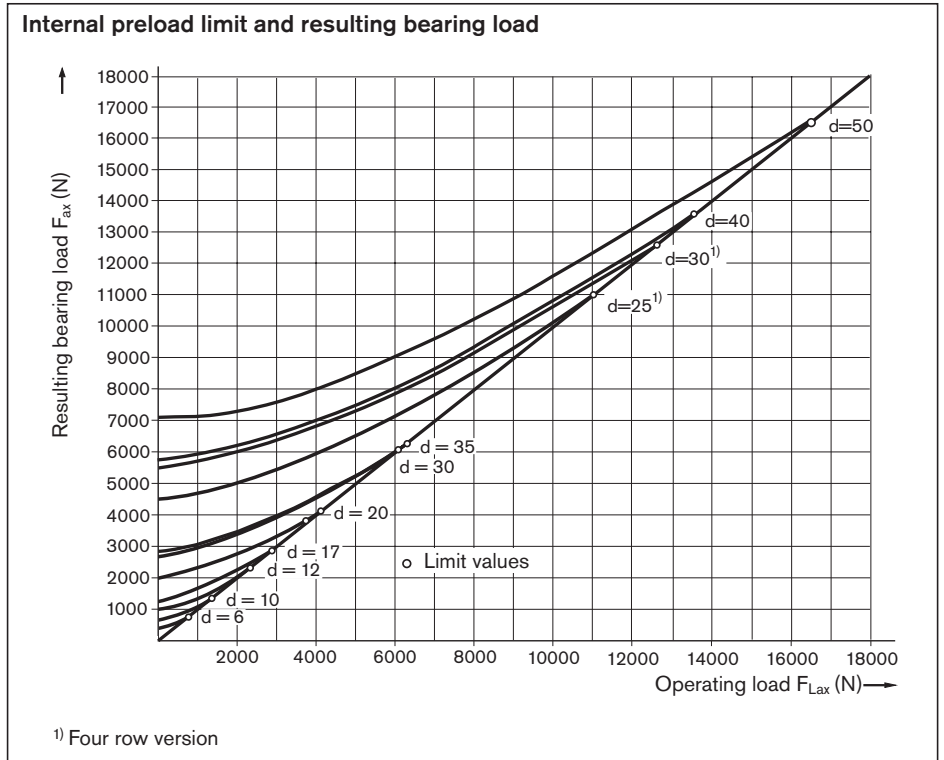

Permissible static axial load for bearing series LGF

The permissible static axial load of LGF series bearings in screw-down direction is:

$$F_{0ax p} \leq \frac{C_0}{2}$$

$F_{0ax p}$ = permissible static axial bearing load (N)

The static axial load rating C_0 is stated in the Dimension Tables.

⚠ Separate technical dimensioning to determine the limit values is absolutely necessary for all attachments (e.g. pillow block units, bearing assembly, etc.)

Calculation

Resulting and equivalent bearing loads

For angular-contact thrust ball bearings LGL

Before determining the combined equivalent load, F_{comb} , you must check the bearing size for the static limit load using the diagram. In this connection, the intersection point of the axial and radial bearing load must be below the muss boundary for a bearing to be suitable for the application.

$$F_{comb} = X \cdot F_{rad}^A + Y \cdot F_{ax}^B + Z \quad 21$$

Bearing size	X	Y	Z	A	B
LGL-D-0624	0.003	0.1300	140	1.90	1.40
LGL-A-1244	0.076	0.0460	580	1.28	1.30
LGL-A-1547	0.022	0.0110	540	1.45	1.50
LGL-A-2060	0.017	0.0082	960	1.45	1.50

- F_{ax} = axial bearing load (N)
- F_{comb} = combined equivalent bearing load (N)
- F_{rad} = radial bearing load (N)
- X, Y, Z = calculation factors (-)
- A, B = exponents (-)

Static limit load

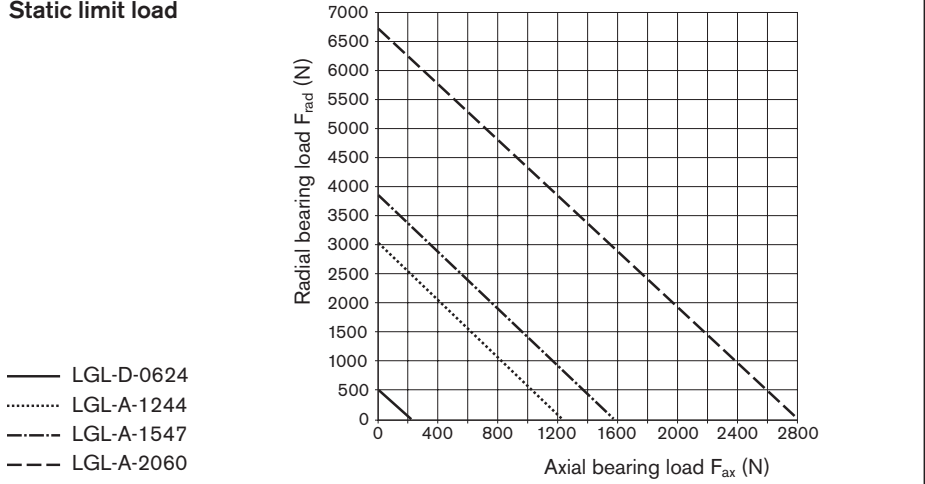

Average speed and average bearing load

When the bearing load varies in steps over a specific period of time 22, calculate the dynamic equivalent bearing.

When the speed varies, use formula 23. In these formulas q_t denotes the discrete time steps for the individual phases in %.

$$F_m = \sqrt[3]{F_{comb1}^3 \cdot \frac{|n_1|}{n_m} \cdot \frac{q_{t1}}{100} + F_{comb2}^3 \cdot \frac{|n_2|}{n_m} \cdot \frac{q_{t2}}{100} + \dots + F_{combn}^3 \cdot \frac{|n_n|}{n_m} \cdot \frac{q_{tn}}{100}} \quad 22$$

$$n_m = \frac{q_1}{100} \cdot n_1 + \frac{q_2}{100} \cdot n_2 + \dots + \frac{q_n}{100} \cdot n_n \quad 23$$

- $F_{comb1} \dots F_{combn}$ = combined equivalent axial load in phases 1 ... n (N)
- F_m = equivalent dynamic axial bearing load (N)
- $n_1 \dots n_n$ = speeds in phases 1 ... n (rpm)
- n_m = average speed (rpm)
- $q_{t1} \dots q_{tn}$ = discrete time steps in phases 1 ... n (%)

Service life and load safety factor

Nominal service life

The nominal service life is calculated as follows:

Attention:

Pay attention to the dynamic load rating of the nut!

$$L = \left(\frac{C}{F_m} \right)^3 \cdot 10^6 \quad 24$$

$$L_h = \frac{16\,666}{n_m} \cdot \left(\frac{C}{F_m} \right)^3 \quad 25$$

- C = dynamic bearing load rating (N)
- F_m = equivalent dynamic axial bearing load (N)
- L = nominal service life in revolutions (-)
- L_h = nominal service life in operating hours (h)
- n_m = average speed (rpm)

Static load safety factor

The static load safety factor for machine tools should not be lower than 4.

$$S_0 = \frac{C_0}{F_{0max}} \quad 26$$

- F_{0max} = maximum static load (N)
- C_0 = static load capacity (N)
- S_0 = static load safety factor (-)

Bosch Rexroth
 Linear Motion Technology

97419 Schweinfurt / Germany

Find your local contact person here: www.boschrexroth.com/adressen

Company: _____
 Contact: _____
 E-mail: _____
 Telephone: _____

Application

New design Revised design

Operating conditions

Discrete time step parameters			or	Dynamic cycle parameters											
Discrete time steps (%)	Speed (1/min)	Action of force x	Section	T1	T2	T3	T4	T5	T6	T7	T8	T9	T10	T11	T12
T ₁ =	n ₁ =		Path (mm)												
T ₂ =	n ₂ =		V (m/s)												
T ₃ =	n ₃ =		a (m/s ²)												
T ₄ =	n ₄ =		Time (s)												
T ₅ =	n ₅ =		Action of force x												
T ₆ =	n ₆ =														

Forces (N) =	F1	F2	F3	F4	F5	F6
Mass (kg) =	m1	m2	m3	m4	m5	m6
Bearing center-to-center distance (mm) =	or			Max. stroke (mm) =		

Bearing type

1. Tight

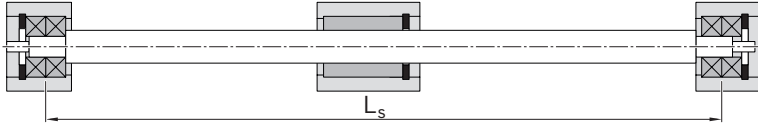

Tight

Installation Position
 Horizontal
 Vertical

2. Tight

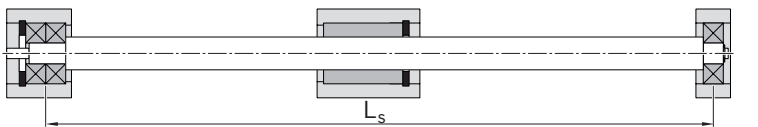

Loose

Drawing enclosed (recommended)

3. Tight

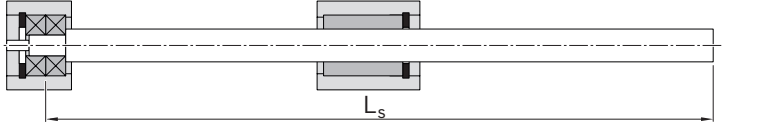

Free

Delivery with bearing

Required life: _____ Operating temperature: _____ °C Up to _____ °C

Type of lubrication: _____

Short description of the application / unusual operating conditions: _____

Visit our official homepage and use the provided configurators and our dimensioning program Linear Motion Designer free of charge.

