

# Ezi-SPEED<sup>®</sup>



## BLDC Motor Speed Control System

- AC Input (220V) BLDC Motor Speed Control System
- Modbus-RTU Based on RS-485 Communication
- Compact · Light Weight · High Power · High Efficiency Brushless Motor
- Wide Speed Control Range (50~4000 r/min)
- Stable Speed Control by Vector Control (Speed Regulation within 0.2%)
- 'Torque Limit' and 'Load Holding' Functions Supported
- Various Product Line-Up (30, 60, 120, 200, 400W)



CE

**FASTTECH**

*Fast, Accurate, Smooth Motion*



*Fast, Accurate, Smooth Motion*

**Ezi-SPEED**®



**BLDC Motor Speed Control System**



## 1 RS-485 based Modbus-RTU Control

Ezi-SPEED Modbus-RTU supports the Modbus-RTU protocol based on RS-485 communication, allowing for the construction of various control systems utilizing RS-485 in addition to input and output signal-based control. Modbus operates in a single master/multi-slave mode, where only the master can send commands, and each slave responds after executing the commands.

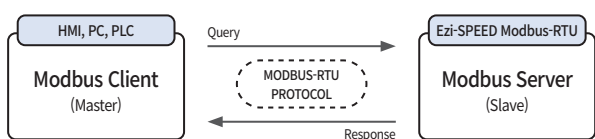

A single master controller can connect with up to 31 slaves (drives). The master controller can send commands to either a single slave or multiple slaves simultaneously

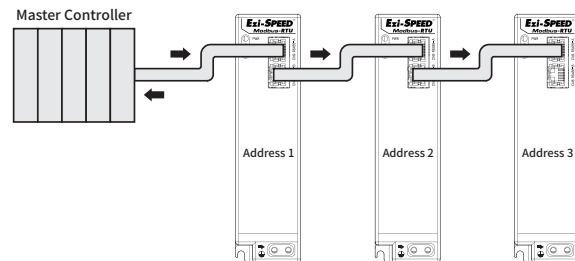

## 2 BLDC Motor Unit

General DC motors require regular maintenance as they use brushes and a commutator to rotate. In contrast BLDC (Brushless DC) motors have a long lifespan and excellent maintenance characteristics because they operate through a circuit composed of semiconductors without mechanical contacts. They incorporate permanent magnets in the rotor to enhance efficiency and maintain consistent torque characteristics across all speed ranges by automatically controlling motor current. Additionally, they utilize Hall IC for feedback control, allowing precise speed regulation from low to high speed.

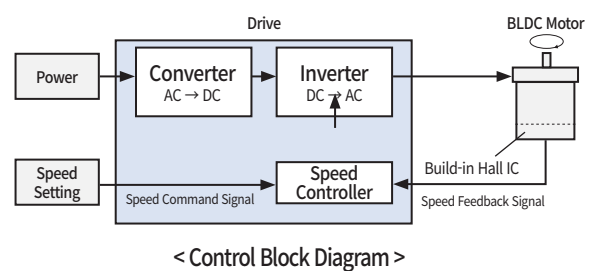

The BLDC motor has a constant torque from low speed to rated rotational speed. Therefore, it rotates at a stable speed no matter how the load changes in size. BLDC motor has continuous duty region (①) and limited duty region (②). Limited region can be used as the acceleration torque when starting the inertial stuff. However, in this region, if it's used for more than 40 seconds, overload protection is protected and the motor stops.

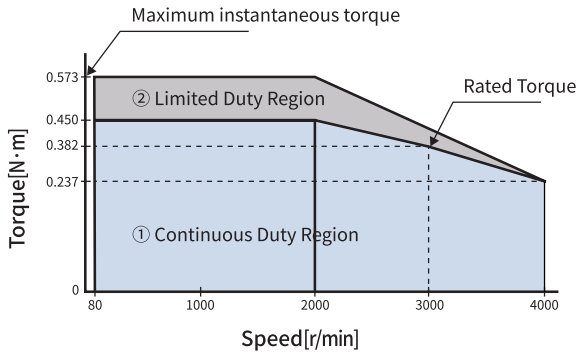

< Example of Torque Characteristics According to Speed of BLDC Motor >

### 3 High Precision Speed Control (Speed Regulation 0.2%)

Ezi-SPEED compares the setting speed with the speed feedback signals from the motor at all time, and adjusts the motor current using vector control algorithm. So, even if the load changes, stable rotation is maintained from low speed to high speed. Inverter controlled AC induction motor does not perform feedback control, so the speed will be reduced significantly when load increases.

Ezi-SPEED is recommended for applications that require stable speed.

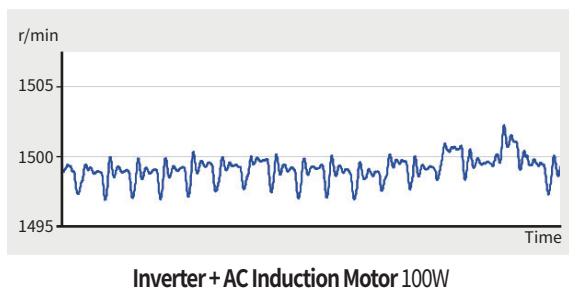
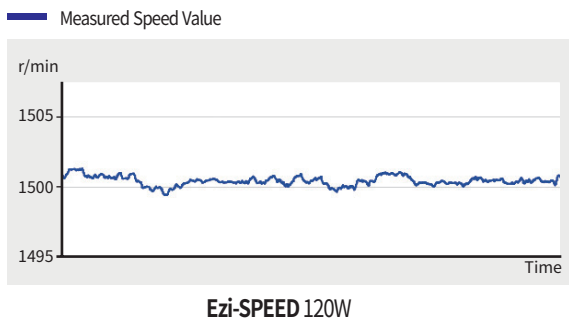

\* Load Factor : 95%    \* Setting Speed : 1,500r/min  
 \* Resolution of External Encoder for Measuring Velocity Ripple : 32,000P/R

### 4 Wide Speed Control Range (Speed Ratio: 1:80)

Ezi-SPEED has wide speed control range compared to AC induction motor with inverter. Because torque is not restricted at low speed, Ezi-SPEED is recommended for application that requires stable torque over from low to high speed.

Product	Speed Control Range [r/min]	Speed Ratio
Ezi-SPEED	50~4,000	1:80
Inverter + AC Induction Motor	200~2,400	1:12

\* Speed range of Inverter + AC Induction Motor varies depending on model type.

### 5 Compact / Light Weight / High Power / High Efficiency

Unlike AC induction motors, BLDC motors use permanent magnets in the rotor so that it could prevent secondary loss from rotor.

Therefore, BLDC motors has higher efficiency than inverter-controlled AC induction motor so that customers can save energy.

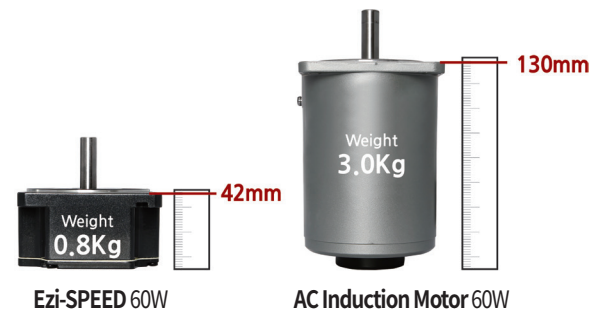

- Comparison of motor temperature after 4 hours continuous operation when load factor is 100% and Setting speed is 1,500 r/min.

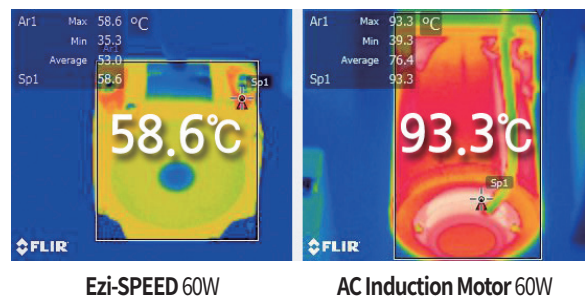

## 6 Torque Limit Function

Ezi-SPEED provides this function to control the torque by limiting the current flowing through the motor. Torque limit function can be used to prevent excessive force.

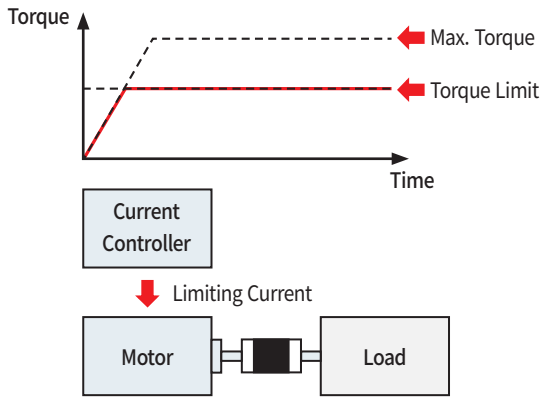

## 7 Load Holding Function

Load holding function can be used for an electrical retention brake at stop without the need for a mechanical brake. So, this function is suitable for applications that perform work while stopping the transportation conveyors.

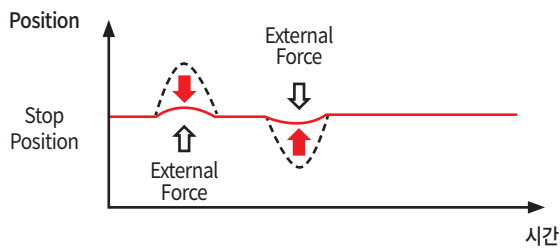

## 8 Operation by External I/O

A controller, such as a PLC, can perform operations such as starting, stopping, changing the direction of rotation, and multi-speed operation. Additionally, the speed can be adjusted by applying external DC voltage or by connecting a potentiometer.

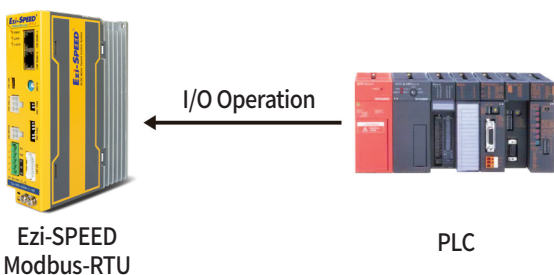

## 9 16-Speed Settings

16-speed operation can be done by setting operation data No. 0 to No. 15. Operation data can be configured using Ezi-SPEED Setting program or through RS-485 communication.

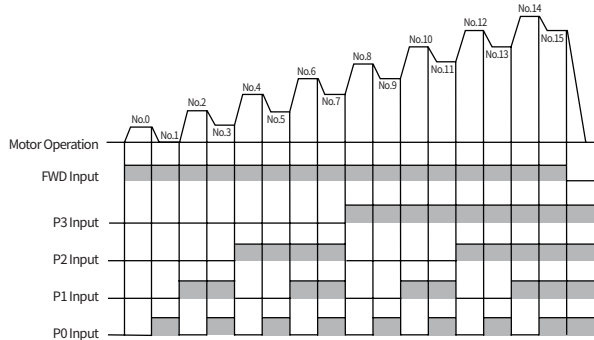

## 10 Ezi-SPEED Setting program

Ezi-SPEED Modbus-RTU can perform various functions using the separately provided Ezi-SPEED Setting program.

- Parameter Setting Function: Easily modify and save various parameters.
- Monitoring Function: Easily monitor the internal status of the drive and motor, including speed, load factor, I/O signals, alarms, and warnings.
- Testing Function: Easily test whether the drive and motor are operating correctly.

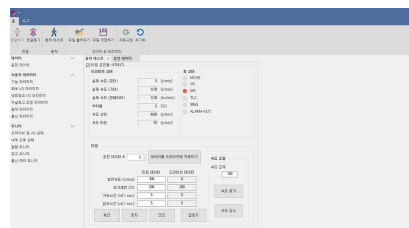

## 11 Protection Function

- Ezi-SPEED detects abnormal situations like overload, over voltage etc. When this happens, the operation is stopped and alarm is displayed.
- A regenerative resistor can be used when the deceleration time is short or when the large inertia load is used. Also the protection function can be activated for the excessive external force acting on the motor shaft.

## Ezi-SPEED Part Numbering

### Ezi-SPEED-MR-60-H-30-C-R5-P

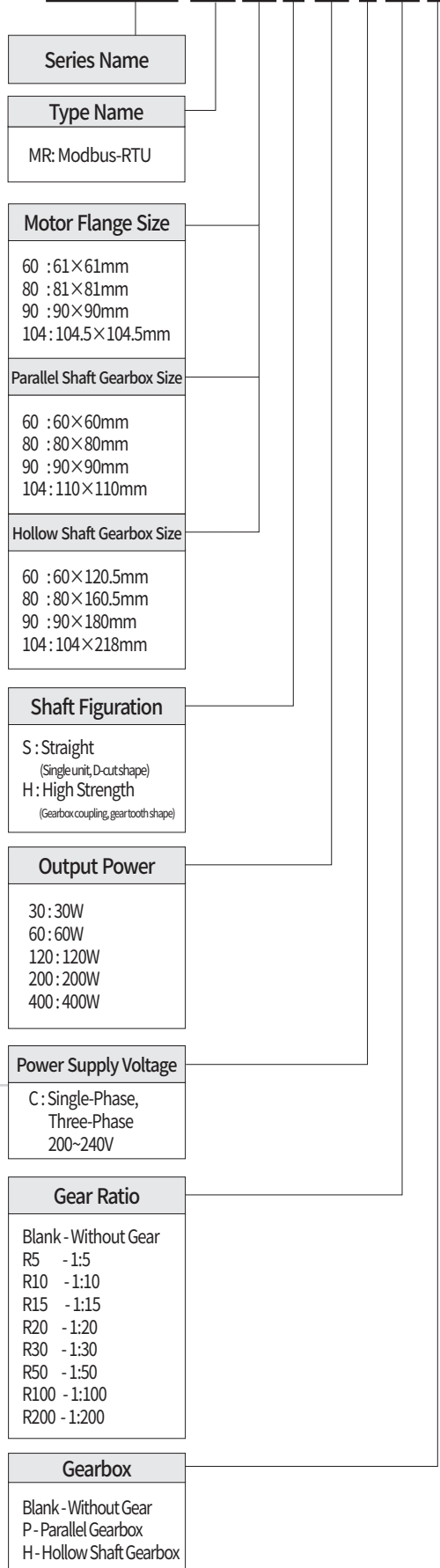

FASTECH Ezi-SPEED Modbus-RTU

## Standard Combination

Output Power	Unit Part Number	Motor Model Number	Drive Model Number
30W	Ezi-SPEED-MR-60-S-30-C	ESM-60-S-30	ESD-MR-30-C
60W	Ezi-SPEED-MR-80-S-60-C	ESM-80-S-60	ESD-MR-60-C
120W	Ezi-SPEED-MR-90-S-120-C	ESM-90-S-120	ESD-MR-120-C
200W	Ezi-SPEED-MR-104-S-200-C	ESM-104-S-200	ESD-MR-200-C
400W	Ezi-SPEED-MR-104-S-400-C	ESM-104-S-400	ESD-MR-400-C

## Combination with Gearbox

Output Power	Unit Part Number	Motor Model Number	Drive Model Number	Gearbox Model Number	Gear Ratio
30W	Ezi-SPEED-MR-60-H-30-C-R5-P	ESM-60-H-30	ESD-MR-30-C	ESG-60-H-R5-P	1:5
	Ezi-SPEED-MR-60-H-30-C-R5-H			ESG-60-H-R5-H	
	Ezi-SPEED-MR-60-H-30-C-R10-P			ESG-60-H-R10-P	1:10
	Ezi-SPEED-MR-60-H-30-C-R10-H			ESG-60-H-R10-H	
	Ezi-SPEED-MR-60-H-30-C-R15-P			ESG-60-H-R15-P	1:15
	Ezi-SPEED-MR-60-H-30-C-R15-H			ESG-60-H-R15-H	
	Ezi-SPEED-MR-60-H-30-C-R20-P			ESG-60-H-R20-P	1:20
	Ezi-SPEED-MR-60-H-30-C-R20-H			ESG-60-H-R20-H	
	Ezi-SPEED-MR-60-H-30-C-R30-P			ESG-60-H-R30-P	1:30
	Ezi-SPEED-MR-60-H-30-C-R30-H			ESG-60-H-R30-H	
	Ezi-SPEED-MR-60-H-30-C-R50-P			ESG-60-H-R50-P	1:50
	Ezi-SPEED-MR-60-H-30-C-R50-H			ESG-60-H-R50-H	
	Ezi-SPEED-MR-60-H-30-C-R100-P			ESG-60-H-R100-P	1:100
	Ezi-SPEED-MR-60-H-30-C-R100-H			ESG-60-H-R100-H	
	Ezi-SPEED-MR-60-H-30-C-R200-P			ESG-60-H-R200-P	1:200
	Ezi-SPEED-MR-60-H-30-C-R200-H			ESG-60-H-R200-H	

## Combination with Gearbox

Output Power	Unit Part Number	Motor Model Number	Drive Model Number	Gearbox Model Number	Gear Ratio			
60W	Ezi-SPEED-MR-80-H-60-C-R5-P	ESM-80-H-60	ESD-MR-60-C	ESG-80-H-R5-P	1:5			
	Ezi-SPEED-MR-80-H-60-C-R5-H			ESG-80-H-R5-H				
	Ezi-SPEED-MR-80-H-60-C-R10-P			ESG-80-H-R10-P	1:10			
	Ezi-SPEED-MR-80-H-60-C-R10-H			ESG-80-H-R10-H				
	Ezi-SPEED-MR-80-H-60-C-R15-P			ESG-80-H-R15-P	1:15			
	Ezi-SPEED-MR-80-H-60-C-R15-H			ESG-80-H-R15-H				
	Ezi-SPEED-MR-80-H-60-C-R20-P			ESG-80-H-R20-P	1:20			
	Ezi-SPEED-MR-80-H-60-C-R20-H			ESG-80-H-R20-H				
	Ezi-SPEED-MR-80-H-60-C-R30-P			ESG-80-H-R30-P	1:30			
	Ezi-SPEED-MR-80-H-60-C-R30-H			ESG-80-H-R30-H				
	Ezi-SPEED-MR-80-H-60-C-R50-P			ESG-80-H-R50-P	1:50			
	Ezi-SPEED-MR-80-H-60-C-R50-H			ESG-80-H-R50-H				
	Ezi-SPEED-MR-80-H-60-C-R100-P			ESG-80-H-R100-P	1:100			
	Ezi-SPEED-MR-80-H-60-C-R100-H			ESG-80-H-R100-H				
	Ezi-SPEED-MR-80-H-60-C-R200-P			ESG-80-H-R200-P	1:200			
	Ezi-SPEED-MR-80-H-60-C-R200-H			ESG-80-H-R200-H				
	120W			Ezi-SPEED-MR-90-H-120-C-R5-P	ESM-90-H-120	ESD-MR-120-C	ESG-90-H-R5-P	1:5
				Ezi-SPEED-MR-90-H-120-C-R5-H			ESG-90-H-R5-H	
Ezi-SPEED-MR-90-H-120-C-R10-P		ESG-90-H-R10-P	1:10					
Ezi-SPEED-MR-90-H-120-C-R10-H		ESG-90-H-R10-H						
Ezi-SPEED-MR-90-H-120-C-R15-P		ESG-90-H-R15-P	1:15					
Ezi-SPEED-MR-90-H-120-C-R15-H		ESG-90-H-R15-H						
Ezi-SPEED-MR-90-H-120-C-R20-P		ESG-90-H-R20-P	1:20					
Ezi-SPEED-MR-90-H-120-C-R20-H		ESG-90-H-R20-H						
Ezi-SPEED-MR-90-H-120-C-R30-P		ESG-90-H-R30-P	1:30					
Ezi-SPEED-MR-90-H-120-C-R30-H		ESG-90-H-R30-H						
Ezi-SPEED-MR-90-H-120-C-R50-P		ESG-90-H-R50-P	1:50					
Ezi-SPEED-MR-90-H-120-C-R50-H		ESG-90-H-R50-H						
Ezi-SPEED-MR-90-H-120-C-R100-P		ESG-90-H-R100-P	1:100					
Ezi-SPEED-MR-90-H-120-C-R100-H		ESG-90-H-R100-H						
Ezi-SPEED-MR-90-H-120-C-R200-P		ESG-90-H-R200-P	1:200					
Ezi-SPEED-MR-90-H-120-C-R200-H		ESG-90-H-R200-H						

Output Power	Unit Part Number	Motor Model Number	Drive Model Number	Gearbox Model Number	Gear Ratio
200W	Ezi-SPEED-MR-104-H-200-C-R5-P	ESM-104-H-200	ESD-MR-200-C	ESG-104-H-R5-P	1:5
	Ezi-SPEED-MR-104-H-200-C-R5-H			ESG-104-H-R5-H	
	Ezi-SPEED-MR-104-H-200-C-R10-P			ESG-104-H-R10-P	1:10
	Ezi-SPEED-MR-104-H-200-C-R10-H			ESG-104-H-R10-H	
	Ezi-SPEED-MR-104-H-200-C-R15-P			ESG-104-H-R15-P	1:15
	Ezi-SPEED-MR-104-H-200-C-R15-H			ESG-104-H-R15-H	
	Ezi-SPEED-MR-104-H-200-C-R20-P			ESG-104-H-R20-P	1:20
	Ezi-SPEED-MR-104-H-200-C-R20-H			ESG-104-H-R20-H	
	Ezi-SPEED-MR-104-H-200-C-R30-P			ESG-104-H-R30-P	1:30
	Ezi-SPEED-MR-104-H-200-C-R30-H			ESG-104-H-R30-H	
	Ezi-SPEED-MR-104-H-200-C-R50-P			ESG-104-H-R50-P	1:50
	Ezi-SPEED-MR-104-H-200-C-R50-H			ESG-104-H-R50-H	
	Ezi-SPEED-MR-104-H-200-C-R100-P			ESG-104-H-R100-P	1:100
	Ezi-SPEED-MR-104-H-200-C-R100-H			ESG-104-H-R100-H	
	Ezi-SPEED-MR-104-H-200-C-R200-P			ESG-104-H-R200-P	1:200
	Ezi-SPEED-MR-104-H-400-C-R5-P			ESG-104-H-R5-P	
	Ezi-SPEED-MR-104-H-400-C-R5-H			ESG-104-H-R5-H	
	Ezi-SPEED-MR-104-H-400-C-R10-P			ESG-104-H-R10-P	1:10
Ezi-SPEED-MR-104-H-400-C-R10-H	ESG-104-H-R10-H				
Ezi-SPEED-MR-104-H-400-C-R15-P	ESG-104-H-R15-P	1:15			
Ezi-SPEED-MR-104-H-400-C-R15-H	ESG-104-H-R15-H				
Ezi-SPEED-MR-104-H-400-C-R20-P	ESG-104-H-R20-P	1:20			
Ezi-SPEED-MR-104-H-400-C-R20-H	ESG-104-H-R20-H				
Ezi-SPEED-MR-104-H-400-C-R30-P	ESG-104-H-R30-P	1:30			
Ezi-SPEED-MR-104-H-400-C-R30-H	ESG-104-H-R30-H				
Ezi-SPEED-MR-104-H-400-C-R50-P	ESG-104-H-R50-P	1:50			
Ezi-SPEED-MR-104-H-400-C-R50-H	ESG-104-H-R50-H				
Ezi-SPEED-MR-104-H-400-C-R100-P	ESG-104-H-R100-P	1:100			
Ezi-SPEED-MR-104-H-400-C-R100-H	ESG-104-H-R100-H				
Ezi-SPEED-MR-104-H-400-C-R200-P	ESG-104-H-R200-P	1:200			
Ezi-SPEED-MR-104-H-400-C-R200-H	ESG-104-H-R200-H				

## Specifications of Drive

Drive Model		ESD-MR-30-C	ESD-MR-60-C	ESD-MR-120-C	ESD-MR-200-C	ESD-MR-400-C
Rated Output Power		30W	60W	120W	200W	400W
Input Voltage		Single-Phase 200~240V / Three-Phase 200~240V				
Frequency		50/60Hz				
Permissible Frequency Range		±10%				
Rated Input Current		Single-Phase : 0.88A Three-Phase : 0.51A	Single-Phase : 1.55A Three-Phase : 0.90A	Single-Phase : 2.43A Three-Phase : 1.41A	Single-Phase : 3.42A Three-Phase : 1.97A	Single-Phase : 5.64A Three-Phase : 3.26A
Maximum Input Current		Single-Phase : 1.9A Three-Phase : 1.1A	Single-Phase : 2.8A Three-Phase : 1.7A	Single-Phase : 4.5A Three-Phase : 2.6A	Single-Phase : 5.47A Three-Phase : 3.16A	Single-Phase : 7.85A Three-Phase : 4.53A
Environment	Temperature	· In Use: 0~40°C · In Storage: -20~70°C				
	Humidity	· In Use: 35~85% RH (Non-Condensing) · In Storage: 10~90% RH (Non-Condensing)				
	Vibration Resistant	0.5g				
Function	Speed Control Range	50~4000r/min				
	Rated Speed	3000r/min				
	Speed Regulation	0.2% or less / Conditions: 0~Rated Torque, Rated Speed, Rated Voltage, Normal Temperature				
	Rated Torque	0.096N·m	0.191N·m	0.382N·m	0.637N·m	1.27N·m
	Maximum Instantaneous Torque	0.144N·m	0.287N·m	0.573N·m	1.15N·m	1.91N·m
	Error Types	Overcurrent, Overspeed, Overheat, Overvoltage, Sensor Error, Undervoltage, Internal Circuit Error, EEPROM Error, External Error, Initial Operation Prohibition, RS-485 Comm. Error, RS-485 Comm. Time Out				
	LED Display	Power, Error, Communication				
	Network	· RS-485 Modbus-RTU Communication · Baudrate: 9,600 ~ 115,200 bps				
	Supporting Software	Ezi-SPEED Setting program				
I/O Signal	Input	7 User Inputs (Photocoupler Insulation)				
	Output	2 User Outputs (Photocoupler Insulation)				



# ● Dimensions of Drive [mm]

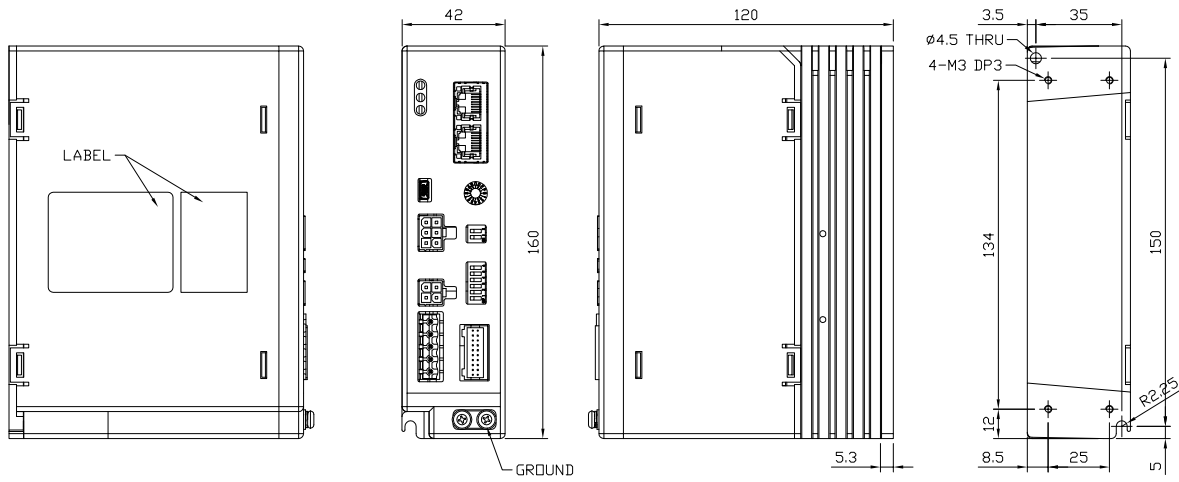

## ● Specifications of Motor

Model			UNIT	ESM-60-S-30	ESM-80-S-60	ESM-90-S-120	ESM-104-S-200	ESM-104-S-400
Rated Output Power (Continuous)			W	30	60	120	200	400
Rated Torque			N·m	0.096	0.192	0.382	0.637	1.272
Rated Input Current			A	0.21	0.36	0.85	1.65	2.37
Rated Speed			r/min	3,000				
Permissible Load Inertia Moment			$10^{-4}\text{kg}\cdot\text{m}^2$	0.5	1.8	5.8	5.8	8.75
Inertia Moment			$10^{-4}\text{kg}\cdot\text{m}^2$	0.086	0.234	0.61	0.61	0.66
Weight			kg	0.5	0.8	1.3	2.4	2.4
Length			mm	62	74	94	156	156
Permissible Radial Load	Distance from End of Shaft	10mm	N	70	120	160	197	197
		20mm		100	140	170	220	220

# Torque Characteristics of Motor

**Ezi-SPEED-30W**

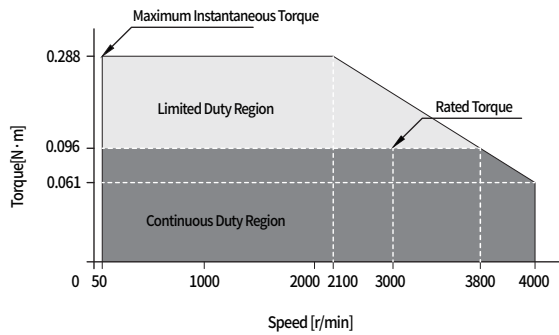

**Ezi-SPEED-60W**

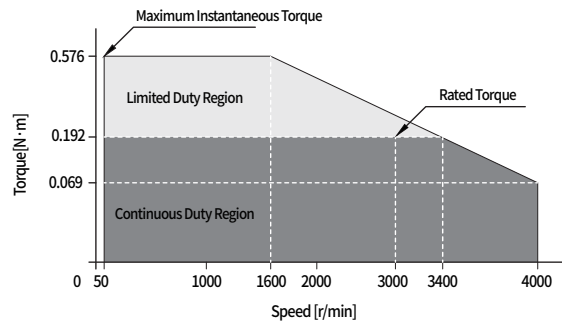

**Ezi-SPEED-120W**

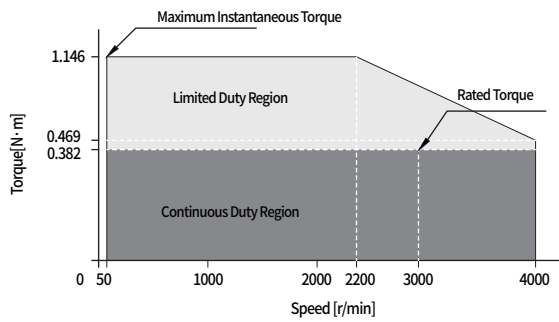

**Ezi-SPEED-200W**

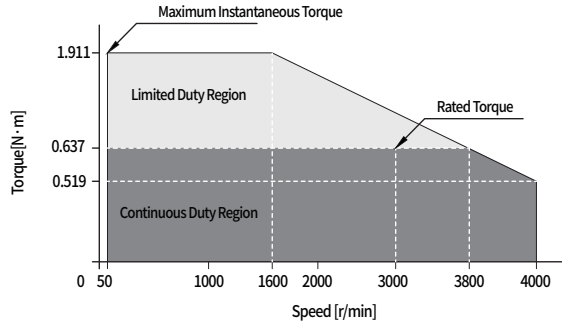

**Ezi-SPEED-400W**

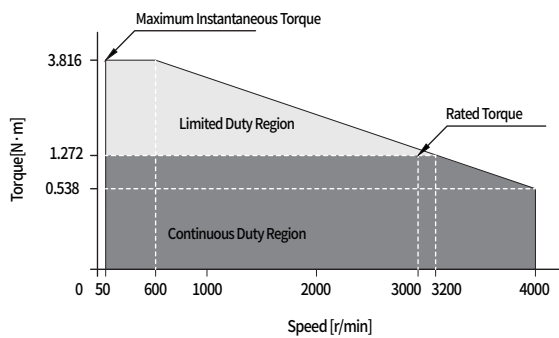

● Dimensions of Motor [mm]

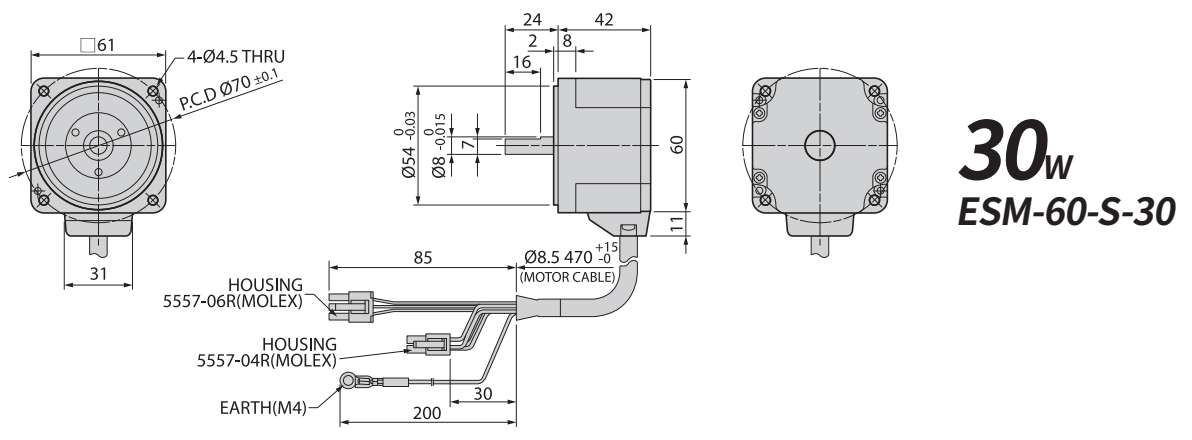

**30<sub>W</sub>**  
**ESM-60-S-30**

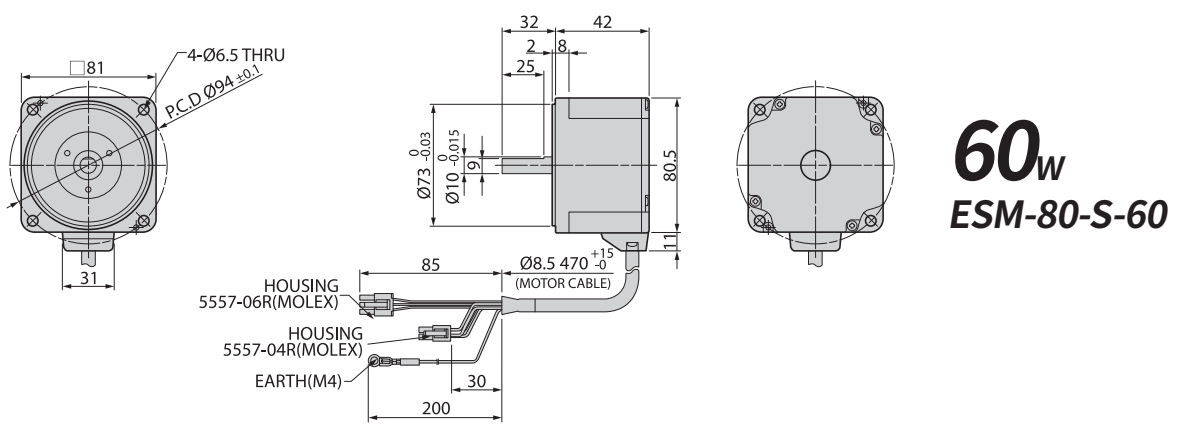

**60<sub>W</sub>**  
**ESM-80-S-60**

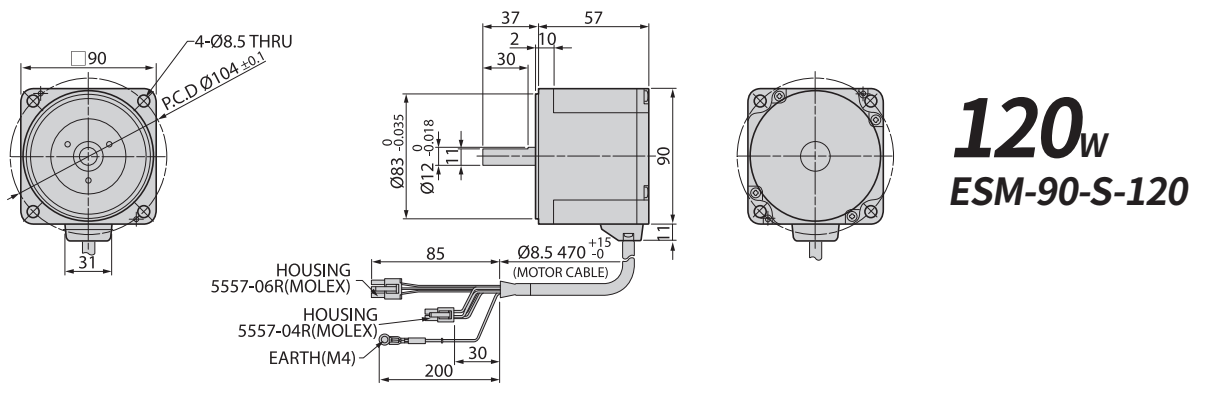

**120<sub>W</sub>**  
**ESM-90-S-120**

FASTECH Ezi-SPEED Modbus-RTU

## ● Dimensions of Motor [mm]

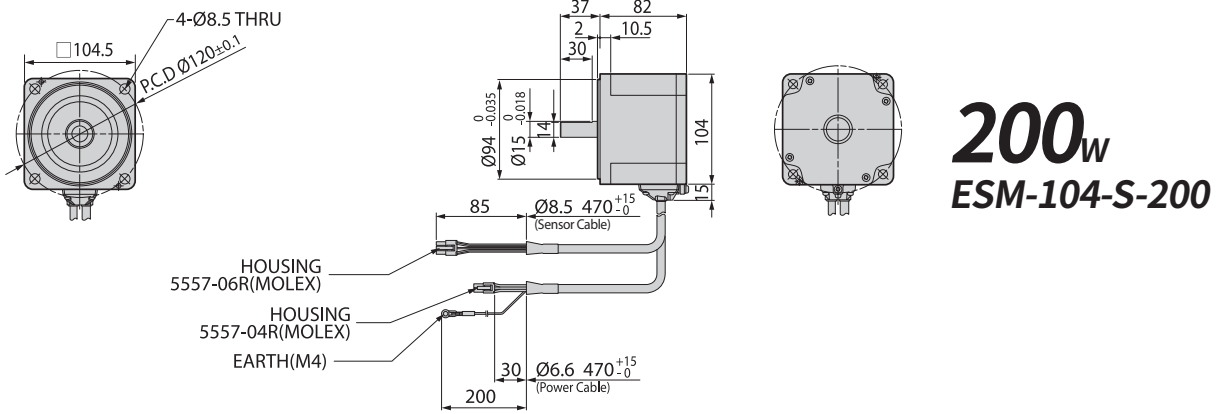

**200<sub>W</sub>**  
**ESM-104-S-200**

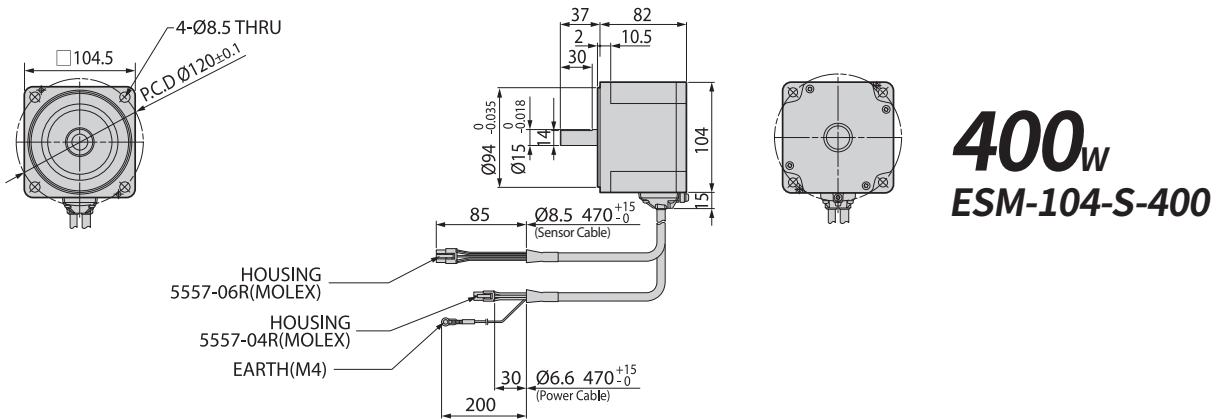

**400<sub>W</sub>**  
**ESM-104-S-400**

## ● Specifications of Motor with Parallel Shaft Gearbox

### 30<sub>w</sub>

Unit Part Number	Gear Ratio	Permissible Torque [N·m]		Permissible Speed Range [r/min]	Unit Weight [kg]	Permissible Radial Load [N]		Permissible Axial Load [N]
		50~3,000 [r/min]	4,000 [r/min]			Distance from End of Shaft [mm]		
						10	20	
Ezi-SPEED-MR-60-H-30-C-R5-P	5	0.45	0.34	10~800	0.9	100	150	40
Ezi-SPEED-MR-60-H-30-C-R10-P	10	0.9	0.68	5~400		150	200	
Ezi-SPEED-MR-60-H-30-C-R15-P	15	1.35	1	3.3~266.7				
Ezi-SPEED-MR-60-H-30-C-R20-P	20	1.8	1.4	2.5~200				
Ezi-SPEED-MR-60-H-30-C-R30-P	30	2.6	1.9	1.7~133.3		200	300	
Ezi-SPEED-MR-60-H-30-C-R50-P	50	4.3	3.2	1~80				
Ezi-SPEED-MR-60-H-30-C-R100-P	100	6	5.4	0.5~40				
Ezi-SPEED-MR-60-H-30-C-R200-P	200	6	5.4	0.25~20				

### 60<sub>w</sub>

Unit Part Number	Gear Ratio	Permissible Torque [N·m]		Permissible Speed Range [r/min]	Unit Weight [kg]	Permissible Radial Load [N]		Permissible Axial Load [N]
		50~3,000 [r/min]	4,000 [r/min]			Distance from End of Shaft [mm]		
						10	20	
Ezi-SPEED-MR-80-H-60-C-R5-P	5	0.9	0.68	10~800	1.6	200	250	100
Ezi-SPEED-MR-80-H-60-C-R10-P	10	1.8	1.4	5~400		300	350	
Ezi-SPEED-MR-80-H-60-C-R15-P	15	2.7	2	3.3~266.7				
Ezi-SPEED-MR-80-H-60-C-R20-P	20	3.6	2.7	2.5~200		450	550	
Ezi-SPEED-MR-80-H-60-C-R30-P	30	5.2	3.9	1.7~133.3				
Ezi-SPEED-MR-80-H-60-C-R50-P	50	8.6	6.5	1~80				
Ezi-SPEED-MR-80-H-60-C-R100-P	100	16	12.9	0.5~40				
Ezi-SPEED-MR-80-H-60-C-R200-P	200	16	14	0.25~20				

## Specifications of Motor with Parallel Shaft Gearbox

### 120<sub>w</sub>

Unit Part Number	Gear Ratio	Permissible Torque [N·m]		Permissible Speed Range [r/min]	Unit Weight [kg]	Permissible Radial Load [N]		Permissible Axial Load [N]
		50~3,000 [r/min]	4,000 [r/min]			Distance from End of Shaft [mm]		
						10	20	
Ezi-SPEED-MR-90-H-120-C-R5-P	5	2.2	1.4	10~800	2.7	300	400	150
Ezi-SPEED-MR-90-H-120-C-R10-P	10	4.4	2.7	5~400		400	500	
Ezi-SPEED-MR-90-H-120-C-R15-P	15	6.6	4.1	3.3~266.7				
Ezi-SPEED-MR-90-H-120-C-R20-P	20	8.8	5.4	2.5~200				
Ezi-SPEED-MR-90-H-120-C-R30-P	30	12.6	7.7	1.7~133.3		500	650	
Ezi-SPEED-MR-90-H-120-C-R50-P	50	21.1	12.9	1~80				
Ezi-SPEED-MR-90-H-120-C-R100-P	100	30	25.8	0.5~40				
Ezi-SPEED-MR-90-H-120-C-R200-P	200	30	27	0.25~20				

### 200<sub>w</sub>

Unit Part Number	Gear Ratio	Permissible Torque [N·m]		Permissible Speed Range [r/min]	Unit Weight [kg]	Permissible Radial Load [N]		Permissible Axial Load [N]
		50~3,000 [r/min]	4,000 [r/min]			Distance from End of Shaft [mm]		
						10	20	
Ezi-SPEED-MR-104-H-200-C-R5-P	5	2.9	2	10~800	4.2	550	800	200
Ezi-SPEED-MR-104-H-200-C-R10-P	10	5.9	4.1	5~400				
Ezi-SPEED-MR-104-H-200-C-R15-P	15	8.8	6.1	3.3~266.7				
Ezi-SPEED-MR-104-H-200-C-R20-P	20	11.7	8.1	2.5~200		1,000	1,250	300
Ezi-SPEED-MR-104-H-200-C-R30-P	30	16.8	11.6	1.7~133.3				
Ezi-SPEED-MR-104-H-200-C-R50-P	50	28	19.4	1~80		1,400	1,700	400
Ezi-SPEED-MR-104-H-200-C-R100-P	100	52.7	36.5	0.5~40				
Ezi-SPEED-MR-104-H-200-C-R200-P	200	70	63	0.25~20				

## ● Specifications of Motor with Parallel Shaft Gearbox

# 400<sub>w</sub>

Unit Part Number	Gear Ratio	Permissible Torque [N·m]		Permissible Speed Range [r/min]	Unit Weight [kg]	Permissible Radial Load [N]		Permissible Axial Load [N]
		50~3,000 [r/min]	4,000 [r/min]			Distance from End of Shaft [mm]		
						10	20	
Ezi-SPEED-MR-104-H-400-C-R5-P	5	5.9	4.3	10~800	4.2	550	800	200
Ezi-SPEED-MR-104-H-400-C-R10-P	10	11.7	8.6	5~400				
Ezi-SPEED-MR-104-H-400-C-R15-P	15	17.6	12.8	3.3~266.7				
Ezi-SPEED-MR-104-H-400-C-R20-P	20	23.4	17.1	2.5~200		1,000	1,250	300
Ezi-SPEED-MR-104-H-400-C-R30-P	30	33.5	24.5	1.7~133.3				
Ezi-SPEED-MR-104-H-400-C-R50-P	50	55.9	40.9	1~80		1,400	1,700	400
Ezi-SPEED-MR-104-H-400-C-R100-P	100	70	63	0.5~40				
Ezi-SPEED-MR-104-H-400-C-R200-P	200	70	63	0.25~20				



## ● Specifications of Motor with Hollow Shaft Gearbox

### 30<sub>w</sub>

Unit Part Number	Gear Ratio	Permissible Torque [N·m]		Permissible Speed Range [r/min]	Unit Weight [kg]	Permissible Radial Load [N]		Permissible Axial Load [N]
		50~3,000 [r/min]	4,000 [r/min]			Distance from End of Shaft [mm]		
						10	20	
Ezi-SPEED-MR-60-H-30-C-R5-H	5	0.4	0.3	10~800	1.2	450	370	200
Ezi-SPEED-MR-60-H-30-C-R10-H	10	0.85	0.64	5~400				
Ezi-SPEED-MR-60-H-30-C-R15-H	15	1.3	0.96	3.3~266.7				
Ezi-SPEED-MR-60-H-30-C-R20-H	20	1.7	1.3	2.5~200				
Ezi-SPEED-MR-60-H-30-C-R30-H	30	2.6	1.9	1.7~133.3				
Ezi-SPEED-MR-60-H-30-C-R50-H	50	4.3	3.2	1~80				
Ezi-SPEED-MR-60-H-30-C-R100-H	100	8.5	6.4	0.5~40				
Ezi-SPEED-MR-60-H-30-C-R200-H	200	17	12.8	0.25~20				

### 60<sub>w</sub>

Unit Part Number	Gear Ratio	Permissible Torque [N·m]		Permissible Speed Range [r/min]	Unit Weight [kg]	Permissible Radial Load [N]		Permissible Axial Load [N]
		50~3,000 [r/min]	4,000 [r/min]			Distance from End of Shaft [mm]		
						10	20	
Ezi-SPEED-MR-80-H-60-C-R5-H	5	0.85	0.64	10~800	2.2	800	660	400
Ezi-SPEED-MR-80-H-60-C-R10-H	10	1.7	1.3	5~400				
Ezi-SPEED-MR-80-H-60-C-R15-H	15	2.6	1.9	3.3~266.7				
Ezi-SPEED-MR-80-H-60-C-R20-H	20	3.4	2.6	2.5~200				
Ezi-SPEED-MR-80-H-60-C-R30-H	30	5.1	3.8	1.7~133.3				
Ezi-SPEED-MR-80-H-60-C-R50-H	50	8.5	6.4	1~80				
Ezi-SPEED-MR-80-H-60-C-R100-H	100	17	12.8	0.5~40				
Ezi-SPEED-MR-80-H-60-C-R200-H	200	34	25.5	0.25~20				

## ● Specifications of Motor with Hollow Shaft Gearbox

# 120<sub>w</sub>

Unit Part Number	Gear Ratio	Permissible Torque [N·m]		Permissible Speed Range [r/min]	Unit Weight [kg]	Permissible Radial Load [N]		Permissible Axial Load [N]
		50~3,000 [r/min]	4,000 [r/min]			Distance from End of Shaft [mm]		
						10	20	
Ezi-SPEED-MR-90-H-120-C-R5-H	5	2.1	1.3	10~800	3.3	900	770	500
Ezi-SPEED-MR-90-H-120-C-R10-H	10	4.2	2.6	5~400				
Ezi-SPEED-MR-90-H-120-C-R15-H	15	6.2	3.8	3.3~266.7		1,300	1,000	
Ezi-SPEED-MR-90-H-120-C-R20-H	20	8.3	5.1	2.5~200				
Ezi-SPEED-MR-90-H-120-C-R30-H	30	12.5	7.7	1.7~133.3		1,500	1,280	
Ezi-SPEED-MR-90-H-120-C-R50-H	50	21	12.8	1~80				
Ezi-SPEED-MR-90-H-120-C-R100-H	100	42	25.5	0.5~40				
Ezi-SPEED-MR-90-H-120-C-R200-H	200	68	51	0.25~20				

# 200<sub>w</sub>

Unit Part Number	Gear Ratio	Permissible Torque [N·m]		Permissible Speed Range [r/min]	Unit Weight [kg]	Permissible Radial Load [N]		Permissible Axial Load [N]
		50~3,000 [r/min]	4,000 [r/min]			Distance from End of Shaft [mm]		
						10	20	
Ezi-SPEED-MR-104-H-200-C-R5-H	5	2.8	1.9	10~800	4.2	1,230	1,070	800
Ezi-SPEED-MR-104-H-200-C-R10-H	10	5.5	3.8	5~400				
Ezi-SPEED-MR-104-H-200-C-R15-H	15	8.3	5.7	3.3~266.7		1,680	1,470	
Ezi-SPEED-MR-104-H-200-C-R20-H	20	11.1	7.7	2.5~200				
Ezi-SPEED-MR-104-H-200-C-R30-H	30	16.6	11.5	1.7~133.3		2,040	1,780	
Ezi-SPEED-MR-104-H-200-C-R50-H	50	27.6	19.1	1~80				
Ezi-SPEED-MR-104-H-200-C-R100-H	100	55.3	38.3	0.25~20				

## ● Specifications of Motor with Hollow Shaft Gearbox

# 400<sub>w</sub>

Unit Part Number	Gear Ratio	Permissible Torque [N·m]		Permissible Speed Range [r/min]	Unit Weight [kg]	Permissible Radial Load [N]		Permissible Axial Load [N]
		50~3,000 [r/min]	4,000 [r/min]			Distance from End of Shaft [mm]		
						10	20	
Ezi-SPEED-MR-104-H-400-C-R5-H	5	5.5	4.0	10~800	4.2	1,230	1,070	800
Ezi-SPEED-MR-104-H-400-C-R10-H	10	11.1	8.1	5~400				
Ezi-SPEED-MR-104-H-400-C-R15-H	15	16.6	12.1	3.3~266.7		1,680	1,470	
Ezi-SPEED-MR-104-H-400-C-R20-H	20	22.1	16.2	2.5~200				
Ezi-SPEED-MR-104-H-400-C-R30-H	30	33.2	24.2	1.7~133.3		2,040	1,780	
Ezi-SPEED-MR-104-H-400-C-R50-H	50	55.3	40.4	1~80				
Ezi-SPEED-MR-104-H-400-C-R100-H	100	110	80.8	0.5~40				

## ● Dimensions of Motor with Parallel Shaft Gearbox [mm]

# 30<sub>w</sub>

Unit Part Number	Gearbox Part Number	□ Gear Ratio	Mounting Bolt	L [mm]
Ezi-SPEED-MR-60-H-30-C-R□-P	ESG-60-H-R□-P	5, 10, 15, 20	M4×50	34
		30, 50, 100	M4×55	38
		200	M4×60	43

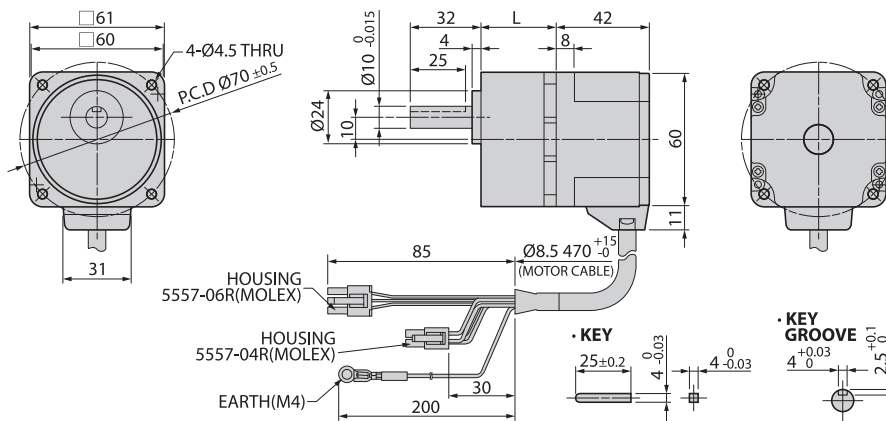

# 60<sub>w</sub>

Unit Part Number	Gearbox Part Number	□ Gear Ratio	Mounting Bolt	L [mm]
Ezi-SPEED-MR-80-H-60-C-R□-P	ESG-80-H-R□-P	5, 10, 15, 20	M4×65	41
		30, 50, 100	M4×70	46
		200	M4×75	51

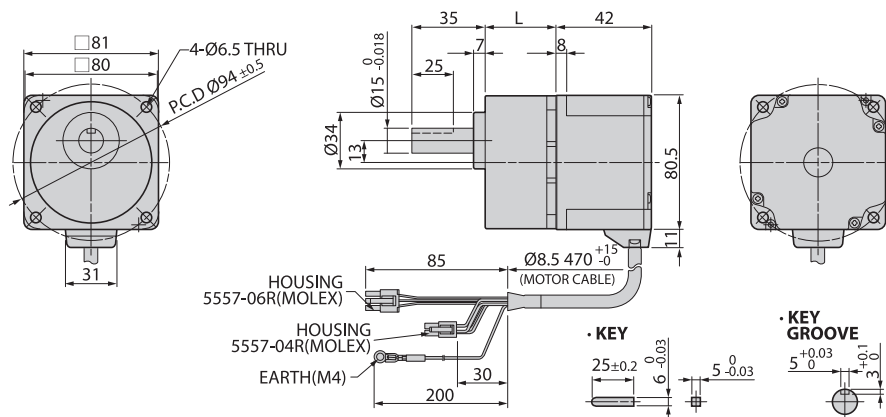

## ● Dimensions of Motor with Parallel Shaft Gearbox [mm]

# 120<sub>w</sub>

Unit Part Number	Gearbox Part Number	□ Gear Ratio	Mounting Bolt	L [mm]
Ezi-SPEED-MR-90-H-120-C-R□-P	ESG-90-H-R□-P	5, 10, 15, 20	M8×75	45
		30, 50, 100	M8×90	58
		200	M8×95	64

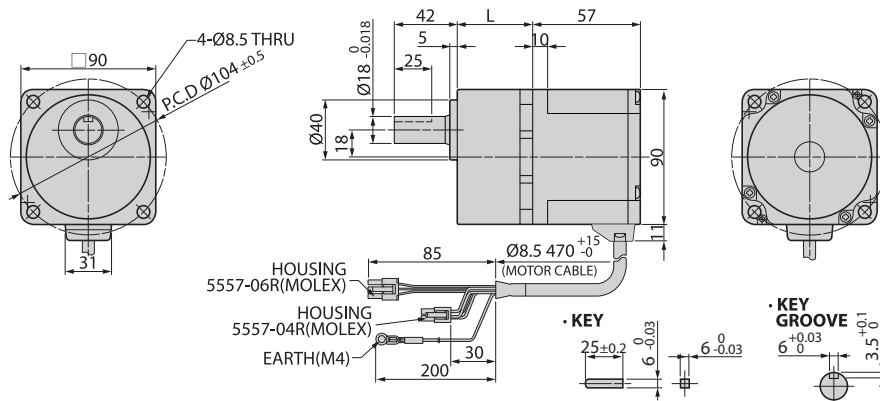

# 200<sub>w</sub>

Unit Part Number	Gearbox Part Number	□ Gear Ratio	Mounting Bolt	L [mm]
Ezi-SPEED-MR-104-H-200-C-R□-P	ESG-104-H-R□-P	5, 10, 15, 20	M8×95	60
		30, 50	M8×110	72
		100, 200	M8×120	86

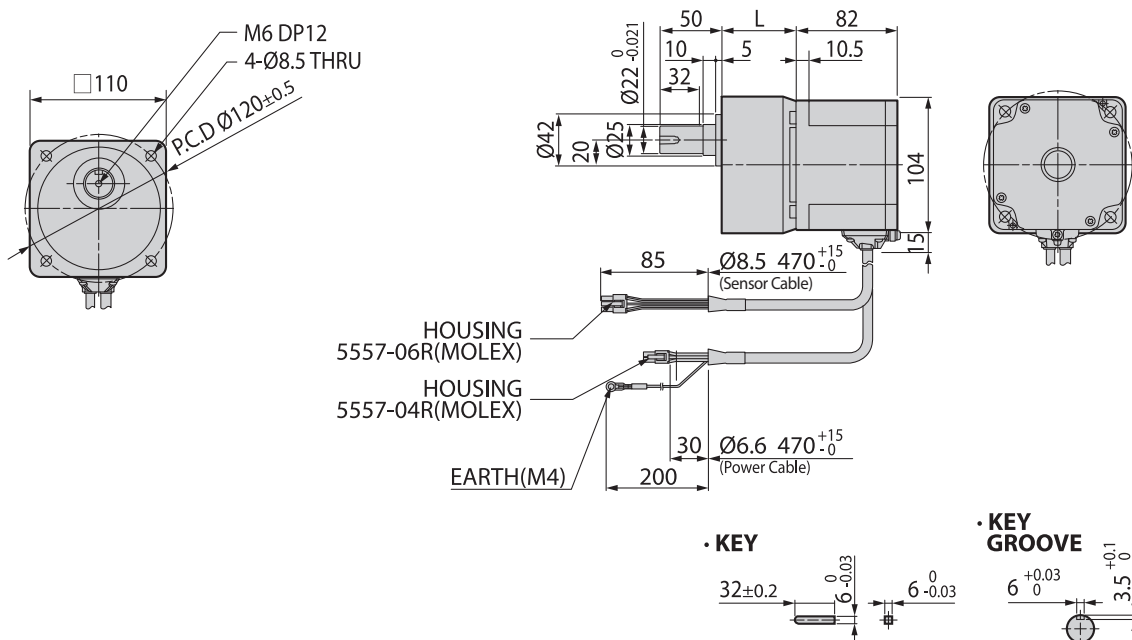

## ● Dimensions of Motor with Parallel Shaft Gearbox [mm]

# 400<sub>w</sub>

Unit Part Number	Gearbox Part Number	□ Gear Ratio	Mounting Bolt	L [mm]
Ezi-SPEED-MR-104-H-400-C-R□-P	ESG-104-H-R□-P	5, 10, 15, 20	M8×95	60
		30, 50	M8×110	72
		100, 200	M8×120	86

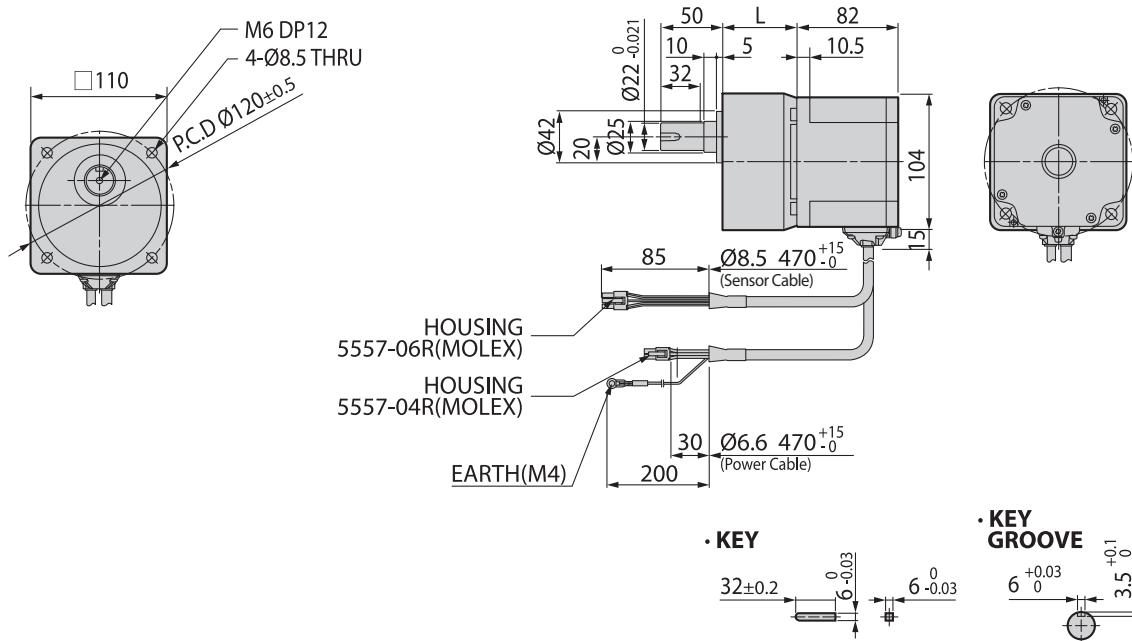

● Dimensions of Motor with Hollow Shaft Gearbox [mm]

# 30<sub>w</sub>

Unit Part Number	Gearbox Part Number	□ Gear Ratio	Mounting Bolt
Ezi-SPEED-MR-60-H-30-C-R□-H	ESG-60-H-R□-H	5, 10, 15, 20, 30, 50, 100, 200	M5×65

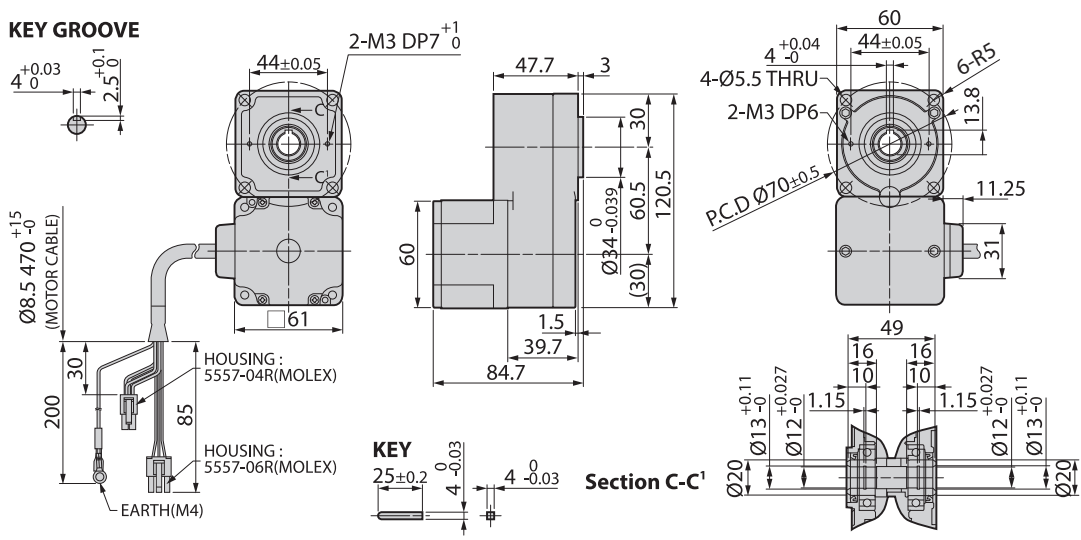

# 60<sub>w</sub>

Unit Part Number	Gearbox Part Number	□ Gear Ratio	Mounting Bolt
Ezi-SPEED-MR-80-H-60-C-R□-H	ESG-80-H-R□-H	5, 10, 15, 20, 30, 50, 100, 200	M6×70

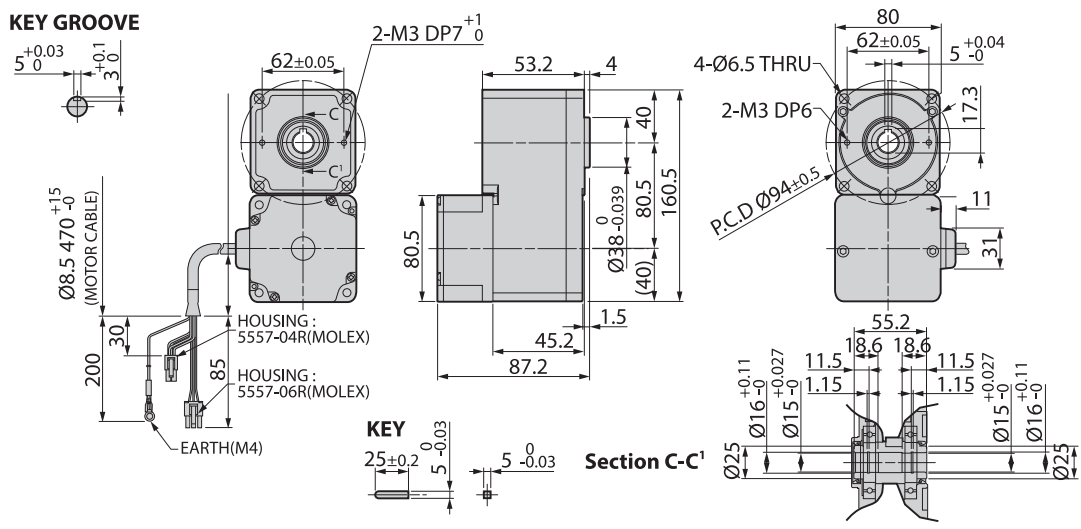

FASTECH Ezi-SPEED Modbus-RTU

## ● Dimensions of Motor with Hollow Shaft Gearbox [mm]

# 120<sub>w</sub>

Unit Part Number	Gearbox Part Number	□ Gear Ratio	Mounting Bolt
Ezi-SPEED-MR-90-H-120-C-R□-H	ESG-90-H-R□-H	5, 10, 15, 20, 30, 50, 100, 200	M8×90

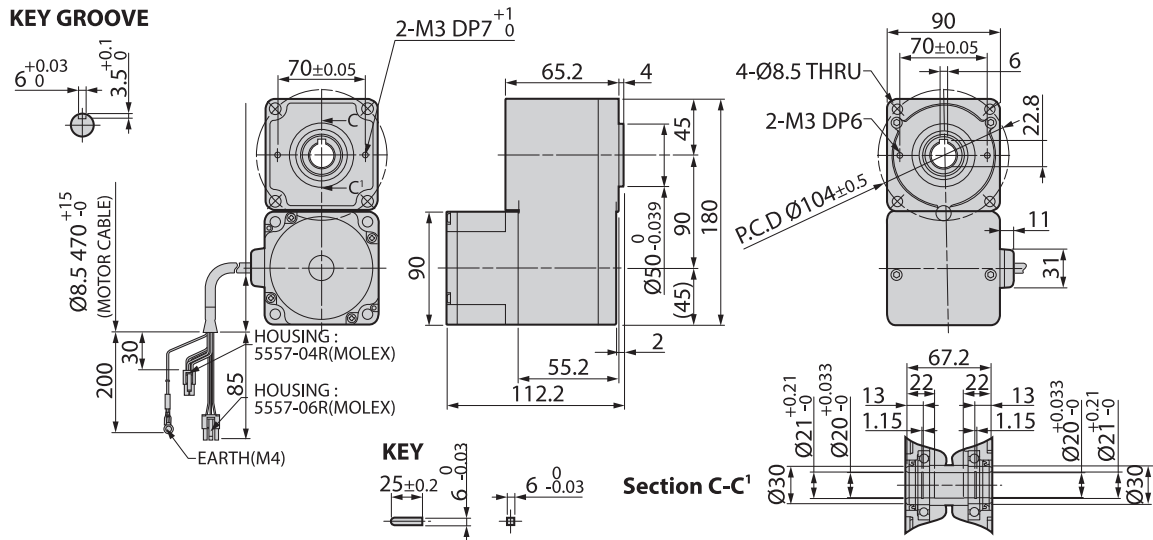

# 200<sub>w</sub>

Unit Part Number	Gearbox Part Number	□ Gear Ratio	Mounting Bolt
Ezi-SPEED-MR-104-H-200-C-R□-H	ESG-104-H-R□-H	5, 10, 15, 20, 30, 50, 100	M8×90

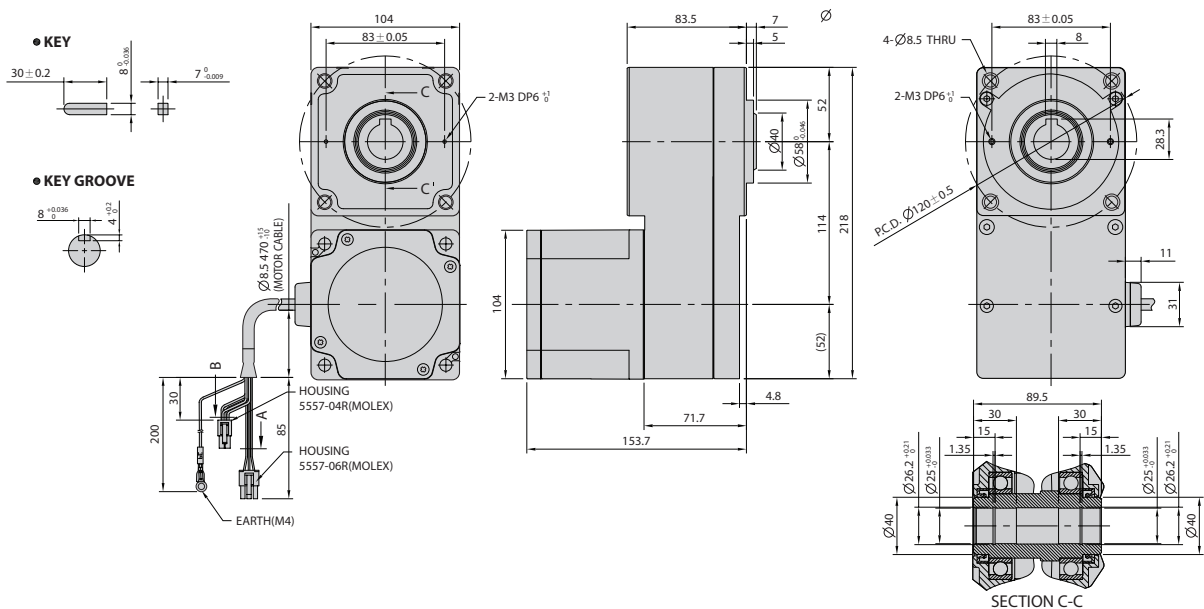



# ● Dimensions of Motor with Hollow Shaft Gearbox [mm]

## 400<sub>w</sub>

Unit Part Number	Gearbox Part Number	□ Gear Ratio	Mounting Bolt
Ezi-SPEED-MR-104-H-400-C-R□-H	ESG-104-H-R□-H	5, 10, 15, 20, 30, 50, 100	M8×90

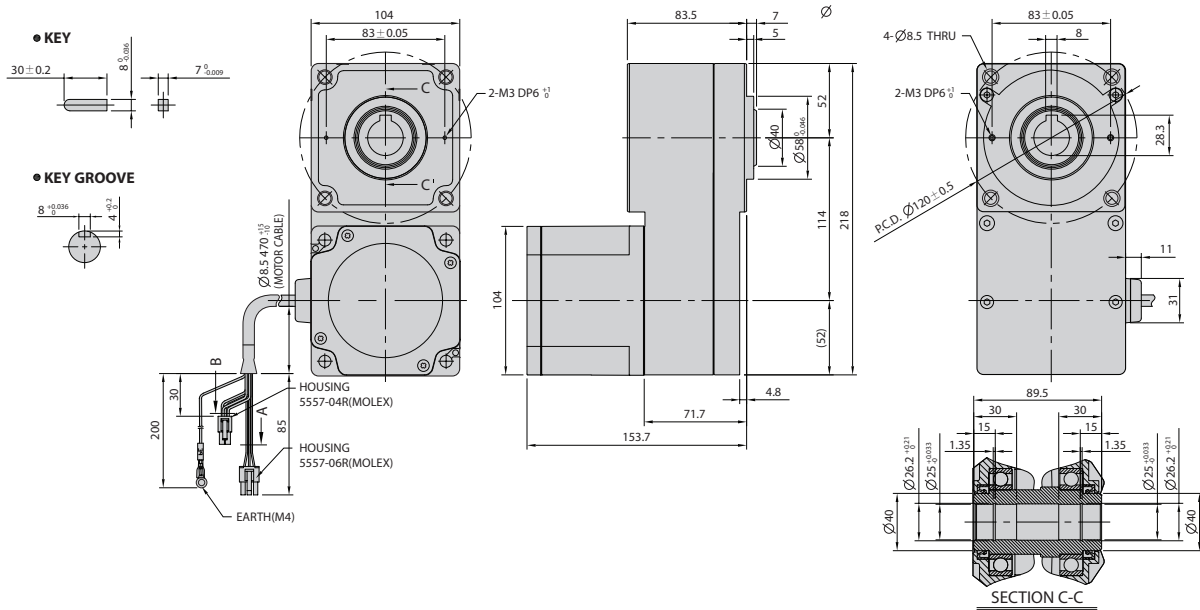

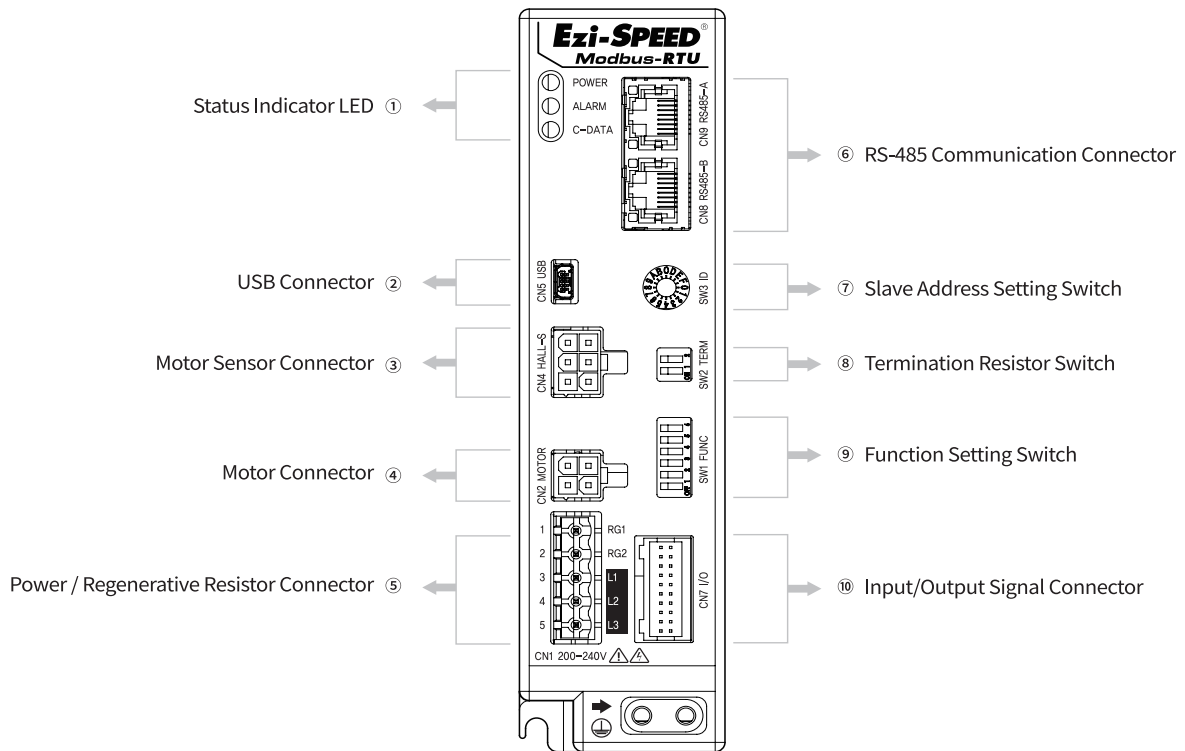

## 1. Name and Function of Parts

No.	Name	Function
①	Status Indicator LED	Indicates the status of the drive.
②	USB Connector (CN5)	Connects the drive to a PC.
③	Motor Sensor Connector (CN4)	Connects the motor sensor.
④	Motor Connector (CN2)	Connects the motor power.
⑤	Power / Regenerative Resistor Connector (CN1)	Connects the main power supply and the regenerative resistor.
⑥	RS-485 Communication Connector (CN8/CN9)	Connects the RS-485 communication.
⑦	Slave Address Setting Switch (SW3)	Sets the network slave address. Max. 31 address can be set via combination with switch No.4 of Function Setting Switch(SW1).
⑧	Termination Resistor Switch (SW2)	Sets the termination resistor.
⑨	Function Setting Switch (SW1)	Sets the baudrate and additional functions.
⑩	Input/Output Signal Connector (CN7)	Connects input/output signals.

## 2. Status Indicator LED

Indication	Color	Function	Description
PowerLED	Green	Power Status	Lights up when power is applied.
ErrorLED	Red	Error Status	Flashes when an error occurs.
Communication LED	Yellow	RS-485 Comm. Status	Flashes when the drive and the master communicate with RS-485.

### • List of Error Types by the Number of LED Blinking

No.	Error Type	Causes
1	Overcurrent	The current through power devices in drive exceeds the limit.
2	Overspeed	The motor speed exceeds 4,400 r/min.
5	Overtemperature	Internal temperature of the drive exceeds 85°C.
6	Overvoltage	· Power voltage exceeds the rated voltage by more than 20%. · Load with large inertia is suddenly started or stopped.
8	Sensor Error	There is a problem with the connection between the drive and the motor sensor.
9	Undervoltage	Power voltage is 40% lower than the rated voltage.
11	Internal Circuit Error	There is a problem in the internal circuit board.
12	EEPROM Error	The stored data is damaged or the read/write of the EEPROM is failed.
16	External Error	EXT-Error input signal is received.
17	Initial Operation Inhibition	Power is applied while FWD or REV input is on, and 'No Operation at Initial Run' parameter is set to 1.
18	RS-485 Comm. Error	The number of RS-485 comm. errors reaches the value set in the 'comm error alarm' parameter.
19	RS-485 Comm. Time Out	Communication is not established for the time set in 'comm time out' parameter.

## 3. Power / Regenerative Resistor Connector(CN1)

No.	Function
1	Regenerative Resistor Connection (RG1)
2	Regenerative Resistor Connection (RG2)
3	Power Input (L1)
4	Power Input (L2)
5	Power Input (L3)

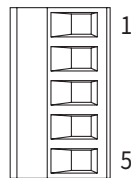

- \* Use RG1, RG2 terminals when connecting a regenerative resistor. A regenerative resistor can be used when the deceleration time is short or the load with large inertia is applied.
- \* Please refer to the manual for details of regenerative resistor specifications.

### • Connection Method

Single-Phase: 200-240V

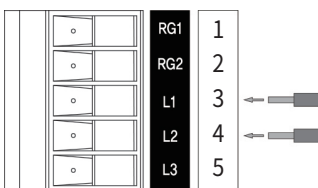

Three-Phase: 200-240V

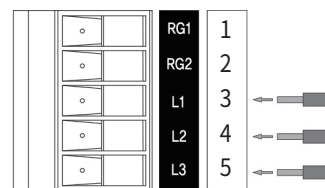

Regenerative Resistor



### • Wire Specifications

AWG18~14 (0.75~2.0mm<sup>2</sup>)

#### 4. Motor Connector(CN2)

No.	Function	I/O
1	-	-
2	BLDC_U	Output
3	BLDC_W	Output
4	BLDC_V	Output

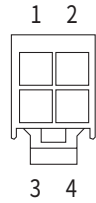

#### 5. Motor Sensor Connector(CN4)

No.	Function	I/O
1	DC5V	Output
2	GND	Common
3	GND	Common
4	HALL_U	Input
5	HALL_V	Input
6	HALL_W	Input

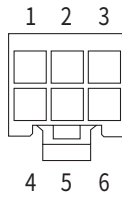

#### 6. USB Connector(CN5)

No.	Function
1	VBUS
2	D-
3	D+
4	-
5	GND

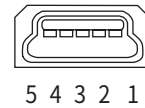

##### • Specifications

Standard USB Cable(USB 2.0 Mini Type B)

#### 7. Input/Output Signal Connector(CN7)

No.	Function	I/O
1	HCOM	Input
2	IN0	Input
3	IN1	Input
4	IN2	Input
5	IN3	Input
6	IN4	Input
7	IN5	Input
8	IN6	Input
9	LCOM	Common
10	OUT0+	Output
11	OUT0-	Output
12	OUT1+	Output
13	OUT1-	Output
14	VH	Input
15	VM	Input
16	VL	Input
17	-	-
18	-	-
19	-	-
20	-	-

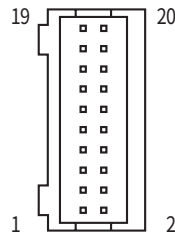

#### 8. RS-485 Communication Connector(CN8, CN9)

No.	Function	No.	Function
1	GND	5	GND
2	GND	6	Data-
3	Data+	7	GND
4	GND	8	GND

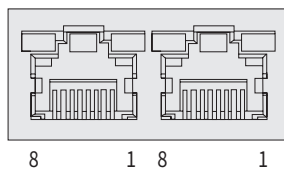

# System Configuration [30, 60, 120W]

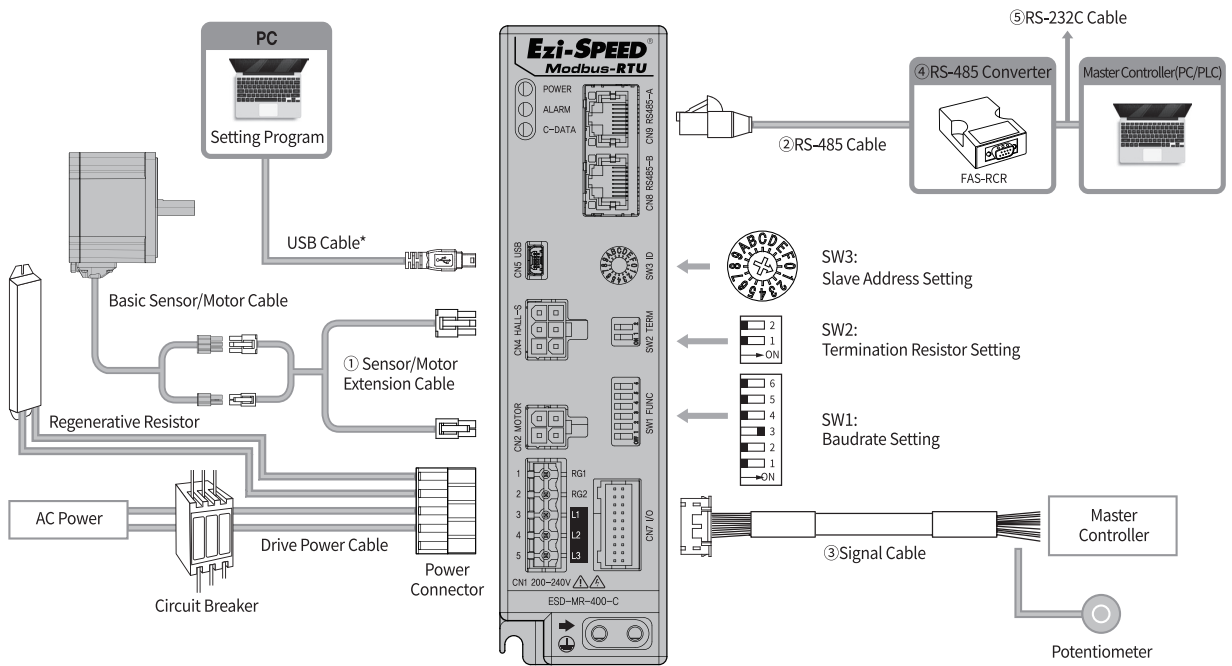

Cable Type	Max. Length	Remarks
① Sensor/Motor Extension Cable	10m	Options (Sold separately)
② RS-485 Cable	30m	
③ Signal Cable	20m	
⑤ RS-232C Cable	5m	
Sensor/Motor Cable	0.3m	Basic cables are attached to motors.
Drive Power Cable	3m	This cable is not provided by FASTECH.
USB Cable	5m	* USB cables are not provided by FASTECH. We recommend using a standard USB cable(USB 2.0 Mini Type B).

## 1. Accessories

### Connectors

These are connector specifications for drive cabling.

Purpose		Item	Part Number	Manufacturer
Power (CN1)		Terminal Block	CPF5.08-05P	STELVIO
Motor (CN2)	Drive Side (CN2)	Housing	5557-04R	MOLEX
		Terminal	5556T	
	Motor Side	Housing	5559-04P	MOLEX
		Terminal	5558T	
Sensor (CN4)	Drive Side (CN4)	Housing	5557-06R	MOLEX
		Terminal	5556T	
	Sensor Side	Housing	5559-06P	MOLEX
		Terminal	5558T	
Signal(CN7)		Housing	PADP-20V-1S	JST
		Terminal	SPH-002T-P0.5L	

## 2. Options

### ① Sensor/Motor Extension Cable

These are the cables to connect the drive for 30W, 60W and 120W to a sensor and a motor.

Purpose	Part Number	Length [m]	Cable Type	Remarks
Drive - Basic Sensor/Motor Cable Connection	CSPD-A-001F	1	Normal Cable	Max. Length : 10m
	CSPD-A-002F	2		
	CSPD-A-003F	3		
	CSPD-A-005F	5		
	CSPD-A-007F	7		
	CSPD-A-010F	10		

### ② RS-485 Cable

These are the cables to connect the drive and the RS-485 master or the RS-485 converter.

Purpose	Part Number	Length [m]	Cable Type	Remarks
RS-485 Connection	CGNR-R-0R6F	0.6	Normal Cable	Max. Length : 30m
	CGNR-R-001F	1		
	CGNR-R-1R5F	1.5		
	CGNR-R-002F	2		
	CGNR-R-003F	3		
	CGNR-R-005F	5		

\* If you need cables with length(in units of 1m) not listed on the table, please contact FASTECH for more information.

### ③ Signal Cable

These are the cables to connect the drive and other input/output devices.

Purpose	Part Number	Length [m]	Cable Type	Remarks
Drive - I/O Device Connection	CSPD-IO-0R6F	0.6	Normal Cable	Max. Length: 20m
	CSPD-IO-001F	1		
	CSPD-IO-002F	2		
	CSPD-IO-003F	3		
	CSPD-IO-005F	5		
	CSPD-IO-007F	7		
	CSPD-IO-010F	10		
	CSPD-IO-015F	15		
	CSPD-IO-020F	20		

### ④ RS-485 Converter

This is a bi-directional converter that converts RS-232C to RS-485 and RS-485 to RS-232C.

Purpose	Part Number	Specifications	Product Image	
RS-232C to RS-485 Converter	FAS-RCR	Baudrate	Max. 115.2 kbps	
		Comm. Distance	RS-232C: Max. 15m RS-485: Max. 1.2km	
		Connector	RS-232C: DB9 Female RS-485: RJ-45	
		Dimensions	50X75X23 mm	
		Weight	38g	
		Power	Power supplied by RS-232C (DC5~24V external power can be applied)	

FASTECH Ezi-SPEED Modbus-RTU

### ⑤ RS-232C Cable

These are the cables to connect RS-485 converter(FAS-RCR) and RS-232C port of the master controller.

Purpose	Part Number	Length [m]	Cable Type	Remarks
FAS-RCR to Master Controller Connection	CGNR-C-002F	2	Normal Cable	Max. Length: 5m
	CGNR-C-003F	3		
	CGNR-C-005F	5		

### ⑥ Regenerative Resistor

It is used to prevent overvoltage alarms when driving a load with a short deceleration time or a large inertia.

Purpose	Part Number	Specifications	Product Image	
Regenerative Resistor	BRM-A100W-400J	Resistance	400 Ω	
		Capacity	100 W	
		Cable Length	30 cm	

# System Configuration [200, 400W]

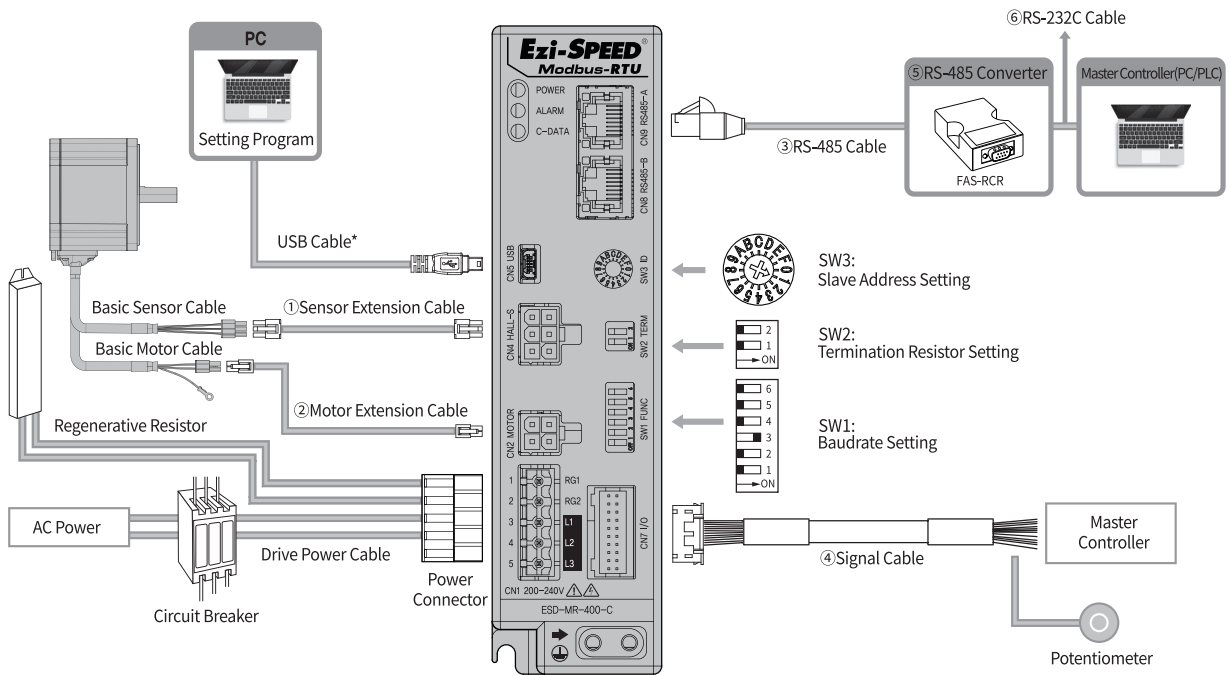

Cable	Max. Length	Remarks
① Sensor Extension Cable	10m	Options
② Motor Extension Cable	10m	
③ RS-485 Cable	30m	
④ Signal Cable	20m	
⑥ RS-232C Cable	5m	
Sensor Cable	0.3m	
Motor Cable	0.3m	
Drive Power Cable	3m	This cable is not provided by FASTECH.
USB Cable	5m	* USB cables are not provided by FASTECH. We recommend using a standard USB cable(USB 2.0 Mini Type B).



## 1. Accessories

### Connectors

These are connector specifications for drive cabling.

Purpose		Item	Part Number	Manufacturer
Power (CN1)		Terminal Block	CPF5.08-05P	STELVIO
Motor (CN2)	Drive Side (CN2)	Housing	5557-04R	MOLEX
		Terminal	5556T	
	Motor Side	Housing	5559-04P	MOLEX
		Terminal	5558T	
Sensor (CN4)	Drive Side (CN4)	Housing	5557-06R	MOLEX
		Terminal	5556T	
	Sensor Side	Housing	5559-06P	MOLEX
		Terminal	5558T	
Signal (CN7)		Housing	PADP-20V-1S	JST
		Terminal	SPH-002T-P0.5L	

## 2. Options

### ① Sensor Extension Cable

These are the cables to connect the drive for 200W and 400W to a sensor.

Purpose	Part Number	Length[m]	Cable Type	Remarks
Drive - Basic Sensor Cable Connection	CSPD-S-001F	1	Normal Cable	Max. Length : 10m
	CSPD-S-002F	2		
	CSPD-S-003F	3		
	CSPD-S-005F	5		
	CSPD-S-007F	7		
	CSPD-S-010F	10		

### ② Motor Extension Cable

These are the cables to connect the drive for 200W and 400W to a motor.

Purpose	Part Number	Length[m]	Cable Type	Remarks
Drive - Basic Motor Cable Connection	CSPD-M-001F	1	Normal Cable	Max. Length : 10m
	CSPD-M-002F	2		
	CSPD-M-003F	3		
	CSPD-M-005F	5		
	CSPD-M-007F	7		
	CSPD-M-010F	10		

### ③ RS-485 Cable

These are the cables to connect the drive and the RS-485 master or the RS-485 converter.

Purpose	Part Number	Length [m]	Cable Type	Remarks
RS-485 Connection	CGNR-R-0R6F	0.6	Normal Cable	Max. Length: 30m
	CGNR-R-001F	1		
	CGNR-R-1R5F	1.5		
	CGNR-R-002F	2		
	CGNR-R-003F	3		
	CGNR-R-005F	5		

\* If you need cables with length(in units of 1m) not listed on the table, please contact FASTECH for more information.

### ④ Signal Cable

These are the cables to connect the drive and other input/output devices.

Purpose	Part Number	Length [m]	Cable Type	Remarks
Drive - I/O Device Connection	CSPD-IO-0R6F	0.6	Normal Cable	Max. Length: 20m
	CSPD-IO-001F	1		
	CSPD-IO-002F	2		
	CSPD-IO-003F	3		
	CSPD-IO-005F	5		
	CSPD-IO-007F	7		
	CSPD-IO-010F	10		
	CSPD-IO-015F	15		
	CSPD-IO-020F	20		

### ⑤ RS-485 Converter

This is a bi-directional converter that converts RS-232C to RS-485 and RS-485 to RS-232C.

Purpose	Part Number	Specifications	Product Image
RS-232C to RS-485 Converter	FAS-RCR	Baudrate	Max. 115.2 kbps
		Comm. Distance	RS-232C: Max. 15m RS-485: Max. 1.2km
		Connector	RS-232C: DB9 Female RS-485: RJ-45
		Dimensions	50X75X23 mm
		Weight	38g
		Power	Power supplied by RS-232C (DC5~24V external power can be applied)



### ⑥ RS-232C Cable

These are the cables to connect RS-485 converter(FAS-RCR) and RS-232C port of the master controller.

Purpose	Part Number	Length [m]	Cable Type	Remarks
FAS-RCR to Master Controller Connection	CGNR-C-002F	2	Normal Cable	Max. Length: 5m
	CGNR-C-003F	3		
	CGNR-C-005F	5		

### ⑦ Regenerative Resistor

It is used to prevent overvoltage alarms when driving a load with a short deceleration time or a large inertia.

Purpose	Part Number	Specifications		Product Image
Regenerative Resistor	BRM-A100W-400J	Resistance	400 $\Omega$	
		Capacity	100 W	
		Cable Length	30 cm	

## Ezi-SPEED Modbus-RTU

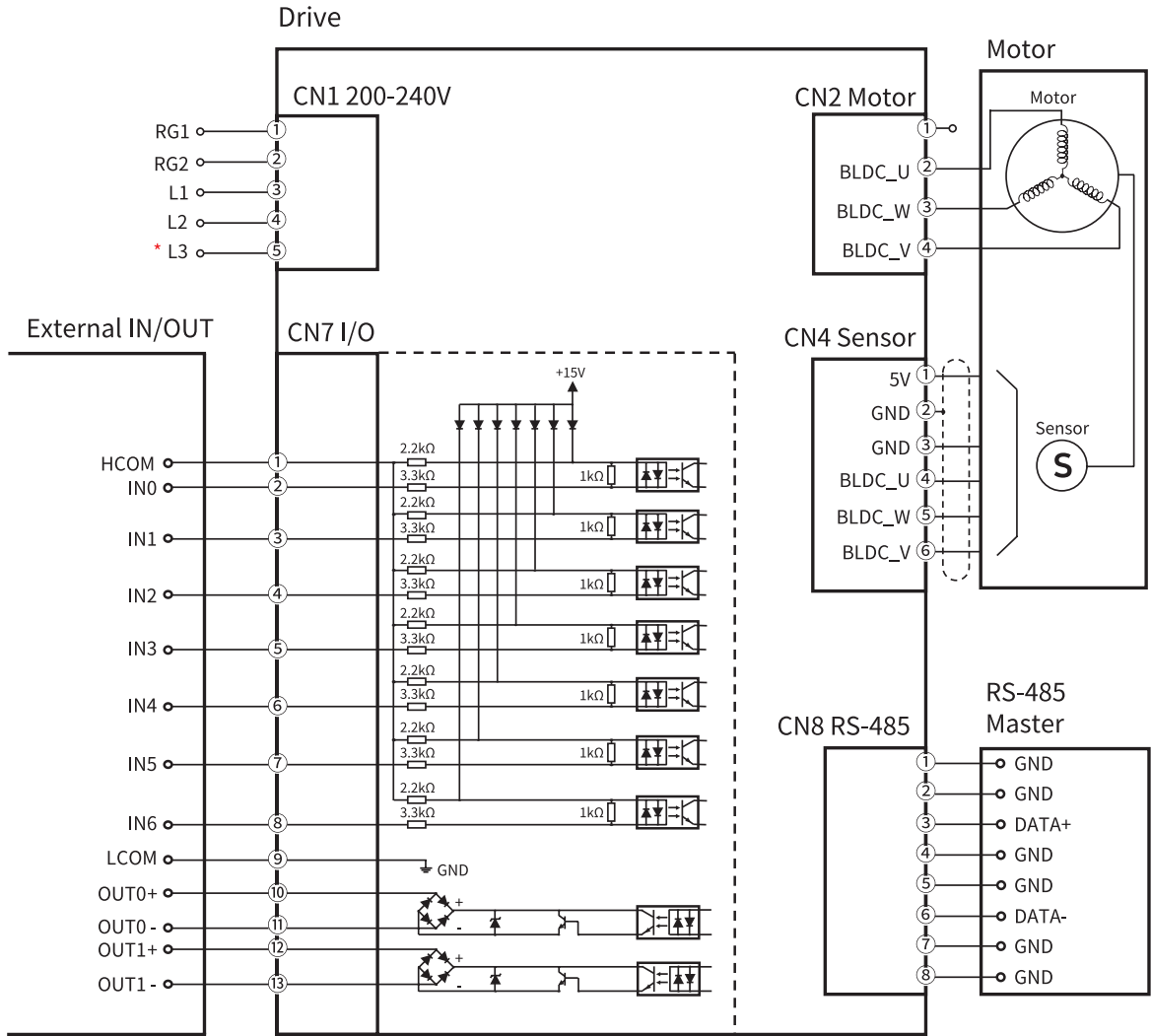

FASTECH Ezi-SPEED Modbus-RTU

\* Connects when using three-phase.

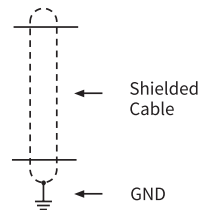

### CAUTION

In order to use the products listed in this catalog safely and correctly, be sure to read the instruction manual before using the product.

※ When connecting I/O cable between controller and drive, please turn off the power of both controller and drive to prevent electric shock or to protect the drive from any damage.

# Ezi-SPEED Setting Program

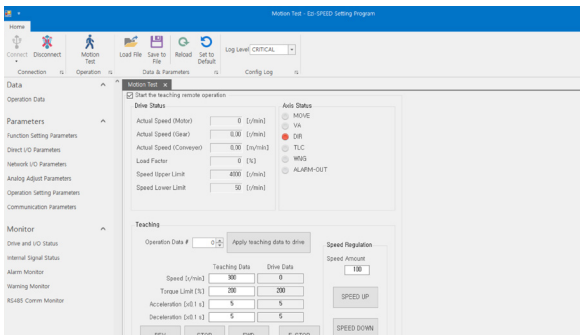

## ◆ Motion Test

With simple settings, you can easily check whether the drive and motor are operating correctly, and you can conveniently set the data values.

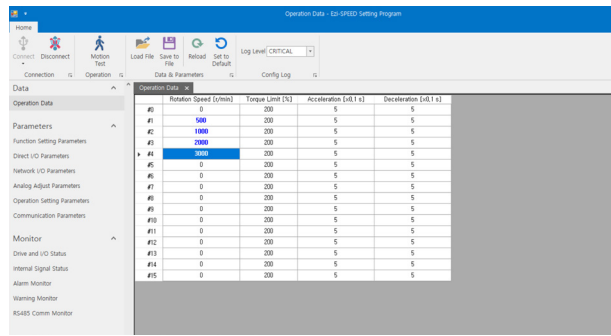

## ◆ Operation Data Setting

Operation data consists of the necessary data for operating the motor, including rotation speed, acceleration time, deceleration time, and torque limit. You can set up to 16 sets of operation data.

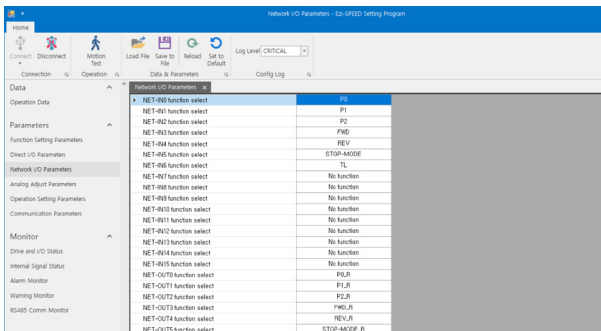

## ◆ Parameter List

You can change and save all parameters.

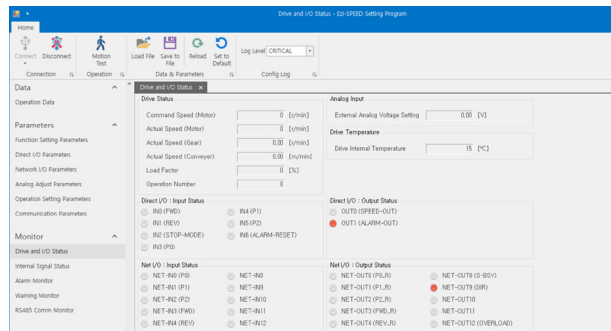

## ◆ Drive and I/O Status Monitor

You can check the input and output status connected to the drive. You can also monitor internal conditions such as motor speed and drive temperature.

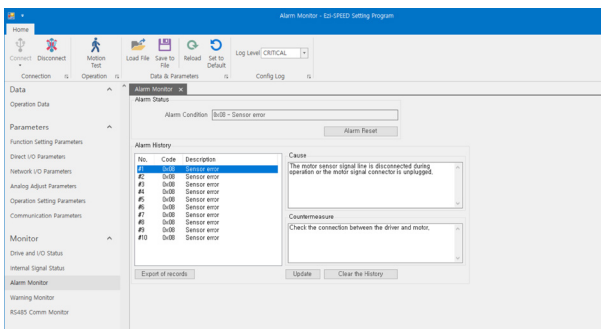

## ◆ Error, Warning, and Comm. Error Monitor

The current status, past history, causes of error, and countermeasures are displayed. There is also an alarm reset button for releasing alarms.

- ※ Ezi-SPEED Setting program can be downloaded from the website ([www.fastech-motions.com](http://www.fastech-motions.com)).
- ※ Ezi-SPEED Setting program supports Windows 7/8/10.
- ※ Ezi-SPEED Setting program may change without notice for performance improvement.

# MEMO



*Fast, Accurate, Smooth Motion*

**FASTECH Co., Ltd.**

(Postal Code:14502) Rm#1202, 401-dong, Bucheon  
Techno-Park, 655, Pyeongcheon-ro Bucheon-si  
Gyeonggi-do, Republic of Korea  
TEL : +82-32-234-6317 FAX : +82-32-234-6302  
E-mail : sales@fastech-motions.com  
Homepage : www.fastech-motions.com