

In-Vacuum Stepper Motors Cryo Motors

How to Handle



**How to Handle
In-Vacuum Stepper Motors
and Cryo Stepper Motors**

How to Handle In-Vacuum and Cryo Stepper Motors

Version	Modification
11	Technical data
12	Transport package
13	Gloves out of delivery

© 2021

All rights with:

Phytron GmbH

Industriestraße 12

82194 Gröbenzell, Germany

Tel.: +49(0)8142/503-0

Fax: +49(0)8142/503-190

Every possible care has been taken to ensure the accuracy of this technical manual. All information contained in this manual is correct to the best of our knowledge and belief but cannot be guaranteed. Furthermore, we reserve the right to make improvements and enhancements to the manual and / or the devices described herein without prior notification.

We appreciate suggestions and criticisms for further improvement. Please send your comments to the following

E-mail address: doku@phytron.de

Contents

1	Legal Information	4
1.1	Qualified personnel	5
1.2	Safety Instructions	6
1.3	Handling instruction	7
1.4	European Standards and CE Mark	8
2	In-Vacuum Stepper Motors and Cryo Stepper Motors.....	9
2.1	Heating in Vacuum Environment.....	9
3	Package.....	10
3.1	Transport Package.....	10
3.2	Outer Package.....	10
3.3	Protective Film	11
3.4	Rating Plate	12
4	Configuration and Use Limitation	13
4.1	Motor Selection	13
4.2	Use limitation	14
5	Mounting.....	15
6	Electrical Connection	16
6.1	Maximum Allowable Phase Current	18
6.2	Leads.....	19
6.2.1	Marking of the Leads.....	19
6.2.2	Connecting the Leads	20
6.3	Direction of Rotation	21
7	Temperature Measuring (Motors with Temperature Sensor)	22
7.1	Type K Thermal Element	22
7.2	Pt100 Resistor Sensor	23
8	Conditioning In-Vacuum Stepper Motors.....	25
8.1	Overview.....	25
8.2	Baking Out (Option)	25
8.3	First Outgassing (Standard)	25
8.4	Degas (Option)	25
9	Storage.....	26
10	Technical Data.....	27
10.1	Vacuum Classes.....	27
10.2	Design Voltage	27
10.3	Test Voltage.....	27
11	Declaration of Incorporation	28

How to Handle In-Vacuum and Cryo Stepper Motors









1 Legal Information



This manual:

Read this manual very carefully before mounting, installing and operating the device and if necessary further manuals related to this product.

- Please pay special attention to instructions that are marked as follows:

	DANGER – Serious injury!	<i>Indicates a high risk of serious injury or death!</i>
	DANGER – Serious injury from electric shock!	<i>Indicates a high risk of serious injury or death from electric shock!</i>
	WARNING – Serious injury possible!	<i>Indicates a possible risk of serious injury or death!</i>
	WARNING – Serious injury from electric shock!	<i>Indicates a possible risk of serious injury or death from electric shock!</i>
	CAUTION – Possible injury!	<i>Indicates a possible risk of personal injury.</i>
	CAUTION – Possible damage!	<i>Indicates a possible risk of damage to equipment.</i>
	CAUTION – Possible damage due to ESD!	<i>Refers to a possible risk of equipment damage from electrostatic discharge.</i>
	”Any heading“	<i>Refers to an important paragraph in the manual.</i>

1.1 Qualified personnel

Observe the following safety instructions!



WARNING – Serious injury possible!

Serious personal injury or serious damage to the machine and drives could be caused by insufficiently trained personnel!

Without proper training and qualifications, damage to devices and injury might result!

- Design, installation and operation of systems may only be performed by qualified and trained personnel.
- These persons should be able to recognize and handle risks emerging from electrical, mechanical or electronic system parts.
- The qualified personnel must know the content of this manual and be able to understand all documents belonging to the product. Safety instructions are to be provided.
- The trained personnel must know all valid standards, regulations and rules for the prevention of accidents, which are necessary for working with the product.

1.2 Safety Instructions



Intended use:

The In-Vacuum and Cryo stepper motors are designed for operating in an in-vacuum drive system.

- An installation is allowed only if the requirements of the EC Machinery and EMC Directives are conformed with.



Part of a machine:

This product is used as a part of a complete system, therefore risk evaluations concerning the specific application must be made before using the product.

- Safety measures have to be taken according to the results and be verified.
- Personnel safety must be ensured by the concept of this overall system (e.g. machine concept).



WARNING – Injury from the rotating shaft!

The rotating motor shaft can accelerate loosely attached parts. This can result in injury.

- Make sure, that before operation, all moving parts are fixed.



WARNING – Injury from the rotating shaft!

Hair, clothes and jewellery can be wound up and trapped by the rotating motor shaft.

- Before starting to wire, make sure that clothing and jewellery are tight and hair cannot be captured.



WARNING – Injury from conversion into a translational motion!

If the rotation in the customer system is converted into a translational motion (e.g. via spindle) injuries can occur from crushing.

- Before operation, check the system structure.



WARNING – Serious injury from electric shock!

During electrical installation cables, connectors, etc. can be live.

- Do not plug or unplug the motor while powered.
- Do not plug or unplug the connectors while powered.
- If the motor was energised, wait 3 minutes after power off to allow the capacitors to discharge and ensure that there are no residual charges on cables, connectors and boards.

**WARNING – Injury from touching the housing!**

Stepper motors heat up during operation. The surface of the motor can be heated over +100 °C.

- The motor must be mounted in such way that proper dissipation of the generated heat is ensured.
- Wait until the stepper motor has completely cooled down.
- Ensure measures for contact protection

1.3 Handling instruction

**CAUTION – Possible damage!**

The stepper motor's rotor is strongly magnetic. Metal or soft iron particles penetrating through the large outgassing holes might damage motor function.

- Metal particles must be kept away from the motor.

**CAUTION – Possible damage!**

Foreign substances, dirt or humidity penetrating through the outgassing holes could seriously damage motor function or cause breakdown.

- Do not touch the stepper motor with bare hands. **Wear security gloves**
- Handle the in-vacuum stepper motor/cryo stepper motor only in a very clean environment!



CAUTION – Possible damage!

- Please note the wiring data on the data plate and the permitted mechanical loads (see technical data in the data sheet).
- Switch off the supply voltage before mounting and wiring the stepper motor.
- Stepper motors must not be operated with mains voltage. Stepper motors require special control units
- While press-fitting couplings or pinions on the motor shaft, the latter should be supported.
- Remove the PTFE tube only from the lead which you are just connecting (chapter 6.2.2).
- Never lift the motor by means of its cables or leads! Care for strain relief when stripping or shortening the leads!
- Comply with EMC conform wiring (chapter 6.2.2).
- Do not open the stepper motor! If the casing is opened, the motor may be damaged. Phytron's warranty does not apply if motors are opened by the customer. **When operating a motor that was assembled improperly, danger to life could be caused by electric shock.**
- The customer must not carry out mechanical or electrical modifications of the motor. The warranty does not apply if the motor is modified by the customer without the manufacturer's permission

1.4 European Standards and CE Mark

When installed appropriately, VSS in-vacuum and Cryo stepper motors fulfil the requirements of the EMC and Low Voltage Directives. VSS in-vacuum and Cryo stepper motors are qualified to be marked CE and comply with EN 60034-1 European Standard.

When wired correctly (see chapter Fig. 4), VSS in-vacuum and Cryo stepper motors fulfil the requirements of the EMC Directive. Information concerning the connection of the motor cable to the control unit or the power stage is given in the corresponding manuals.

According to the European Machine Directive, the stepper motor is only a part of a machine. Placing into operation is not allowed until the machine manufacturer takes appropriate measures to ensure that the entire system fulfils the requirements of the applicable EU Directives.

2 In-Vacuum Stepper Motors and Cryo Stepper Motors

Phytron VSS stepper motors for in-vacuum and Cryo applications are precision drives with protection class IP20. According to the vacuum class, the motors are designed for different temperature, pressure and radiation ranges, see section 10.1. Cryo stepper motors are ultra high vacuum stepper motors for operation e.g. in liquid nitrogen or liquid helium.

In-vacuum and Cryo stepper motors are manufactured, cleaned, tested and packed with great care and accuracy. A 3-stage package protects the stepper motor against contamination, moisture and mechanical damage.

On opening the packaging, several precautions must be observed (section 3) to maintain the defined stepper motor's specifications and functionality.

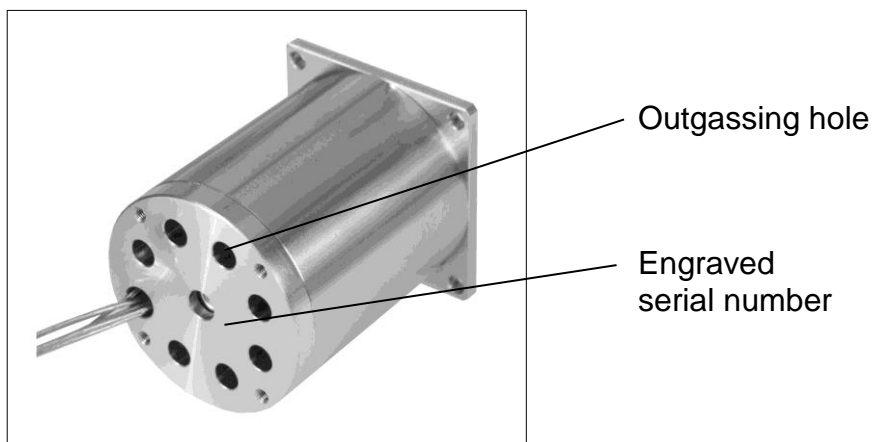

Fig. 1 : In-vacuum or Cryo stepper motor – rear view

i

The two most important rules for handling in-vacuum and Cryo stepper motors:

- Do not touch the stepper motor with bare hands!
- Take care that no particles or moisture can get inside the motor through the outgassing holes.

2.1 Heating in Vacuum Environment

Normally, the heat generated by a stepper motor in a vacuum is largely dissipated by conduction through the mounting surface; heat dissipation by convection and radiation are negligible. To avoid overheating the motor, the maximum specified temperatures (section 10.1) must be taken into account when determining duty cycles for setting the peak, run and stop (holding) current values.

How to Handle In-Vacuum and Cryo Stepper Motors

3 Package

A special 3-stage package – transport package, outer package and protective film keeps the in-vacuum and Cryo stepper motors from contamination, moisture and mechanical damage.

3.1 Transport Package

The type of transport package depends on the motor type, e.g. a cardboard box with moulded foam, bubble wrap or similar material protects the motor during transport.

3.2 Outer Package

The **outer package** is a gas-tight, evacuated foil package with the rating plate fixed. A desiccant bag and the stepper motor are shrink-wrapped in the outer package.



Fig. 2 : Outer packaging with rating plate

i

Outer package:

- Before opening the outer package:
Clean the outer package with a cleaning agent usual in vacuum technology, e.g. IPA.
- Remove outer package just short before mounting the motor.

3.3 Protective Film

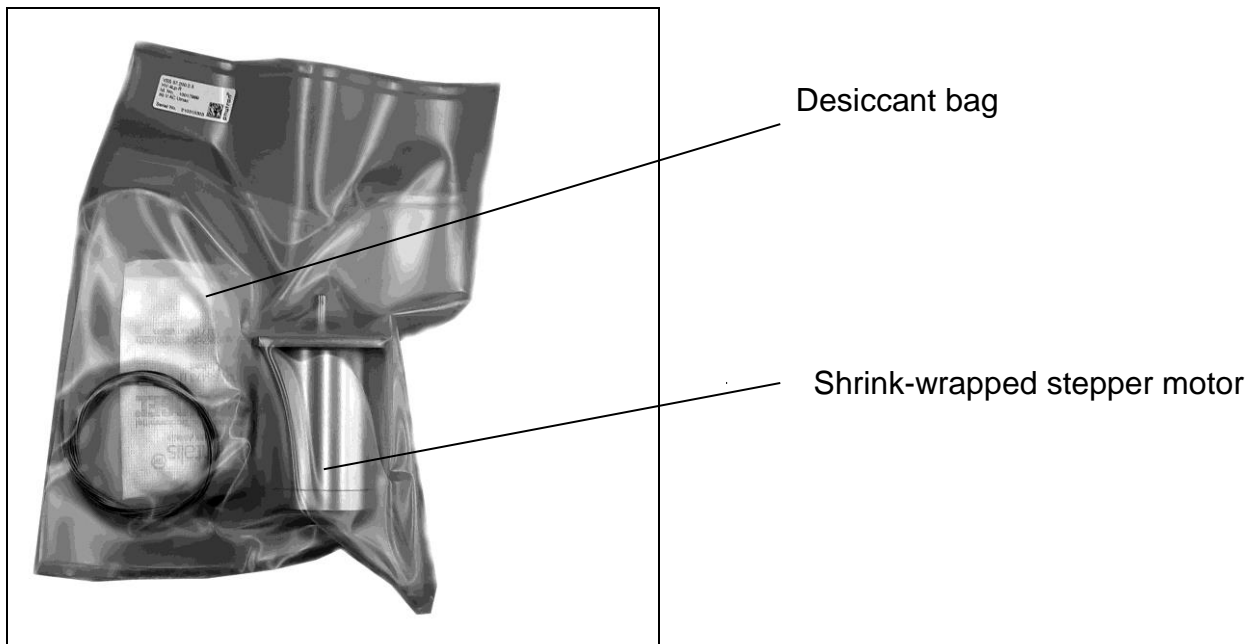

Fig. 3 : Stepper motor, desiccant bag

The stepper motor is shrink-wrapped in evacuated protective film.

i

Do not touch an in-vacuum or Cryo stepper motor with bare hands!

Wearing safety gloves helps to keep away finger sweat and oil residues from the stepper motor. Such residues cannot be completely removed with IPA and may need the motor to be returned to Phytron for cleaning.

- Before opening the protective film: Put on some safety gloves.
- After removing from the foil packaging the stepper motor has to be stored in a clean box, clean room or closed container

3.4 Rating Plate



Rating plate

On the rating plate, you will find important information about the stepper motor.

- Keep the rating plate!
- In-vacuum stepper motors are only minimally marked (a serial number is engraved). Therefore, we recommend to remove the rating plate from the outer packaging and to stick it on the service documents or in the field below.

*Remove the rating plate
from the package
and stick it here!*

Rated current: See explanations in section 6.1.

4 Configuration and Use Limitation

4.1 Motor Selection

Our sales team will assist you with the configuration. The following scheme will help you select the suitable motor:

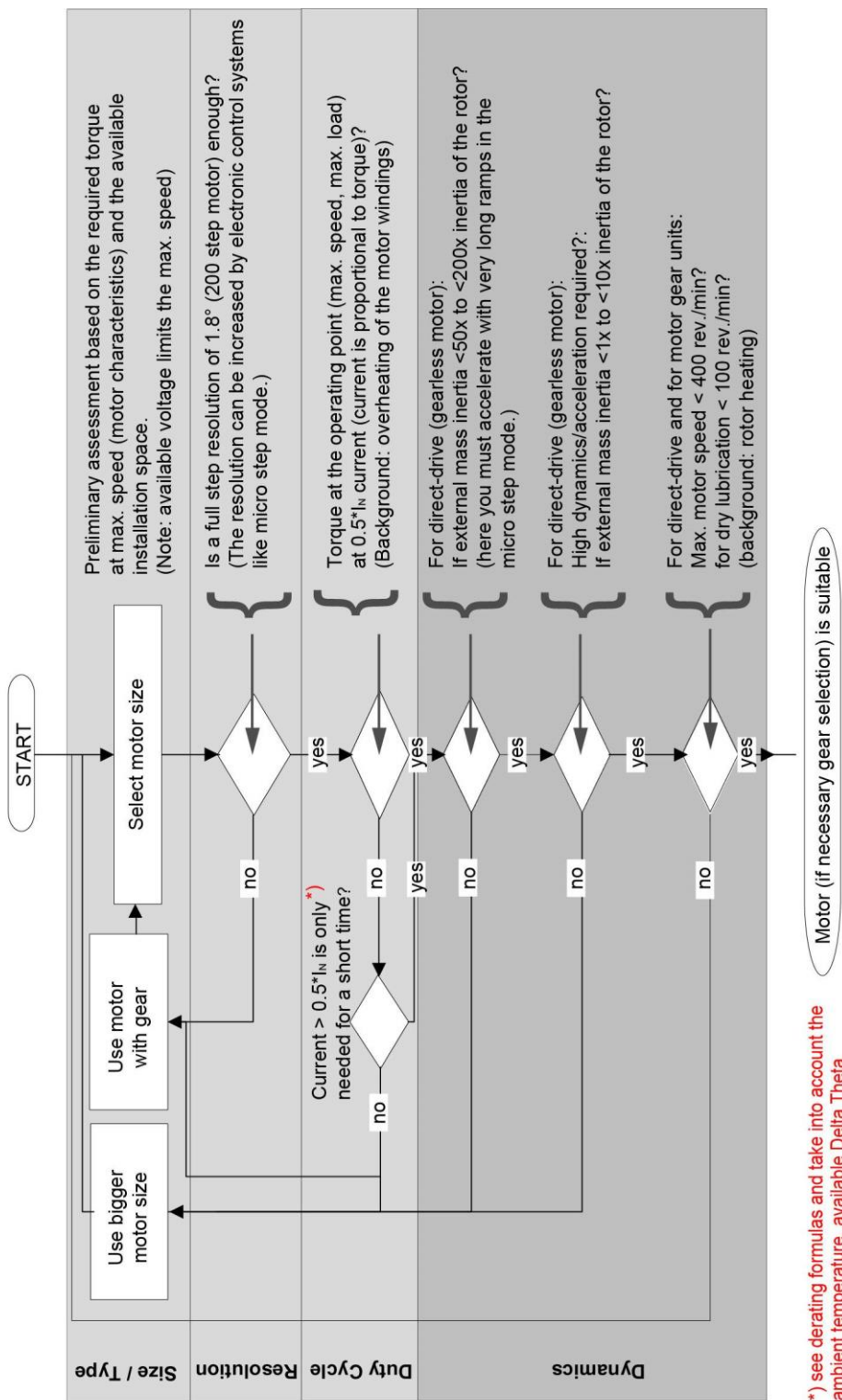

Fig. 4 : Selection of the motor (size/resolution/duty cycle/dynamics)

How to Handle In-Vacuum and Cryo Stepper Motors

4.2 Use limitation

Derating formulas:

Continuous operation without overheating at 400 rev/min max. and $1/2 \cdot I_N$ in vacuum.
Short-term operation with higher current (I_{on}) is possible depending on the duty cycle (ratio t_{on} to t_{off}).

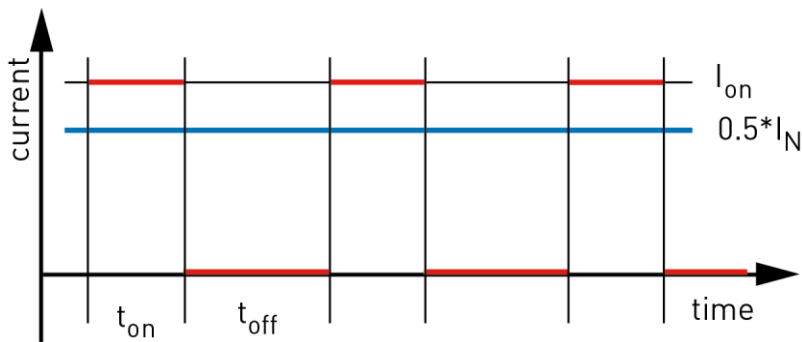

applies to speed ≤ 400 rev./min;

I_N = nominal motor current;

$I_{on} > I_N$: overcurrent

How long may last the switch-on time t_{on} ?

$$t_{on} \leq \frac{\left(\frac{I_N}{2}\right)^2}{I_{on}^2 - \left(\frac{I_N}{2}\right)^2} \times t_{off}$$

How long may last the stop t_{off} ?

$$t_{off} \geq \left(\frac{I_{on}^2}{\left(\frac{I_N}{2}\right)^2} - 1 \right) \times t_{on}$$

What is the maximum current during the I_{on} switch-on phase?

condition: $I_{on} = 1,3 \times I_N$ and $t_{on} \leq 10$ s

$$I_{on} \leq \sqrt{\frac{t_{on} + t_{off}}{t_{on}}} \times I_N$$

5 Mounting



CAUTION – Possible injury!

- Power down the installation area or the stepper motor control unit.



CAUTION – Possible damage!

The stepper motor's rotor is strongly magnetic. Foreign substances, which penetrate through the outgassing holes, could decrease motor function.

- Do not touch the in-vacuum or Cryo stepper motor with bare hands! **Wear safety gloves!**
- Therefore, take care when mounting the motor: metal or soft iron particles must not penetrate through the large outgassing holes into motor or gearing.
- When handling stepper motors with outgassing holes, the environment should be kept very clean. Penetrating foreign substances, dirt or humidity could seriously damage motor function or cause breakdown. **Keep away metal particles from the motor! In-vacuum or Cryo stepper motors should only be handled in a very clean environment.**



CAUTION – Possible damage!

When flanging the motor, axial or radial force effects on the shaft (e.g. strokes) must be avoided. Lifetime of the ball bearings will be shortened by all kinds of load or rough treatment.

- Do not exceed the maximum axial and radial loads!
Avoid high shaft loads, e.g. shock/transient forces. Use suitable couplings.

How to Handle In-Vacuum and Cryo Stepper Motors

6 Electrical Connection

Phytron in-vacuum and Cryo stepper motors are 2-phase stepper motors. The windings can be connected differently. Standard is 4-leads wiring with parallel connected windings for bipolar control mode.

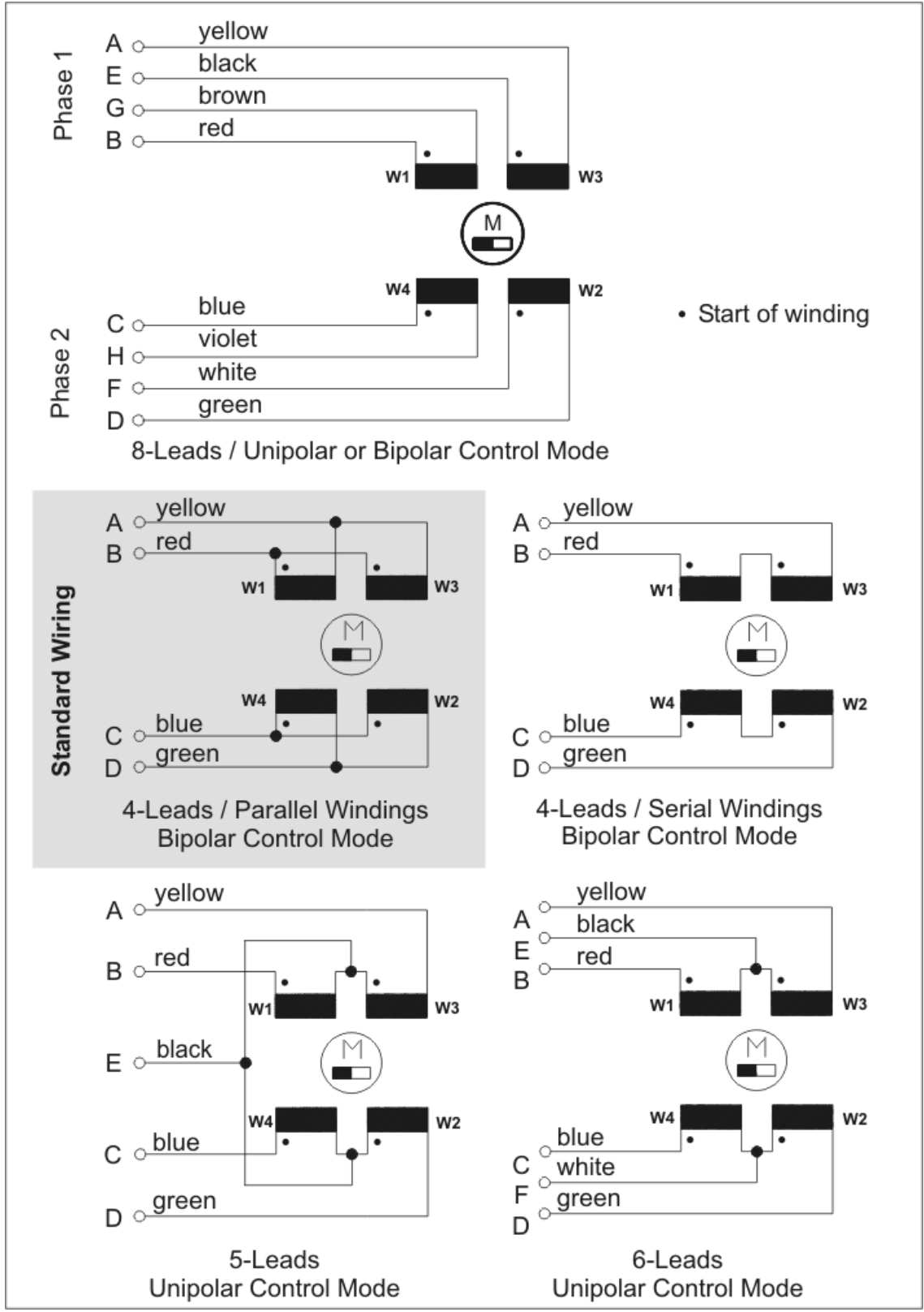

Fig. 5 : Connection schemes for Phytron stepper motors

8-leads stepper motors have two leads from each of the four motor windings (see Fig. 5, upper drawing). These motors can be driven by all types of control units in bipolar and unipolar operating modes.

4-leads stepper motors (windings parallel or serially connected, see Fig. 5, middle) are designed for bipolar operation mode.

5-lead or 6-lead stepper motors (Fig. 5, below) can be driven by unipolar control units.

The **cable cross section** for the connection leads should be selected according to the cable length. Please follow the advice in the stepper motor power stage manual.

i **Bipolar operation mode – parallel or series winding connection**

Low control pulse frequency: When operated with maximum allowable phase current (see table below), with both connection modes the same motor torque is generated.

With rising frequency, the torque drops off sooner with serial windings. Reason: The motor's inductance is four times higher (compared to unipolar operation or bipolar operation with parallel windings).

Operation with low control pulse frequencies

The motor has up to 40 % more torque in the bipolar mode (compared to unipolar control) with the same phase current, at low frequencies.

The **cable cross section** for the connection leads should be selected according to the cable length. Please follow the advice in the stepper motor power stage manual.

.

How to Handle In-Vacuum and Cryo Stepper Motors

6.1 Maximum Allowable Phase Current

The motor rating plate has the rated phase current [A] as the last digits of the motor's type number.

Example: VSS 32.200.1,2 Motor type VSS 32, 200 steps/rev., 1.2 A rated current

The **rated current** is the maximum allowable current at full step operation, at bipolar control mode, with parallel-connected windings (standard).

Maximum Allowable Phase Current			
bipolar control mode full step operation		unipolar control mode full step operation	
4-lead motor parallel windings	4-lead motor serial windings	5-lead motor	6-lead motor
rated current	50% of rated current	70.7% of rated current	70.7% of rated current

The **maximum allowable power dissipation** of a stepper motor is always the same for all connection modes. According to the connection mode, the motor windings receive different currents. Therefore, the maximum allowable phase currents are determined by the connection mode.

At **half-step or mini-step** operation of the control unit, the rated current is the r.m.s value. The current tables in Phytron's power stage manuals show r.m.s. values.

6.2 Leads

6.2.1 Marking of the Leads

HV (high vacuum) and UHV (ultra high vacuum) stepper motor wires are the same colour and are identified by coloured PTFE tubes:

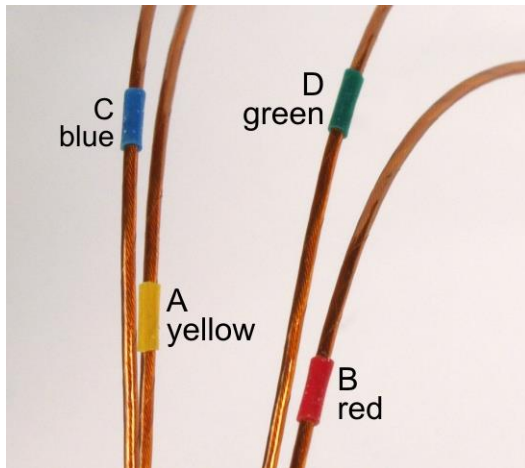

Fig. 6 : Marking of the wires by coloured PTFE tubes

In case of motors with built-in type K thermal elements, the minus pole is magnetic.



HV stepper motors

The tubes can remain on the wires if desired.



UHV stepper motors

- The PTFE tubes can remain on the wires, if the motor is only operated in the temperature range up to +200 °C or 10^4 rad radiation. When temperature or radiation is higher, the tubes have to be removed.
- Before mounting the motor: Do not remove the PTFE tubes! The wires can only be identified by their markings.
- Connecting the wires: Only remove the PTFE tube from the wire being connected. Be careful not to mix up the wires. The start and end of a winding in an 8-lead stepper motor cannot be determined by measurement.
- Recommendation: Keep the PTFE tubes! If disconnecting the stepper motor, the markings should be reattached.

6.2.2 Connecting the Leads



CAUTION – Possible damage!

The leads of the motor:

- The leads from stepper motor to control terminals are not shielded and therefore should be as short as possible!
- The leads of one motor phase, see Fig. 5, should be twisted pairs, e.g. A and B, C and D (4-lead motor).
- **The wires must not be stressed.** Provide strain relief when twisting, shortening or stripping the motor leads!
The motor's strain relief needs additional security when modifying the wires.

6.3 Direction of Rotation

The drive shaft of size 19 to 32 Phytron stepper motors turns counter clockwise, if viewed from the front (DIN 42 401, part 1). The motors of size 42 and above turn clockwise. The motor direction can be reversed by exchanging the connections of one single motor phase (e.g. exchange lead A and B at the control unit connector).

Motor Sizes VSS 19 to 32 / Bipolar Control Mode / Full Step Operation							
Function Diagram Rotation: Clockwise (CW)	Motor Phase Current		Motor Phase Polarity				Direction of Rotation
	Step	Phase 1	Phase 2	Phase 1		Phase 2	
				A	B	D	C
	1	+1	+1	+	-	-	+
2	-1	+1	-	+	-	+	
3	-1	-1	-	+	+	-	
4	+1	-1	+	-	+	-	
5	+1	+1	+	-	-	+	
CW = Clockwise CCW = Counterclockwise							

Motor Sizes VSS 42 to 125 / Bipolar Control Mode / Full Step Operation							
Function Diagram Rotation: Clockwise (CW)	Motor Phase Current		Motor Phase Polarity				Direction of Rotation
	Step	Phase 1	Phase 2	Phase 1		Phase 2	
				A	B	D	C
	1	+1	-1	+	-	+	-
2	-1	-1	-	+	+	-	
3	-1	+1	-	+	-	+	
4	+1	+1	+	-	-	+	
5	+1	-1	+	-	+	-	
CW = Clockwise CCW = Counterclockwise							

How to Handle In-Vacuum and Cryo Stepper Motors

7 Temperature Measuring (Motors with Temperature Sensor)

In vacuum environments, there is the danger of overheating the stepper motor because of the lack of heat dissipation by ambient air. To avoid damages, use a motor with built-in temperature sensor.

Phytron VSS stepper motors are available with type K thermal elements or type Pt100 resistor sensors.

The insulated temperature sensor is integrated in the motor windings. The response time is very short, compared to temperature sensors mounted outside the motor housing. The temperature is measured all the time, even if only one motor phase is powered at any one time.

7.1 Type K Thermal Element

With VSS in-vacuum and Cryo stepper motors, Type K (NiCr-Ni) thermal elements in the temperature range from -270 to $+1370$ °C, accuracy class 1, are used.

Type K is a metal thermal element with nickel-based alloy conductors. Temperature ranges, accuracy and characteristics of thermal elements for industrial use are defined in the IEC 584 standard (temperature measuring with thermal elements).

The accuracy of the applied thermal elements class 1 is:

-40 to $+300$ °C $\pm 0.004 \times t$ or ± 1.5 °C

t = actual temperature, the higher value is valid.



CAUTION – Possible damage!

Type K Thermal Element:

- The thermal element's leads are the same colour and insulated with Kapton™ foil.
- **Check for correct polarity!** The minus pole is magnetic.
- Only connectors specified for K elements should be wired.

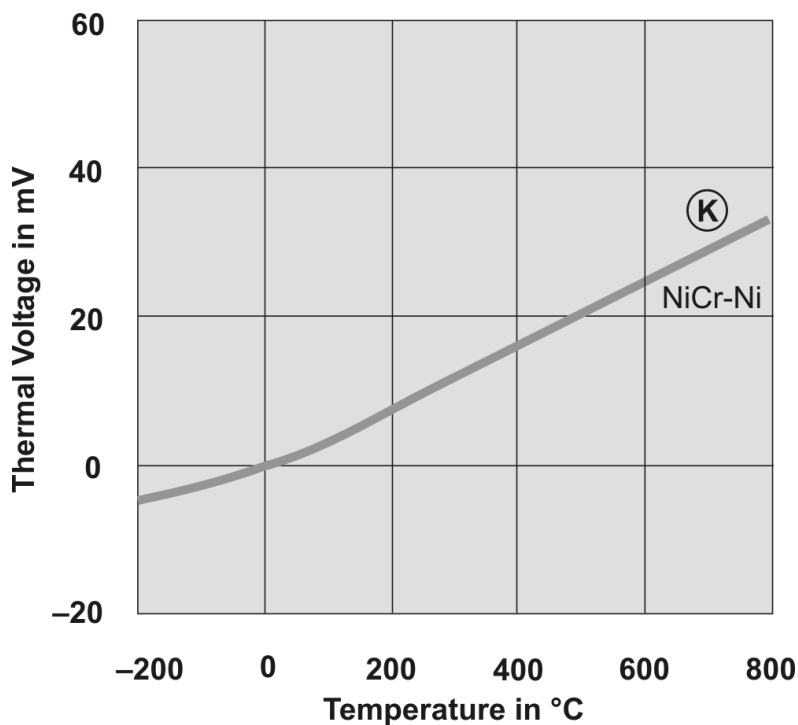

Fig. 7 : Type K thermal element characteristic curve

7.2 Pt100 Resistor Sensor

Pt100 resistor sensors are used with VSS in-vacuum and Cryo stepper motors in the temperature range -200 to $+300$ °C.

These precise sensors are used in extreme industrial and laboratory conditions. They consist of a wound resistance wire that is mounted and supported inside a cylindrical ceramic case.

Rated resistance at 0 °C: $R_0 = 100 \pm 0.1 \Omega$

Resistance at 100 °C: $R_{100} = 138.5 \pm 0.27 \Omega$

The resistance values for other temperatures can be found in the fundamental value tables for Pt100 resistance sensors.

Accuracy class: $T = 1/3$ of class B acc. to DIN EN 60751

In accuracy class T the valid scope is reduced to -70 to $+250$ °C.

For temperatures below -70 °C class B is valid.

Tolerance class	Scope	Tolerance in K	Tolerance	
			t = 0 °C	t = 100 °C
Class T (1/3 Class B)	$-70 \dots +250$ °C	$\pm (0.10 \text{ K} + 0.0017 \times t)$	$\pm 0.10 \text{ K}$	$\pm 0.27 \text{ K}$
Class B	$-200 \dots +600$ °C	$\pm (0.30 \text{ K} + 0.0050 \times t)$	$\pm 0.3 \text{ K}$	$\pm 0.80 \text{ K}$

How to Handle In-Vacuum and Cryo Stepper Motors

The platinum sensors are connected with four leads in order to enable independent measuring of the wire resistance. The leads are insulated with Kapton foil and marked with PTFE tubes (see picture below). Before placing the motor into operation in UHV vacuum, the PTFE tubes should be removed, see section 6.2.

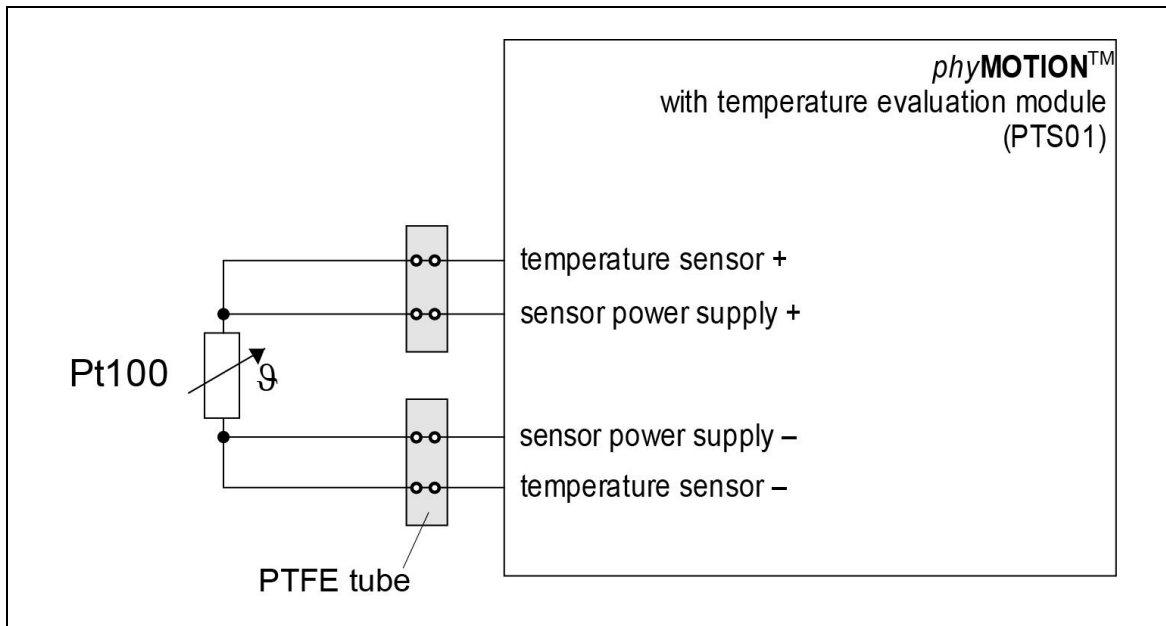

Fig. 8 : Pt100 connection to a control unit with temperature monitoring module

8 Conditioning In-Vacuum Stepper Motors

8.1 Overview

To remove volatile organic substances from the motor materials, an outgassing procedure is executed with UHV stepper motors. Outgassing is adapted to the specified requirements of the stepper motor. During the **Baking Out**, the motor is baked out in an oven in dry nitrogen. During **First Outgassing** and **Degas** (shortened heating), the motor is heated by powering the motor windings in vacuum.

The outgassing temperature at **First Outgassing** and **Degas** is set by the motor current. It should be equal to the maximum rated stepper motor temperature.

Rule of thumb: Each 100 Kelvin outgassing temperature increase gains one decimal power of outgassing rate.

8.2 Baking Out (Option)

Alternatively to first outgassing, HV stepper motors can be baked out in dry nitrogen before placing into operation. The stepper motor is externally heated up to the maximum rated temperature.

This Baking Out is recommended as an option for Phytron HV stepper motors.

8.3 First Outgassing (Standard)

A First Outgassing is performed in vacuum environment at 10^{-6} mbar pressure with all UHV stepper motors (not UHVC) by Phytron. The phase current is varied to hold the winding temperature at 200 °C for 24 hours.

For the other vacuum motor types, First Outgassing is an order option.

8.4 Degas (Option)

Degas is a short heating of the motor windings (about 5 minutes) to maximum temperature before each placing into operation. After a corresponding cool-down time the stepper motor can be operated up to 50 K below the Degas temperature without emitting volatile substances.

Degas can be ordered as option.

9 Storage

Depending on the ball bearing lubricant, HV stepper motors can be stored for up to 2 years in the original foil package, UHV stepper motor at least 5 years, without influence to function or specified characteristics.

The storing temperature should be between +5 and +50 °C.

After removing the foil package, the stepper motor must only be kept in a clean box, clean room or closed container.

10 Technical Data

10.1 Vacuum Classes

	vacuum class [hPa]	winding temperature [°C]	radiation re- sistant up to [Mrad]	conditioning of the components	First outgassing at Phytron	TML [%]	CVCM [%]
High vacuum HV	10 ⁻⁷	-20 ... +200	10 ²	-	option	-	-
Ultra high vacuum UHV-S (solid lubrication)	10 ⁻¹¹	-20 ... +200	10 ⁶	yes	yes	< 1	< 0.1
UHV-G (grease lubrication)	10 ⁻¹¹	-20 ... +300	10 ⁶	yes	yes	< 1	< 0.1
Ultra high vacuum Cryo UHV-C1	10 ⁻¹¹	-200 ... +40	10 ⁶	yes	-	< 1	< 0.1
UHV-C2	10 ⁻¹¹	-270 ... +40	10 ⁶	yes	-	< 1	< 0.1

10.2 Design Voltage

Motor Size	Design Voltage	Remarks
19 ... 57	70 V _{DC}	Operation with SELV type supplies
80 ... 126	120 V _{DC}	Operation with safe/double separation to mains

10.3 Test Voltage

Motor Size	Housing – Motor Winding	Housing – Temperature Sensor	Motor Winding – Temperature Sensor
19 ... 42	480 V _{AC} 1 min	480 V _{AC} 1 min	480 V _{AC} 1 min
52 ... 126	1200 V _{AC} 1 min	1200 V _{AC} 1 min	1200 V _{AC} 1 min

11 Declaration of Incorporation



Declaration of Incorporation according to EC directive 2006/42/EC on machinery (Annex II B) for partly completed machinery

Name and address of the manufacturer:

Phytron GmbH,
Industriestr. 12
82194 Gröbenzell

Representative in EU, authorized to compile the relevant technical documentation:

Rainer Gareis
Phytron GmbH,
Industriestr. 12
82194 Gröbenzell

Description of the partly completed machinery:

Product denomination: Schrittmotoren mit Bemessungsspannung < 50Vac
Model/Type: LSS 26, RSS 56, RSS 57, RSS 79, VSS 19, VSS 20, VSS 25, VSS 26, VSS 32, VSS 33, VSS 41, VSS 42, VSS 43, VSS 52, VSS 55, VSS 56, VSS 57, ZSS 19, ZSS 20, ZSS 25, ZSS 26, ZSS 31, ZSS 32, ZSS 33, ZSS 41, ZSS 42, ZSS 43

From serial number 1604xxxxx

We declare that the product complies with the following essential requirements of the Machinery Directive 2006/42/EC:

1.1.2.; 1.1.5.; 1.3.1.; 1.3.2.; 1.3.3.; 1.3.4.; 1.3.7.; 1.5.1.; 1.5.2.; 1.5.4.; 1.5.5.; 1.5.6.; 1.5.16.; 1.7.2.; 1.7.3.; 1.7.4.

We declare that the relevant technical documentation is compiled in accordance with part B of Annex VII.

We commit to transmit, in response to a reasoned request by the market surveillance authorities, relevant documents on the partly completed machinery.

Important note! The partly completed machinery must not be put into service until the final machinery into which it is to be incorporated has been declared in conformity with the provisions of Directive 2006/42/EC on Machinery, where appropriate, and until the EC Declaration of Conformity according to Annex II A is issued.

Gröbenzell, 2016-04-20

Henning Brunke
Technical Director

