

Ezi-MOTIONLINK[®]

Network based Motion Controller Plug-in to Servo Drives

- Ethernet Type Motion Controller
- Compatible with Various Servo Drives
- Various Motion Functions
- Reduced Wiring

Plus-E



CE

FASTECH

Fast, Accurate, Smooth Motion



Fast, Accurate, Smooth Motion

Ezi-MOTIONLINK[®] Plus-E

Network based Motion Controller Plug-in to Servo Drives



1 Network Based Motion Controller

A maximum of 254 axis can be operated from a PC through Ethernet communications. And daisy-chain connection is available thru internally equipped Ethernet HUB. All of the Motion conditions are set through the network and saved in Flash ROM as a parameter. Motion Library(API) is provided for programming under Windows 7/8/10.

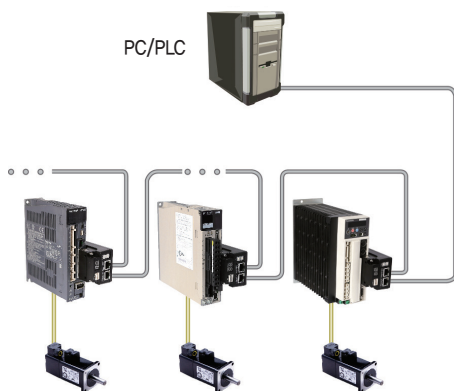

2 Flexible System Construction

Ezi-MOTIONLINK Plus-E can be directly connected to the servo drive through the attached connector, so you can easily install the product without additional wiring. In addition, since it is compatible with servo drives of various companies, the system can be built flexibly.



3 Various Motion Function

Ezi-MOTIONLINK Plus-E has various functions required for motion control system, and you can set up motions simply and conveniently by using the provided GUI (Graphical User Interface) software.

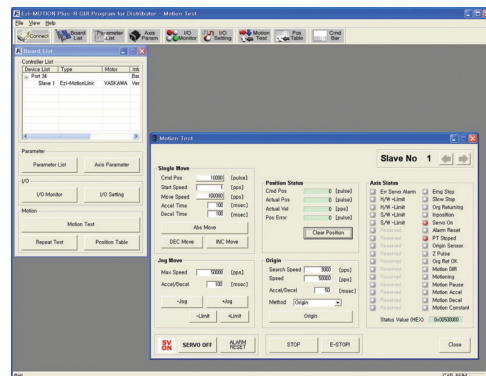

● Ezi-MOTIONLINK Plus-E Part Numbering

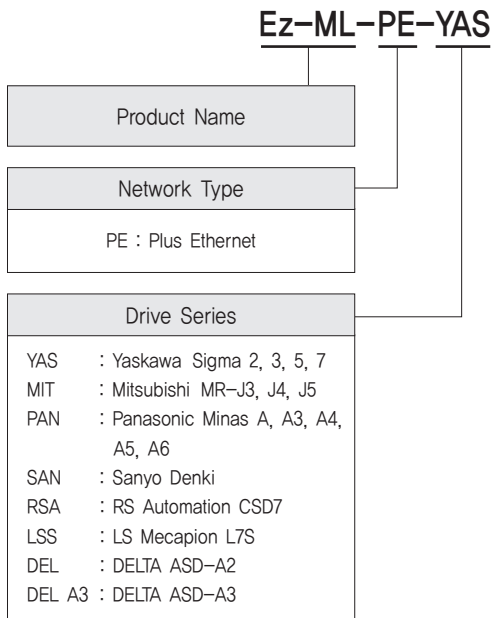

● Part Number

Part Number
Ez-ML-PE-YAS
Ez-ML-PE-MIT
Ez-ML-PE-PAN
Ez-ML-PE-SAN
Ez-ML-PE-RSA
Ez-ML-PE-LSS
Ez-ML-PE-DEL
Ez-ML-PE-DEL A3

● Dimensions of Controller [mm]

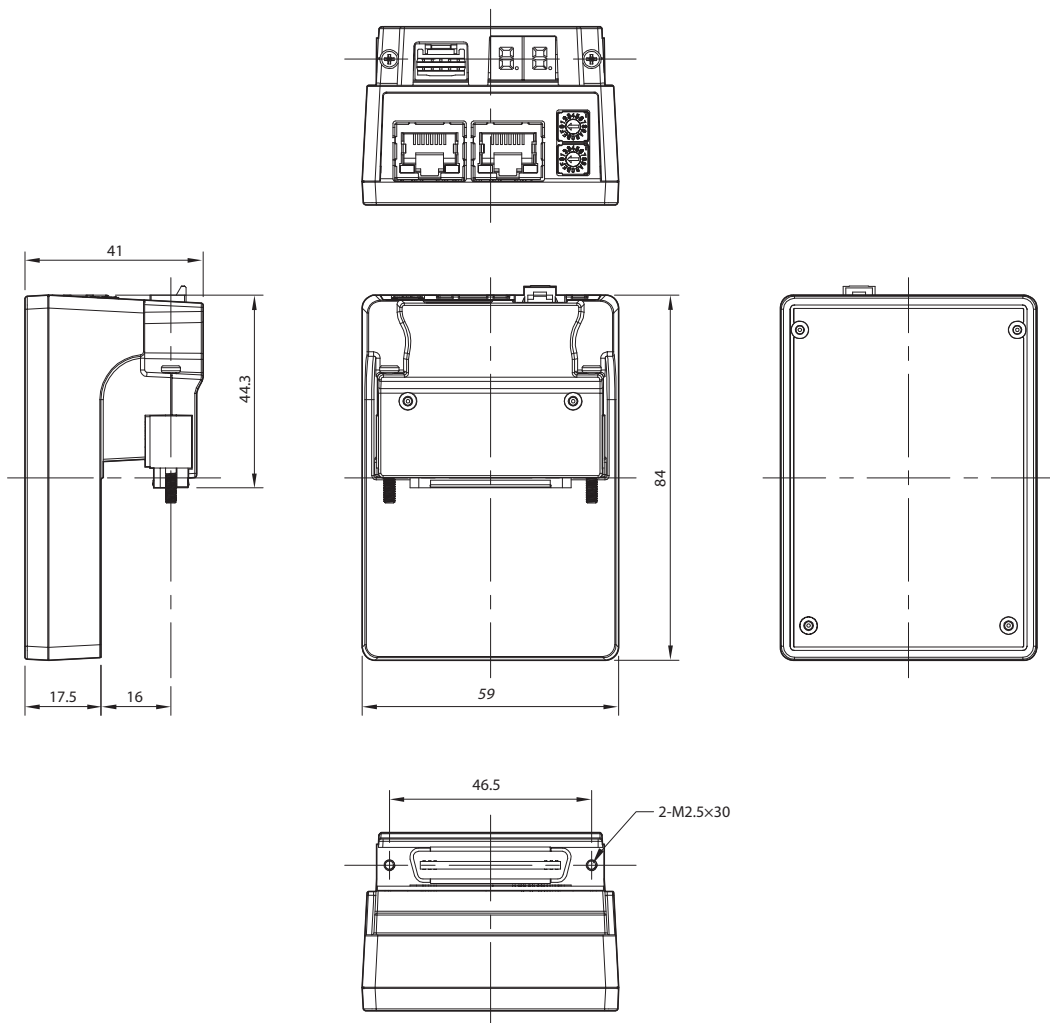

● Specifications of Controller

Input Voltage		DC24V±10%
Multi Axis Drive		Maximum 254 axis operating (Selectable IP: 1~254)
Current Consumption		Max. 500mA
Operating Condition	Ambient Temperature	· In Use: 0~55°C · In Storage: -20~70°C
	Humidity	· In Use: 35~85% RH (Non-Condensing) · In Storage: 10~90% RH (Non-Condensing)
	Vib. Resist.	0.5g
Function	LED Display	IP address, Alarm status
	Rotational Direction	CW/CCW (Set by parameter)
	Data Range	-134,217,728 ~ +134,217,727 [pulse] (28bit)
	ACC/DEC Process	Symmetric / Asymmetric trapezoidal acceleration & deceleration
	Command Pulse Output Method	2 pulse mode (CW/CCW) or 1 pulse mode (Pulse/Dir) (Set by parameter)
	Max. Output Frequency	5MHz
	Encoder Max. Input Frequency	4MHz
I/O Signal	Input Signals	3 dedicated inputs (LIMIT+, LIMIT-, ORIGIN), 1 programmable input (Photocoupler Input)
	Output Signals	1 programmable output (Photocoupler Output), 1 Brake output
Communication Interface		· Ethernet standard: 10BASE-T, 100BASE-TX · Full-Duplex · Dual port Ethernet switch embedded
Position Control		· Incremental mode / Absolute mode Data Range: -134,217,728 to +134,217,727 [pulse] · Operating speed: Max. 3,000 r/min
Return to Origin		Origin Sensor, Z phase, ±Limit sensor
GUI		User Interface Program within Windows
Library		Motion Library (API) for windows 7/8/10

Settings and Operation

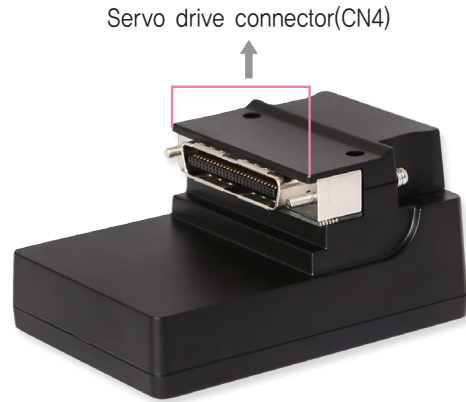
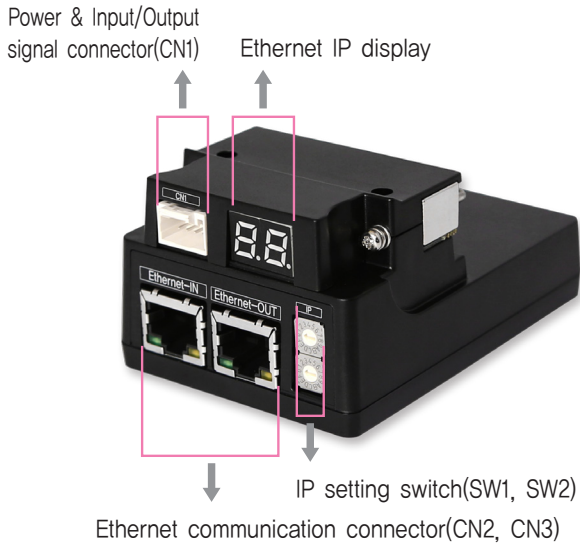

1. Ethernet IP Display and Setting Switch(SW1, SW2)

These switches set the 4th octet of Ethernet IP, and the value is shown in 7-segment LED display(Default setting is "192.168.0.xxx-" and xxx is set by switches). If the switches are set to 255(FF), DHCP function is activated, and IP is automatically set, ignoring the set value. (Please refer to the manual for details.)

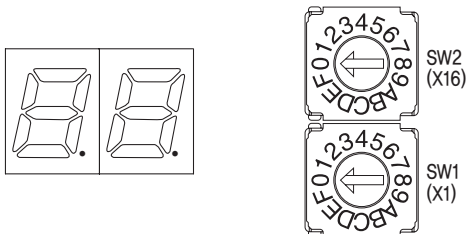

e.g.,) In case of SW2 : 5 and SW1 : 7
 $(5 \times 16) + (7 \times 1) = 87$
 IP is to be set as 192.168.0.87

2. Ethernet Communication Connector(CN2, CN3)

No.	Function	No.	Function
1	TD+	6	RD-
2	TD-	7	----
3	RD+	8	----
4	----	Connector hood	F_GND
5	----		

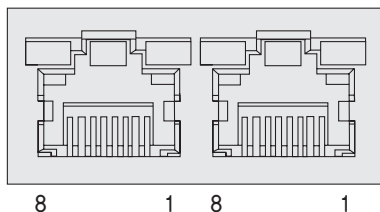

3. Servo Drive Connector(CN4)

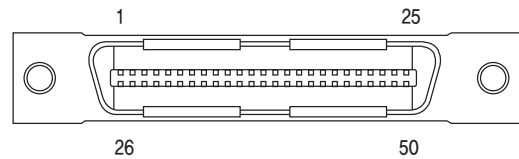

The pin map of servo drive connector differs depending on the servo drive type. (Please refer to the manual for details.)

4. Power & Input/Output Signal Connector(CN1)

No.	Function	I/O
1	DC24V	Input
2	GND	Input
3	EXT_DC24V	Output
4	EXT_GND	Output
5	LIMIT+	Input
6	LIMIT-	Input
7	ORIGIN	Input
8	Digital In1	Input
9	BRAKE	Output
10	Digital Out1	Output

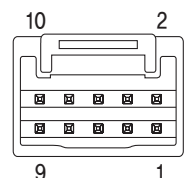

● System Configuration

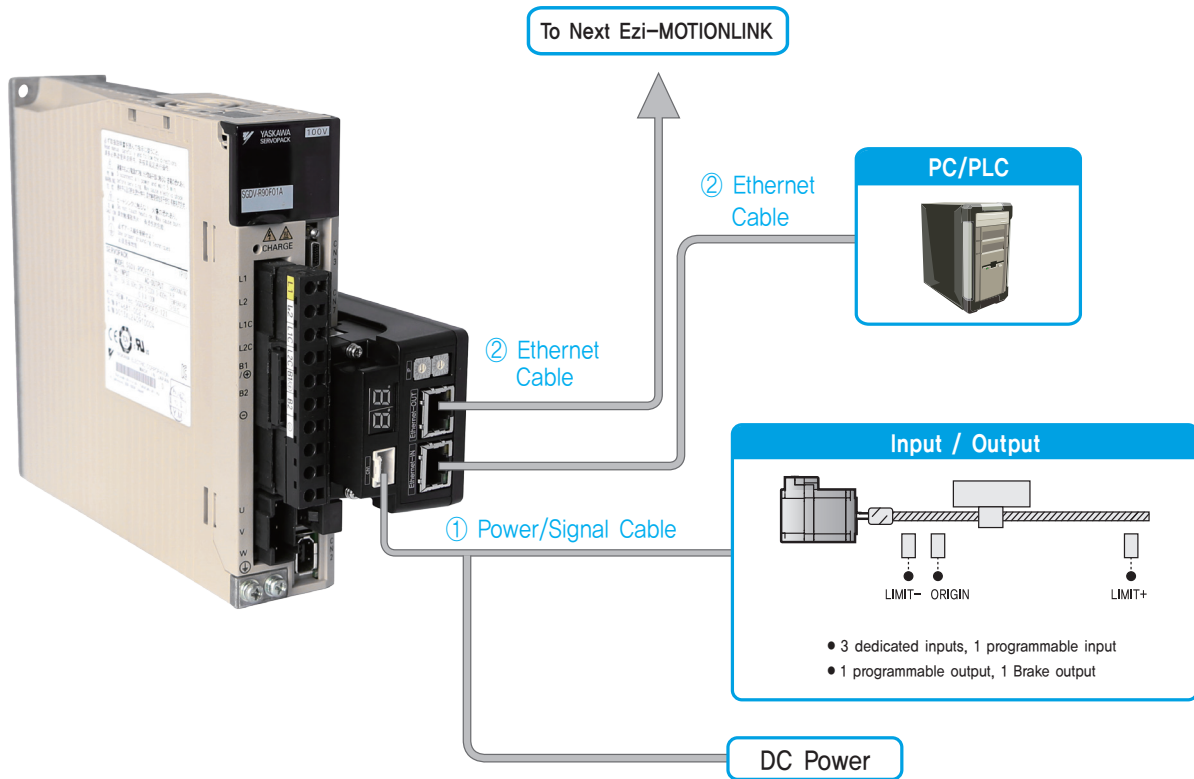

1. Accessories

Connectors

These are connector specifications for controller cabling.

Purpose	Item	Part Number	Manufacturer
Power/Signal (CN1)	Housing	501646-1000	MOLEX
	Terminal	501648-1000 (AWG 26~28)	

※ The connectors above are supplied with the product. If you are using other parts, please make sure they meet the specifications.

2. Options

① Power/Signal Cable

These are the cables to connect Ezi-MOTIONLINK Plus-E, power, and other input/output devices.

Purpose	Part Number	Length [m]	Cable Type	Remarks
Controller – Power & I/O Device Connection	CSPE-S-001F	1	Normal Cable	Maximum Length: 20m
	CSPE-S-002F	2		
	CSPE-S-003F	3		
	CSPE-S-005F	5	Robot Cable	
	CSPE-S-001M	1		
	CSPE-S-002M	2		
	CSPE-S-003M	3		
	CSPE-S-005M	5		

* If you need cables with length(in units of 1m) not listed on the table, please contact FASTECH for more information.

② Ethernet Cable

Purpose	Part Number	Length [m]	Remarks
Ethernet Connection	CGNR-EC-001F	1	<ul style="list-style-type: none"> · STP(Shielded Twisted Pair) Cable · Category 5e or higher · Maximum Length: 100m · Normal Cable
	CGNR-EC-002F	2	
	CGNR-EC-003F	3	
	CGNR-EC-005F	5	

* If you need cables with length(in units of 1m) not listed on the table or robot cables, please contact FASTECH for more information.

External Wiring Diagram

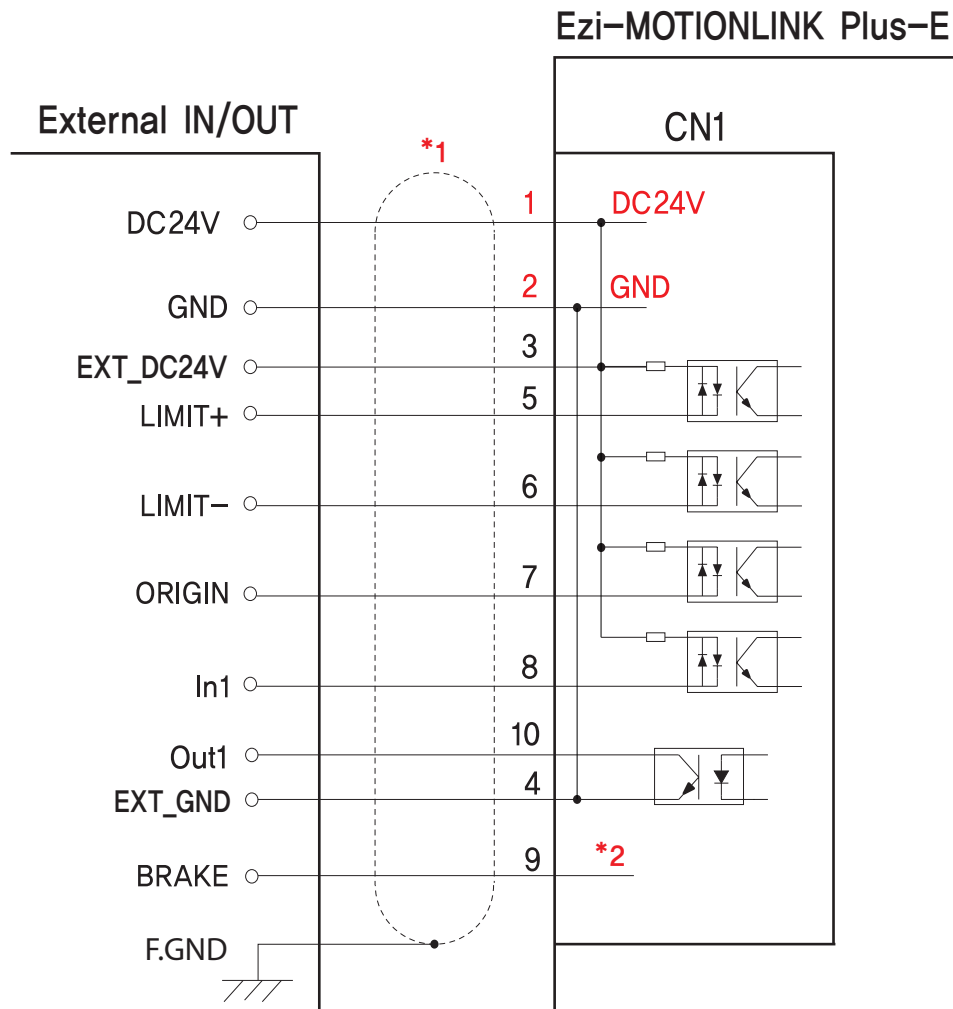

* 1) Shield Cable

* 2) The brake terminal is an extension of the brake signal line of the servo drive. Therefore, when connecting the brake, refer to the user's manual of the servo drive.

※ When connecting I/O cable between controller and drive, please turn of the power of both controller and drive to prevent electric shock or to protect the drive from any damage.

CAUTION

In order to use the products listed in this catalog safely and correctly, be sure to read the instruction manual before using the product.

GUI(Graphic User Interface) Program

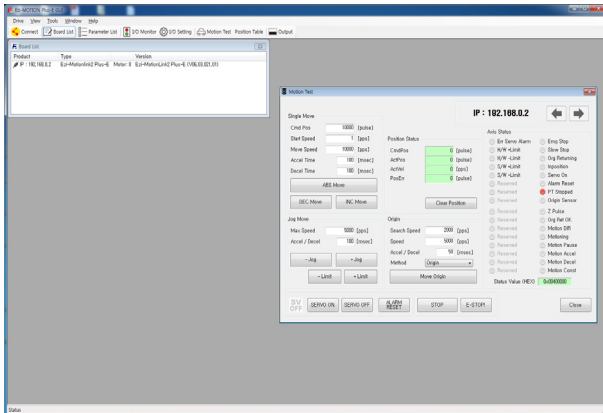

◆ Product List and Motion Test

The product list shows the products connected to the host controller. You can test single position movements, jog movements, and origin search operations, and monitor the operation status on the motion test window.

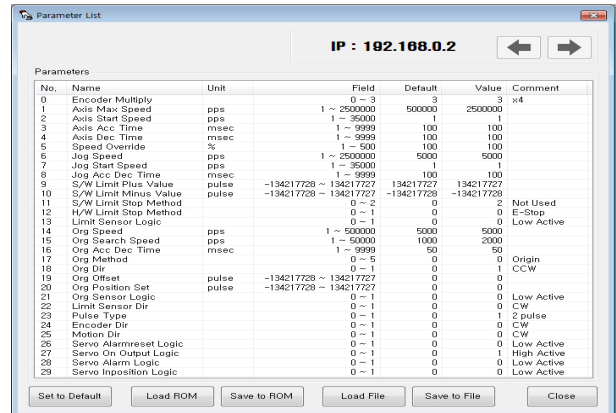

◆ Parameter List

All of the parameters are displayed and modified on this screen.

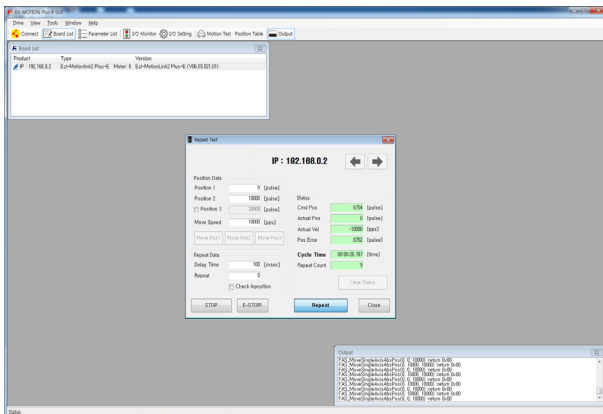

◆ Motion Repeat and Status Monitoring

You can set the target position value, speed, delay time and number of repetitions for repeated motion test. A motion library(API) is also displayed on the screen.

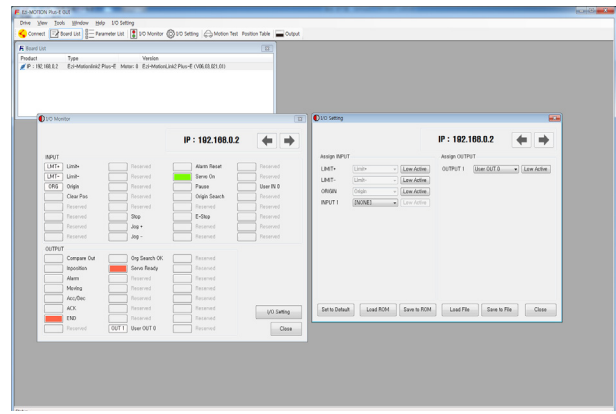

◆ I/O Monitoring and Setting

You can check the status of input/output signals related to the current operation status, and you can assign the signals to the desired input/output channels.

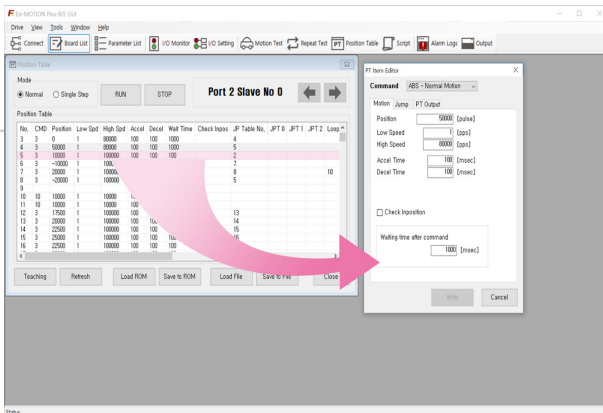

◆ Position Table

You can configure the data for the position table function or drive the motor with the position table. The position table is a function that allows you to easily operate the motor with motion data stored in memory in advance.

- ※ GUI Program(Ezi-MOTIONLINK Plus-E) can be downloaded from website, (www.fastech-motions.com)
- ※ GUI Program(Ezi-MOTIONLINK Plus-E) supports Windows 7/8/10.
- ※ GUI Program(Ezi-MOTIONLINK Plus-E) is subject to change without prior notice for performance improvement.

MEMO



Fast, Accurate, Smooth Motion

FASTECH Co., Ltd.

Rm#1202, 401-dong, Bucheon Techno-Park,
655, Pyeongcheon-ro, Bucheon-si Gyeonggi-do,
Republic of Korea (Postal Code: 14502)
TEL : +82-32-234-6317 FAX : +82-32-234-6302
E-mail : sales@fastech-motions.com
Homepage : www.fastech-motions.com