

11.4 Type HC – Servo hypoid gearboxes

11.4.1 General construction

The HC gearbox type is based on the proven type H bevel gearboxes. The axles intersect in the gearbox at the distance A in an angle of 90°.

Gearbox size	090	115	140	170	215	260
A [mm]	9	14	18	23	32	42

The edge length of the housing is reflected in the gearbox size (example: HC 090: the housing edge length is 90 mm, with the viewing direction towards the output side of the gearbox). The housings are made of aluminium, the shaft suspension units are made of steel or casting.

11.4.2 Tothing

ATEK hypoid gearboxes have gear sets with high-quality hypoid tothing made of hardened carburised steel. A gear set comprises one pinion shaft (small number of teeth / small diameter) and one bevel gear (large number of teeth / large diameter).

Gear sets with spiral tothing offer the advantage of very favourable engagement factors (high meshing ratio). Therefore they are predestined for usage with high loads.

On hypoid gear sets, the axial offset between pinion shaft and gear results in higher sliding motion rates in the tooth contact. This makes it possible to achieve especially great running smoothness and a high transmission accuracy.

11.4.3 Models

Due to the modular system, different gearbox Models can be configured.

Model	consists of:
BO through EO	1 gear set

Table 11.4.3-1

The variants differ in the type of the shafts, the rotational direction thereof, and the possibility to use a robot flange interface (BR0 and CR0).

11.4.4 Threaded mounting holes

The sides 1 and 2 of the gearboxes are machined and may be used as mounting surfaces. The flange on side 3 has also threaded mounting holes. On the sides 5 and 6, fastening can be made via through bores.

You have the following available ordering options:

Gearbox size	Ordering options	Threaded mounting holes are in the housing surfaces on the gearbox side	Threaded mounting holes are in the flanges on the gearbox side
040-250	1	1	5.6
040-100	2	1.2	5.6
040-100	4	1.4	5.6
040-100	5	1.5	5.6
040-100	6	1.6	5.6

Table 11.4.4-1

Please enquire other mounting options.
The standard version of the mounting / fastening has the order code 9.
Example of order code: HC 090 12:1 D0 9.1

11.4.5 Installation position

The gearboxes can be used in all installation positions. The recommended installation position is the position in which the shafts are horizontal.

These are the installation positions 1 and 2. The installation position is defined by the gearbox side directed downwards during operation and will be indicated by the corresponding gearbox side. Example of order code for the installation position 1: HC 090 12:1 D0 9.1

11.4.6 Shaft designation – allocation to the gearbox sides

The fast-rotating shaft has the speed n_1 and is identified by N_1 . The hypoid pinion is located on this shaft. The slowly rotating shaft has the speed n_2 and is identified by N_2 . The hypoid gear is located on this shaft. The gearbox sides are identified by the numerals 1 to 6.

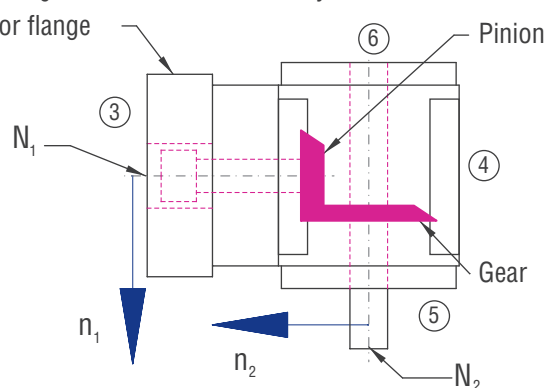

Figure 11.4.6-1; Shaft designations

11.4.7 Preferred direction of rotation

If the clockwise (CW) direction of rotation (viewing direction from shaft end face of the fast-rotating shaft towards the gearbox centre) is selected, a lower noise level is generated.

11.4.8 Efficiency

The achievable efficiency depends on rotational speed, torque, installation position, sealing, and lubricant type. The efficiency is about 95%. The efficiency specified relates to the permissible nominal load and is a guidance value for run-in gearboxes at operating temperature with standard sealing.

11.4.9 Lubrication

The H-series gearboxes have lifetime lubrication.

11.4.10 Vent filter

If venting is required (B1 or C1) the gearboxes will be delivered with a vent filter. The vent bores will be equipped with screw plugs for transport. The vent filter will be enclosed as a separate item and must be mounted in the intended position prior to commissioning. An elbow may be required. Please adhere to the operating instructions!

11.4.11 Low-backlash construction

For low-friction running, the tooth space in the gear set is manufactured larger than the tooth. When the direction of rotation is changed, this results in a rotation angle until the counter-rotating tooth flanks contact each other. This rotation angle is called circumferential backlash.

Circumferential backlash, measuring method

The circumferential backlash is measured after the drive shaft N_1 has been fixed. A force of around 2% of the nominal torque is applied to the output shaft N_2 in both rotational directions. A tooth backlash will result between the two final positions. This can be measured as rotation angle and is indicated in minutes of arc [arcmin].

Circumferential backlash, type

Ordering option	Gear set	090 – 115	140 – 260
/0000	Standard	<=5 arcmin	<=4 arcmin
/S2	Standard	-	-
/S1	Standard	-	-
/S0	Standard	<=3 arcmin	<=2 arcmin

Table 11.4.11-1

11.4.12 Connection of drive shaft to coupling

For torque transmission, a zero-play coupling is located on the drive shaft

11.4.13 Coupling

The coupling compensates angle errors as well as misalignments in the radial and axial direction.

A later changeover to another motor is possible. The motor-side coupling hub is available in the following variants:

BK	BKN
Bellows coupling	Bellows coupling
For motor shafts without parallel key	For motor shafts with parallel key

11.4 Type HC – Servo hypoid gearboxes

Design of the coupling

Torque T_1 [Nm] that can be transmitted by the coupling at a motor shaft diameter d [mm]

d [mm]	Gearbox size					
	090	115	140	170	215	260
5	7					
6	10					
7	9					
8	10.5	18				
9	12	20				
10	12	22				
11	12	33.1				
12	12	33.8				
13	12					
14	12	35	65			
15	12	35	65			
16	12	35	65			
17	12					
18	12	35	65			
19	12	35	65	150		
20	12	35	65			
21	12					
22	12					
24	12	35	65			
25		35	65		360	360
28		35	65			
30		35	65		360	360
32			65			
35			65		360	360
38			65			
40					360	800
42				150		
45					360	360
50					360	360
55					360	360
60					360	360
75						800

11.4.14 Motor mounting

The servo-motor will be bolted to the motor flange of the gearbox.

The flange number of the motor flange for the respective gearbox size is to be determined in Table 11.4.14-1.

Motor flange

The motor flange adapts the mounting bores of the servo-motor and gearbox flange. You can find the available flanges in Table 11.4.14-1.

Please contact us for other flanges.

- ZK: Diameter of centring circle
- LK: Diameter of pitch circles
- L: Length of motor shaft
- d: Diameter of motor shaft
- i: Centring height
- s: Thread

The values for the centring height (i) and the thread sizes (s) can be found on the respective pages.

The flange tolerances are dimensioned for servo-motors of tolerance class N.

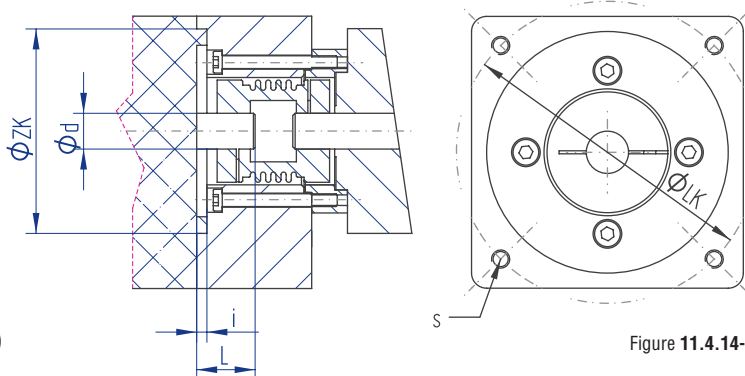

Figure 11.4.14-1

Allocation: Fitting dimensions of the servo-motor – gearbox size/flange no. (selection)

d min [mm]	d max [mm]	L min [mm]	L max [mm]	LK [mm]	ZK [mm]	Gearbox size	Flange no.
3	24	21	38	63	40	090	001
3	24	21	38	63	40	090	002
3	24	21	38	75	60	090	104
5	24	22	50	75	60	090	104
3	24	21	38	90	60	090	201
3	24	21	38	95	50	090	301
5	24	22	50	95	50	090	301
5	24	22	50	100	80	090	401
5	24	22	50	115	95	090	501
5	24	22	50	130	95	090	601
5	24	22	50	130	110	090	611
5	24	22	50	145	110	090	701
5	24	22	50	165	110	090	802
3	24	17.5	34.5	70	40	090	950
3	24	21	38	70	50	090	952
5	24	22	50	90	70	090	954
5	24	37	65	115	95	090	955
5	24	40	68	145	110	090	956
5	24	22	50	90	70	090	959
3	24	21	38	70	50	090	963
3	24	21	38	46	30	090	964
3	24	21	38	100	50	090	967
5	24	37	65	130	95	090	975
5	24	29	57	100	80	090	977
5	24	37	65	130	110	090	980
5	24	37	65	100	80	090	987
8	26	24	53	63	40	115	001
8	26	24	53	75	60	115	104
8	26	24	53	95	50	115	301
10	30	35.5	60	95	50	115	301
8	26	24	53	100	80	115	401
10	30	35.5	60	100	80	115	401
8	26	24	53	115	95	115	502
10	30	35.5	60	115	95	115	502
8	26	24	53	130	95	115	601
10	30	35.5	60	130	95	115	601
8	26	24	53	130	110	115	611
10	30	35.5	60	130	110	115	611
8	28	24	53	145	110	115	701
10	30	35.5	60	145	110	115	701
8	26	24	53	90	70	115	954
8	26	24	53	90	70	115	959
10	30	40.5	65	145	110	115	959
10	30	35.5	60	90	70	115	960
8	26	24	53	70	50	115	964
10	30	40.5	65	130	110	115	967
10	30	40.5	65	130	95	115	971
10	30	42.5	67	100	80	115	972
8	26	24	53	70	50	115	986

Table 11.4.14-1

Servo gearboxes
(precision gearboxes)

11.4 Type HC – Servo hypoid gearboxes

d min [mm]	d max [mm]	L min [mm]	L max [mm]	LK [mm]	ZK [mm]	Gearbox size	Flange no.
14	38	31.5	60	95	50	140	301
14	38	31.5	60	100	80	140	401
14	38	32	60	115	95	140	502
14	38	31.5	60	115	95	140	502
14	38	32	60	130	95	140	601
14	38	31.5	60	130	95	140	601
14	38	32	60	130	110	140	611
14	38	31.5	60	130	110	140	611
14	38	31.5	60	145	110	140	701
14	38	32	60	165	110	140	802
14	38	31.5	60	165	110	140	802
14	38	32	60	165	130	140	811
14	38	32	60	215	130	140	902
14	38	32	60	215	180	140	911
14	38	52	80	215	180	140	932
14	38	47.5	76	145	110	140	950
14	38	37	66	145	110	140	951
14	38	31.5	60	90	70	140	960
14	38	38.5	67	100	80	140	972
19	42	39	65	115	95	170	502
19	42	39	65	130	95	170	601
19	42	39	65	130	110	170	611
19	42	39	65	165	110	170	802
19	42	39	65	165	130	170	811
19	42	46	80	165	130	170	811
19	42	39	65	215	130	170	902
19	42	46	80	215	130	170	902
19	42	39	65	215	180	170	911
19	42	46	80	215	180	170	912
19	42	84	110	215	180	170	931
19	42	77.5	103	215	180	170	932
19	42	44	70	145	110	170	951
19	42	46	80	200	114.3	170	952
19	42	84	110	200	114.3	170	952
24	60	44.5	82	165	130	215	811
24	60	44.5	82	215	130	215	902
24	60	44.5	82	215	180	215	913
24	60	56.5	94	200	114.3	215	952
24	60	72.5	110	300	250	215	960
24	60	56.5	94	265	230	215	961
24	60	79.5	117	215	180	215	963
24	60	44.5	75	165	130	260	811
24	60	44.5	75	215	130	260	902
24	60	44.5	75	215	180	260	913
40	75	61.5	110	350	300	260	916
24	60	50	87	200	114.3	260	952
24	60	50	87	265	230	260	961
24	60	72.5	103	300	250	260	962
24	60	79.5	110	215	180	260	963

Table 11.4.14-1

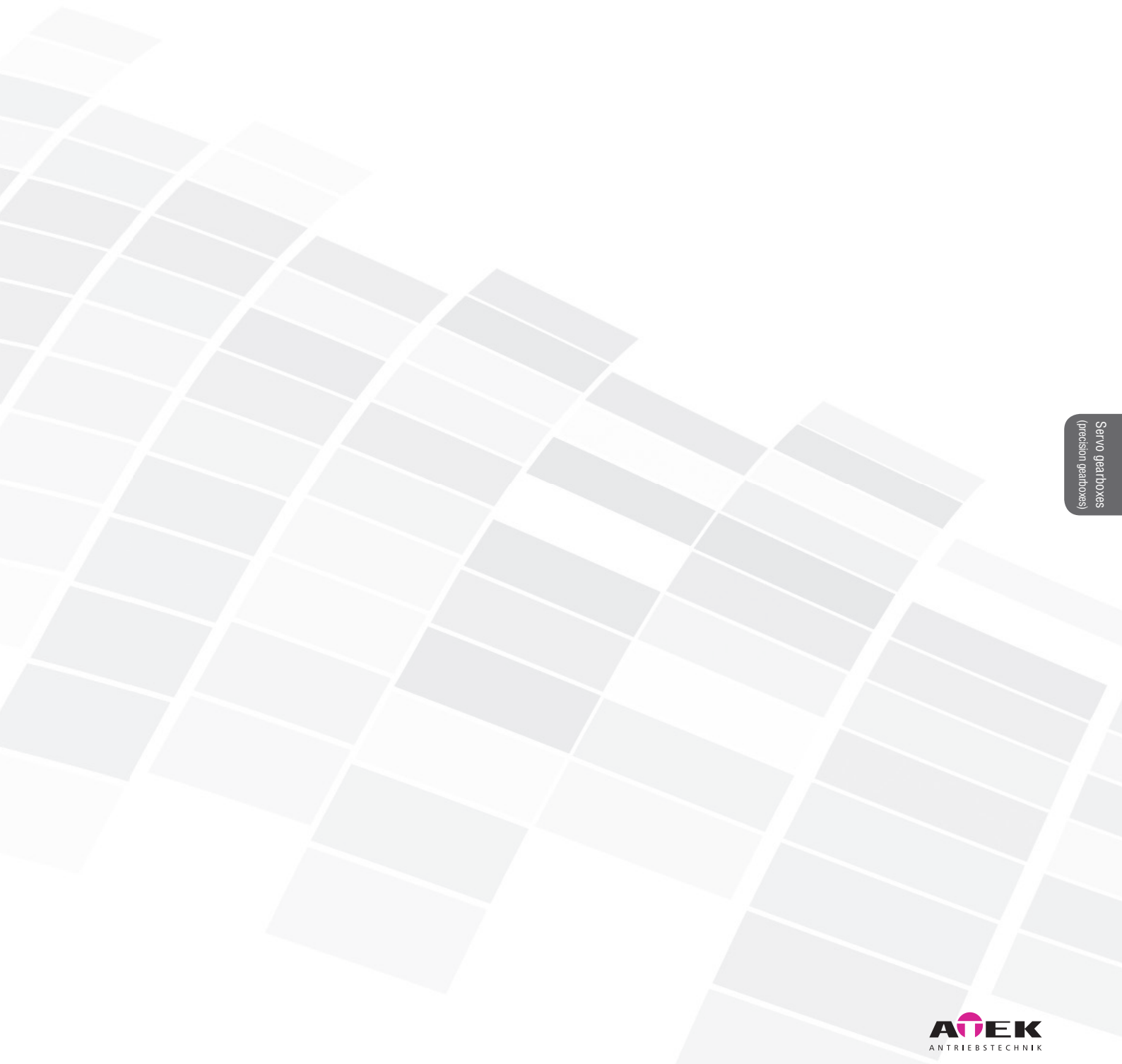

Servo gearboxes
(precision gearboxes)

11.4 Type HC – Servo hypoid gearboxes

11.4.15 Features

Gear ratios: $i = 3:1$ to $15:1$ (others upon request)
 Maximum acceleration torque on output: 2160 Nm
 6 gearbox sizes with edge lengths of 090 to 260 mm
 Minimised circumferential backlash (optional)
 Housing made of aluminium
 Hypoid gearboxes suitable for fitting servo-motors

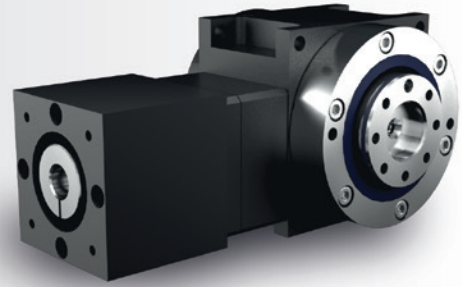

11.4.15.1 Models

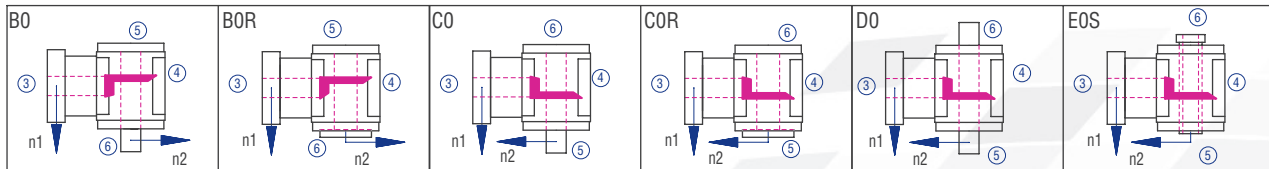

Figure 11.4.15-1; Models

11.4.15.2 Gearbox sides

The example shows the Model C0

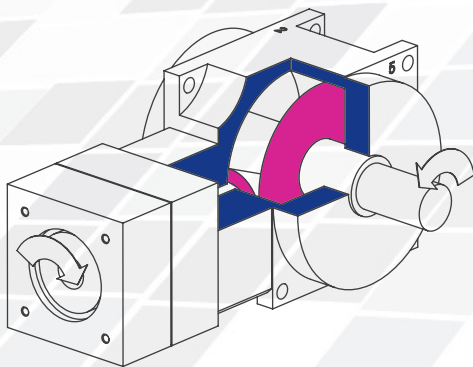

Figure 11.4.15-3; Gearbox sides

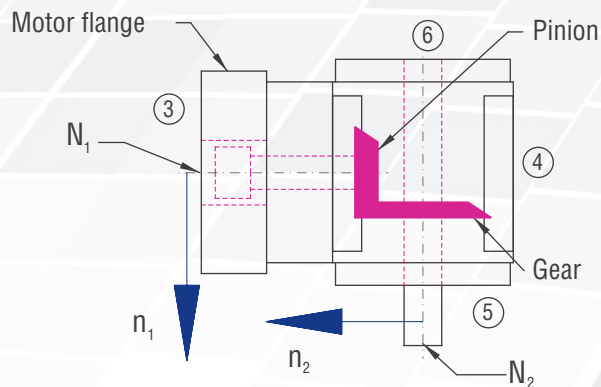

Figure 11.4.15-2; Shaft designations

11.4.15.3 Order code

The order code reflects the customer specifications. Example:

Type	Size	Gear ratio	Model	Fixing side	Installation position	Speed n_2	Design
HC	090	12:1	C0-	1.	1-	200	/S1
Description	Size; Table 11.4.15-1	Table 11.4.15-1	Figure 11.4.15-1, Models	Side on which fixing is made; Table 11.4.4-1; Figure 4.3.1-1 Gearbox sides	Side directed downwards; Figure 4.3.1-1 Gearbox sides	Slowly rotating shaft	Low-backlash S1
		V080-	/	14 x 30	No. 301		
		Flange		Motor shaft \varnothing x length	Flange no.		

11.4.15.4 Overview of performance data

Selection table: gearbox size; gear ratio; rotational speed

Size	n_{1MAX} [rpm]	n_1 [rpm]	8:1			10:1			12:1			15:1		
			T_{2N} [Nm]	T_{2B} [Nm]	T_{2NOT} [Nm]	T_{2N} [Nm]	T_{2B} [Nm]	T_{2NOT} [Nm]	T_{2N} [Nm]	T_{2B} [Nm]	T_{2NOT} [Nm]	T_{2N} [Nm]	T_{2B} [Nm]	T_{2NOT} [Nm]
090	8000	3200	36	54	72	36	54	72						
		3900							26	40	52	25	38	50
115	8000	2700	71	107	143	71	107	143						
		3300							52	79	108	50	75	100
140	7000	2200	142	215	289	143	215	290						
		2800							98	146	195	97	145	194
170	6000	1800	267	398	529	267	398	530						
		2300							188	280	370	182	278	369
215	5000	1200	723	1084	1450	723	1084	1450						
		1600							512	767	1022	512	767	1022
260	4500	1000	1444	2165	2887	1444	2165	2887						
		1300							1023	1533	2044	1023	1533	2044

Table 11.4.15-1

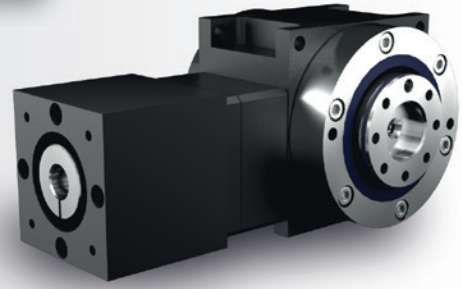

Characteristics

Characteristic	Standard	Option
Toothing	Spiral-toothed, hardened bevel gears	See chapter 11.4.2
Gear ratio	8:1 to 15:1	
Housing / Flanges	Aluminium / steel	
Threaded mounting holes	On the sides 1 and 2 and on the drive flange	See chapter 11.4.4
Shaft	Material 1 C45, shaft ends greased Fit with ISO 6 tolerance	See chapter 4.6.2
Hollow shaft	Material 1 C45, shafts greased Fit with ISO 6 tolerance	See chapter 4.6.3
Radial shaft seal ring	NBR, form A	See chapter 4.8
Ambient temperature	-10°C to +90°C. The values of the performance tables are valid for +20°C	See chapter 4.9.3
Circumferential backlash	< 5 arcmin	See chapter 11.4.11
Protection class	IP 54	See chapter 4.5
Corrosion protection	Prime coat; layer thickness > 40 µm	See chapter 4.4.1
Bearing life L10h	more than 30,000h in S5 operation	See chapter 4.9.1
Oil change intervals	Not required if the oil temperature is kept < 90°C. The lifetime of the bearings can be increased by the factor 1.5 if the oil is changed after the first 500 service hours and then every 5000 service hours.	See chapter 11.4.9
Lubricants	Synthetic lubricants	See chapter 11.4.9
Motor flange	Aluminium	
Coupling	Insertable, flexible claw coupling, suitable for servo-motors For motor shafts without parallel key Bellows coupling BK For motor shafts with parallel key Bellows coupling BKN	See chapter 11.4.13

Performance data

N ₁ [rpm]	N ₁ MAX [rpm]	3:1			4:1			5:1			6:1			8:1			10:1			12:1			15:1		
		T _{2N} [Nm]	T _{2B} [Nm]	T _{2NOT} [Nm]	T _{2N} [Nm]	T _{2B} [Nm]	T _{2NOT} [Nm]	T _{2N} [Nm]	T _{2B} [Nm]	T _{2NOT} [Nm]	T _{2N} [Nm]	T _{2B} [Nm]	T _{2NOT} [Nm]	T _{2N} [Nm]	T _{2B} [Nm]	T _{2NOT} [Nm]	T _{2N} [Nm]	T _{2B} [Nm]	T _{2NOT} [Nm]	T _{2N} [Nm]	T _{2B} [Nm]	T _{2NOT} [Nm]	T _{2N} [Nm]	T _{2B} [Nm]	T _{2NOT} [Nm]
3900	8000	0	0	0	0	0	0	0	0	0	0	0	0	0	0	0	0	0	0	25	39	51	25	39	51
3200	8000	0	0	0	0	0	0	0	0	0	36	54	72	36	54	72	36	54	72	0	0	0	0	0	0
2100	8000	36	54	72	36	54	72	36	54	72	0	0	0	0	0	0	0	0	0	0	0	0	0	0	0

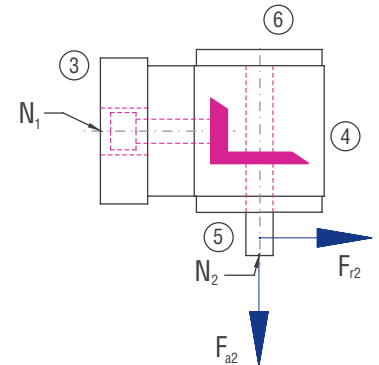

Permissible radial force F_{r2} and axial force F_{a2} on shaft N_2

3:1		4:1		5:1		6:1		8:1		10:1		12:1		15:1	
F_{r2} [N]	F_{a2} [N]	F_{r2} [N]	F_{a2} [N]	F_{r2} [N]	F_{a2} [N]	F_{r2} [N]	F_{a2} [N]	F_{r2} [N]	F_{a2} [N]	F_{r2} [N]	F_{a2} [N]	F_{r2} [N]	F_{a2} [N]	F_{r2} [N]	F_{a2} [N]
3300	1650	3300	1650	3300	1650	3300	1650	3300	1650	3300	1650	3300	1650	3300	1650

Gearbox inertia moments/mass

Inertia moment J_1 related to the fast-rotating shaft (N_1)

Inertia moment [kgcm ²]								Mass ca. [kg]
3:1	4:1	5:1	6:1	8:1	10:1	12:1	15:1	
0,3900	0,3000	0,2300	0,2200	0,1700	0,1500	0,1400	0,1300	3.5

The mass of the gearbox may deviate depending on the type and the gear ratio.

11.4.16 Type HC 090 – Servo hypoid gearboxes

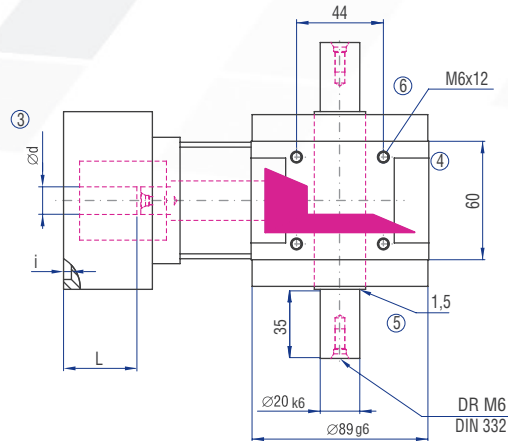
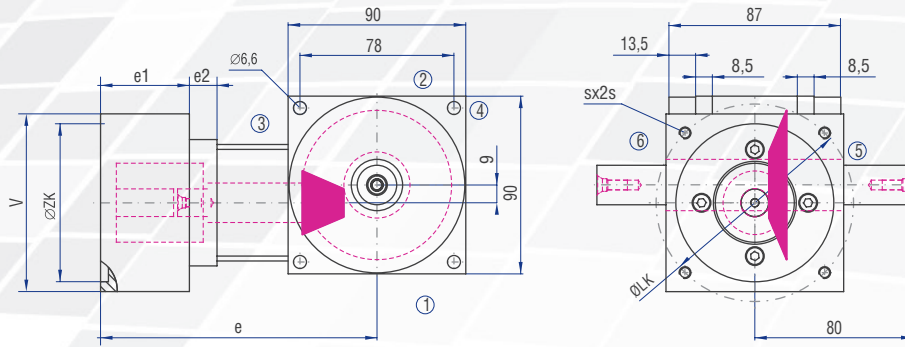
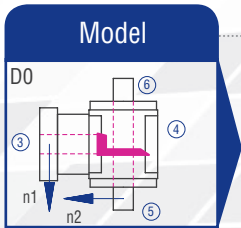
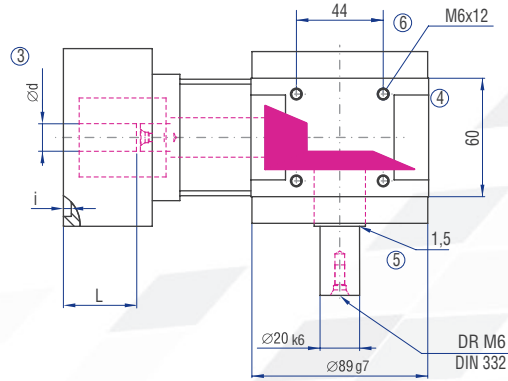
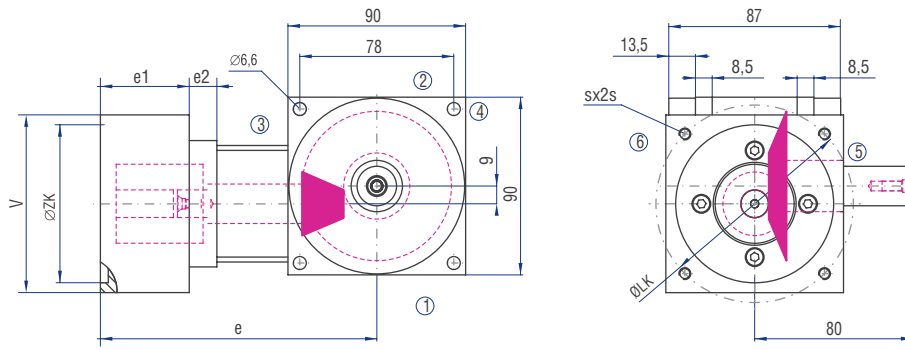
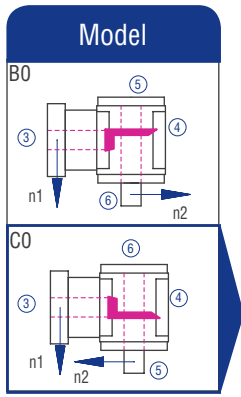

The dimensions of the Models not shown can be figured by mirroring available dimensions.

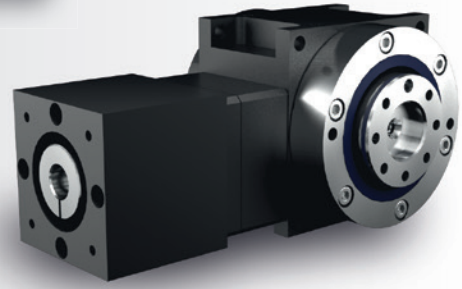

Characteristics

Characteristic	Standard	Option
Toothing	Spiral-toothed, hardened bevel gears	See chapter 11.4.2
Gear ratio	8:1 to 15:1	
Housing / Flanges	Aluminium / steel	
Threaded mounting holes	On the sides 1 and 2 and on the drive flange	See chapter 11.4.4
Shaft	Material 1 C45, shaft ends greased Fit with ISO 6 tolerance	See chapter 4.6.2
Hollow shaft	Material 1 C45, shafts greased Fit with ISO 6 tolerance	See chapter 4.6.3
Radial shaft seal ring	NBR, form A	See chapter 4.8
Ambient temperature	-10°C to +90°C. The values of the performance tables are valid for +20°C	See chapter 4.9.3
Circumferential backlash	< 5 arcmin	See chapter 11.4.11
Protection class	IP 54	See chapter 4.5
Corrosion protection	Prime coat; layer thickness > 40 µm	See chapter 4.4.1
Bearing life L10h	more than 30,000h in S5 operation	See chapter 4.9.1
Oil change intervals	Not required if the oil temperature is kept < 90°C. The lifetime of the bearings can be increased by the factor 1.5 if the oil is changed after the first 500 service hours and then every 5000 service hours.	See chapter 11.4.9
Lubricants	Synthetic lubricants	See chapter 11.4.9
Motor flange	Aluminium	
Coupling	Insertable, flexible claw coupling, suitable for servo-motors For motor shafts without parallel key Bellows coupling BK For motor shafts with parallel key Bellows coupling BKN	See chapter 11.4.13

Performance data

N ₁ [rpm]	N ₁ MAX [rpm]	3:1			4:1			5:1			6:1			8:1			10:1			12:1			15:1		
		T _{2N} [Nm]	T _{2B} [Nm]	T _{2NOT} [Nm]	T _{2N} [Nm]	T _{2B} [Nm]	T _{2NOT} [Nm]	T _{2N} [Nm]	T _{2B} [Nm]	T _{2NOT} [Nm]	T _{2N} [Nm]	T _{2B} [Nm]	T _{2NOT} [Nm]	T _{2N} [Nm]	T _{2B} [Nm]	T _{2NOT} [Nm]	T _{2N} [Nm]	T _{2B} [Nm]	T _{2NOT} [Nm]	T _{2N} [Nm]	T _{2B} [Nm]	T _{2NOT} [Nm]	T _{2N} [Nm]	T _{2B} [Nm]	T _{2NOT} [Nm]
3300	8000	0	0	0	0	0	0	0	0	0	0	0	0	0	0	0	0	0	0	51	77	102	51	77	102
2700	8000	0	0	0	0	0	0	0	0	0	71	107	143	71	107	143	71	107	143	0	0	0	0	0	0
1800	8000	71	107	143	71	107	143	71	107	143	0	0	0	0	0	0	0	0	0	0	0	0	0	0	0

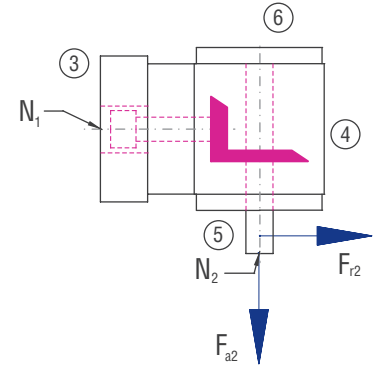

Permissible radial force F_{r2} and axial force F_{a2} on shaft N_2

3:1		4:1		5:1		6:1		8:1		10:1		12:1		15:1	
F_{r2} [N]	F_{a2} [N]	F_{r2} [N]	F_{a2} [N]	F_{r2} [N]	F_{a2} [N]	F_{r2} [N]	F_{a2} [N]	F_{r2} [N]	F_{a2} [N]	F_{r2} [N]	F_{a2} [N]	F_{r2} [N]	F_{a2} [N]	F_{r2} [N]	F_{a2} [N]
4900	2450	4900	2450	4900	2450	4900	2450	4900	2450	4900	2450	4900	2450	4900	2450

Gearbox inertia moments/mass

Inertia moment J_1 related to the fast-rotating shaft (N_1)

Inertia moment [kgcm ²]								Mass ca. [kg]
3:1	4:1	5:1	6:1	8:1	10:1	12:1	15:1	
0,9800	0,7300	0,5800	0,5200	0,4300	0,3800	0,3600	0,3400	5.5

The mass of the gearbox may deviate depending on the type and the gear ratio.

Servo gearboxes
(precision gearboxes)

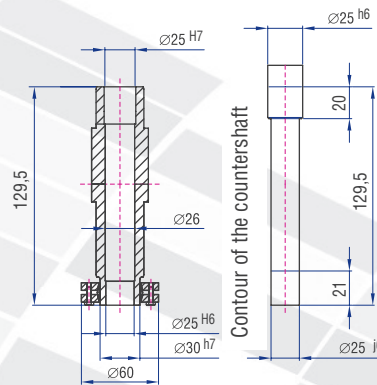
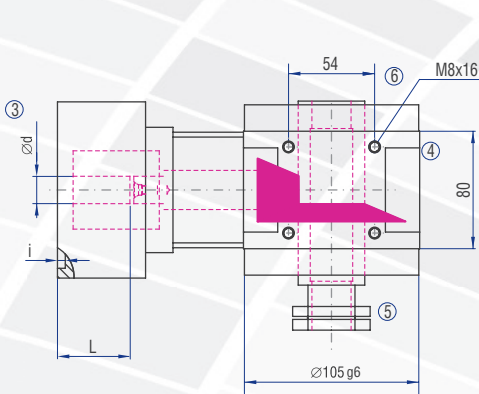
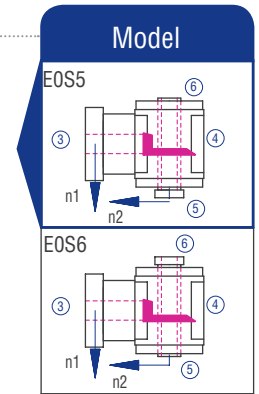
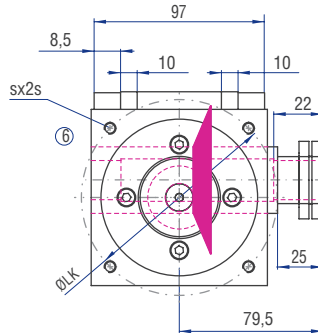
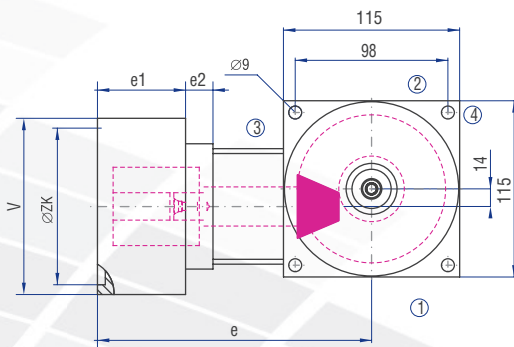
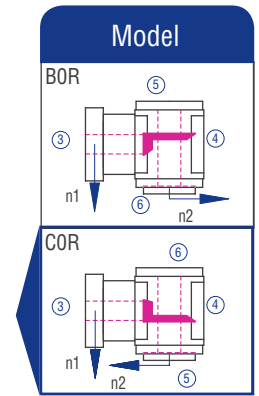
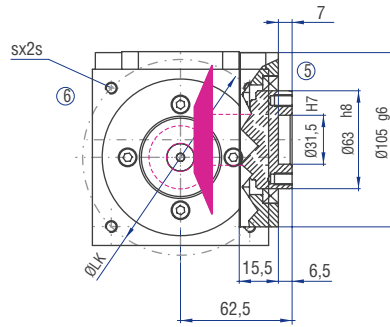
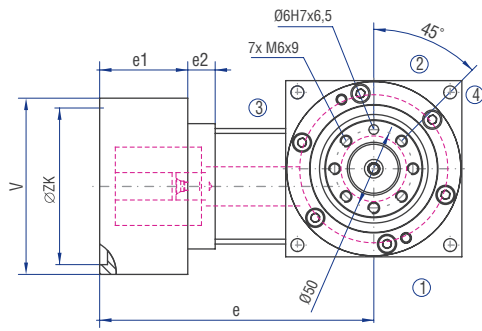

Flange no.	d min [mm]	d max [mm]	L min [mm]	L max [mm]	LK [mm]	ZK [mm]	Thread (s)	□ V [mm]	i [mm]	e [mm]	e1 [mm]	e2 [mm]
001	8	26	24	53	63	40	M4	88	3	177.5	45	46
104	8	26	24	53	75	60	M5	88	3.5	177.5	45	46
301	8	26	24	53	95	50	M6	88	3.5	177.5	45	46
301	10	30	35.5	60	95	50	M6	119	3	184.5	54	44
401	8	26	24	53	100	80	M6	88	4	177.5	45	46
401	10	30	35.5	60	100	80	M6	119	5	184.5	54	44
502	8	26	24	53	115	95	M8	100	4	177.5	45	46
502	10	30	35.5	60	115	95	M8	119	27	184.5	54	44
601	8	26	24	53	130	95	M8	120	4.5	177.5	45	46
601	10	30	35.5	60	130	95	M8	119	27	184.5	54	44
611	8	26	24	53	130	110	M8	115	4.5	177.5	45	46
611	10	30	35.5	60	130	110	M8	119	27	184.5	54	44
701	8	28	24	53	145	110	M8	120	4.5	177.5	45	46
701	10	30	35.5	60	145	110	M8	119	27	184.5	54	44
954	8	26	24	53	90	70	M5	88	4	177.5	45	46
959	8	26	24	53	90	70	M6	88	4	177.5	45	46
959	10	30	40.5	65	145	110	M8	119	32	189.5	59	44
960	10	30	35.5	60	90	70	M6	119	8	184.5	54	44
964	8	26	24	53	70	50	M4	88	4	177.5	45	46
967	10	30	40.5	65	130	110	M8	119	32	189.5	59	44
971	10	30	40.5	65	130	95	M8	119	32	189.5	59	44
972	10	30	42.5	67	100	80	M6	119	5	191.5	61	44
986	8	26	24	53	70	50	M5	88	4	177.5	45	46

Servo gearboxes
(precision gearboxes)

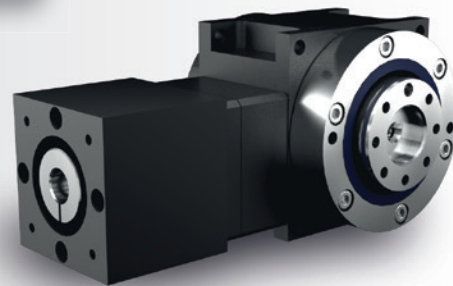

Characteristics

Characteristic	Standard	Option
Toothing	Spiral-toothed, hardened bevel gears	See chapter 11.4.2
Gear ratio	8:1 to 15:1	
Housing / Flanges	Aluminium / steel	
Threaded mounting holes	On the sides 1 and 2 and on the drive flange	See chapter 11.4.4
Shaft	Material 1 C45, shaft ends greased Fit with ISO 6 tolerance	See chapter 4.6.2
Hollow shaft	Material 1 C45, shafts greased Fit with ISO 6 tolerance	See chapter 4.6.3
Radial shaft seal ring	NBR, form A	See chapter 4.8
Ambient temperature	-10°C to +90°C. The values of the performance tables are valid for +20°C	See chapter 4.9.3
Circumferential backlash	< 4 arcmin	See chapter 11.4.11
Protection class	IP 54	See chapter 4.5
Corrosion protection	Prime coat; layer thickness > 40 µm	See chapter 4.4.1
Bearing life L10h	more than 30,000h in S5 operation	See chapter 4.9.1
Oil change intervals	Not required if the oil temperature is kept < 90°C. The lifetime of the bearings can be increased by the factor 1.5 if the oil is changed after the first 500 service hours and then every 5000 service hours.	See chapter 11.4.9
Lubricants	Synthetic lubricants	See chapter 11.4.9
Motor flange	Aluminium	
Coupling	Insertable, flexible claw coupling, suitable for servo-motors For motor shafts without parallel key Bellows coupling BK For motor shafts with parallel key Bellows coupling BKN	See chapter 11.4.13

Performance data

N ₁ [rpm]	N ₁ MAX [rpm]	3:1			4:1			5:1			6:1			8:1			10:1			12:1			15:1		
		T _{2N} [Nm]	T _{2B} [Nm]	T _{2NOT} [Nm]	T _{2N} [Nm]	T _{2B} [Nm]	T _{2NOT} [Nm]	T _{2N} [Nm]	T _{2B} [Nm]	T _{2NOT} [Nm]	T _{2N} [Nm]	T _{2B} [Nm]	T _{2NOT} [Nm]	T _{2N} [Nm]	T _{2B} [Nm]	T _{2NOT} [Nm]	T _{2N} [Nm]	T _{2B} [Nm]	T _{2NOT} [Nm]	T _{2N} [Nm]	T _{2B} [Nm]	T _{2NOT} [Nm]	T _{2N} [Nm]	T _{2B} [Nm]	T _{2NOT} [Nm]
2800	7000	0	0	0	0	0	0	0	0	0	0	0	0	0	0	0	0	0	0	97	145	193	97	145	193
2200	7000	0	0	0	0	0	0	0	0	0	142	215	286	142	215	286	142	215	286	0	0	0	0	0	0
1500	7000	142	215	286	142	215	286	142	215	286	0	0	0	0	0	0	0	0	0	0	0	0	0	0	0

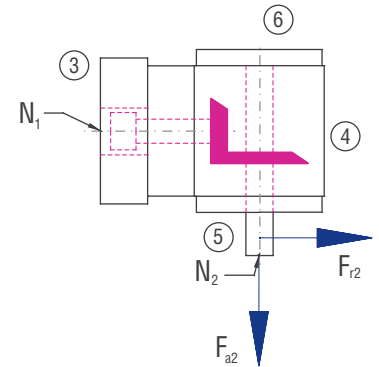

Permissible radial force F_{r2} and axial force F_{a2} on shaft N_2

3:1		4:1		5:1		6:1		8:1		10:1		12:1		15:1	
F_{r2} [N]	F_{a2} [N]	F_{r2} [N]	F_{a2} [N]	F_{r2} [N]	F_{a2} [N]	F_{r2} [N]	F_{a2} [N]	F_{r2} [N]	F_{a2} [N]	F_{r2} [N]	F_{a2} [N]	F_{r2} [N]	F_{a2} [N]	F_{r2} [N]	F_{a2} [N]
7200	3600	7200	3600	7200	3600	7200	3600	7200	3600	7200	3600	7200	3600	7200	3600

Gearbox inertia moments/mass

Inertia moment J_1 related to the fast-rotating shaft (N_1)

Inertia moment [kgcm ²]								Mass ca. [kg]
3:1	4:1	5:1	6:1	8:1	10:1	12:1	15:1	
2,4200	1,7700	1,4100	1,4100	1,1200	1,0000	0,8800	0,8100	9.5

The mass of the gearbox may deviate depending on the type and the gear ratio.

11.4.18 Type HC 140 – Servo hypoid gearboxes

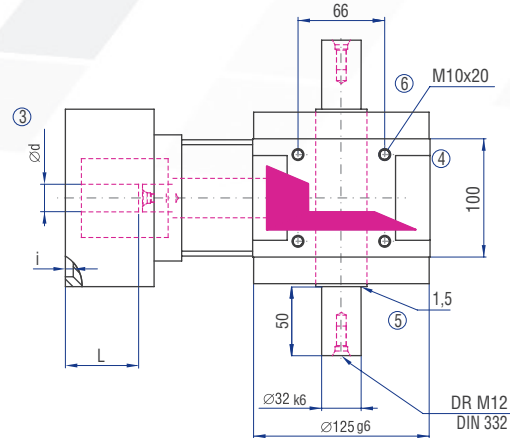
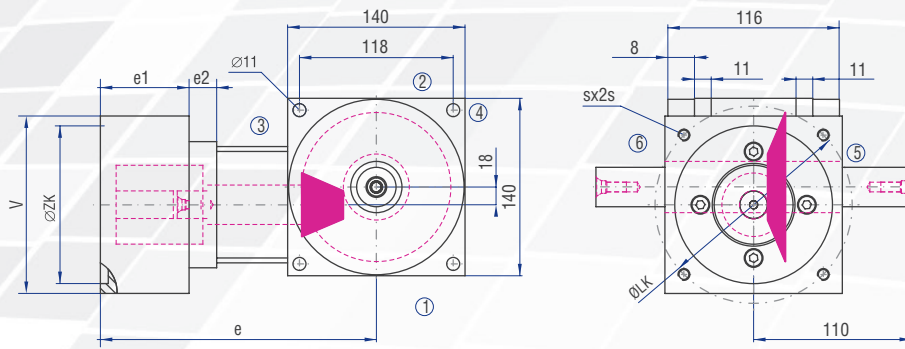
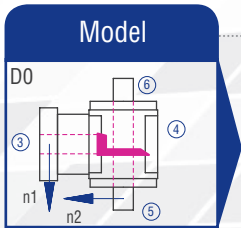
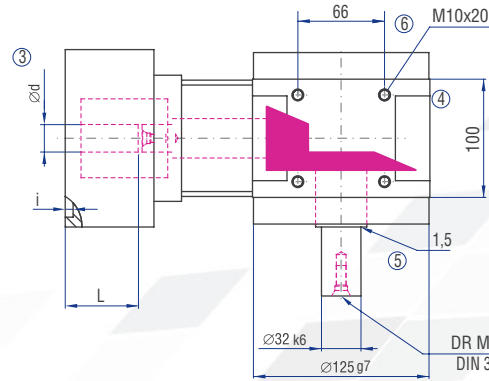
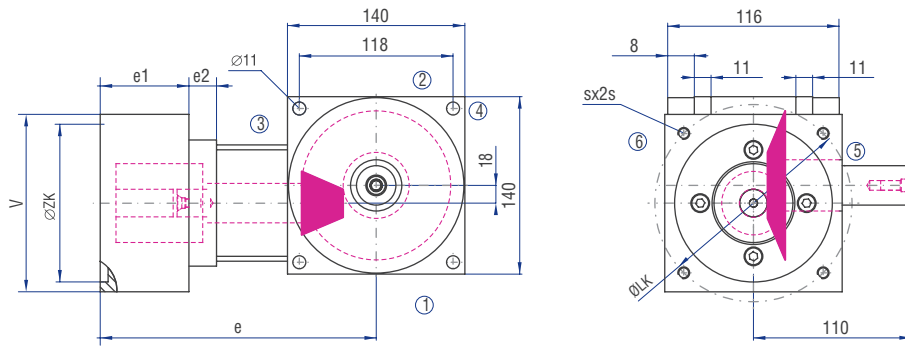
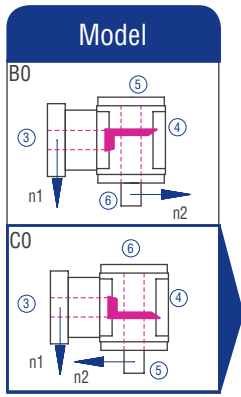

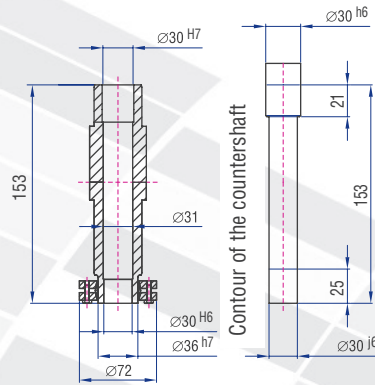
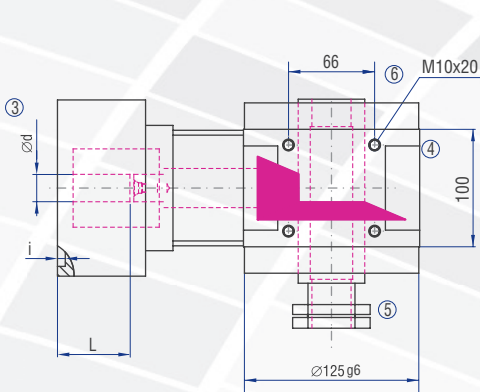
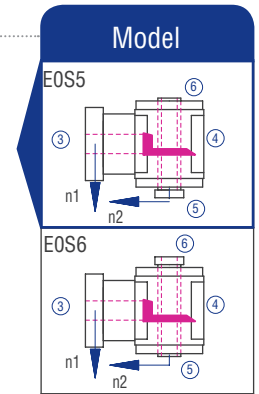
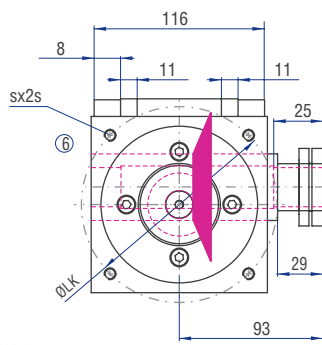
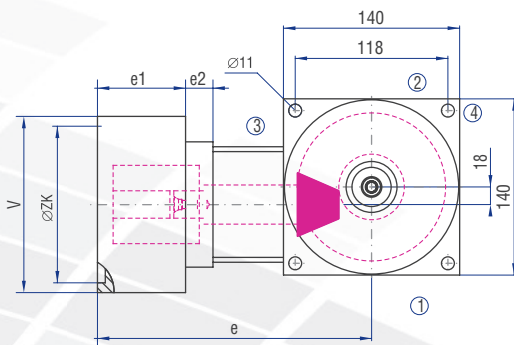
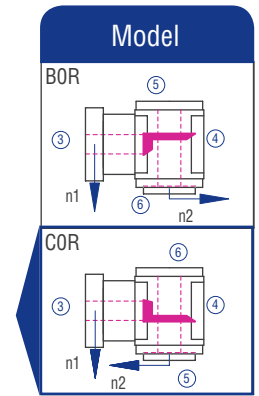
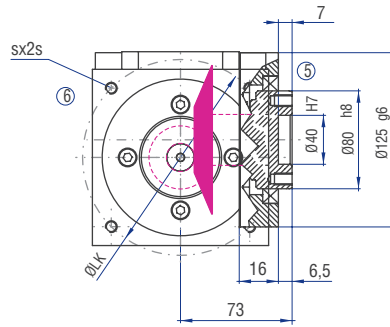
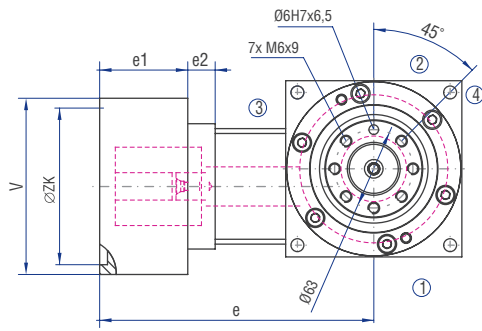

Flange no.	d min [mm]	d max [mm]	L min [mm]	L max [mm]	LK [mm]	ZK [mm]	Thread (s)	□ V [mm]	i [mm]	e [mm]	e1 [mm]	e2 [mm]
301	14	38	31.5	60	95	50	M6	119	3	200	54	50
401	14	38	31.5	60	100	80	M6	119	5	200	54	50
502	14	38	32	60	115	95	M8	137	6	200.5	61	43.5
502	14	38	31.5	60	115	95	M8	119	27	200	54	50
601	14	38	32	60	130	95	M8	137	6	200.5	61	43.5
601	14	38	31.5	60	130	95	M8	119	27	200	54	50
611	14	38	32	60	130	110	M8	137	25	200.5	61	43.5
611	14	38	31.5	60	130	110	M8	119	27	200	54	50
701	14	38	31.5	60	145	110	M8	119	27	200	54	50
802	14	38	32	60	165	110	M10	137	5	200.5	61	43.5
802	14	38	31.5	60	165	110	M10	140	27	200	54	50
811	14	38	32	60	165	130	M10	137	16	200.5	61	43.5
902	14	38	32	60	215	130	M12	200	6	200.5	61	43.5
911	14	38	32	60	215	180	M12	200	5	200.5	61	43.5
932	14	38	52	80	215	180	M12	200	17	220.5	99.5	25
950	14	38	47.5	76	145	110	M8	119	7	216	70	50
951	14	38	37	66	145	110	M8	137	32	205.5	66	43.5
960	14	38	31.5	60	90	70	M6	119	8	200	54	50
972	14	38	38.5	67	100	80	M6	119	5	207	61	50

Servo gearboxes
(precision gearboxes)

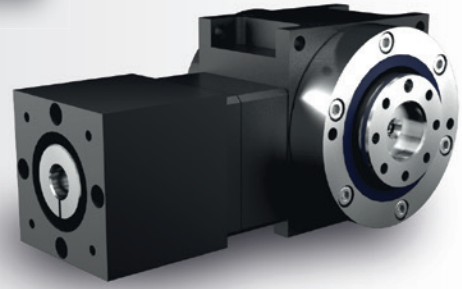

Characteristics

Characteristic	Standard	Option
Toothing	Spiral-toothed, hardened bevel gears	See chapter 11.4.2
Gear ratio	8:1 to 15:1	
Housing / Flanges	Aluminium / steel	
Threaded mounting holes	On the sides 1 and 2 and on the drive flange	See chapter 11.4.4
Shaft	Material 1 C45, shaft ends greased Fit with ISO 6 tolerance	See chapter 4.6.2
Hollow shaft	Material 1 C45, shafts greased Fit with ISO 6 tolerance	See chapter 4.6.3
Radial shaft seal ring	NBR, form A	See chapter 4.8
Ambient temperature	-10°C to +90°C. The values of the performance tables are valid for +20°C	See chapter 4.9.3
Circumferential backlash	< 4 arcmin	See chapter 11.4.11
Protection class	IP 54	See chapter 4.5
Corrosion protection	Prime coat; layer thickness > 40 µm	See chapter 4.4.1
Bearing life L10h	more than 30,000h in S5 operation	See chapter 4.9.1
Oil change intervals	Not required if the oil temperature is kept < 90°C. The lifetime of the bearings can be increased by the factor 1.5 if the oil is changed after the first 500 service hours and then every 5000 service hours.	See chapter 11.4.9
Lubricants	Synthetic lubricants	See chapter 11.4.9
Motor flange	Aluminium	
Coupling	Insertable, flexible claw coupling, suitable for servo-motors For motor shafts without parallel key Bellows coupling BK For motor shafts with parallel key Bellows coupling BKN	See chapter 11.4.13

Performance data

N ₁ [rpm]	N ₁ MAX [rpm]	3:1			4:1			5:1			6:1			8:1			10:1			12:1			15:1		
		T _{2N} [Nm]	T _{2B} [Nm]	T _{2NOT} [Nm]	T _{2N} [Nm]	T _{2B} [Nm]	T _{2NOT} [Nm]	T _{2N} [Nm]	T _{2B} [Nm]	T _{2NOT} [Nm]	T _{2N} [Nm]	T _{2B} [Nm]	T _{2NOT} [Nm]	T _{2N} [Nm]	T _{2B} [Nm]	T _{2NOT} [Nm]	T _{2N} [Nm]	T _{2B} [Nm]	T _{2NOT} [Nm]	T _{2N} [Nm]	T _{2B} [Nm]	T _{2NOT} [Nm]	T _{2N} [Nm]	T _{2B} [Nm]	T _{2NOT} [Nm]
2300	6000	0	0	0	0	0	0	0	0	0	0	0	0	0	0	0	0	0	0	182	275	365	182	275	365
1800	6000	0	0	0	0	0	0	0	0	0	266	398	528	266	398	528	266	398	528	0	0	0	0	0	0
1150	6000	266	398	528	266	398	528	266	398	528	0	0	0	0	0	0	0	0	0	0	0	0	0	0	0

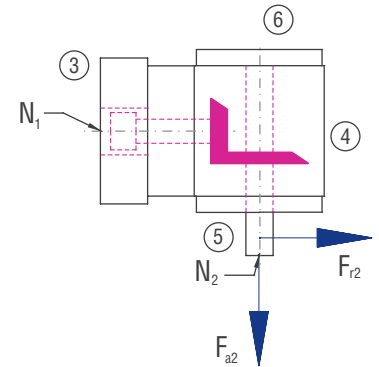

Permissible radial force F_{r2} and axial force F_{a2} on shaft N_2

3:1		4:1		5:1		6:1		8:1		10:1		12:1		15:1	
F_{r2} [N]	F_{a2} [N]	F_{r2} [N]	F_{a2} [N]	F_{r2} [N]	F_{a2} [N]	F_{r2} [N]	F_{a2} [N]	F_{r2} [N]	F_{a2} [N]	F_{r2} [N]	F_{a2} [N]	F_{r2} [N]	F_{a2} [N]	F_{r2} [N]	F_{a2} [N]
10000	5000	10000	5000	10000	5000	10000	5000	10000	5000	10000	5000	10000	5000	10000	5000

Gearbox inertia moments/mass

Inertia moment J_1 related to the fast-rotating shaft (N_1)

Inertia moment [kgcm ²]								Mass ca. [kg]
3:1	4:1	5:1	6:1	8:1	10:1	12:1	15:1	
7,1200	5,0900	4,0000	3,6500	2,8500	2,4600	2,2500	2,0700	15.5

The mass of the gearbox may deviate depending on the type and the gear ratio.

Servo gearboxes
(precision gearboxes)

11.4.19 Type HC 170 – Servo hypoid gearboxes

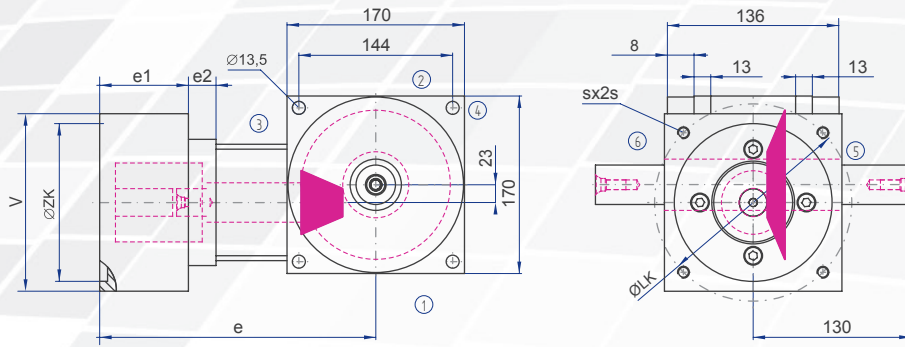
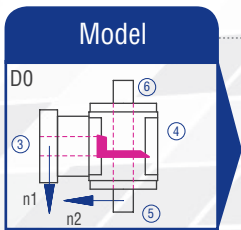
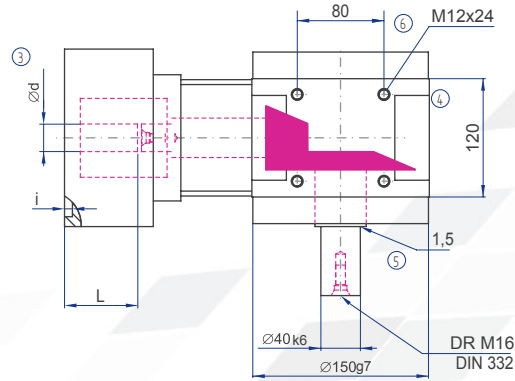
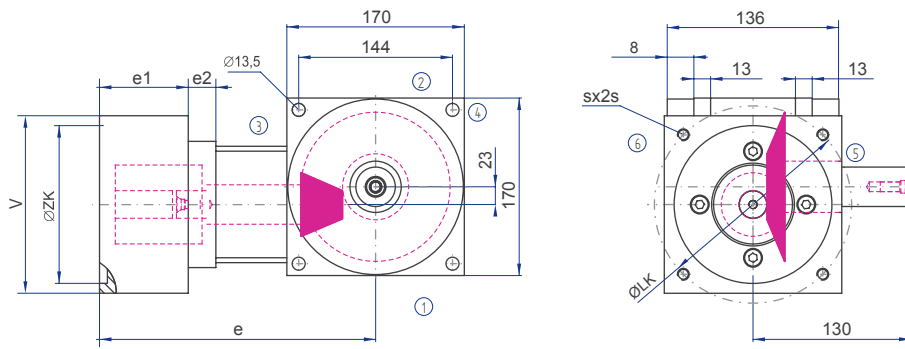
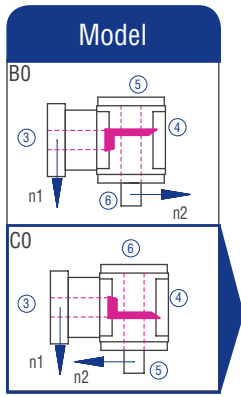

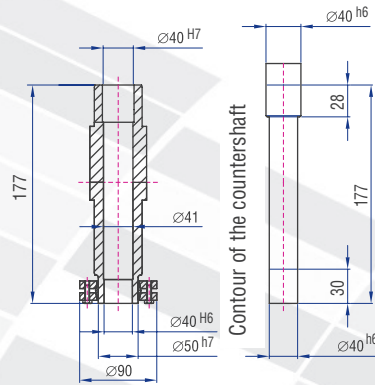
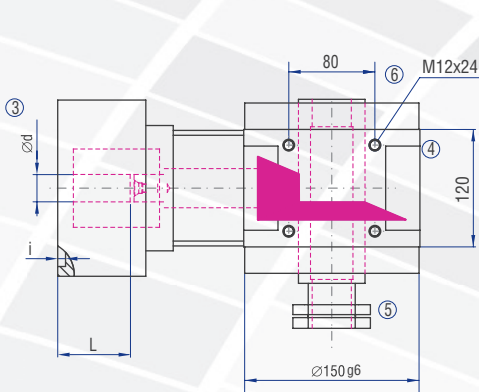
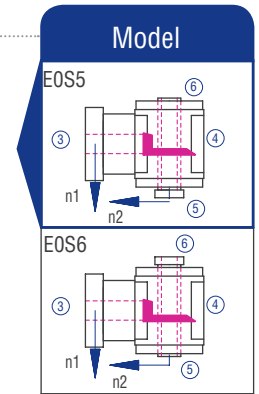
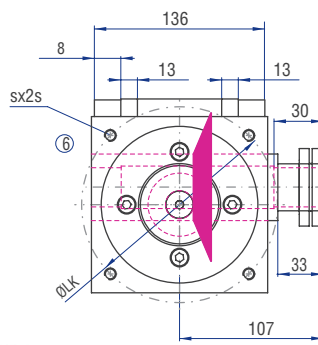
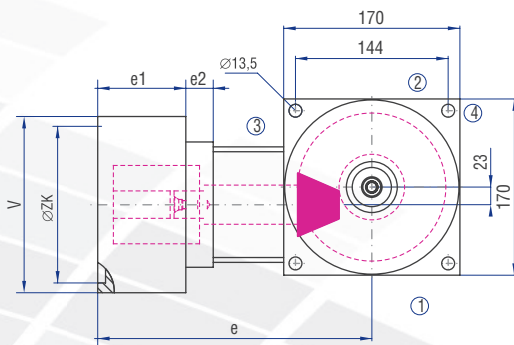
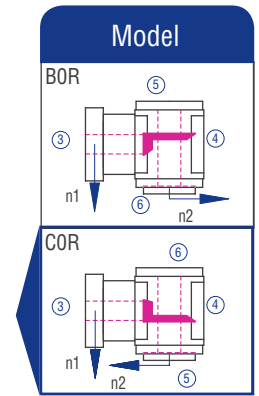
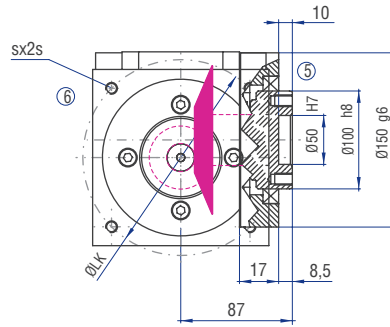
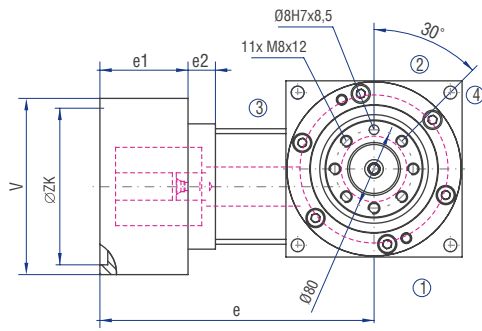

Flange no.	d min [mm]	d max [mm]	L min [mm]	L max [mm]	LK [mm]	ZK [mm]	Thread (s)	□ V [mm]	i [mm]	e [mm]	e1 [mm]	e2 [mm]
502	19	42	39	65	115	95	M8	137	6	226.5	61	53.5
601	19	42	39	65	130	95	M8	137	6	226.5	61	53.5
611	19	42	39	65	130	110	M8	137	25	226.5	61	53.5
802	19	42	39	65	165	110	M10	137	5	226.5	61	53.5
811	19	42	39	65	165	130	M10	137	16	226.5	61	53.5
811	19	42	46	80	165	130	M10	157	5	242	62	68
902	19	42	39	65	215	130	M12	200	6	226.5	61	53.5
902	19	42	46	80	215	130	M12	200	5	242	62	68
911	19	42	39	65	215	180	M12	200	5	226.5	61	53.5
912	19	42	46	80	215	180	M12	200	5	242	62	68
931	19	42	84	110	215	180	M12	200	17	271.5	106	53.5
932	19	42	77.5	103	215	180	M12	200	17	265	99.5	53.5
951	19	42	44	70	145	110	M8	137	32	231.5	66	53.5
952	19	42	46	80	200	114.3	M12	200	6	242	62	68
952	19	42	84	110	200	114.3	M12	200	6	271.5	106	53.5

Servo gearboxes
(precision gearboxes)

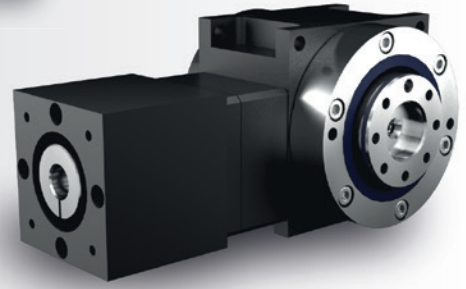

Characteristics

Characteristic	Standard	Option
Toothing	Spiral-toothed, hardened bevel gears	See chapter 11.4.2
Gear ratio	8:1 to 15:1	
Housing / Flanges	Aluminium / steel	
Threaded mounting holes	On the sides 1 and 2 and on the drive flange	See chapter 11.4.4
Shaft	Material 1 C45, shaft ends greased Fit with ISO 6 tolerance	See chapter 4.6.2
Hollow shaft	Material 1 C45, shafts greased Fit with ISO 6 tolerance	See chapter 4.6.3
Radial shaft seal ring	NBR, form A	See chapter 4.8
Ambient temperature	-10°C to +90°C. The values of the performance tables are valid for +20°C	See chapter 4.9.3
Circumferential backlash	< 4 arcmin	See chapter 11.4.11
Protection class	IP 54	See chapter 4.5
Corrosion protection	Prime coat; layer thickness > 40 µm	See chapter 4.4.1
Bearing life L10h	more than 30,000h in S5 operation	See chapter 4.9.1
Oil change intervals	Not required if the oil temperature is kept < 90°C. The lifetime of the bearings can be increased by the factor 1.5 if the oil is changed after the first 500 service hours and then every 5000 service hours.	See chapter 11.4.9
Lubricants	Synthetic lubricants	See chapter 11.4.9
Motor flange	Aluminium	
Coupling	Insertable, flexible claw coupling, suitable for servo-motors For motor shafts without parallel key Bellows coupling BK For motor shafts with parallel key Bellows coupling BKN	See chapter 11.4.13

Performance data

N ₁ [rpm]	N ₁ MAX [rpm]	3:1			4:1			5:1			6:1			8:1			10:1			12:1			15:1		
		T _{2N} [Nm]	T _{2B} [Nm]	T _{2NOT} [Nm]	T _{2N} [Nm]	T _{2B} [Nm]	T _{2NOT} [Nm]	T _{2N} [Nm]	T _{2B} [Nm]	T _{2NOT} [Nm]	T _{2N} [Nm]	T _{2B} [Nm]	T _{2NOT} [Nm]	T _{2N} [Nm]	T _{2B} [Nm]	T _{2NOT} [Nm]	T _{2N} [Nm]	T _{2B} [Nm]	T _{2NOT} [Nm]	T _{2N} [Nm]	T _{2B} [Nm]	T _{2NOT} [Nm]	T _{2N} [Nm]	T _{2B} [Nm]	T _{2NOT} [Nm]
1600	5000	0	0	0	0	0	0	0	0	0	0	0	0	0	0	0	0	0	0	512	767	1022	512	767	1022
1200	5000	0	0	0	0	0	0	0	0	0	723	1084	1450	723	1084	1450	723	1084	1450	0	0	0	0	0	0
700	5000	723	1084	1450	723	1084	1450	723	1084	1450	0	0	0	0	0	0	0	0	0	0	0	0	0	0	0

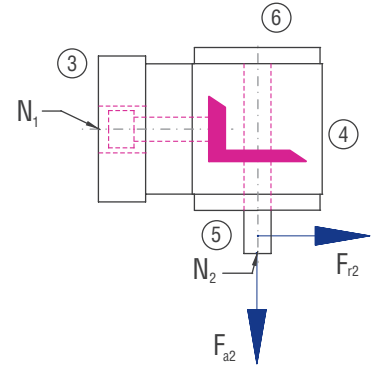

Permissible radial force F_{r2} and axial force F_{a2} on shaft N₂

3:1		4:1		5:1		6:1		8:1		10:1		12:1		15:1	
F _{r2} [N]	F _{a2} [N]	F _{r2} [N]	F _{a2} [N]	F _{r2} [N]	F _{a2} [N]	F _{r2} [N]	F _{a2} [N]	F _{r2} [N]	F _{a2} [N]	F _{r2} [N]	F _{a2} [N]	F _{r2} [N]	F _{a2} [N]	F _{r2} [N]	F _{a2} [N]
15000	7500	15000	7500	15000	7500	15000	7500	15000	7500	15000	7500	15000	7500	15000	7500

Gearbox inertia moments/mass

Inertia moment J₁ related to the fast-rotating shaft (N₁)

Inertia moment [kgcm ²]								Mass ca. [kg]
3:1	4:1	5:1	6:1	8:1	10:1	12:1	15:1	
26,9600	17,4400	13,5300	12,2500	8,9500	7,3800	6,4700	5,7600	32.5

The mass of the gearbox may deviate depending on the type and the gear ratio.

Servo gearboxes
(precision gearboxes)

11.4.20 Type HC 215 – Servo hypoid gearboxes

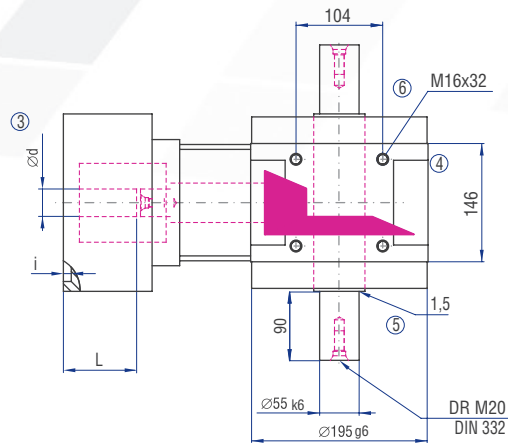
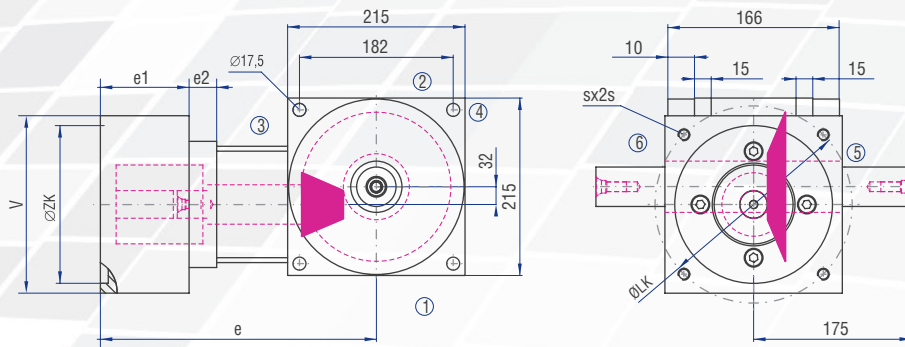
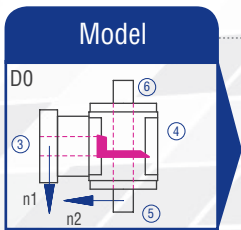
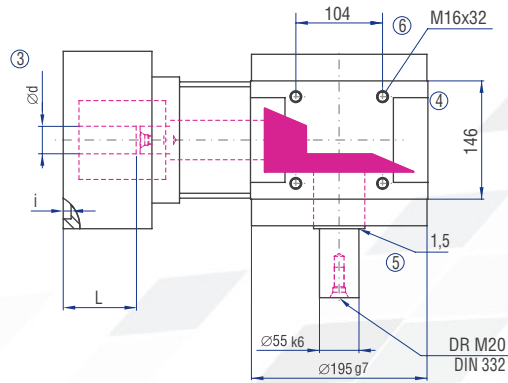
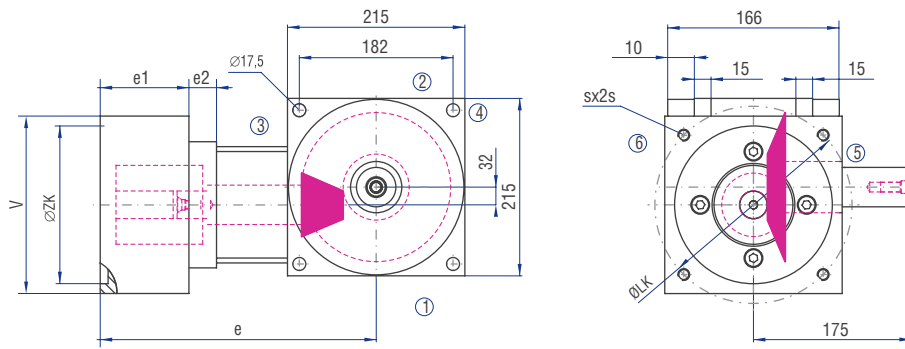
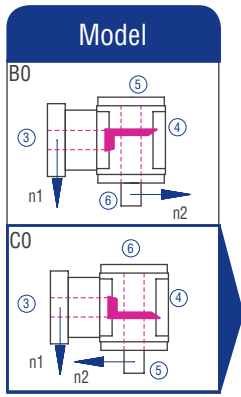

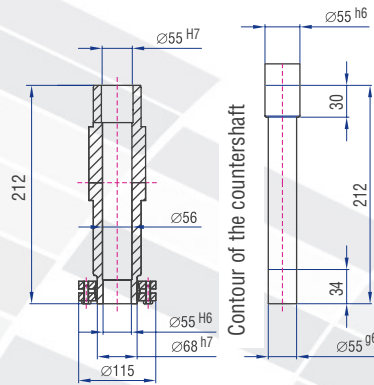
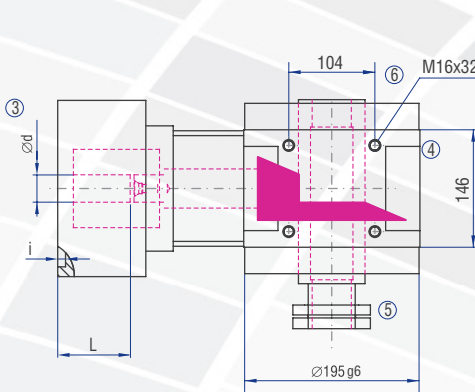
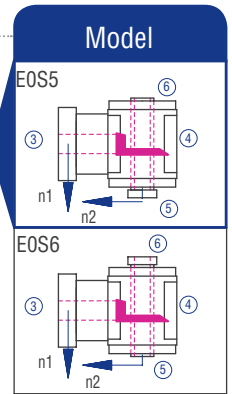
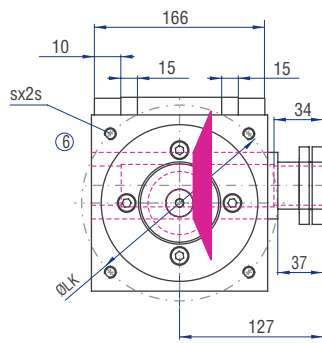
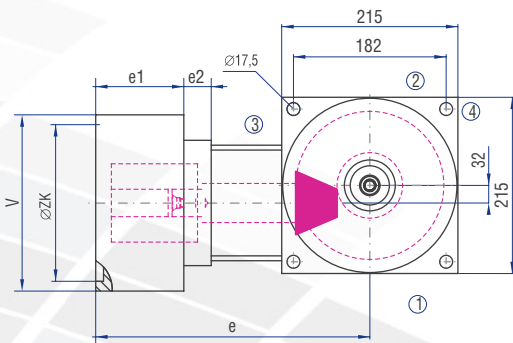
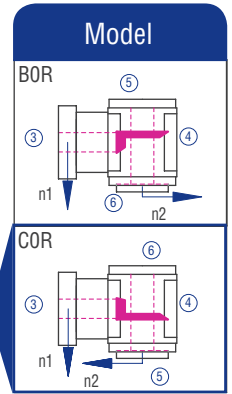
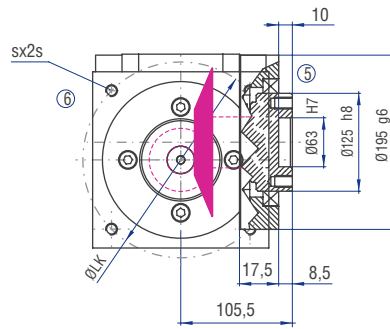
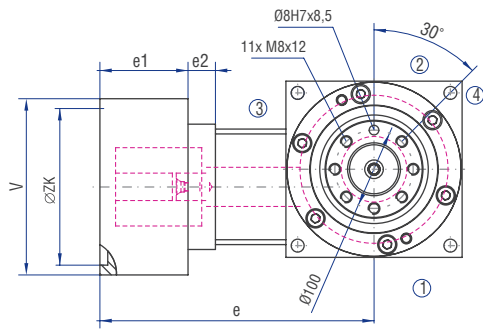

Flange no.	d min [mm]	d max [mm]	L min [mm]	L max [mm]	LK [mm]	ZK [mm]	Thread (s)	□ V [mm]	i [mm]	e [mm]	e1 [mm]	e2 [mm]
811	24	60	44.5	82	165	130	M10	198	5	280.5	76	59
902	24	60	44.5	82	215	130	M12	198	5	280.5	76	59
913	24	60	44.5	82	215	180	M12	198	4.5	280.5	76	59
952	24	60	56.5	94	200	114.3	M12	198	10	292.5	88	59
960	24	60	72.5	110	300	250	M16	264	7	308.5	141	22
961	24	60	56.5	94	265	230	M12	264	6	292.5	88	59
963	24	60	79.5	117	215	180	M12	198	4.5	315.5	111	59

Servo gearboxes
(precision gearboxes)

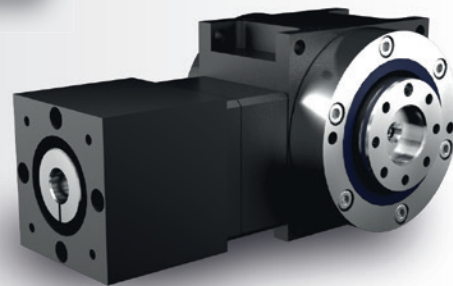

Characteristics

Characteristic	Standard	Option
Toothing	Spiral-toothed, hardened bevel gears	See chapter 11.4.2
Gear ratio	8:1 to 15:1	
Housing / Flanges	Aluminium / steel	
Threaded mounting holes	On the sides 1 and 2 and on the drive flange	See chapter 11.4.4
Shaft	Material 1 C45, shaft ends greased Fit with ISO 6 tolerance	See chapter 4.6.2
Hollow shaft	Material 1 C45, shafts greased Fit with ISO 6 tolerance	See chapter 4.6.3
Radial shaft seal ring	NBR, form A	See chapter 4.8
Ambient temperature	-10°C to +90°C. The values of the performance tables are valid for +20°C	See chapter 4.9.3
Circumferential backlash	< 4 arcmin	See chapter 11.4.11
Protection class	IP 54	See chapter 4.5
Corrosion protection	Prime coat; layer thickness > 40 µm	See chapter 4.4.1
Bearing life L10h	more than 30,000h in S5 operation	See chapter 4.9.1
Oil change intervals	Not required if the oil temperature is kept < 90°C. The lifetime of the bearings can be increased by the factor 1.5 if the oil is changed after the first 500 service hours and then every 5000 service hours.	See chapter 11.4.9
Lubricants	Synthetic lubricants	See chapter 11.4.9
Motor flange	Aluminium	
Coupling	Insertable, flexible claw coupling, suitable for servo-motors For motor shafts without parallel key Bellows coupling BK For motor shafts with parallel key Bellows coupling BKN	See chapter 11.4.13

Performance data

N ₁ [rpm]	N ₁ MAX [rpm]	3:1			4:1			5:1			6:1			8:1			10:1			12:1			15:1		
		T _{2N} [Nm]	T _{2B} [Nm]	T _{2NOT} [Nm]	T _{2N} [Nm]	T _{2B} [Nm]	T _{2NOT} [Nm]	T _{2N} [Nm]	T _{2B} [Nm]	T _{2NOT} [Nm]	T _{2N} [Nm]	T _{2B} [Nm]	T _{2NOT} [Nm]	T _{2N} [Nm]	T _{2B} [Nm]	T _{2NOT} [Nm]	T _{2N} [Nm]	T _{2B} [Nm]	T _{2NOT} [Nm]	T _{2N} [Nm]	T _{2B} [Nm]	T _{2NOT} [Nm]	T _{2N} [Nm]	T _{2B} [Nm]	T _{2NOT} [Nm]
1300	4500	0	0	0	0	0	0	0	0	0	0	0	0	0	0	0	0	0	0	1023	1533	2044	1023	1533	2044
1000	4500	0	0	0	0	0	0	0	0	0	0	1444	2165	2880	1444	2165	2880	1444	2165	2880	0	0	0	0	0
550	4500	1444	2165	2880	1444	2165	2880	1444	2165	2880	0	0	0	0	0	0	0	0	0	0	0	0	0	0	0

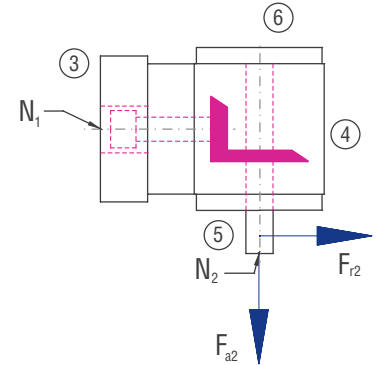

Permissible radial force F_{r2} and axial force F_{a2} on shaft N_2

3:1		4:1		5:1		6:1		8:1		10:1		12:1		15:1	
F_{r2} [N]	F_{a2} [N]	F_{r2} [N]	F_{a2} [N]	F_{r2} [N]	F_{a2} [N]	F_{r2} [N]	F_{a2} [N]	F_{r2} [N]	F_{a2} [N]	F_{r2} [N]	F_{a2} [N]	F_{r2} [N]	F_{a2} [N]	F_{r2} [N]	F_{a2} [N]
22500	11250	22500	11250	22500	11250	22500	11250	22500	11250	22500	11250	22500	11250	22500	11250

Gearbox inertia moments/mass

Inertia moment J_1 related to the fast-rotating shaft (N_1)

Inertia moment [kgcm ²]								Mass ca. [kg]
3:1	4:1	5:1	6:1	8:1	10:1	12:1	15:1	
91,4700	62,4300	44,2900	39,5500	27,0700	21,4300	18,1400	15,5300	60

The mass of the gearbox may deviate depending on the type and the gear ratio.

Servo gearboxes
(precision gearboxes)

11.4.21 Type HC 260 – Servo hypoid gearboxes

