





Linear system **MLN 60, 60S**

NUBBED BELT DRIVE

-  INDEPENDENT INSTALLATION POSITION
-  NOBBED BELT
-  LOW OPERATING VOLUME
-  PRECISION

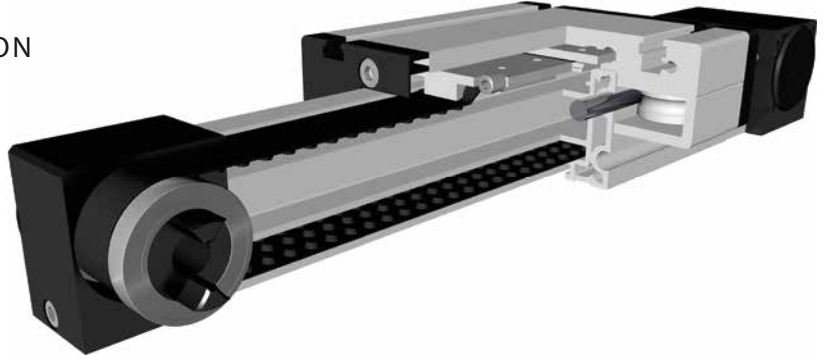

5.1

Function:

The guide body consists of an aluminium square profile with lateral, parallel, form-fit, internal hardened steel rods. The guide carriage, which is driven along the shafts by a nubbled belt, moves on the guide body with internal linear ball bearings that are adjustable free of play. The advantage of this system: The belt is guided within the profile, so that the system is independent of the mounting position. The nubbled belt is self-tracking and has a very low operating noise level thanks to its nobs being offset by 45°. Furthermore, it is almost vibration-free in the transition sections.

Fitting position:

As required, max. length 6.000 mm without joints.

Carriage mounting:

By T-slots.

Unit mounting:

By T-slots or tapped holes in the bearing block, mounting sets.

Belt type:

N10 with steel reinforcement, no backlash when changing direction, repeatability: ± 0,1 mm.

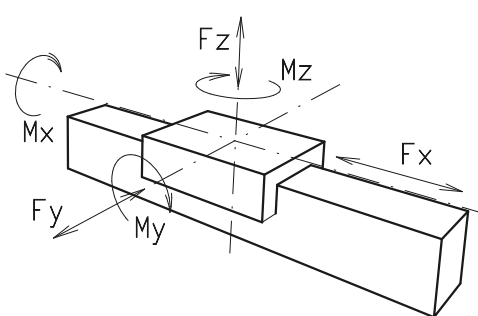
Forces and torques	Size	60		60 S	
	Forces/Torques	static	dynamic	static	dynamic
	F _x (N)	1950	1300	1950	1300
	F _y (N)	3000	2000	4100	3100
	F _z (N)	1700	1100	2160	1600
	M _x (Nm)	67	43	88	65
	M _y (Nm)	90	70	190	140
	M _z (Nm)	120	100	230	170
All forces and torques relate to the following:					
existing values $\frac{F_y}{F_{y_{dyn}}} + \frac{F_z}{F_{z_{dyn}}} + \frac{M_x}{M_{x_{dyn}}} + \frac{M_y}{M_{y_{dyn}}} + \frac{M_z}{M_{z_{dyn}}} \leq 1$					
table values $\frac{F_y}{F_{y_{dyn}}} + \frac{F_z}{F_{z_{dyn}}} + \frac{M_x}{M_{x_{dyn}}} + \frac{M_y}{M_{y_{dyn}}} + \frac{M_z}{M_{z_{dyn}}} \leq 1$					
No-load torque					
Nm		0,6		0,7	
Speed					
(m/s) max		5		7	
Tensile force					
permanent (N)		1050		1050	
0,2 s (N)		1150		1150	
Geometrical moments of inertia of aluminium profile					
I _x mm ⁴		4,67x10 ⁵		4,67x10 ⁵	
I _y mm ⁴		5,21x10 ⁵		5,21x10 ⁵	
E-Modulus N/mm ²		70000		70000	

For life-time calculation of rollers use our homepage.

Driving torque:

$$M_o = \frac{F \cdot P \cdot S_i}{2000 \cdot \pi} + M_n$$

$$P_o = \frac{M_o \cdot n}{9550}$$

- F = force (N)
- P = pulley action perimeter (mm)
- S_i = safety factor 1,2 ... 2
- M_n = no-load torque (Nm)
- n = rpm pulley (min⁻¹)
- M_o = driving torque (Nm)
- P_o = motor power (KW)

Deflection:

$$f = \frac{F \cdot L^3}{E \cdot I \cdot 192}$$

- f = deflection (mm)
- F = load (N)
- L = free length (mm)
- E = elastic modulus 70000 (N/mm²)
- I = second moment of area (mm⁴)

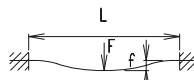

Linear system MLN 60, 60S

Dimensions (mm)

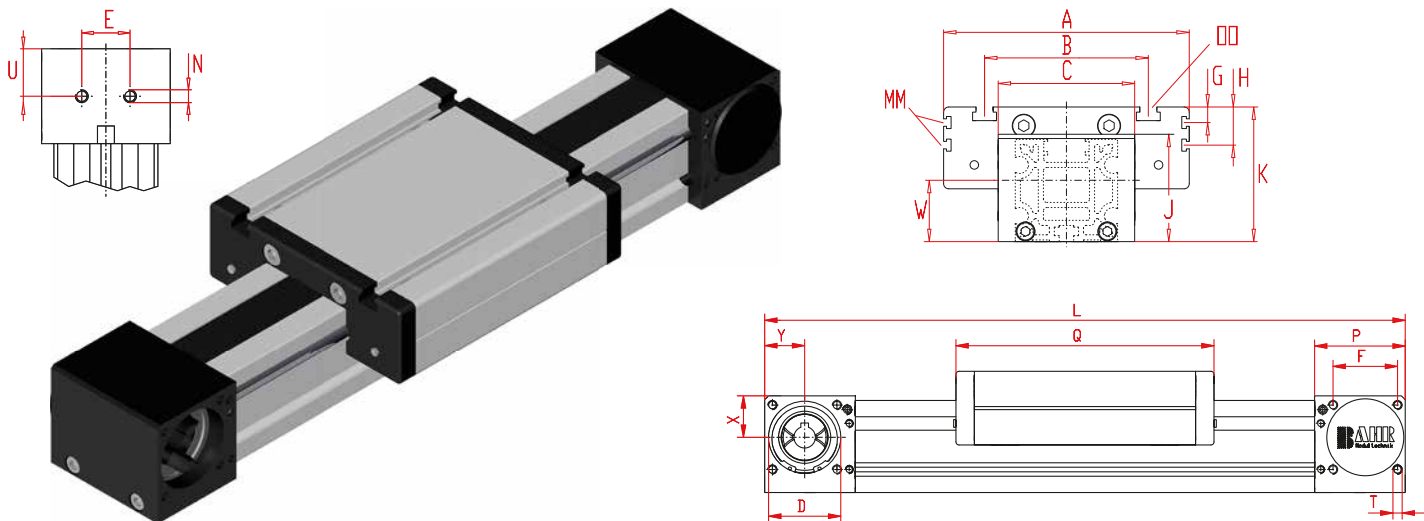

5.1

*For slide nuts refer to chapter 2.2 page 2

Increasing the carriage length will increase the basic length by the same amount.

Size	Basic length L	A	B	C	D -0,05	E	F	J	K	N	OO for	P	Q	T	U	W	X	Y	Basic weight	Weight per 100 mm
MLN 60	290	144	96	80	47	30	42	63	79	M 8	M 8	59	168	M 6	29,5	30	27	26	4,7 kg	0,6 kg
MLN 60S	315	170	108	80	47	30	42	63	83	M 8	M 8	59	194	M 6	29,5	30	27	26	5,7 kg	0,6 kg

0 Choice of guide body profile:

- (0) Standard (2) corrosion-protected guide rods and screws
- (4) expanded corrosion-protected version (depending on the availability of components)

0 Choice of carriages:

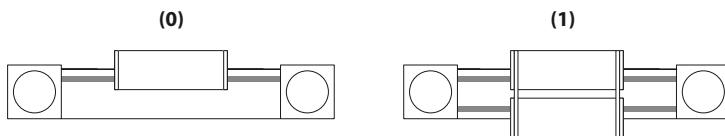

Size	Version 1	
	Q	L
60	184	306
60S	214	336

0 Drive version:

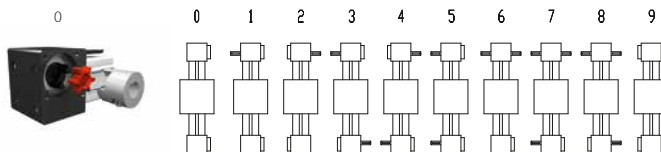

Version 9 is the same as 0, but with double sided coupling claw.

The standard version is supplied without shaft.

Belt table

Code No.	Size	Belt	mm/rev.	Number of teeth
0 8	60 (S)	Nobbed belt N10	130	13/3

Shaft dimensions / Coupling claw

Size	Shaft ø h6 x length	Key	Coupling
60 (S)	14 x 35	5x5x28	14

MLN 60 1 0 0 0 0 8 1 1500

Basic length + stroke = total length

For combination kits and connecting elements refer to chapter 2.2

Sample ordering code:

MLN 60, standard body profile, standard carriage, drive version 0, knobbelt belt, 1210 mm stroke

