





# Linear system **GDGK 90**

1.1

## SPINDLE DRIVEN

-  EX-GUIDE
-  LIFTING SYSTEM
-  HIGH RIGIDITY
-  EASY CLEANING
-  SMOOTH SURFACES

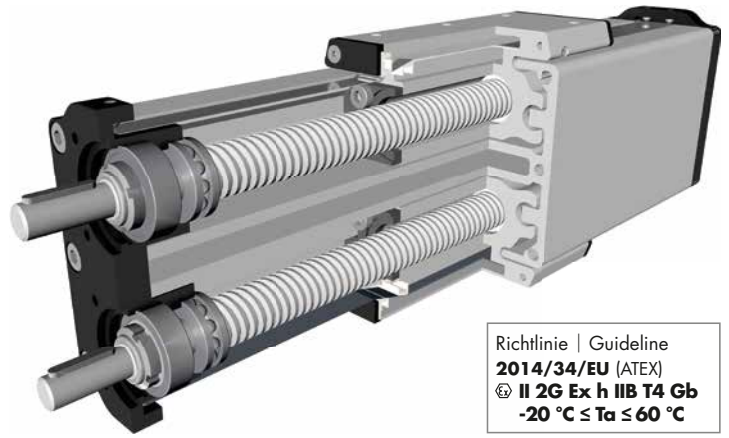
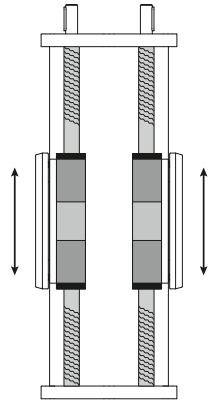

Richlinie | Guideline  
**2014/34/EU** (ATEX)  
 Ⓜ II 2G Ex h IIB T4 Gb  
 -20 °C ≤ Ta ≤ 60 °C

### Function:

Optimized spindle axis for lift systems, bicycle assembly stands, lifting platforms and other lifting applications. The guide body consists of an aluminium profile with an integrated sliding guide. The plastic slide bushes integrated in the carriage ensure a very low friction resistance on anodized aluminium. The so-called double G profile ensures a very high stability. The carriage is moved by a rotating threaded spindle provided with a follower nut. The opening in the guide body is closed by a cover band. This cover band prevents dust and dirt from getting inside, it also offers a high level of safety and protects against hand injuries.

### The products can be used as follows, according to the marking:

- a) In Zone 2 (Gas, Category 3G, EPL Gc) in explosion groups IIA and IIB
- b) In Zone 1 (Gas, Category 2G, EPL Gb) in explosion groups IIA and IIB

The qualification with regard to the surface temperature is T4; for all gases, vapours and mists with an ignition temperature > 125 °C the product is not an ignition source.

### Fitting position:

As required. Max. length 1.500 mm

### Carriage mounting:

By tapped holes in the carriage.

### Unit mounting:

By T-slots or tapped holes in the bearing block and mounting sets.

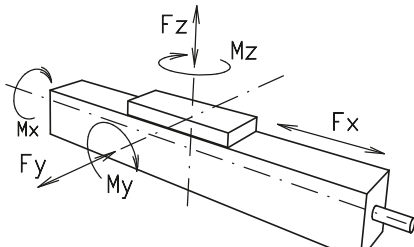
Forces and torques	Size		
	90		
	Forces / Torques		
	$F_x$ (N)	static	dynamic
	$F_y$ (N)	1000	1500
	$F_z$ (N)	1000	900
	$M_x$ (Nm)	1125	1000
	$M_y$ (Nm)	67	62
	$M_z$ (Nm)	180	165
	$M_z$ (Nm)	135	124
<b>All forces and torques relate to the following:</b>			
existing values	$\frac{F_y}{F_{y_{dyn}}} + \frac{F_z}{F_{z_{dyn}}} + \frac{M_x}{M_{x_{dyn}}} + \frac{M_y}{M_{y_{dyn}}} + \frac{M_z}{M_{z_{dyn}}} \leq 1$		
table values			
<b>No-load torque</b>			
	Ballscrew	25x10	
	(Nm)	0,60	
<b>Geometrical moments of inertia of aluminium profile</b>			
	$I_x$ mm <sup>4</sup>	4,1x10 <sup>6</sup>	
	$I_y$ mm <sup>4</sup>	4,0x10 <sup>6</sup>	
	Elastic-modulus N/mm <sup>2</sup>	70000	

Driving torque:

$$M_o = \frac{F \cdot P \cdot S_i}{2000 \cdot \pi \cdot \mu} + M_n$$

$$P_o = \frac{M_o \cdot n}{9550}$$

F = force (N)  
 P = thread pitch (mm)  
 Si = safety factor 1,2 ... 2  
 Mn = no-load torque (Nm)  
 n = rpm of screw (min<sup>-1</sup>)  
 Mo = driving torque (Nm)  
 μ = screw efficiency  
 Po = motor power (KW)

Efficiency of lead screws:

All ballscrew 0,900

Deflection:

$$f = \frac{F \cdot L^3}{E \cdot I \cdot 192}$$

f = deflection (mm)  
 F = load (N)  
 L = free length (mm)  
 E = elastic modulus 70000 (N/mm<sup>2</sup>)  
 I = second moment of area (mm<sup>4</sup>)

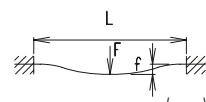

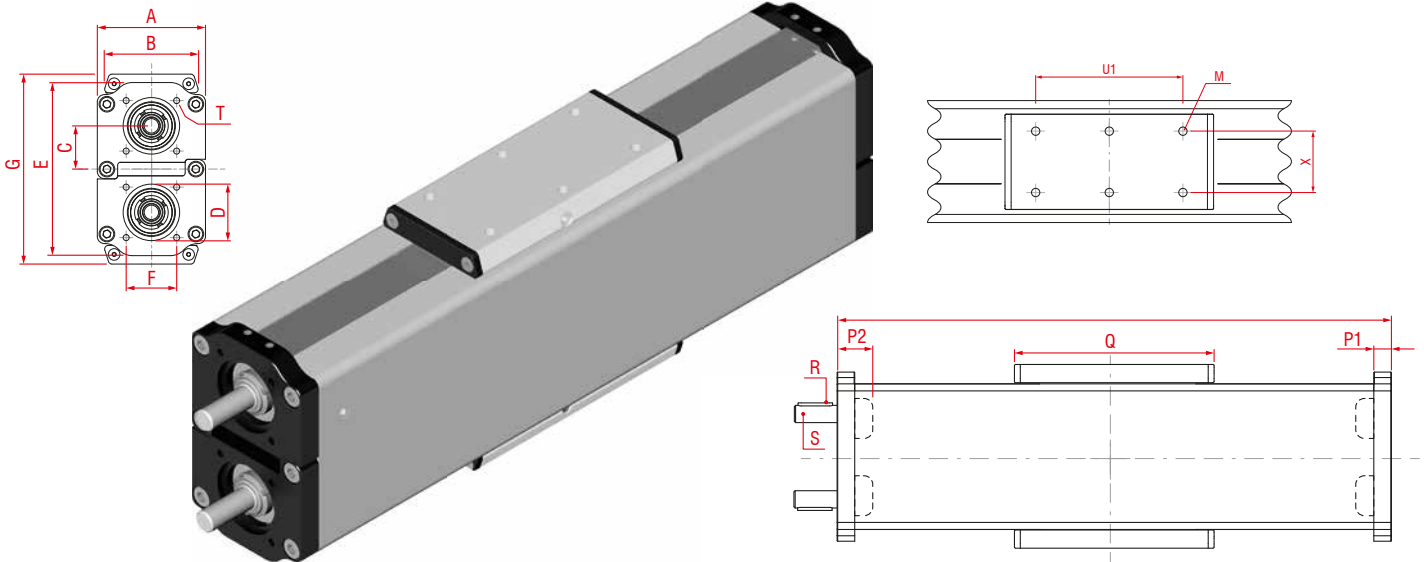

\*For slide nuts refer to chapter 2.2 page 2

Increasing the carriage length will increase the basic length by the same amount.

Size	Basic length L	A	B	C	D -0,05	E	F □	G	M for	P1	P2	Q	Shaft		T for	U1	X	Basic weight	Weight per 100 mm
													R key	S Ø h6 x length					
<b>GDGKex 90</b>	242	90	78	36	47	144	42	158	M8	15	36	170	5x5x28	14x35	M6	120	50	7,8 kg	1,5 kg

**K Spindle:**  
(K) Ballscrew

**1 Selection of screw:**  
(1) right hand (Standard) (2) left hand (by inquiry)

**0 Choice of guide body profile:**  
(0) Standard (1) corrosion-protected screws

**0 Choice of carriages:**

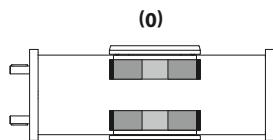

**0 Drive version:**  
(0) right (locating bearing side)  
(1) left (non-locating bearing side) (2) shaft on both sides

**0 Selection of screw:**  
(0) Kg 25x10

**0 Ballscrew pitch accuracy:**  
(0) 0,05 mm / 300 mm

**0 End play of ball nut:**  
(0) 0,04 mm

**Safety-related limits:**

- max. input speed 1500 min<sup>-1</sup>
- min. input speed 20 min<sup>-1</sup>
- nom. input torque 4 Nm
- max. starting torque 12.5 Nm
- max. static lifting power 1000 N
- max. dynamic lifting power 1500 N
- Operating modes S1
  - up to 120 full strokes per hour, evenly distributed
- stroke length 250 mm ..1500 mm
- Velocity 0.005 ms<sup>-1</sup> .. 0.5 ms<sup>-1</sup>
- ambient temperature range -20 °C < Ta < 60 °C

**Safety-related notes regarding lubrication:**

In potentially explosive atmospheres, you may only use lubrication systems that comply with the applicable regulations and are authorised by Bahr. The maintenance intervals for the lubricators have to be observed (e. g. operating and mounting instructions for perma FLEX, if these are used).

Note that the system is not lubricated during the lubricator activation time! Before starting operation, ensure that the lubrication system is working flawlessly and check the activation documentation.

The lubrication line of the lubricator must not exceed 0.5 m in length. The lubricator and the lubrication line are pressurized. When performing maintenance work ensure that no air bubbles can form within the lubrication system, that the lubrication lines are not kinked and that the lubricator is not exposed to mechanical loads.

Preset dispensing time	Activation time
1 month	1 day
3 months	5 days
6 months	14 days
12 months	28 days

**GDG K EX 90 1 0 0 0 0 0 0 1500** Basic length + stroke = total length  
Pos. 1 2 3 4 5 6 7

Sample ordering code:  
GDGKex 90, ballscrew right hand, carriage version 0, drive version 0, spindle Kg 25x10, 1258 mm stroke