

Linear system **DLZPVI 120, 160, 200**

BELT DRIVE

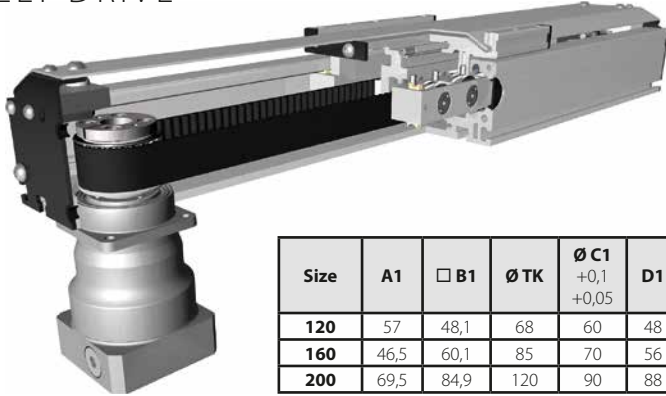

Size	A1	B1	TK	C1	D1	E1	F1
120	57	48,1	68	60 +0,1 +0,05	48	16	M5
160	46,5	60,1	85	70	56	22	M6
200	69,5	84,9	120	90	88	32	M8

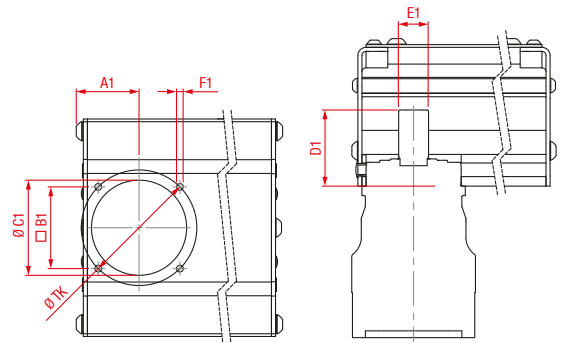

Function:

This unit consists of a rectangular aluminium profile with 2 integrated roller guides. The carriage is moved by a belt drive. On the drive side the pulley is beared on the shaft of a planetary gear. Belt tension can be readjusted by a simple screw adjustment at the opposite side of the drive. A special curved aluminium sheet is covering the carriage side. There is only a small gap between carriage and aluminium sheet. Because of its special design it is possible to drive the carriage over the pulley areas. This fact is making the unit very compact. The cover profile can be adjusted according to the mounting position.

Fitting position:

As required, max. length DLZPVI 120 / 1600mm, DLZPVI 160 / 1800mm, DLZPVI 200 / 2000mm

Carriage mounting:

By tapped holes.

Unit mounting:

T-slots

Belt type:

HTD with steel reinforcement, no backlash when changing direction, repeatability $\pm 0,1$ mm.

Carriage support:

In the standard version, the carriage runs on 4 runner blocks which can be serviced at a central servicing position. For longer carriages the number of runner blocks can be increased.

8.1

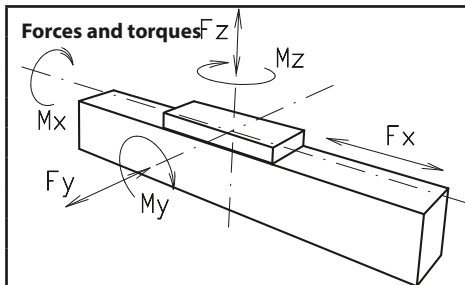

Size	120		160		200	
	static	dynamic	static	dynamic	static	dynamic
Forces/Torques						
F_x (N)	894	800	1900	1800	4000	3800
F_y (N)	1100	900	3000	2000	4400	3100
F_z (N)	1250	1000	3500	2800	4900	4400
M_x (Nm)	150	125	400	320	600	510
M_y (Nm)	140	120	360	300	560	480
M_z (Nm)	100	90	180	150	310	275
All forces and torques related to the following:						
existing values $\frac{F_y}{F_{y_{dyn}}} + \frac{F_z}{F_{z_{dyn}}} + \frac{M_x}{M_{x_{dyn}}} + \frac{M_y}{M_{y_{dyn}}} + \frac{M_z}{M_{z_{dyn}}} \leq 1$						
table values $\frac{F_y}{F_{y_{dyn}}} + \frac{F_z}{F_{z_{dyn}}} + \frac{M_x}{M_{x_{dyn}}} + \frac{M_y}{M_{y_{dyn}}} + \frac{M_z}{M_{z_{dyn}}} \leq 1$						
No-load torque						
Nm	1,2		1,5		1,8	
Speed						
(m/s) max	4		6		8	
Tensile force						
permanent (N)	900		1900		4000	
0,2 s (N)	1000		2090		4300	
Geometrical moments of inertia of aluminium profile						
I_x mm ⁴	6,6 x 10 ⁵		22,2 x 10 ⁵		57,2 x 10 ⁵	
I_y mm ⁴	38,6 x 10 ⁵		122,0 x 10 ⁵		310 x 10 ⁵	
Elastic modulus N/mm ²	70000		70000		70000	

For life-time calculation of rollers use our homepage.

Driving torque:

$$M_o = \frac{F \cdot P \cdot S_i}{2000 \cdot \pi} + M_n$$

$$P_o = \frac{M_o \cdot n}{9550}$$

F = force (N)
 P = pulley action perimeter (mm)
 S_i = safety factor 1,2 ... 2
 M_n = no-load torque (Nm)
 n = rpm pulley (min⁻¹)
 M_o = driving torque (Nm)
 P_o = motor power (KW)

Deflection:

$$f = \frac{F \cdot L^3}{E \cdot I \cdot 192}$$

f = deflection (mm)
 F = load (N)
 L = free length (mm)
 E = elastic modulus 70000 (N/mm²)
 I = second moment of area (mm⁴)

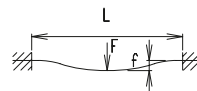

Linear system **DLZPVI 120, 160, 200**

Dimensions (mm)

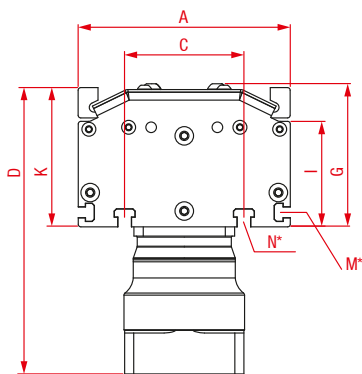

Optionally available with angular planetary gearbox

Increasing the carriage length will increase the basic length by the same amount.

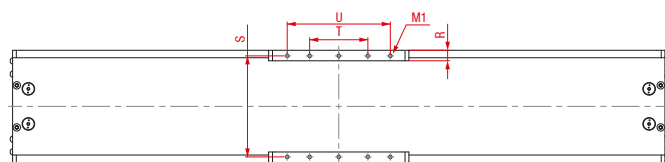
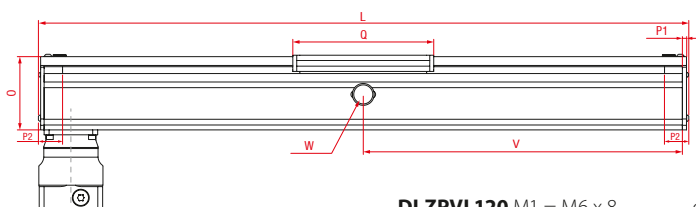

DLZPVI 120 M1 = M6 x 8 only 8 threaded holes in the carriage

$V = Q + 100$

DLZPVI 160 M1 = M8 x 12 **DLZPVI 200** M1 = M10 x 12

$W =$ servicing position

*slide nuts

Size	Basic length L	A	C	D	G	I	K	M for	N for	O	P1	P2	Q	R	S	T	U	Basic weight without gearbox	Weight per 100 mm
DLZPVI 120	225	120	78	169	82,5	60	79	M5	M6	78	6	35	152	11,5	106	40	120	3,74 kg	0,65 kg
DLZPVI 160	285	160	90	217,5	108,5	80	106	M6	M8	104	8,25	43,5	196	15	144	80	160	10,42 kg	1,26 kg
DLZPVI 200	350	200	140	251	132,5	100	129	M8	M10	128	10	45,5	256	17	180	100	200	17,44 kg	2,18 kg

8.1

0 Choice of guide body profile: Stainless versions upon request.

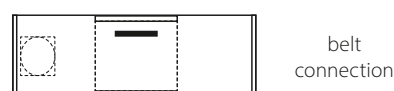
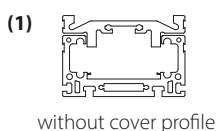
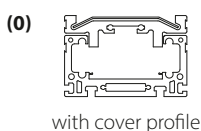

0 Choice of carriages:

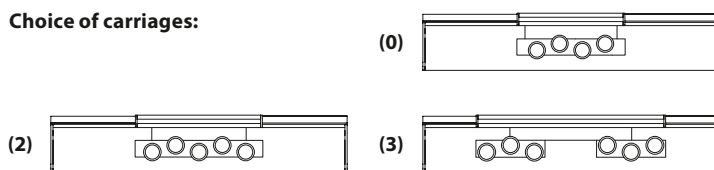

Size	Version 2		Version 3	
	Q	L	Q	L
120	192	265	232	305
160	246	335	296	385
200	320	420	400	500

0 Drive version:

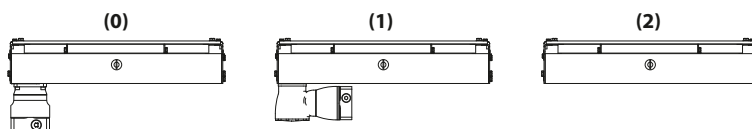

(0) planetary gearbox
 (1) angular planetary gearbox
 (2) without gearbox

Belt table:

Code-No.	Size	Belt	mm/rev.	Number of teeth
0 4	120	5M25	130	26
0 7	160	8M30	176	22
0 9	200	8M50	224	28

Gearbox variants:

Gearbox	DLZPVI 120	DLZPVI 160	DLZPVI 200
Neugart	(0) PLN 70 (1) WPLN 70	PLN 90 WPLN 90	PLN 115 WPLN 115
SEW	(0) PSKC 221	PSKC 321	PSKC 521
Wittenstein	(0) SP+060 (1) SK+060	SP+075 SK+075	SP+100 SK+100

DLZPVI 160 1 0 0 0 0 7 1 1500 — Basic length + stroke = total length

Pos. 1 2 3 4 5 6 7

Sample ordering code:

DLZPVI 160 with cover profile, standard carriage, with planetary gearbox, 1202 mm stroke.

