

Ezi-STEP[®] II

Micro Stepping System

- CiA402 Drive Profile Support
- Microstepping
- Software Damping
- High Torque

EtherCAT[®]



CE

FASTECH

Fast, Accurate, Smooth Motion



Fast, Accurate, Smooth Motion

Ezi-STEP[®] II EtherCAT[®]
Micro Stepping System



2 High Torque

(Motor Voltage Increasing and Motor Current Setting)

Ezi-STEP II boosts the voltage supplied to the motor by internal DC-DC Converter. The torque at the high-speed is increased. In addition, it is possible to set the Run Current up to 150%, whereby the torque at low-speed is increased.

Torque can be improved by about 30% over the entire speed range.

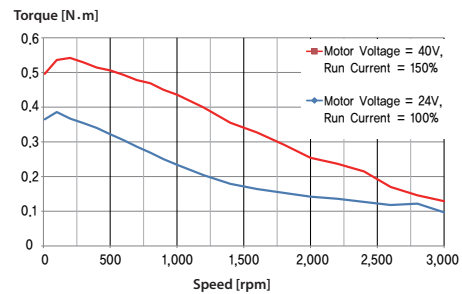

※ The torque at high speed is improved about 30%

Measured Condition : Drive = Ezi-STEP II-EC-42L
 Motor Voltage = DC40V
 Input Voltage = DC24V

1 EtherCAT Based Motion Control

Ezi-STEP II EtherCAT is stepping motor control system using EtherCAT, high speed ethernet (100Mbps Full-Duplex) based fieldbus. Ezi-STEP II EtherCAT is EtherCAT slave module which supports CAN application layer over EtherCAT (CoE). It employs CiA 402 Drive Profile and supports Profile Position Mode, Homing Mode, Cyclic Synchronous Position Mode.

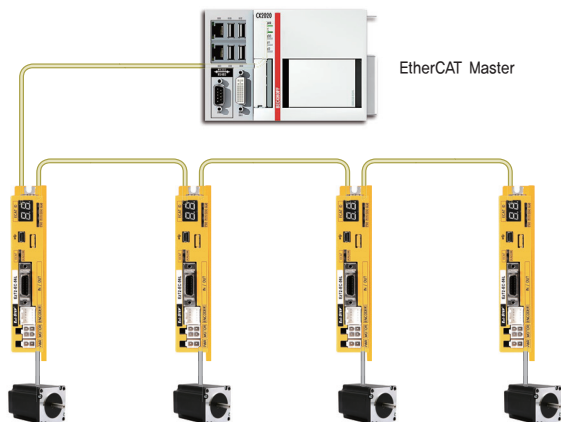

3 Microstep and Filtering

The high-performance MCU operates at step resolutions of 1.8° up to maximum 0.0072° (1/250 steps) and Ezi-STEP II adjusts PWM control signal in every 50μsec, which makes it possible for more precise current control, resulting in high-precision Microstep operation. In addition, Ezi-STEP II applies filtering control to enable smooth operation even at very low-speed.

4 Software Damping

Motor vibration is created by magnetic flux variations of the motor, lower current from the drive due to back-emf from the motor at high speeds and lowering of phase voltages from the drive.

Ezi-STEP II drive detects these problems and the MCU adjusts the phase of the current according to the pole position of the motor, drastically suppressing vibration. This allows the smooth operation of the motor at high-speeds.

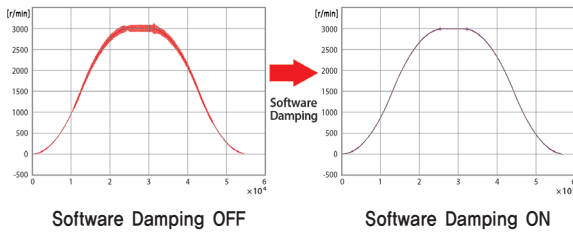

※ This is real measured speed that using 100,000 P/R encoder.

5 Improved high-speed operation performance

Depending on the speed of a stepping motor, Ezi-STEP II automatically increases the supply voltage and prevents the torque lowering due to the low operating voltage to the motor caused by back-emf voltage, this enables high-speed operation. Additionally, the software damping algorithm minimizes the vibration and prevents the loss-of-synchronization at high-speed.

Applicable model : Ezi-STEP II-EC-42 Series
Ezi-STEP II-EC-56 Series
Ezi-STEP II-EC-60 Series

Ezi-STEP II EtherCAT Part Numbering

Ezi-STEP II-EC-42S-BK

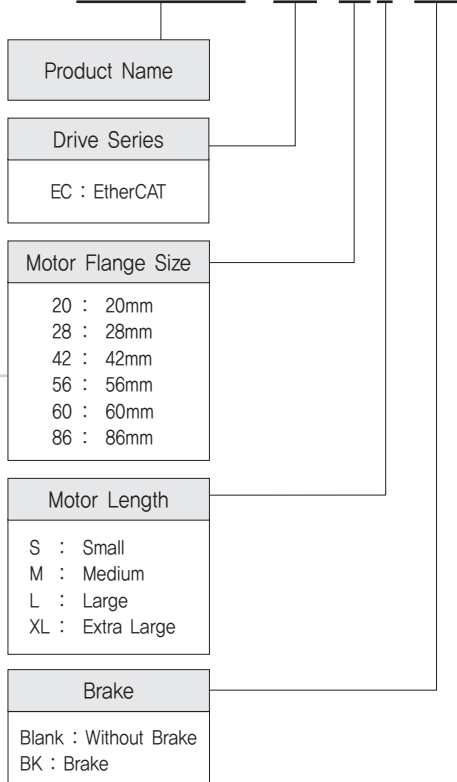

Standard Combination

Unit Part Number	Motor Model Number	Drive Model Number
Ezi-STEP II-EC-20M	BM-20M	EzT2-EC-20M
Ezi-STEP II-EC-20L	BM-20L	EzT2-EC-20L
Ezi-STEP II-EC-28S	BM-28S	EzT2-EC-28S
Ezi-STEP II-EC-28M	BM-28M	EzT2-EC-28M
Ezi-STEP II-EC-28L	BM-28L	EzT2-EC-28L
Ezi-STEP II-EC-42S	BM-42S	EzT2-EC-42S
Ezi-STEP II-EC-42M	BM-42M	EzT2-EC-42M
Ezi-STEP II-EC-42L	BM-42L	EzT2-EC-42L
Ezi-STEP II-EC-42XL	BM-42XL	EzT2-EC-42XL
Ezi-STEP II-EC-56S	BM-56S	EzT2-EC-56S
Ezi-STEP II-EC-56M	BM-56M	EzT2-EC-56M
Ezi-STEP II-EC-56L	BM-56L	EzT2-EC-56L
Ezi-STEP II-EC-60S	BM-60S	EzT2-EC-60S
Ezi-STEP II-EC-60M	BM-60M	EzT2-EC-60M
Ezi-STEP II-EC-60L	BM-60L	EzT2-EC-60L
Ezi-STEP II-EC-86M	BM-86M	EzT2-EC-86M
Ezi-STEP II-EC-86L	BM-86L	EzT2-EC-86L
Ezi-STEP II-EC-86XL	BM-86XL	EzT2-EC-86XL

Combination with Brake

Unit Part Number	Motor Model Number	Drive Model Number
Ezi-STEP II-EC-42S-BK	BM-42S-BK	EzT2-EC-42S
Ezi-STEP II-EC-42M-BK	BM-42M-BK	EzT2-EC-42M
Ezi-STEP II-EC-42L-BK	BM-42L-BK	EzT2-EC-42L
Ezi-STEP II-EC-42XL-BK	BM-42XL-BK	EzT2-EC-42XL
Ezi-STEP II-EC-56S-BK	BM-56S-BK	EzT2-EC-56S
Ezi-STEP II-EC-56M-BK	BM-56M-BK	EzT2-EC-56M
Ezi-STEP II-EC-56L-BK	BM-56L-BK	EzT2-EC-56L
Ezi-STEP II-EC-60S-BK	BM-60S-BK	EzT2-EC-60S
Ezi-STEP II-EC-60M-BK	BM-60M-BK	EzT2-EC-60M
Ezi-STEP II-EC-60L-BK	BM-60L-BK	EzT2-EC-60L
Ezi-STEP II-EC-86M-BK	BM-86M-BK	EzT2-EC-86M
Ezi-STEP II-EC-86L-BK	BM-86L-BK	EzT2-EC-86L
Ezi-STEP II-EC-86XL-BK	BM-86XL-BK	EzT2-EC-86XL

● Specifications of Drive

Motor Model	BM-20 series	BM-28 series	BM-42 series	BM-56 series	BM-60 series	BM-86 series
Drive Model	EzT2-EC-20 series	EzT2-EC-28 series	EzT2-EC-42 series	EzT2-EC-56 series	EzT2-EC-60 series	EzT2-EC-86 series
Input Voltage	DC24V±10%					DC40~70V
Control Method	Bipolar PWM drive with 32bit MCU					
Current Consumption	Max. 500mA (Except motor current)					
Operating Condition	Ambient Temperature	· In Use: 0~50°C · In Storage: -20~70°C				
	Humidity	· In Use: 35~85%RH (Non-Condensing) · In Storage: 10~90%RH (Non-Condensing)				
	Vib. Resist.	0.5g				
Function	Rotation Speed	0~3,000r/min				
	Resolution	Configurable Resolution [P/R] 500 1,000 1,600 2,000 3,200 3,600 4,000 5,000 6,400 8,000 10,000 20,000 25,000 36,000 40,000 50,000 (Selectable by parameter)				
	Error Type	Over Current Error, Over Speed Error, Over Temperature Error, Over Regenerated Voltage Error, Motor Connect Error, ROM Error				
	LED Display	Power status, Alarm status, Run status, STEP On status				
EtherCAT	Supported Protocol	CoE (CiA 402 Drive Profile), FoE (Firmware Download)				
	Supported Mode	Profile Position Mode, Homing Mode, Cyclic Synchronous Position Mode				
	Synchronization	Free Run, SM Event, DC SYNC Event				
I/O Signal	Input Signals	3 dedicated inputs (LIMIT+, LIMIT-, ORIGIN), 7 programmable inputs (Photocoupler Input)				
	Output Signals	6 programmable outputs (Photocoupler Output), 1 Brake output				

● Dimensions of Drive [mm]

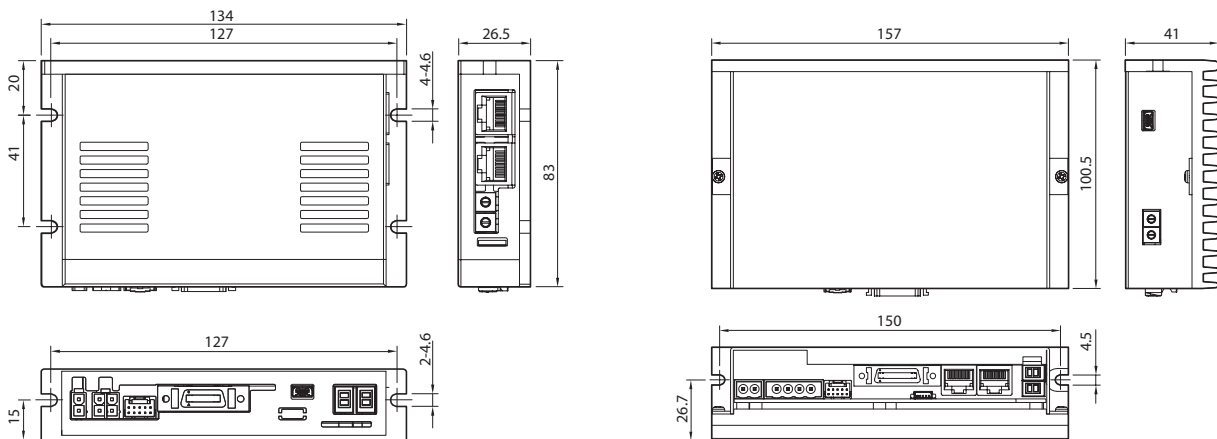

※ 86mm motor drive (EzT2-EC-86 series)

● Specifications of Motor

MODEL			BM-20 series		BM-28 series			BM-42 series				
			UNIT	20M	20L	28S	28M	28L	42S	42M	42L	42XL
DRIVE METHOD			-	Bipolar								
NUMBER OF PHASES			-	2 Phase								
CURRENT per PHASE			A/Phase	0,5	0,5	0,95	0,95	0,95	1,2	1,2	1,2	1,2
MAXIMUM HOLDING TORQUE			N·m	0,016	0,025	0,069	0,098	0,118	0,32	0,44	0,5	0,65
ROTOR INERTIA			g·cm ²	2,5	3,3	9,0	13	18	35	54	77	114
WEIGHTS			kg	0,053	0,078	0,115	0,174	0,202	0,238	0,303	0,374	0,508
LENGTH(L)			mm	28	38	32	45	50	34	40	48	60
PERMISSIBLE RADIAL LOAD	DIS-TANCE FROM END OF SHAFT	3mm	N	18	18	30	30	30	22	22	22	22
		8mm		30	30	38	38	38	26	26	26	26
		13mm		-	-	53	53	53	33	33	33	33
		18mm		-	-	-	-	-	46	46	46	46
PERMISSIBLE AXIAL LOAD			N	Lower than Unit's Weight								
INSULATION RESISTANCE			MΩ	Min, 100(When measured with a DC500V insulation resistance meter)								
INSULATION CLASS			-	CLASS B(130°C)								
OPERATING TEMPERATURE			°C	0 ~ 55								

MODEL			BM-56 series			BM-60 series			BM-86 series			
			UNIT	56S	56M	56L	60S	60M	60L	86M	86L	86XL
DRIVE METHOD			-	Bipolar								
NUMBER OF PHASES			-	2 Phase								
CURRENT per PHASE			A/Phase	3,0	3,0	3,0	4,0	4,0	4,0	6,0	6,0	6,0
MAXIMUM HOLDING TORQUE			N·m	0,64	1,0	1,5	0,88	1,28	2,4	4,5	8,5	12
ROTOR INERTIA			g·cm ²	180	280	520	240	490	690	1800	3600	5400
WEIGHTS			kg	0,548	0,726	1,159	0,616	0,793	1,349	2,275	3,808	5,330
LENGTH(L)			mm	46	55	80	47	56	85	78	117	155
PERMISSIBLE RADIAL LOAD	DIS-TANCE FROM END OF SHAFT	3mm	N	52	52	52	70	70	70	270	270	270
		8mm		65	65	65	87	87	87	300	300	300
		13mm		85	85	85	114	114	114	350	350	350
		18mm		123	123	123	165	165	165	400	400	400
PERMISSIBLE AXIAL LOAD			N	Lower than Unit's Weight								
INSULATION RESISTANCE			MΩ	Min, 100(When measured with a DC500V insulation resistance meter)								
INSULATION CLASS			-	CLASS B(130°C)								
OPERATING TEMPERATURE			°C	0 ~ 55								

Torque Characteristics of Motor

Ezi-STEP II-EC-20 series

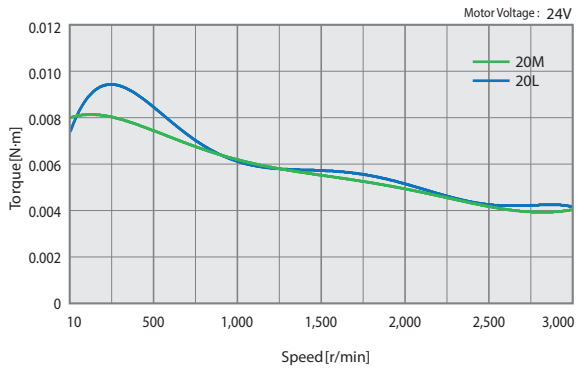

Ezi-STEP II-EC-28 series

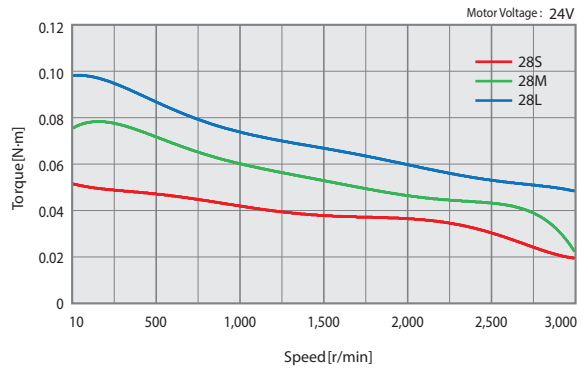

Ezi-STEP II-EC-42 series

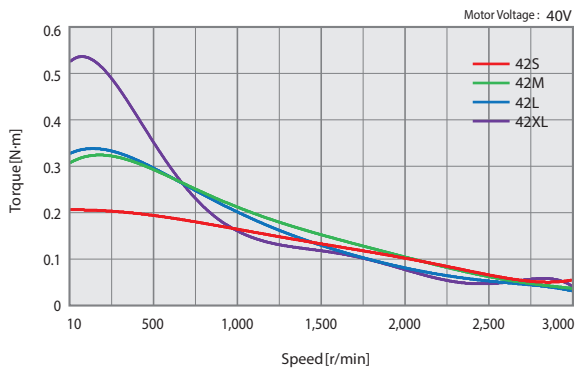

Ezi-STEP II-EC-56 series

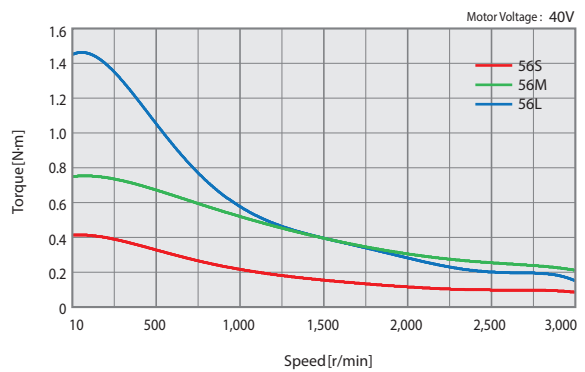

Ezi-STEP II-EC-60 series

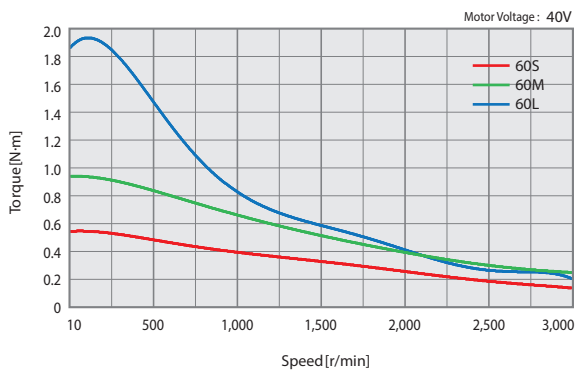

Ezi-STEP II-EC-86 series

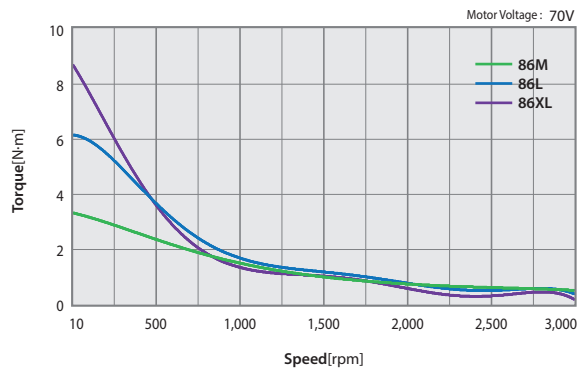

● Dimensions of Motor [mm]

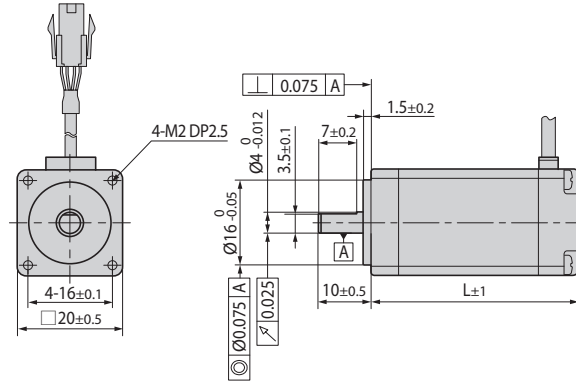

20mm

Model name	Length(L)
BM-20M	28
BM-20L	38

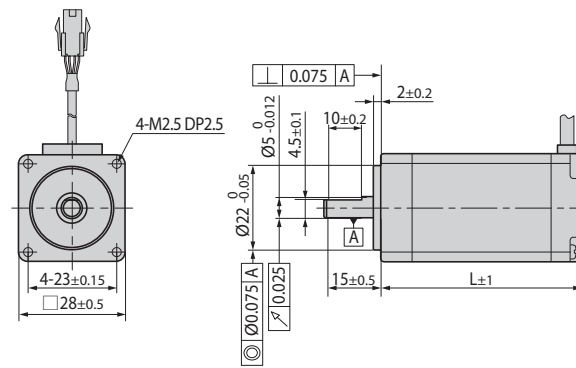

28mm

Model name	Length(L)
BM-28S	32
BM-28M	45
BM-28L	50

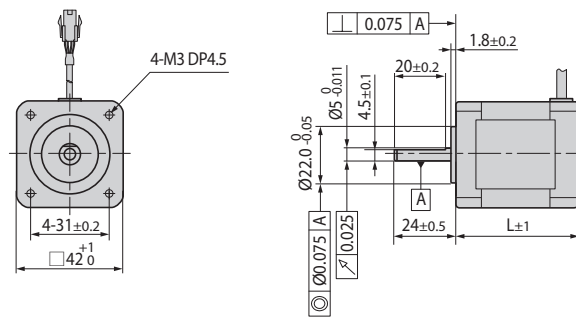

42mm

Model name	Length(L)
BM-42S	34
BM-42M	40
BM-42L	48
BM-42XL	60

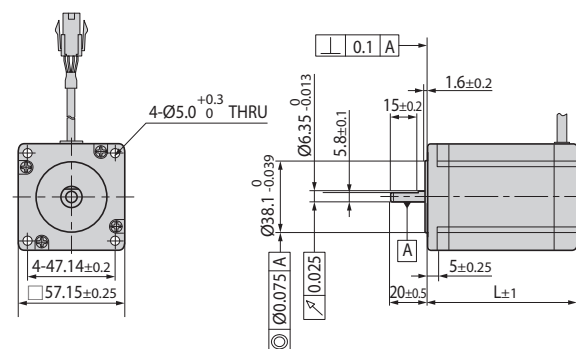

56mm

Model name	Length(L)
BM-56S	46
BM-56M	55
BM-56L	80

● Dimensions of Motor [mm]

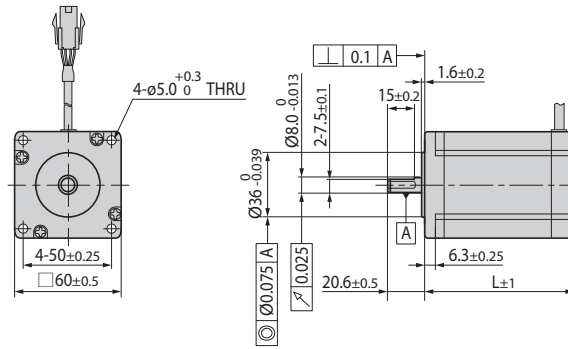

60mm

Model name	Length(L)
BM-60S	47
BM-60M	56
BM-60L	85

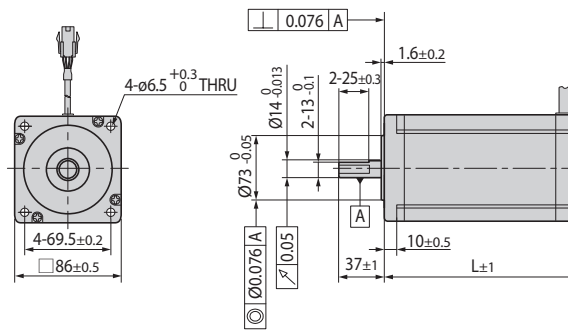

86mm

Model name	Length(L)
BM-86M	78
BM-86L	117
BM-86XL	155

● Specifications of Motor with Brake

Unit Part Number	Motor Model Number	Electromagnetic Brake					Motor Unit Weight [kg]	Permissible Radial Load [N]				Permissible Axial Load [N]
		Type	Voltage Input [V]	Rated Current [A]	Power Consumption [W]	Static Friction Torque [N·m]		Distance from End of Shaft [mm]				
								3	8	13	18	
Ezi-STEP II-EC-42S-BK	BM-42S-BK	Non-excitation run Type	DC24V ±10%	0,2	5	0,2	0,500	22	26	33	46	Must be Lower than Motor Unit Weight
Ezi-STEP II-EC-42M-BK	BM-42M-BK						0,560					
Ezi-STEP II-EC-42L-BK	BM-42L-BK						0,630					
Ezi-STEP II-EC-42XL-BK	BM-42XL-BK						0,770					
Ezi-STEP II-EC-56S-BK	BM-56S-BK			0,27	6,6	0,7	0,970	52	65	85	123	
Ezi-STEP II-EC-56M-BK	BM-56M-BK						1,150					
Ezi-STEP II-EC-56L-BK	BM-56L-BK						1,580					
Ezi-STEP II-EC-60S-BK	BM-60S-BK						1,060					
Ezi-STEP II-EC-60M-BK	BM-60M-BK			1,230	70	87	114	165				
Ezi-STEP II-EC-60L-BK	BM-60L-BK			1,790								
Ezi-STEP II-EC-86M-BK	BM-86M-BK			3,580								
Ezi-STEP II-EC-86L-BK	BM-86L-BK			5,110								
Ezi-STEP II-EC-86XL-BK	BM-86XL-BK			6,630	270	300	350	400				

- * Electronic Brake cannot be used for braking. Position hold purpose only when power OFF.
- * The weight means Motor Unit Weight including Motor and Electronic Brake.
- * Motor Model Number is combined model name of Motor and Brake.
- * Motor specification and torque characteristic are same as Standard Motor.
- * An external power supply (DC24V) is not required when installing the Electric Brake on the 86mm motor drive.

* Brake Operation Timing Chart

Ezi-STEP II EtherCAT controls Brake by Drive automatically. Please refer to below Timing Chart when Brake is controlled by the upper controller other than using Ezi-STEP II EtherCAT Brake control. Otherwise, Drive might malfunction and loads might fall down. Also, please do not operate Brake during motor operation to prevent damage.

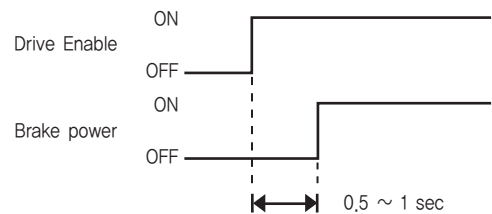

● Dimensions of Motor with Brake [mm]

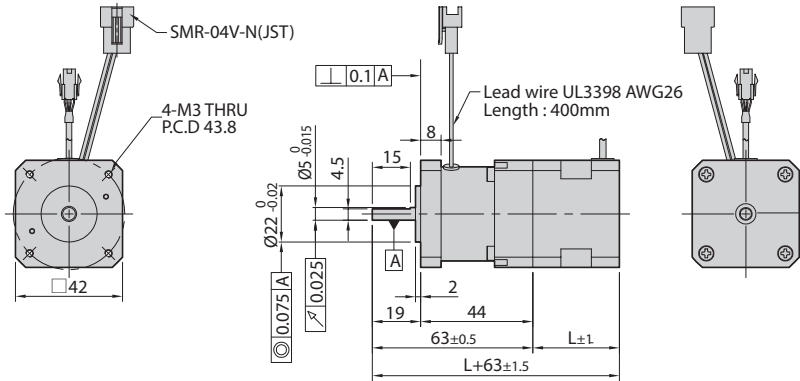

42mm

Model name	Length(L)
BM-42S	34
BM-42M	40
BM-42L	48
BM-42XL	60

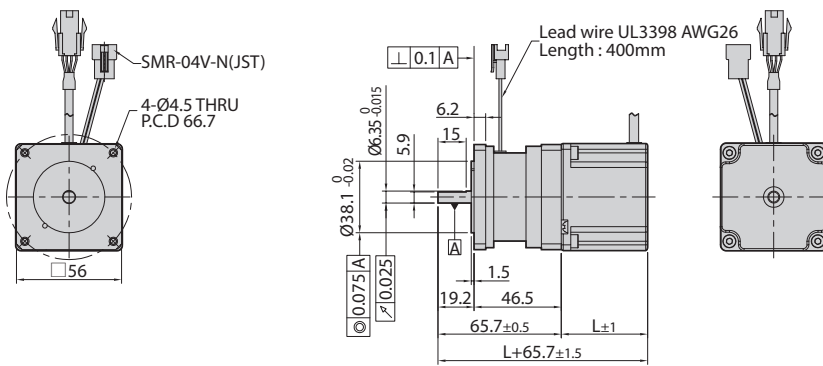

56mm

Model name	Length(L)
BM-56S	46
BM-56M	55
BM-56L	80

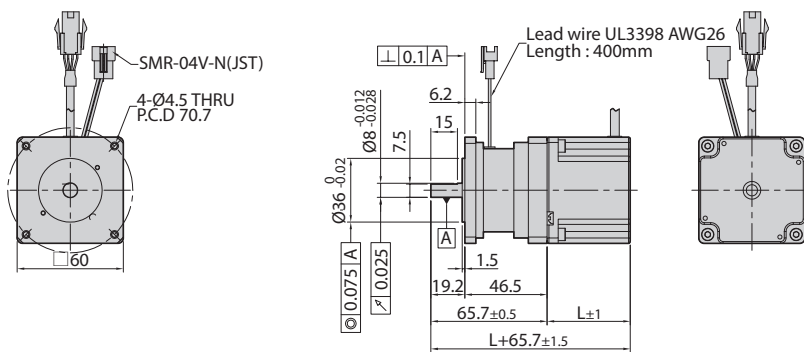

60mm

Model name	Length(L)
BM-60S	47
BM-60M	56
BM-60L	85

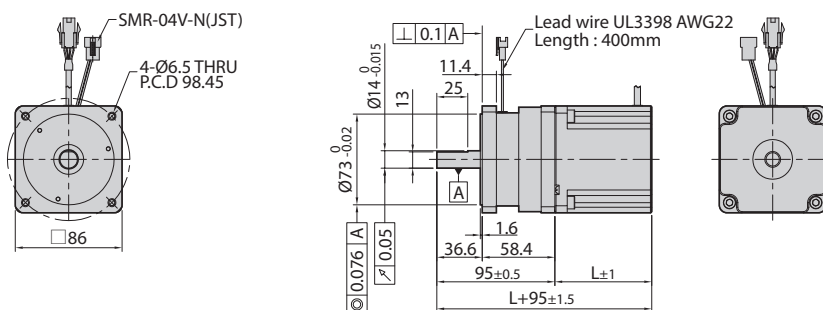

86mm

Model name	Length(L)
BM-86M	78
BM-86L	117
BM-86XL	155

● Settings and Operation

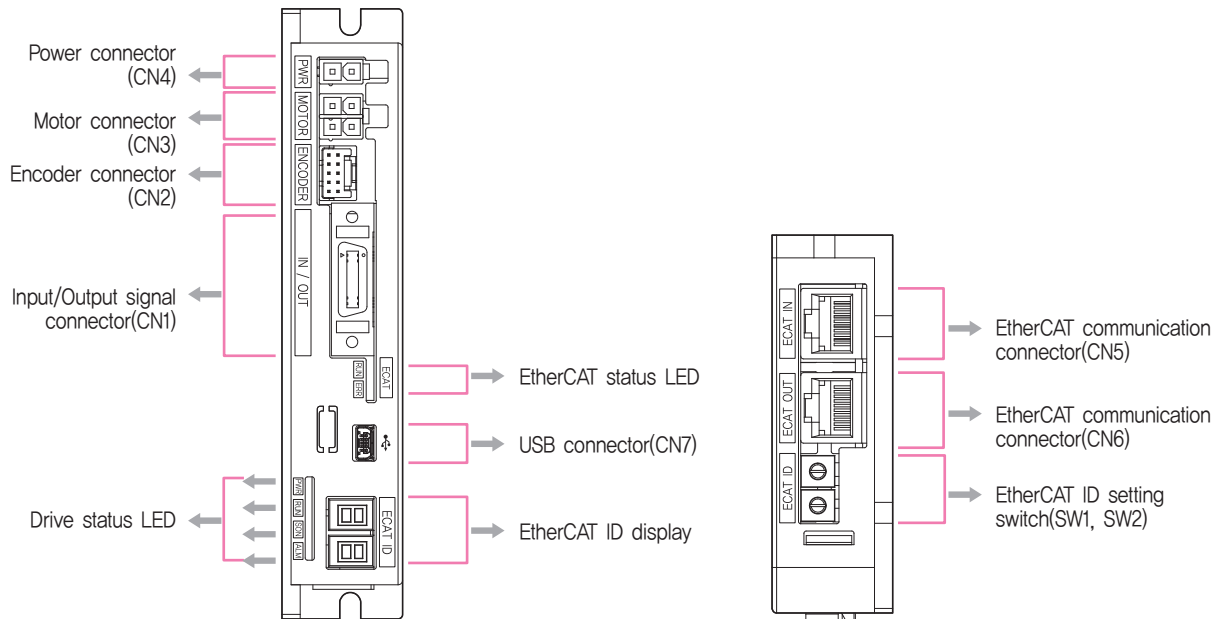

◆ 86mm Motor Drive (EzT2-EC-86 series)

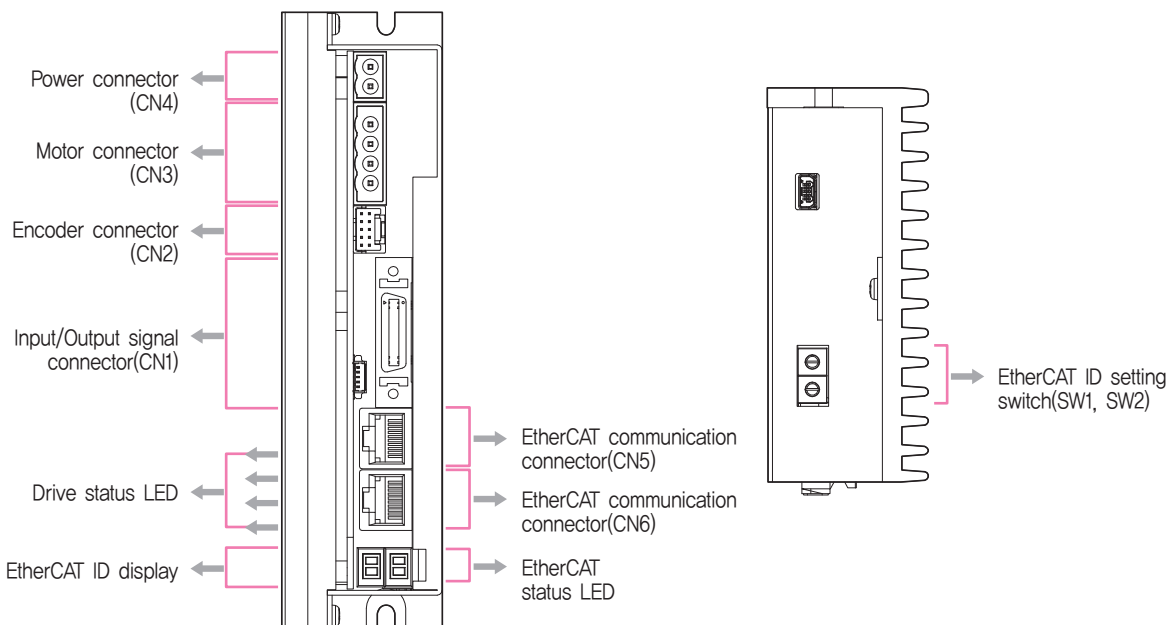

1. EtherCAT ID Display and Setting Switch (SW1, SW2)

Use two rotary switches to set EtherCAT ID (ECAT Device ID). Set ones digit (x1) of EtherCAT ID on the right rotary switch (SW1), and set tens digit (x10) of EtherCAT ID on the left rotary switch (SW2).

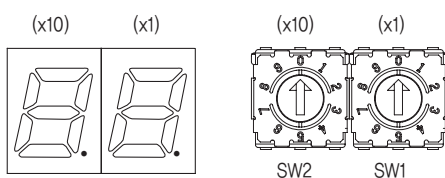

2. EtherCAT Status LED

LED indicates communication status of EtherCAT. Link/Activity LED exists on each port of EtherCAT.

Name	Color	Status	Description
RUN	Green	OFF	State INIT or Power OFF
		Blinking	State PRE-OPERATIONAL
		Single Flash	State SAFE-OPERATIONAL
		ON	State OPERATIONAL
		Flickering	State BOOTSTRAP

Name	Color	Status	Description
ERR	Red	OFF	No Error or Power OFF
		Blinking	Invalid Configuration
		Single Flash	Local Error
		Double Flash	Watchdog Time Out

Name	Color	Status	Description
Link/ Activity	Green	OFF	Link not Established
		ON	Link Established
		Flickering	Link Established and in Operation

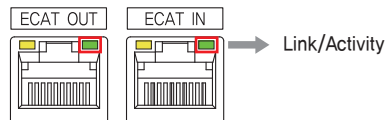
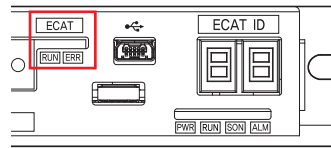

3. Drive Status LED

LED informs operation status of the drive.

Indication	Color	Function	Explanation
PWR	Green	Power Input Indication	LED is turned ON when power is applied
RUN	Yellow	Motor running indication	LED is turned ON while motor is rotating
SON	Orange	STEP ON / OFF Indication	STEP ON: Lights ON, STEP OFF: Lights OFF
ALM	Red	Alarm Indication	LED blinks when an error occurs.

◆ List of error types by the the number of LED blinking

No.	Error Code ^{*3}	Error Type	Causes
1	E-001	Over Current Error	The current through power devices in drive exceeds the limit, ^{*1}
2	E-002	Over Speed Error	The motor speed exceeds 3,000r/min
5	E-005	Over Temperature Error	Internal temperature of the drive exceeds 85°C
6	E-006	Over Regenerative Voltage Error	Back-EMF is higher than limit value ^{*2}
7	E-007	Motor Connect Error	There is a problem with the connection between the drive and the motor
12	E-012	ROM Error	Error occurs in parameter storage device(ROM)

*1 : Limit value depends on motor model. (Refer to the Manual)

*2 : Voltage limit of Back-EMF depends on motor model. (Refer to the Manual)

*3 : When an alarm occurs, error code is displayed on the 7-segment LED display instead of EtherCAT ID.

※ Please refer to user Manual for the details of protection functions.

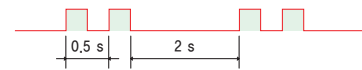

Alarm LED flash
(e.g., Over Speed Error)

4. Input/Output Signal Connector (CN1)

No.	Function	I/O
1	LIMIT+	Input
2	LIMIT-	Input
3	ORIGIN	Input
4	Digital In1	Input
5	Digital In2	Input
6	Digital In3	Input
7	Digital In4	Input
8	Digital In5	Input
9	Digital In6	Input
10	Digital In7	Input
11	Digital Out1	Output
12	Digital Out2	Output
13	Digital Out3	Output
14	Digital Out4	Output
15	Digital Out5	Output
16	Digital Out6	Output
17	BRAKE+	Output
18	BRAKE-	Output
19	EXT_GND	Input
20	EXT_DC24V	Input

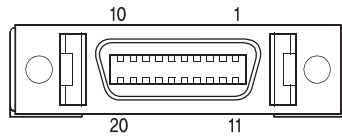

6. Motor Connector (CN3)

No.	Function	I/O
1	A Phase	Output
2	B Phase	Output
3	\bar{A} Phase	Output
4	\bar{B} Phase	Output



No.	Function	I/O
1	\bar{B} Phase	Output
2	B Phase	Output
3	\bar{A} Phase	Output
4	A Phase	Output

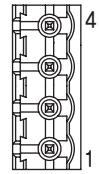

※ 86mm motor drive

7. Power Connector (CN4)

No.	Function	I/O
1	DC24V	Input
2	GND	Input



No.	Function	I/O
1	GND	Input
2	DC40~70V	Input



※ 86mm motor drive

5. Encoder Connector (CN2)

No.	Function	I/O
1	A+	Input
2	A-	Input
3	B+	Input
4	B-	Input
5	Z+	Input
6	Z-	Input
7	DC5V	Output
8	GND	Output
9	F_GND	----
10	F_GND	----

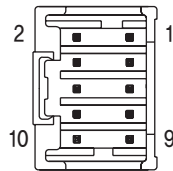

8. EtherCAT Communication Connector (CN5, CN6)

No.	Function	No.	Function
1	TD+	6	RD-
2	TD-	7	----
3	RD+	8	----
4	----	Connector hood F.GND	
5	----		

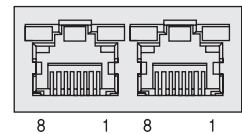

9. USB Connector (CN7)

No.	Function
1	V _{Bus}
2	D-
3	D+
4	---
5	GND

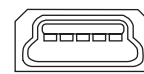

5 4 3 2 1

System Configuration

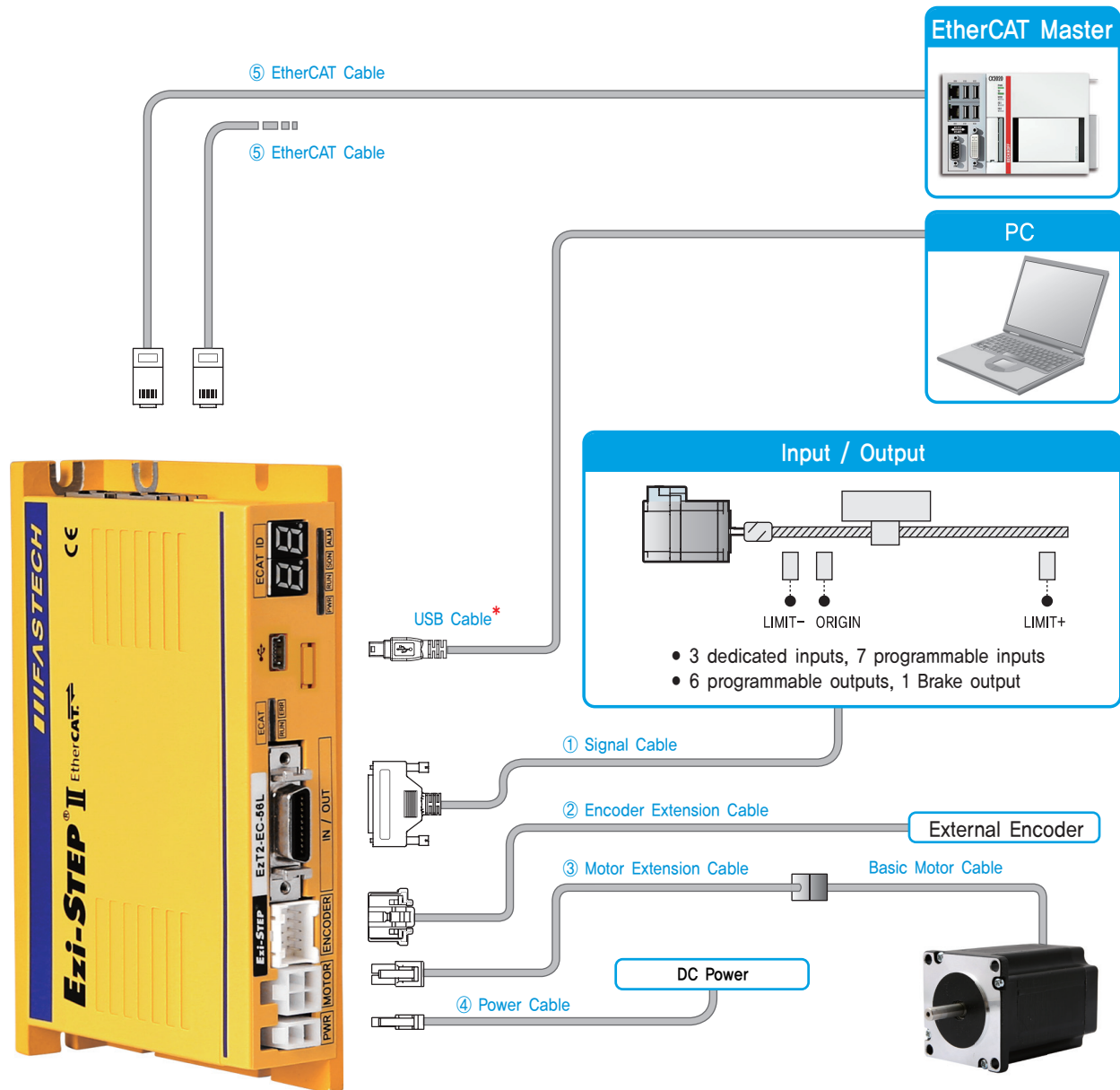

Cable Type	Max. Length	Remarks
① Signal Cable	20m	Options (Sold separately)
② Encoder Extension Cable	20m	
③ Motor Extension Cable	20m	
④ Power Cable	2m	
⑤ EtherCAT Cable	100m	
Basic Motor Cable	0.3m (Basic length)	Basic cables are attached to motors.
USB Cable	5m	* USB cables are not provided by FASTECH. We recommend using a standard USB cable (USB 2.0 Mini Type B).

1. Accessories

Connectors

These are connector specifications for drive cabling.

Purpose		Item	Part Number	Manufacturer
Power (CN4)		Housing	5557-02R	MOLEX
		Terminal	5556T	
Motor	Drive Side (CN3)	Housing	5557-04R	MOLEX
		Terminal	5556T	
	Motor Side	Housing	5557-04R	MOLEX
		Terminal	5556T	
Encoder	Drive Side (CN2)	Housing	51353-1000	MOLEX
		Terminal	56134-9000	
Signal (CN1)		Connector	10120-3000PE	3M
		Connector Cover	10320-52A0-008	

※ The connectors above are supplied with the product. If you are using other parts, please make sure they meet the specifications.

2. Options

① Signal Cable

These are the cables to connect Ezi-STEP II EtherCAT drive and other input/output devices.

Purpose	Part Number	Length [m]	Cable Type	Remarks
Drive - I/O Device Connection	CSVN-S-001F	1	Normal Cable	Maximum Length: 20m
	CSVN-S-002F	2		
	CSVN-S-003F	3		
	CSVN-S-005F	5		
	CSVN-S-001M	1	Robot Cable	
	CSVN-S-002M	2		
	CSVN-S-003M	3		
	CSVN-S-005M	5		

* If you need cables with length(in units of 1m) not listed on the table, please contact FASTECH for more information.

② Encoder Extension Cable

These are the cables to connect Ezi-STEP II EtherCAT drive and the encoder.

Purpose	Part Number	Length [m]	Cable Type	Remarks
Drive - External Encoder Connection	CTPR-E-001F	1	Normal Cable	Maximum Length: 20m
	CTPR-E-002F	2		
	CTPR-E-003F	3		
	CTPR-E-005F	5		
	CTPR-E-001M	1	Robot Cable	
	CTPR-E-002M	2		
	CTPR-E-003M	3		
	CTPR-E-005M	5		

* If you need cables with length(in units of 1m) not listed on the table, please contact FASTECH for more information.

③ Motor Extension Cable

These are the cables to connect Ezi-STEP II EtherCAT drive and the motor.

Purpose	Part Number	Length [m]	Cable Type	Remarks
Drive – Basic Motor Cable Connection	CSVO-M-001F	1	Normal Cable	Maximum Length: 20m
	CSVO-M-002F	2		
	CSVO-M-003F	3		
	CSVO-M-005F	5		
	CSVO-M-001M	1	Robot Cable	
	CSVO-M-002M	2		
	CSVO-M-003M	3		
	CSVO-M-005M	5		

* If you need cables with length(in units of 1m) not listed on the table, please contact FASTECH for more information.

④ Drive Power Cable

These are the cables to connect Ezi-STEP II EtherCAT drive and the power.

Purpose	Part Number	Length [m]	Cable Type	Remarks
Drive – Power Connection	CSVO-P-001F	1	Normal Cable	Maximum Length: 2m
	CSVO-P-002F	2		
	CSVO-P-001M	1	Robot Cable	
	CSVO-P-002M	2		

⑤ EtherCAT Cable

Purpose	Part Number	Length [m]	Remarks
EtherCAT Connection	CGNR-EC-001F	1	<ul style="list-style-type: none"> STP(Shielded Twisted Pair) Cable Category 5e or higher Maximum Length: 100m Normal Cable
	CGNR-EC-002F	2	
	CGNR-EC-003F	3	
	CGNR-EC-005F	5	

* If you need cables with length(in units of 1m) not listed on the table or robot cables, please contact FASTECH for more information.

[Option] TB-Plus Interface Board

This is an interface board to connect Ezi-STEP II EtherCAT drive and I/O signals more conveniently.

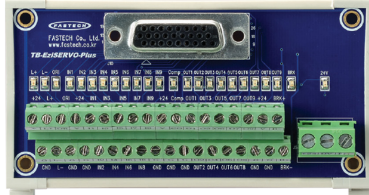
Purpose	Part Number	Product Image
Drive – I/O signal Connection Board	TB-Plus	

[Option] TB-Plus Interface Cable

These are the cables to connect Ezi-STEP II EtherCAT and TB-Plus interface board.

Purpose	Part Number	Length [m]	Cable Type	Remarks
Drive – Interface(TB-Plus) Connection	CIFN-S-001F	1	Normal Cable	Maximum Length: 20m
	CIFN-S-002F	2		
	CIFN-S-003F	3		
	CIFN-S-005F	5		
	CIFN-S-001M	1	Robot Cable	
	CIFN-S-002M	2		
	CIFN-S-003M	3		
	CIFN-S-005M	5		

* If you need cables with length not listed on the table, please contact FASTECH for more information.

● System Configuration [86mm Motor Drive]

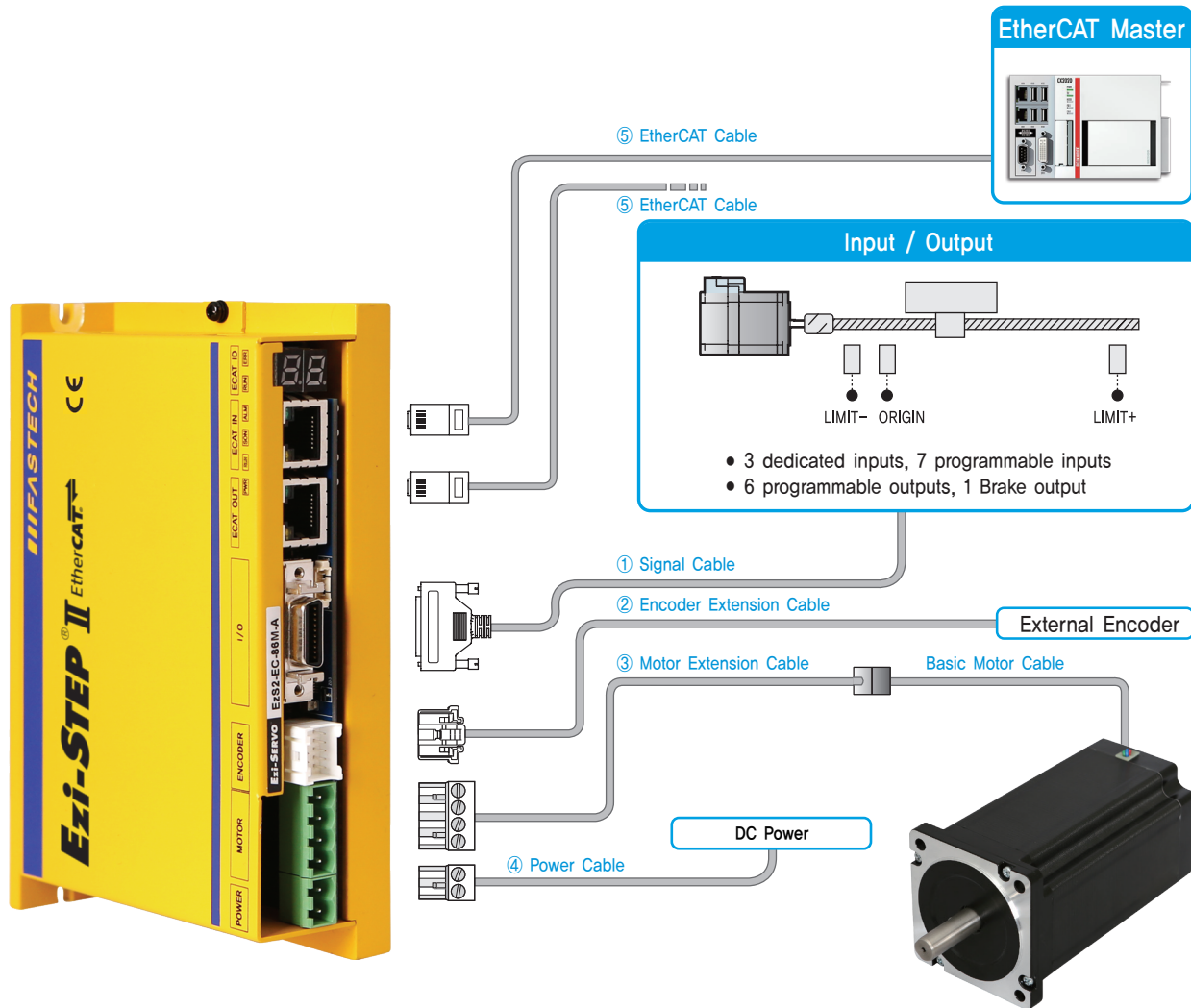

Cable Type	Max. Length	Remarks
① Signal Cable	20m	Options (Sold separately)
② Encoder Extension Cable	20m	
③ Motor Extension Cable	20m	
④ Power Cable	2m	
⑤ EtherCAT Cable	100m	
Basic Motor Cable	0,3m (Basic length)	Basic cables are attached to motors.

1. Accessories

Connectors

These are connector specifications for drive cabling.

Purpose		Item	Part Number	Manufacturer
Power (CN4)		Terminal Block	AK950-2	PTR
Motor	Drive Side (CN3)	Terminal Block	AK950-4	PTR
	Motor Side	Housing	3191-4R1	MOLEX
Terminal		1381T		
Encoder	Drive Side (CN2)	Housing	51353-1000	MOLEX
		Terminal	56134-9000	
Signal (CN1)	Connector		10120-3000PE	3M
	Connector Cover		10320-52A0-008	

※ The connectors above are supplied with the product. If you are using other parts, please make sure they meet the specifications.

2. Options

① Signal Cable

These are the cables to connect Ezi-STEP II EtherCAT drive and other input/output devices.

Purpose	Part Number	Length [m]	Cable Type	Remarks
Drive – I/O Device Connection	CSVN-S-001F	1	Normal Cable	Maximum Length: 20m
	CSVN-S-002F	2		
	CSVN-S-003F	3		
	CSVN-S-005F	5		
	CSVN-S-001M	1	Robot Cable	
	CSVN-S-002M	2		
	CSVN-S-003M	3		
	CSVN-S-005M	5		

* If you need cables with length(in units of 1m) not listed on the table, please contact FASTECH for more information.

② Encoder Extension Cable

These are the cables to connect Ezi-STEP II EtherCAT drive and the encoder.

Purpose	Part Number	Length [m]	Cable Type	Remarks
Drive – External Encoder Connection	CSVO-E-001F	1	Normal Cable	Maximum Length: 20m
	CSVO-E-002F	2		
	CSVO-E-003F	3		
	CSVO-E-005F	5		
	CSVO-E-001M	1	Robot Cable	
	CSVO-E-002M	2		
	CSVO-E-003M	3		
	CSVO-E-005M	5		

* If you need cables with length(in units of 1m) not listed on the table, please contact FASTECH for more information.

③ Motor Extension Cable

These are the cables to connect Ezi-STEP II EtherCAT drive and the motor.

Purpose	Part Number	Length [m]	Cable Type	Remarks
Drive – Basic Motor Cable Connection	CSVP-M-001F	1	Normal Cable	Maximum Length: 20m
	CSVP-M-002F	2		
	CSVP-M-003F	3		
	CSVP-M-005F	5		
	CSVP-M-001M	1	Robot Cable	
	CSVP-M-002M	2		
	CSVP-M-003M	3		
CSVP-M-005M	5			

* If you need cables with length(in units of 1m) not listed on the table, please contact FASTECH for more information.

④ Drive Power Cable

These are the cables to connect Ezi-STEP II EtherCAT drive and the power.

Purpose	Part Number	Length [m]	Cable Type	Remarks
Drive – Power Connection	CSVP-P-001F	1	Normal Cable	Maximum Length: 2m
	CSVP-P-002F	2		
	CSVP-P-001M	1	Robot Cable	
	CSVP-P-002M	2		

⑤ EtherCAT Cable

Purpose	Part Number	Length [m]	Remarks
EtherCAT Connection	CGNR-EC-001F	1	<ul style="list-style-type: none"> STP(Shielded Twisted Pair) Cable Category 5e or higher Maximum Length: 100m Normal Cable
	CGNR-EC-002F	2	
	CGNR-EC-003F	3	
	CGNR-EC-005F	5	

* If you need cables with length(in units of 1m) not listed on the table or robot cables, please contact FASTECH for more information.

[Option] TB-Plus Interface Board

This is an interface board to connect Ezi-STEP II EtherCAT drive and I/O signals more conveniently.

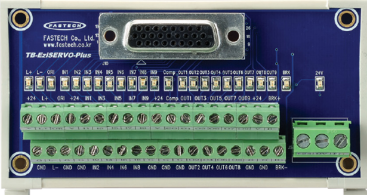
Purpose	Part Number	Product Image
Drive – I/O signal Connection Board	TB-Plus	

[Option] TB-Plus Interface Cable

These are the cables to connect Ezi-STEP II EtherCAT and TB-Plus interface board.

Purpose	Part Number	Length [m]	Cable Type	Remarks
Drive – Interface(TB-Plus) Connection	CIFN-S-001F	1	Normal Cable	Maximum Length: 20m
	CIFN-S-002F	2		
	CIFN-S-003F	3		
	CIFN-S-005F	5		
	CIFN-S-001M	1	Robot Cable	
	CIFN-S-002M	2		
	CIFN-S-003M	3		
	CIFN-S-005M	5		

* If you need cables with length(in units of 1m) not listed on the table, please contact FASTECH for more information.

External Wiring Diagram

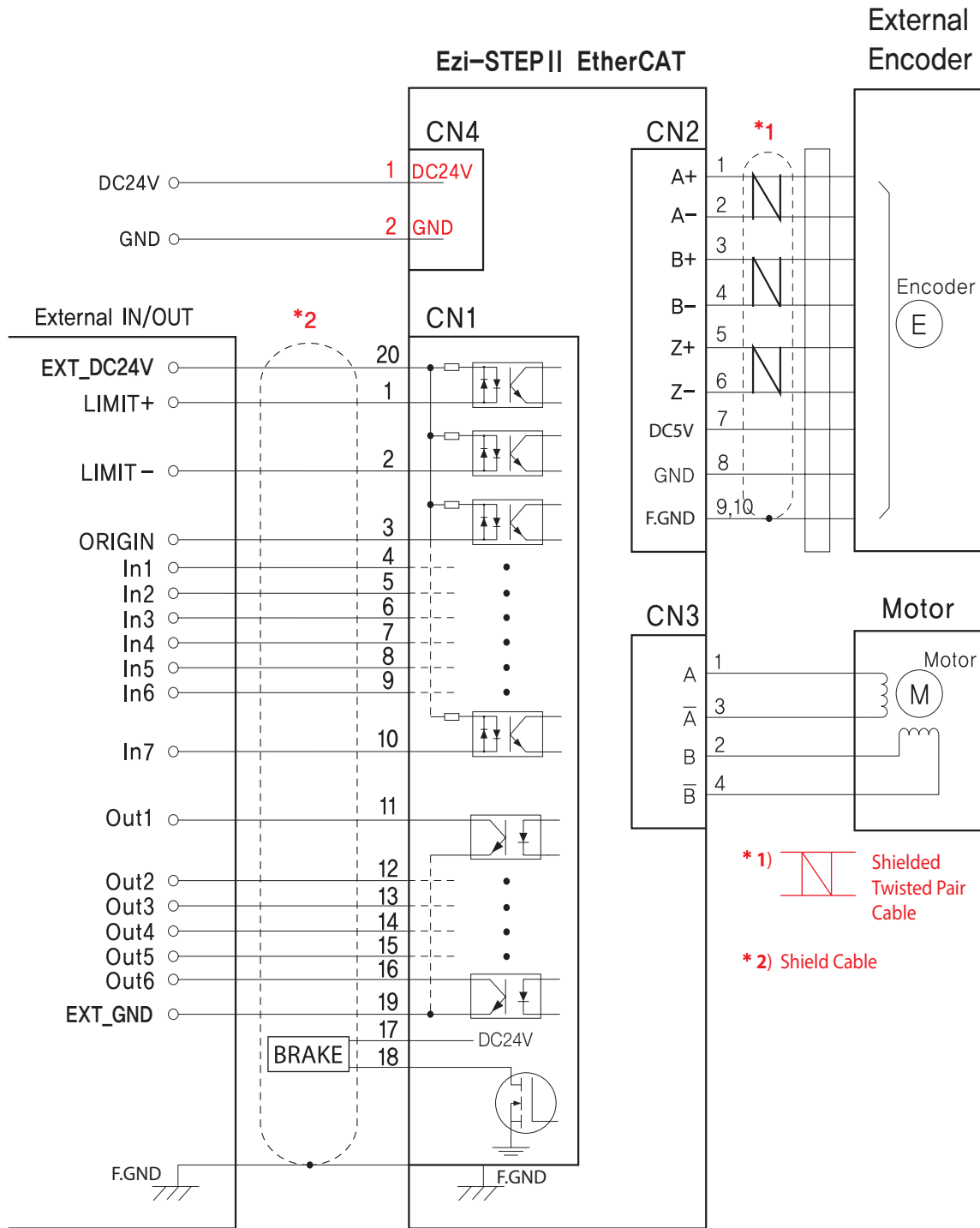

FASTECH Ezi-STEP II EtherCAT

CAUTION

In order to use the products listed in this catalog safely and correctly, be sure to read the instruction manual before using the product.

※ When connects I/O cable between controller and drive, please turn off the power of both controller and drive to prevent electric shock or to protect the drive from any damage.

● External Wiring Diagram [86mm Motor Drive]

FASTECH Ezi-STEP II EtherCAT

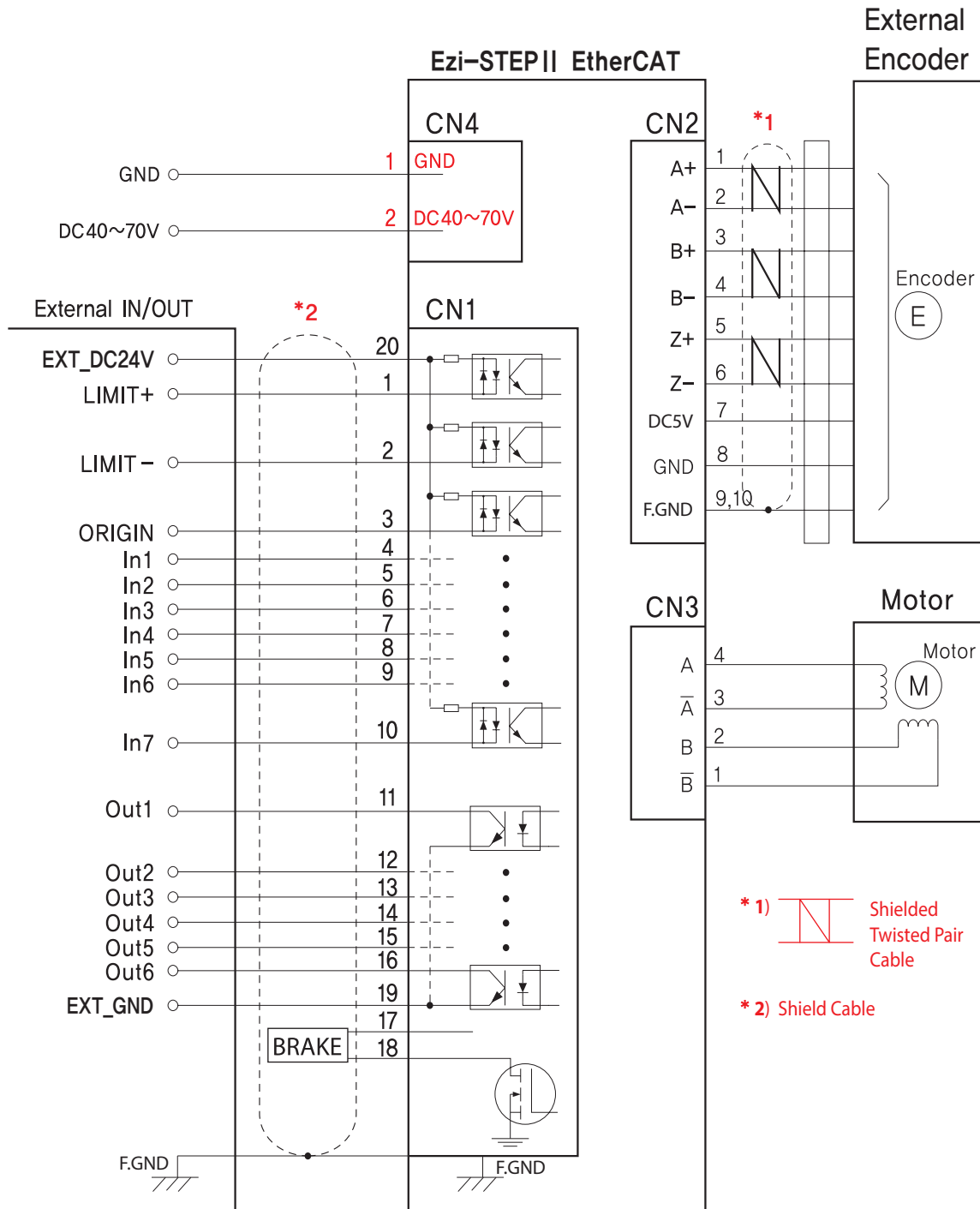

※ When connects I/O cable between controller and drive, please turn off the power of both controller and drive to prevent electric shock or to protect the drive from any damage.

CAUTION
 In order to use the products listed in this catalog safely and correctly, be sure to read the instruction manual before using the product.

MEMO



Fast, Accurate, Smooth Motion

FASTECH Co., Ltd.

Rm#1202, 401-dong, Bucheon Techno-Park,
655, Pyeongcheon-ro, Bucheon-si Gyeonggi-do,
Republic of Korea (Postal Code: 14502)
TEL : +82-32-234-6317 FAX : +82-32-234-6302
E-mail : sales@fastech-motions.com
Homepage : www.fastech-motions.com