

## AKD2G Part Number Scheme

Use the part number scheme for product identification only, not for the order process, because not all combinations of features are possible.

**NOTE**

Mating connectors are **not** included in the package of a standard drive.

Mating connectors are included when the drive is ordered with accessories (append “-A” to the model number).

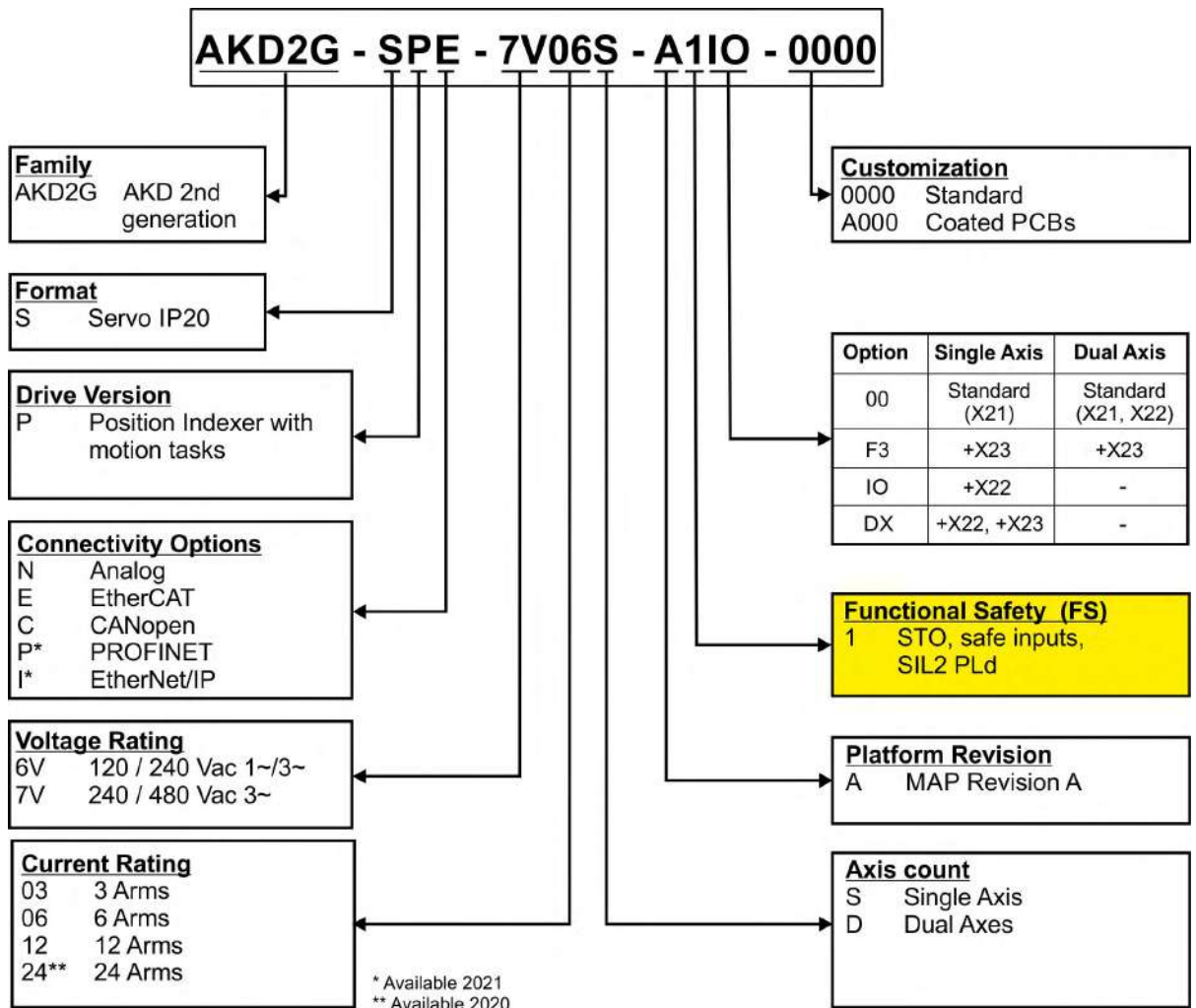

### Example AKD2G-SPE-7V06S-A1IO-0000

AKD2G IP20 housing, position indexer, EtherCAT, 240 V to 480 V mains supply, 6 A rated current, single axis, Platform Revision A, dual channel STO SIL2 PLd, with additional I/O connector X22, uncoated, no mating connectors.

### Example AKD2G-SPE-6V03D-A1DX-A000-A

AKD2G IP20 housing, position indexer, EtherCAT, 120 V to 240 V mains supply, 2 x 3 A rated current, dual axis, Platform Revision A, dual channel STO SIL2 PLd, with all possible connectors (X21 + X22 + X23), PCBs coated, with mating connectors.